

# GLADIATOR REAR INNER FENDER

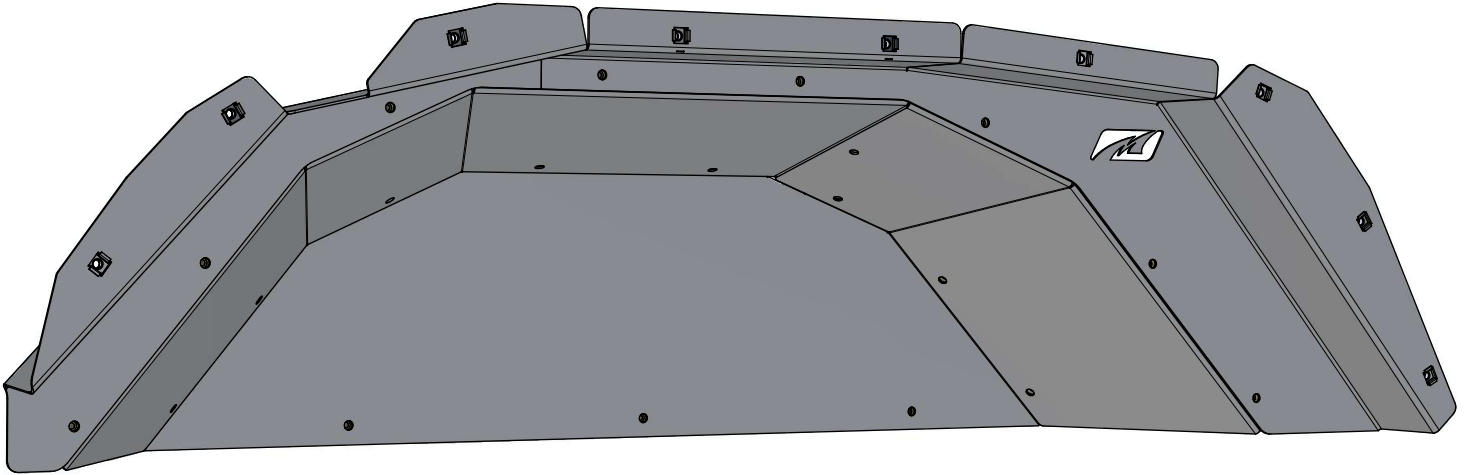

## ASSEMBLY INSTRUCTIONS

**MB1114 - Assembly Instructions Rear Inner Fender - JT**

**KIT COMPONENTS**

**MB1114-01**  
Qty: 1

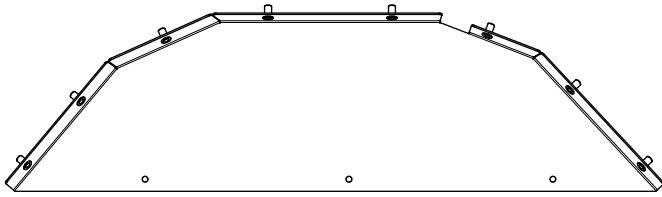

**MB1114-01\_MIR**  
Qty: 1

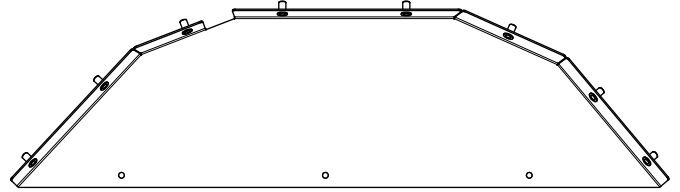

**MB1114-02**  
Qty: 1

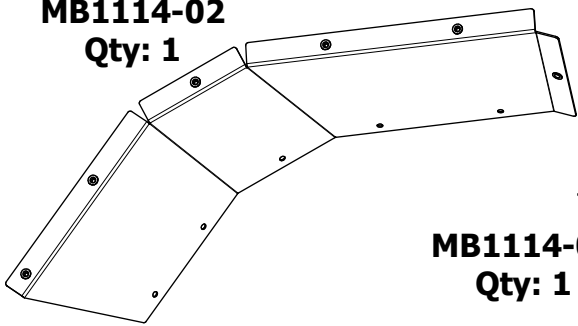

**MB1114-03\_MIR**  
Qty: 1

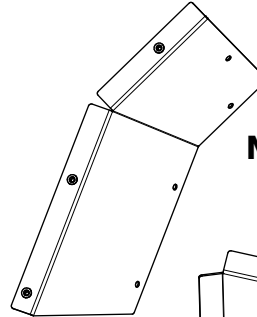

**MB1114-03**  
Qty: 1

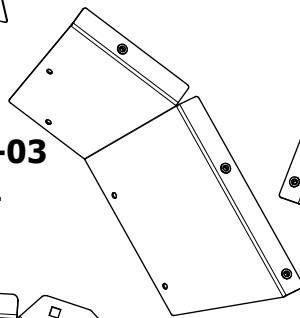

**MB1114-02\_MIR**  
Qty: 1

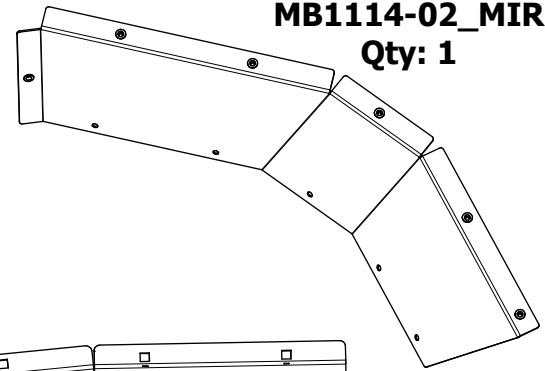

**MB1114-05**  
Qty: 1

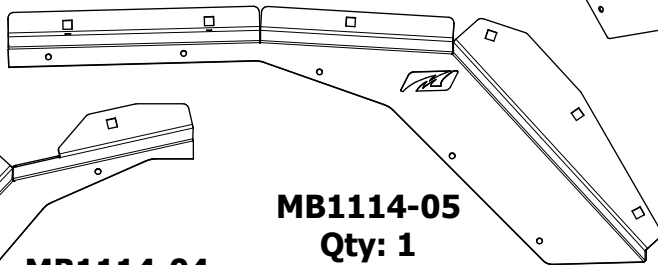

**MB1114-05\_MIR**  
Qty: 1

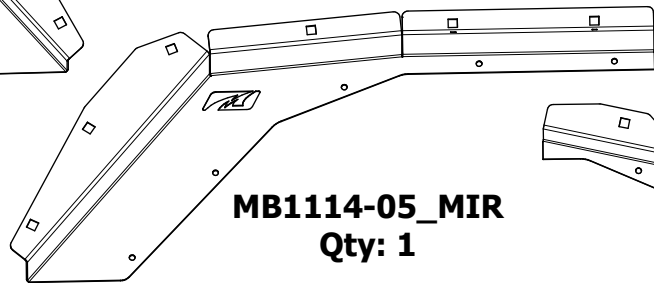

**MB1114-04**  
Qty: 1

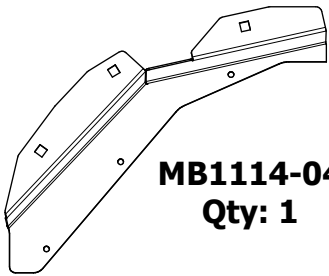

**MB1114-04\_MIR**  
Qty: 1

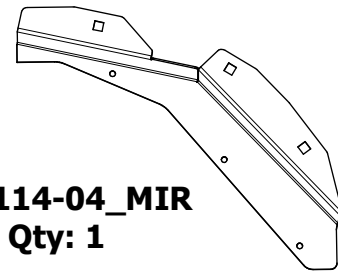

**MB1114-06**  
Qty: 1

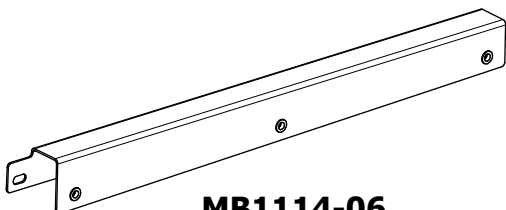

**MB1114-06\_MIR**  
Qty: 1

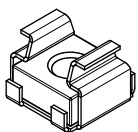
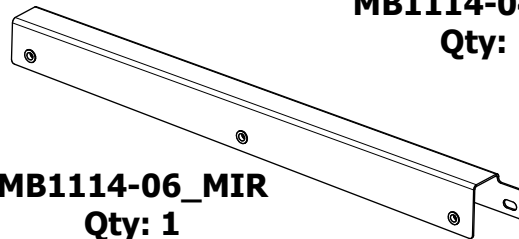

**CAGE NUT**  
1/4"-20  
Qty: 18

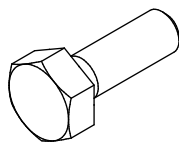

**HEX BOLT**  
1/4"-20 x 3/4"  
Qty: 22

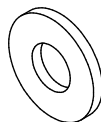

**FLAT WASHER**  
1/4"  
Qty: 8

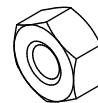

**NYLOCK NUT**  
1/4"-20  
Qty: 4

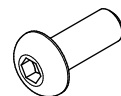

**BUTTON HEAD SCREW**  
#10-24 x 1/2"  
Qty: 40

**MB1114 - Assembly Instructions Rear Inner Fender - JT**

**DISASSEMBLY**

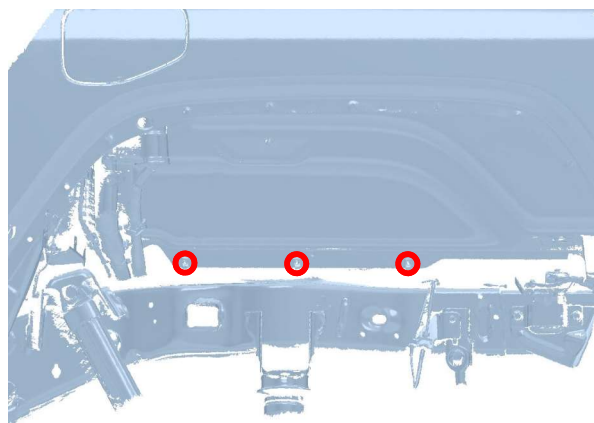

REMOVE FACTORY INNER FENDER FROM THE VEHICLE AND THEN REMOVE THE THREE BARREL NUTS FROM THE FENDER WELL.



USING A FLAT SCREWDRIVER, REMOVE THE THREE (3) FACTORY BARREL NUTS.

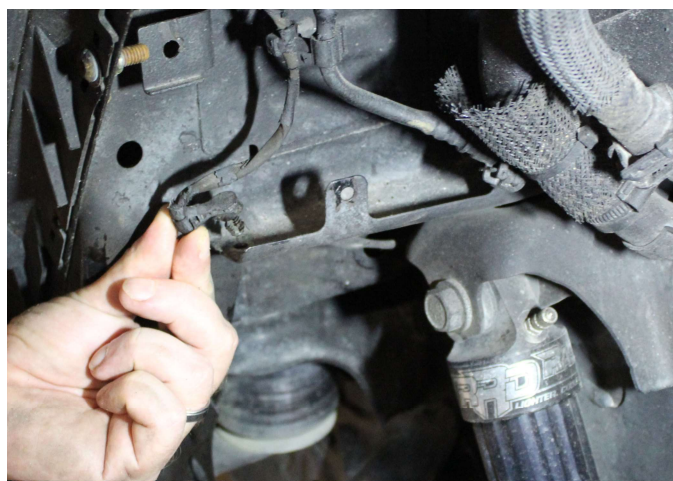

(FACTORY POSITION SHOWN)

ON THE DRIVERS SIDE ONLY, MOVE THE WIRING HARNESS TO THE RIGHT HOLE OF THE BRACKET.

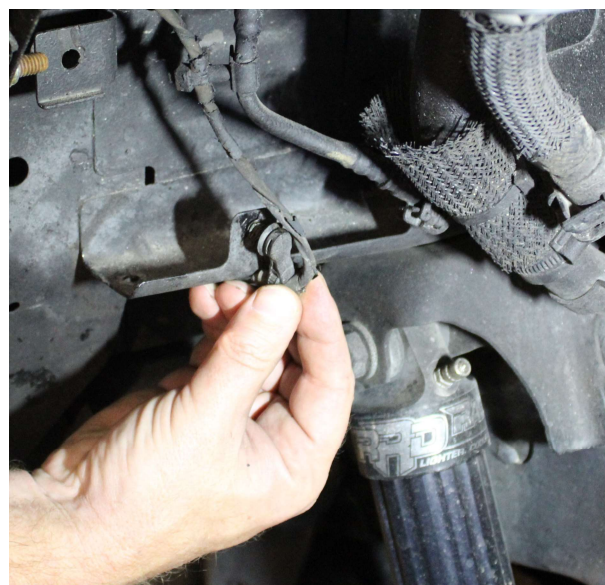

(RELOCATED POSITION SHOWN)

**MB1114 - Assembly Instructions Rear Inner Fender - JT****PREPARATION**

ON BOTH THE DRIVER AND PASSENGER SIDE, CUT AND REMOVE THIS SECTION OF THE BRACKET TO ALLOW FOR ENOUGH CLEARANCE FOR THE INNER FENDER. PAINT ANY EXPOSED METAL TO PREVENT CORROSION.



CUT LINE

REMOVE THIS SECTION

**MB1114 - Assembly Instructions Rear Inner Fender - JT**

**INSTALLATION**

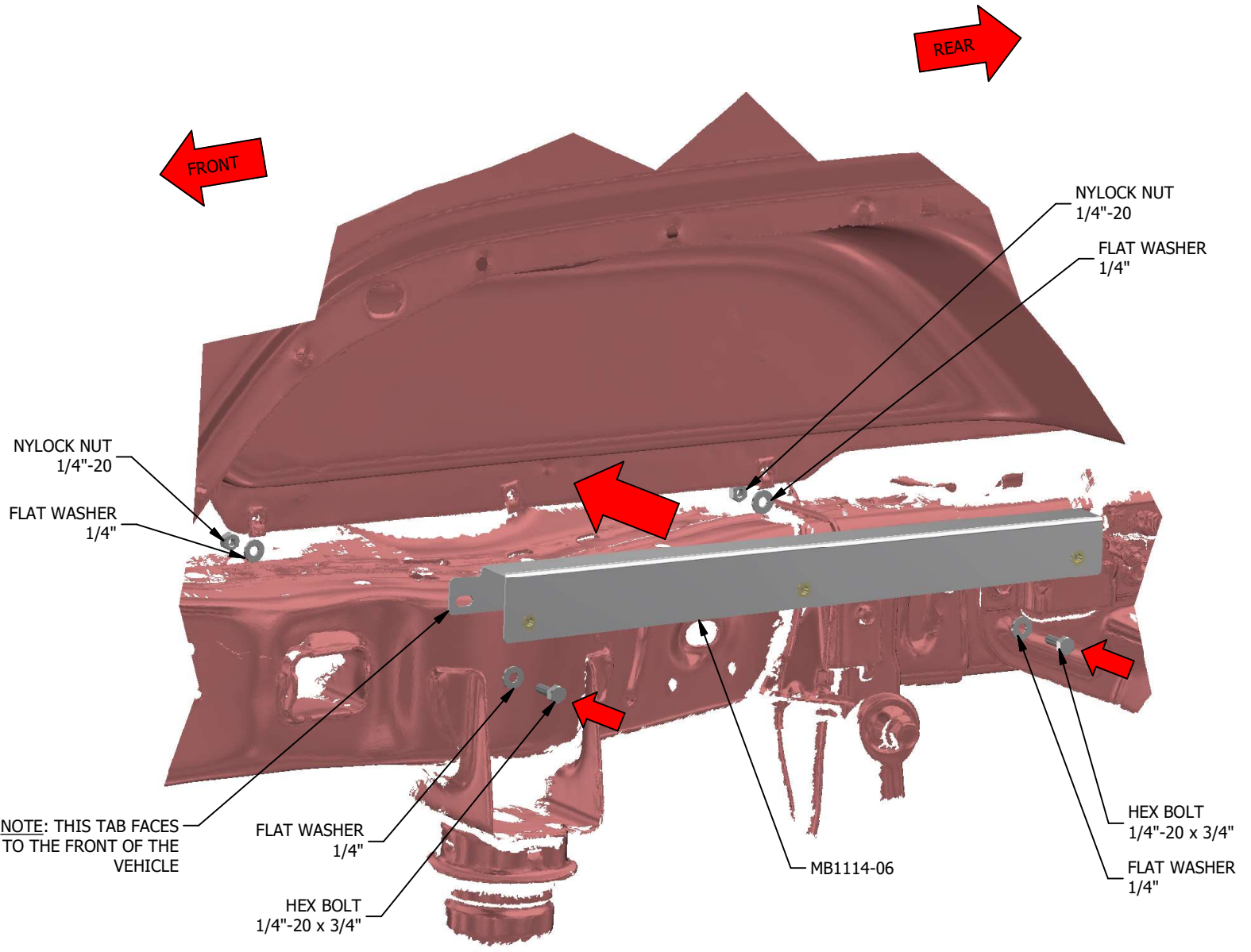

DRIVERS SIDE SHOWN

**MB1114 - Assembly Instructions Rear Inner Fender - JT**

**INSTALLATION**

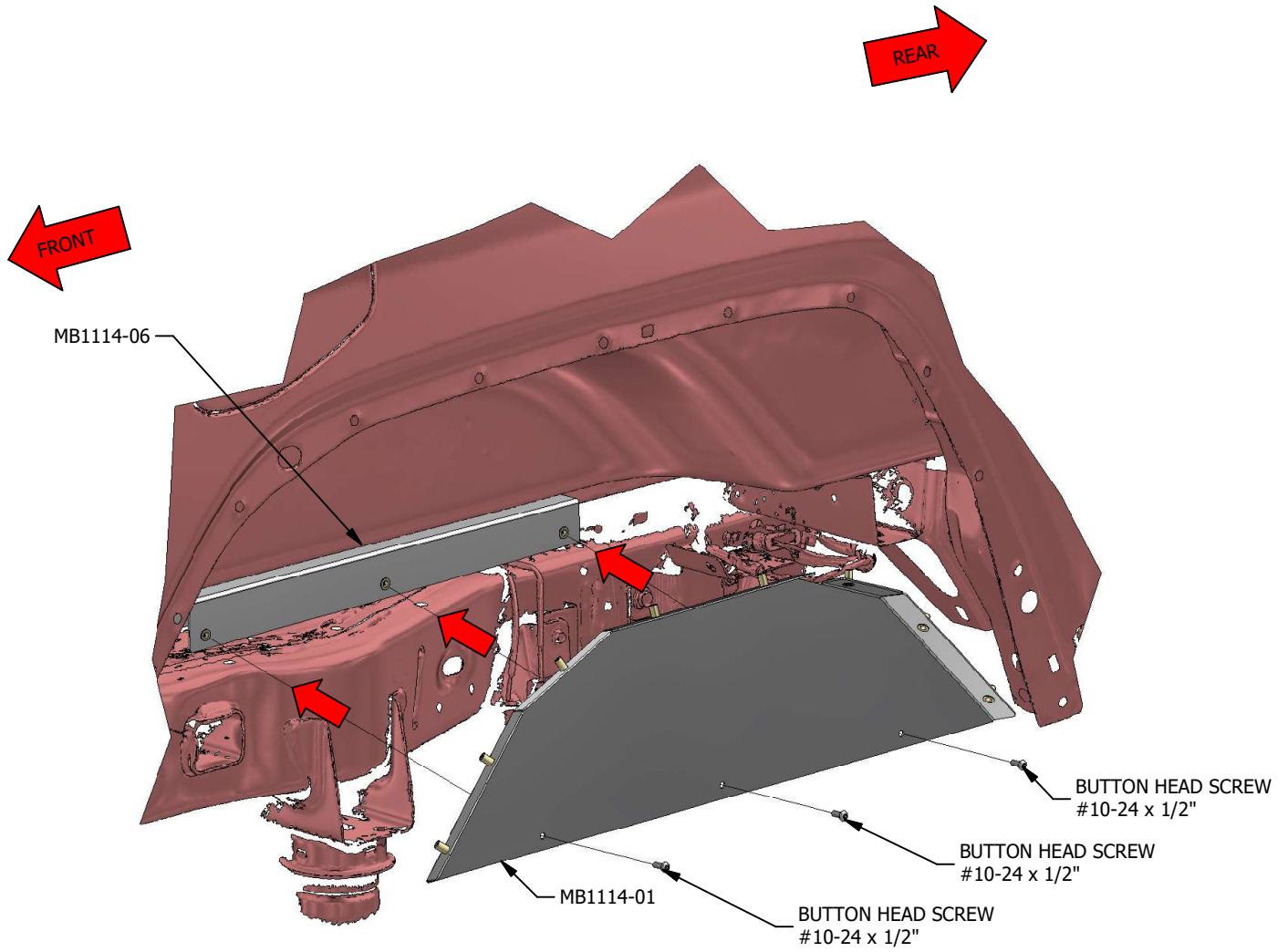

DRIVERS SIDE SHOWN

**MB1114 - Assembly Instructions Rear Inner Fender - JT**

**INSTALLATION**

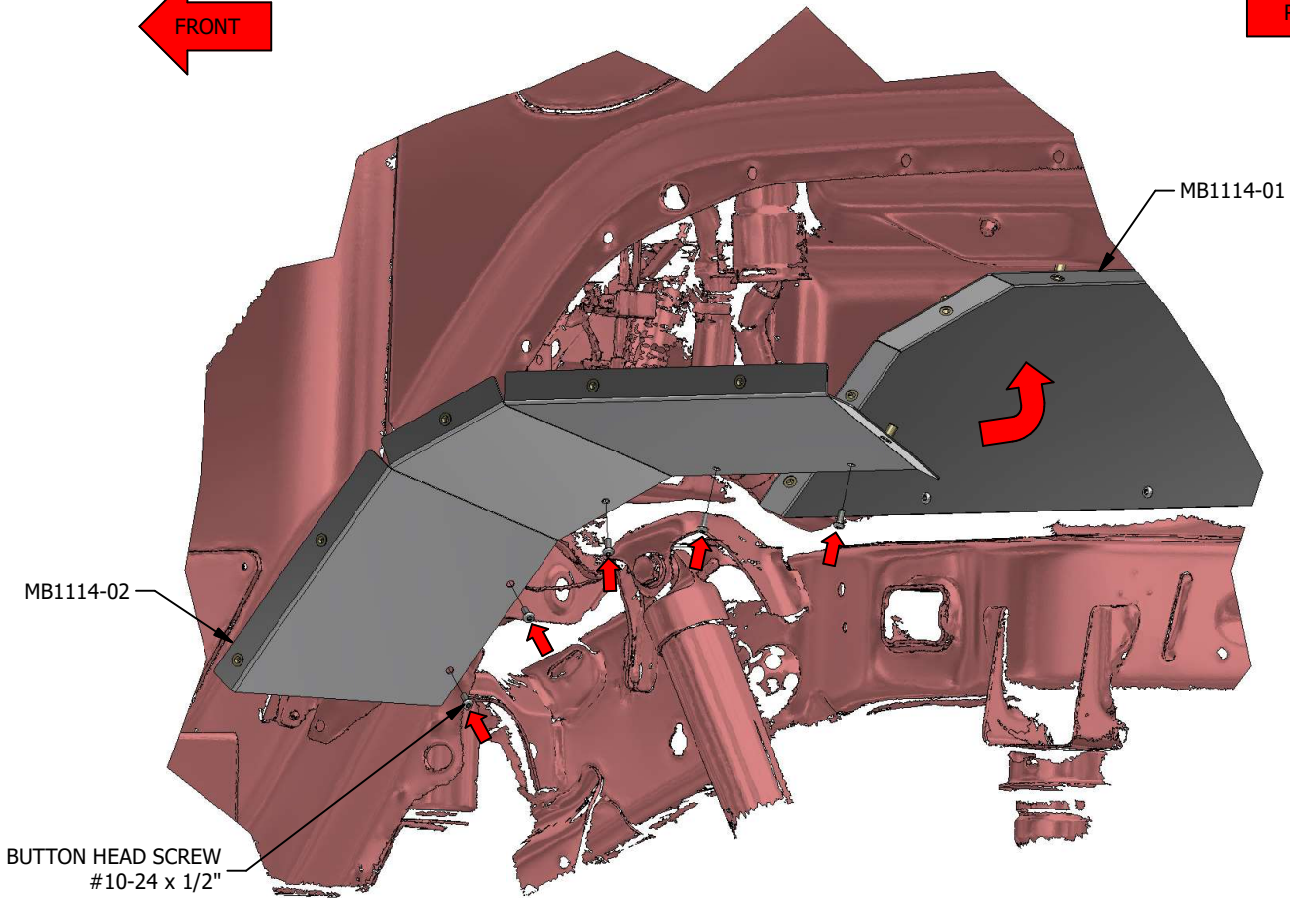
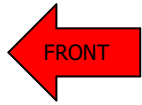

DRIVER SIDE SHOWN

**ASSEMBLED**

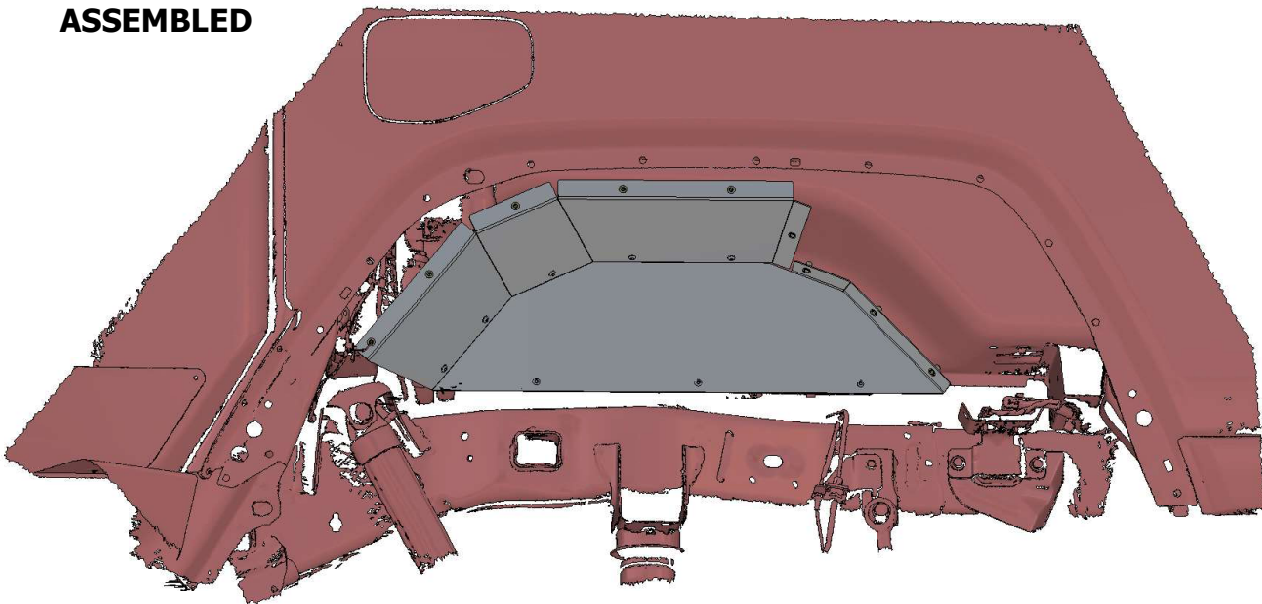

**MB1114 - Assembly Instructions Rear Inner Fender - JT**

**INSTALLATION**

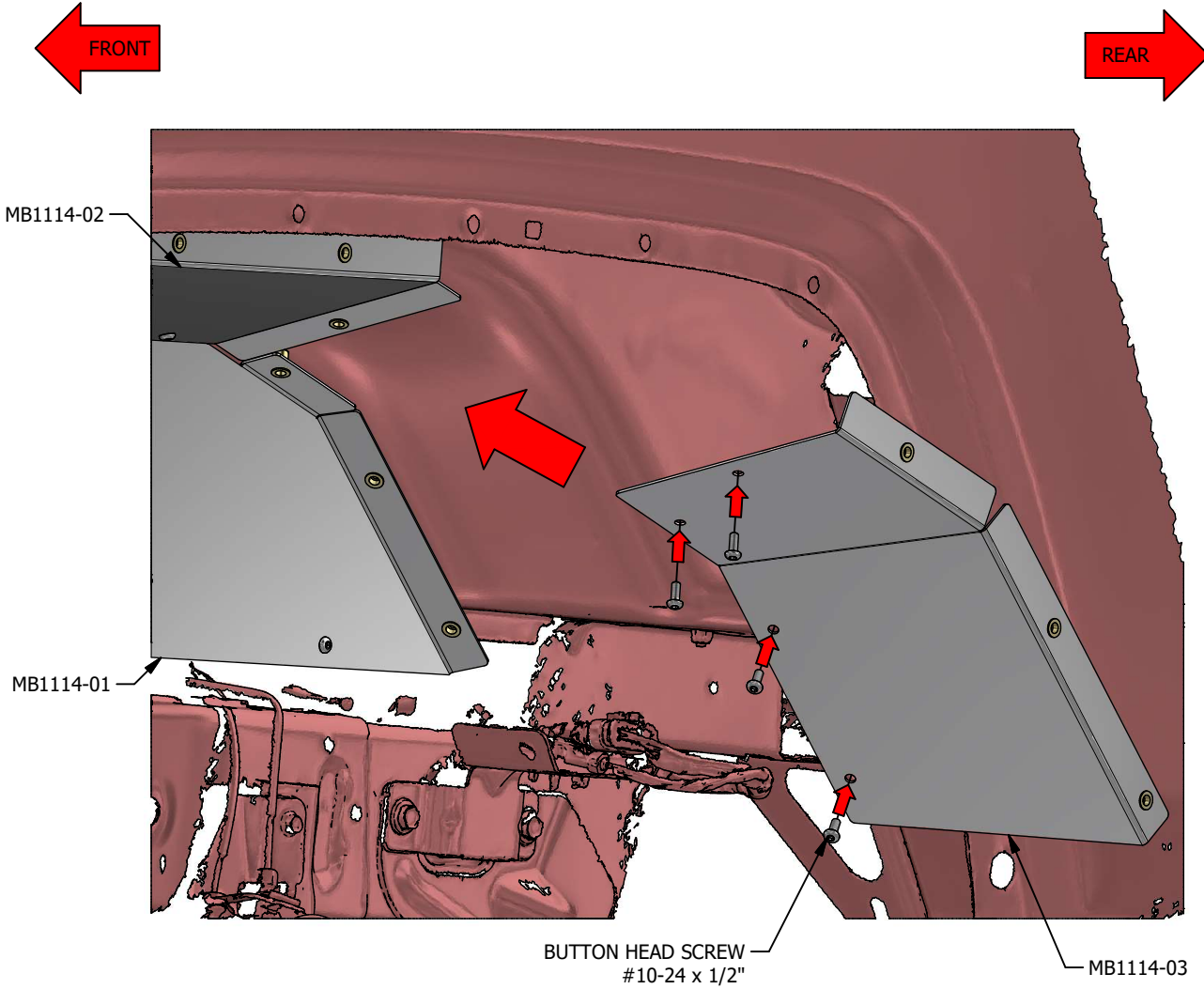

**ASSEMBLED**

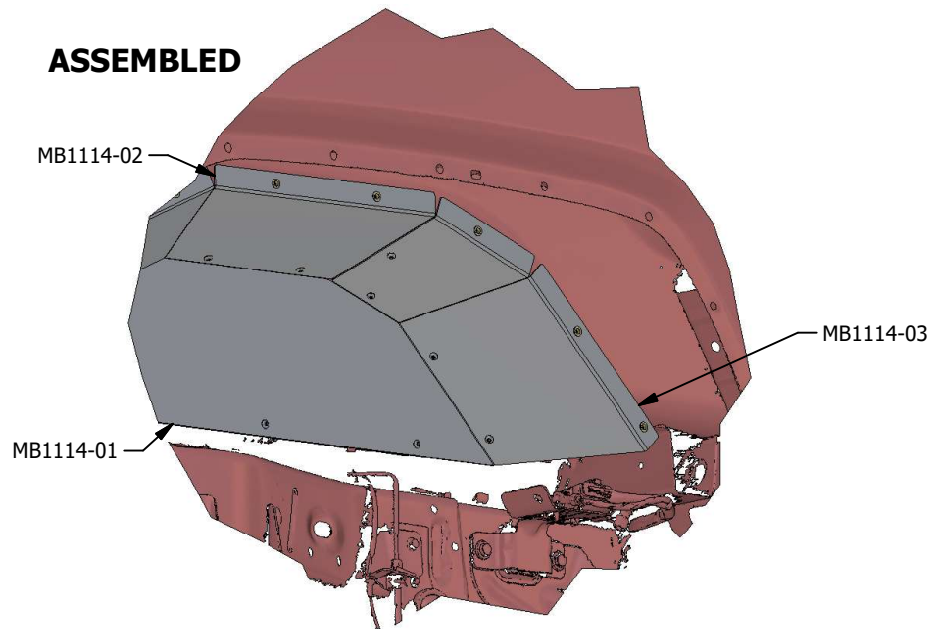



**MB1114 - Assembly Instructions Rear Inner Fender - JT**

**INSTALLATION**

NOTE: CAGE NUTS NEED TO BE INSTALLED ON THE BACK SIDE OF ALL FLANGES

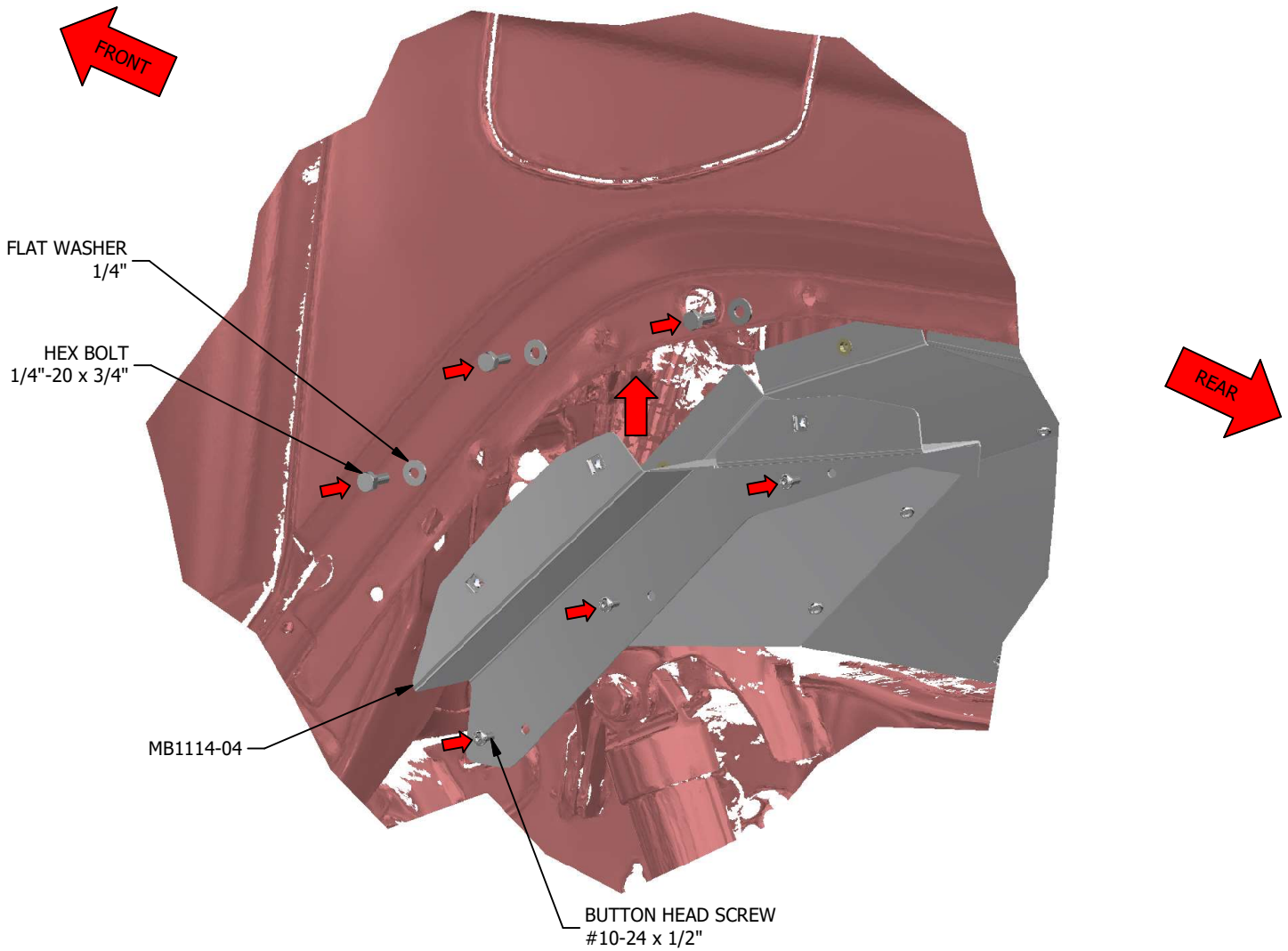
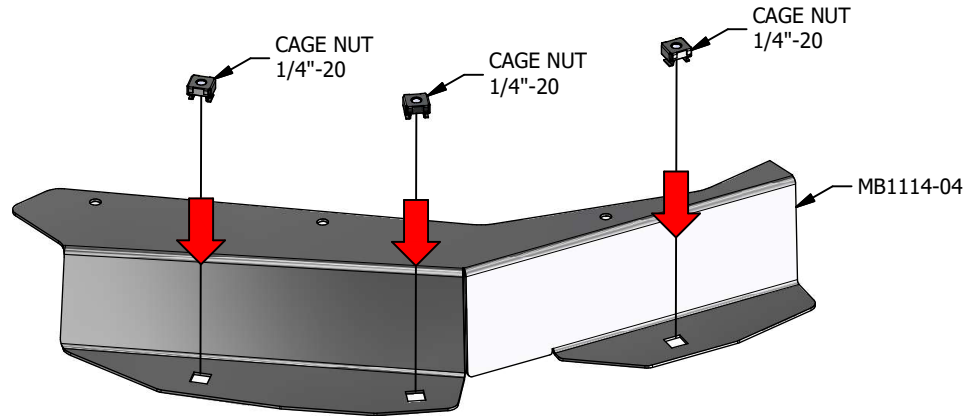

DRIVERS SIDE SHOWN

**MB1114 - Assembly Instructions Rear Inner Fender - JT**

**INSTALLATION**

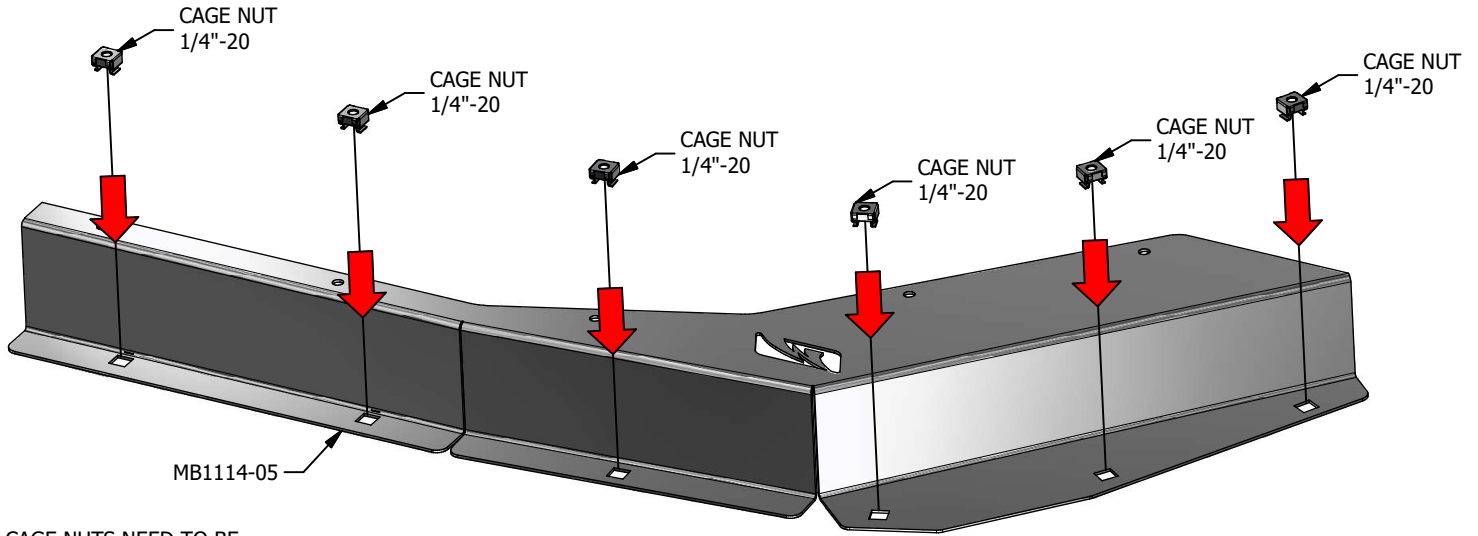

**NOTE:** CAGE NUTS NEED TO BE INSTALLED ON THE BACK SIDE OF ALL FLANGES

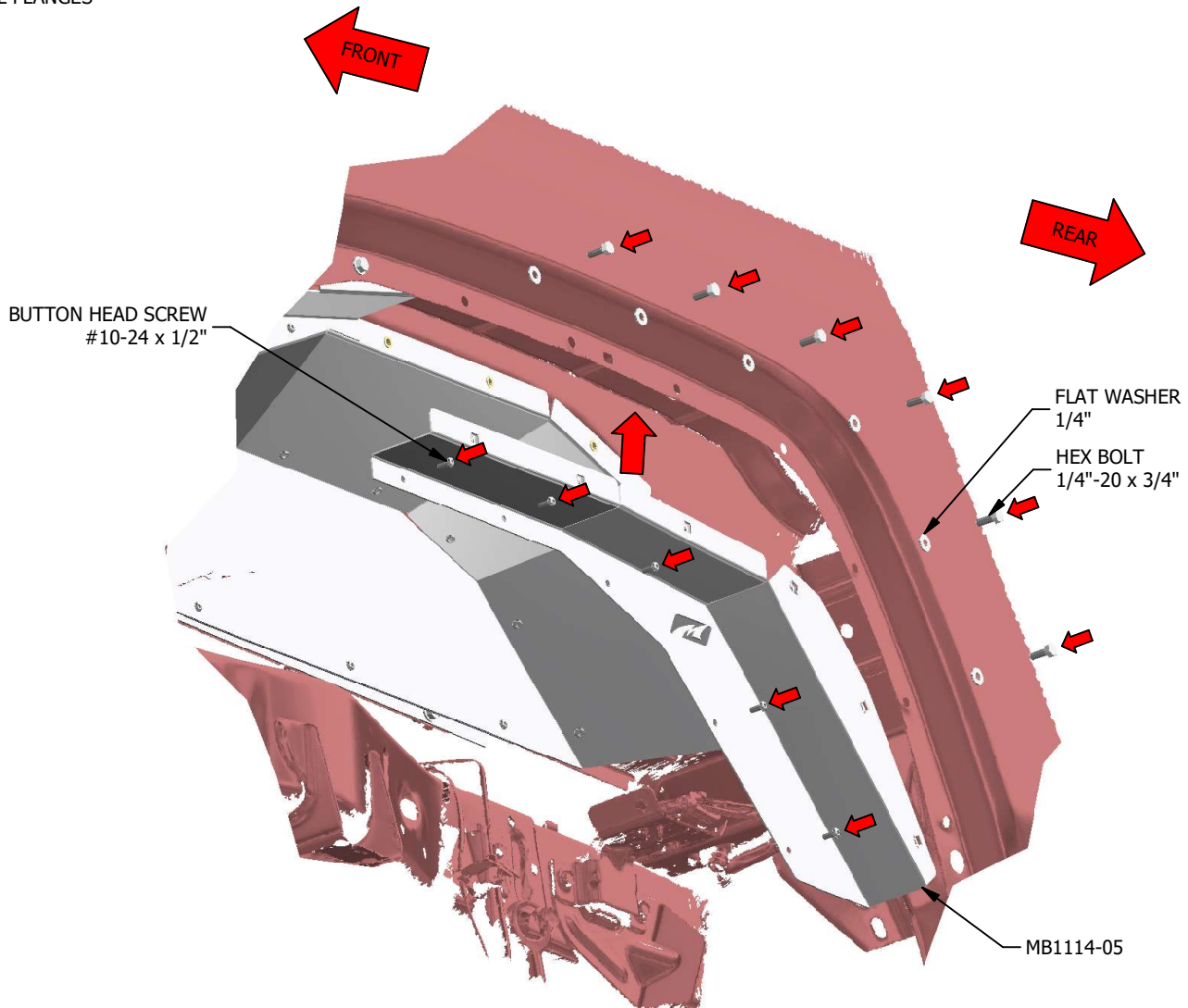

REPEAT INSTALLATION ON PASSENGER SIDE USING PARTS LABELED AS "\_MIR"