

PARTS LIST			
ITEM	QTY	PART NUMBER	DESCRIPTION
1	1	MB1106-A	Transmission Skid
2	9		FHSCS 3/8 x 1" Stainless

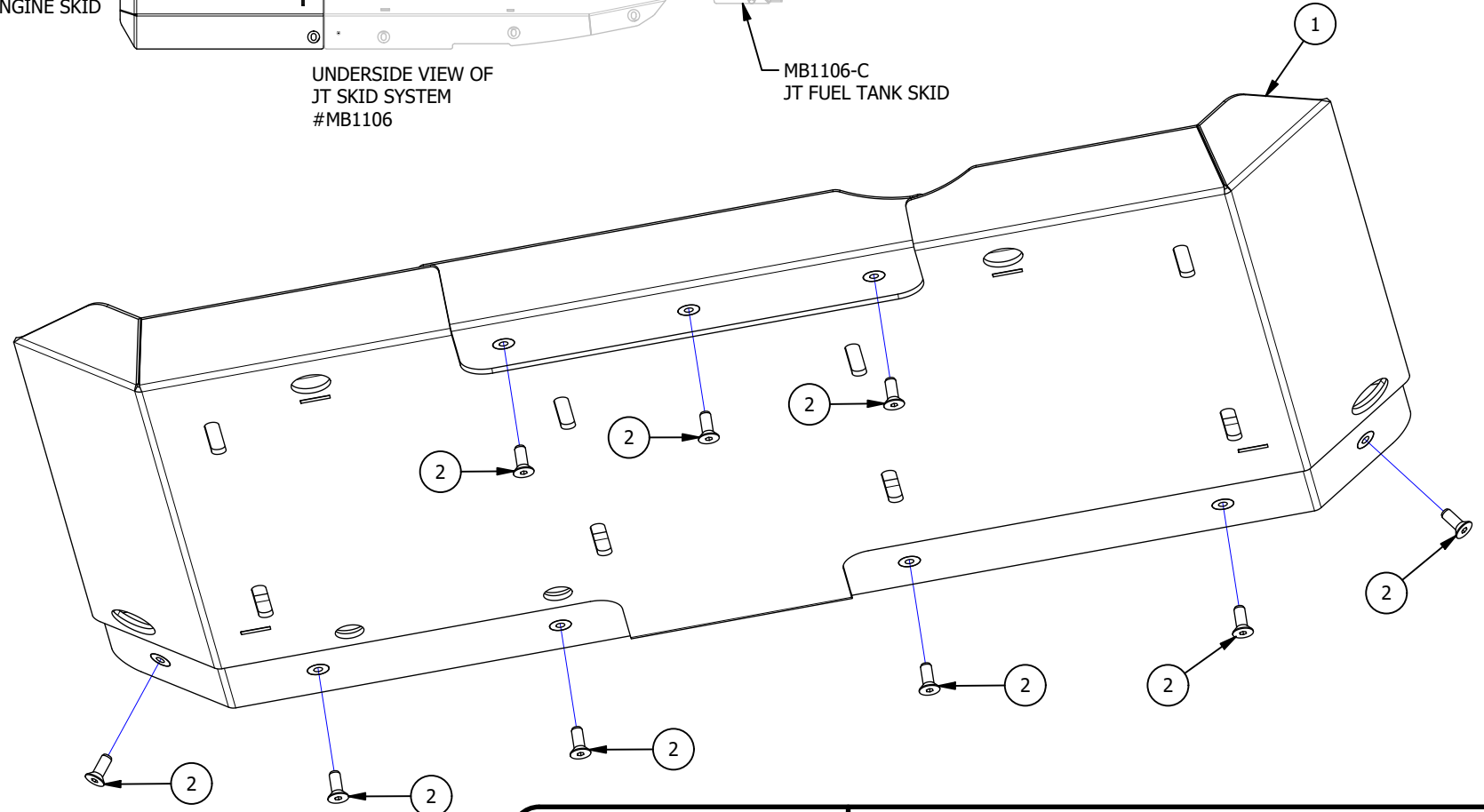

Dwg/Part No:
MB1106-A

Description:
Jeep JT Transmission Skid

Mat'l:

Sheet No: **1** of **4**
Rev No: **0**

PARTS LIST

ITEM	QTY	PART NUMBER	DESCRIPTION
1	1	MB1106-B-01	Plate B-01
2	1	MB1106-B-01	Plate B-01 Oil Pan Access
3	1	MB1106-B-03	Plate B-03
4	1	MB1106-B-04	Plate B-04
5	1	MB1106-B-05	Plate B-05
6	1	MB1106-B-06	Plate B-06
7	1	MB1106-B-07	Plate B-07
8	1	MB1106-B-08	Plate B-08
9	4		Flat Washer 3/8"
10	4		Nylock Hex Nut 3/8" GR 8 Zinc
11	4		Hex Bolt 3/8 x 1" GR 8 Zinc
12	4		FHSCS 3/8 x 1" Stainless
13	4		Nylock Hex Nut M10 GR 8 Zinc

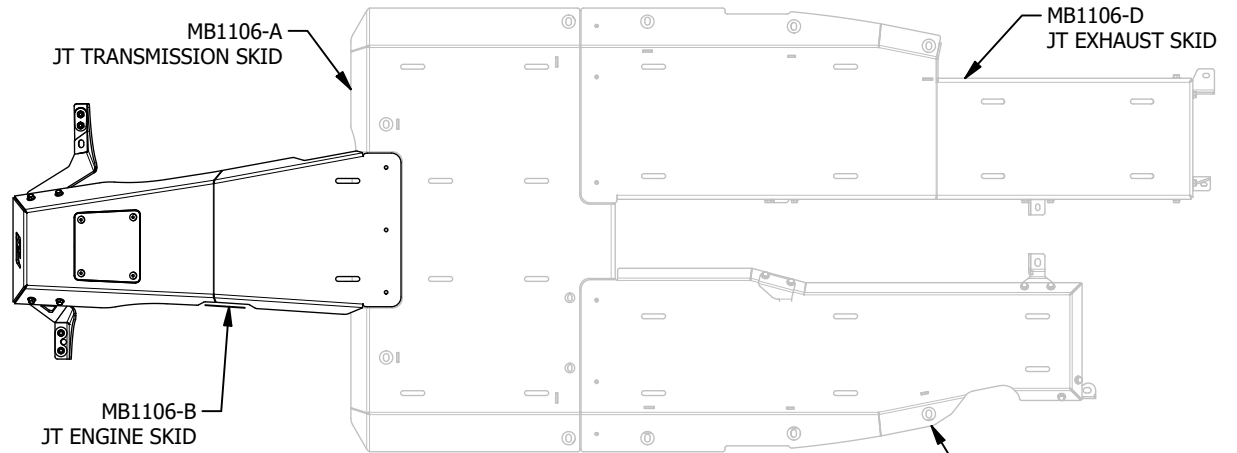
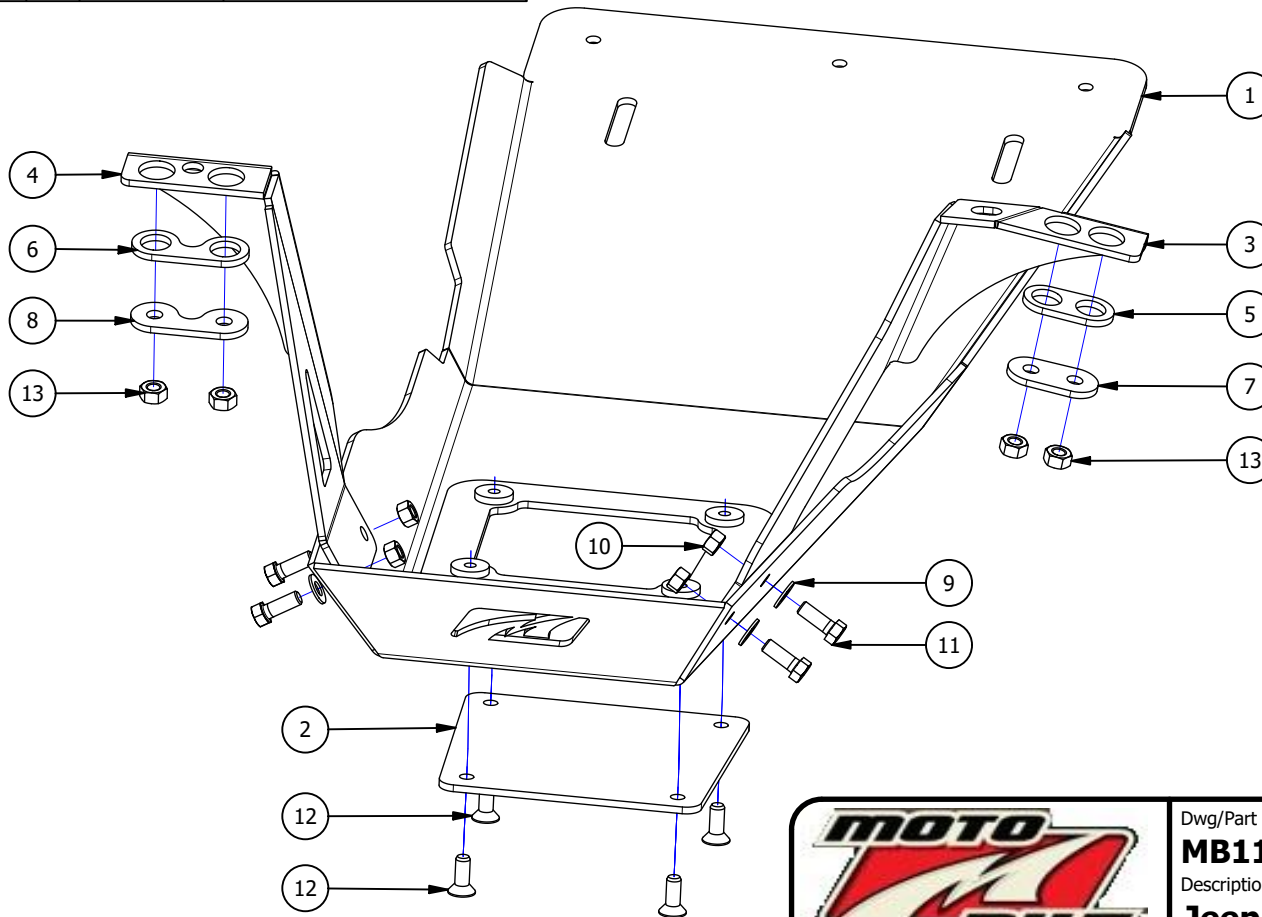

 UNDERSIDE VIEW OF
 JT SKID SYSTEM
 #MB1106

 Dwg/Part No:
MB1106
 Description:
Jeep JT Engine Skid

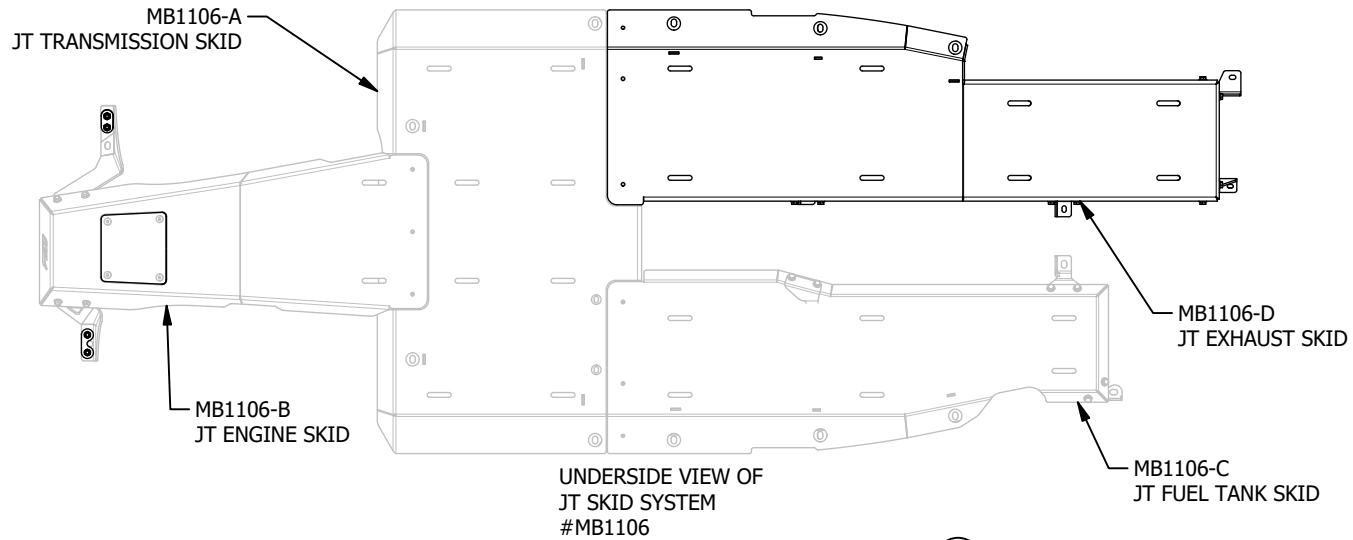
Mat'l:

 Sheet No: **2** of **4**
 Rev No:

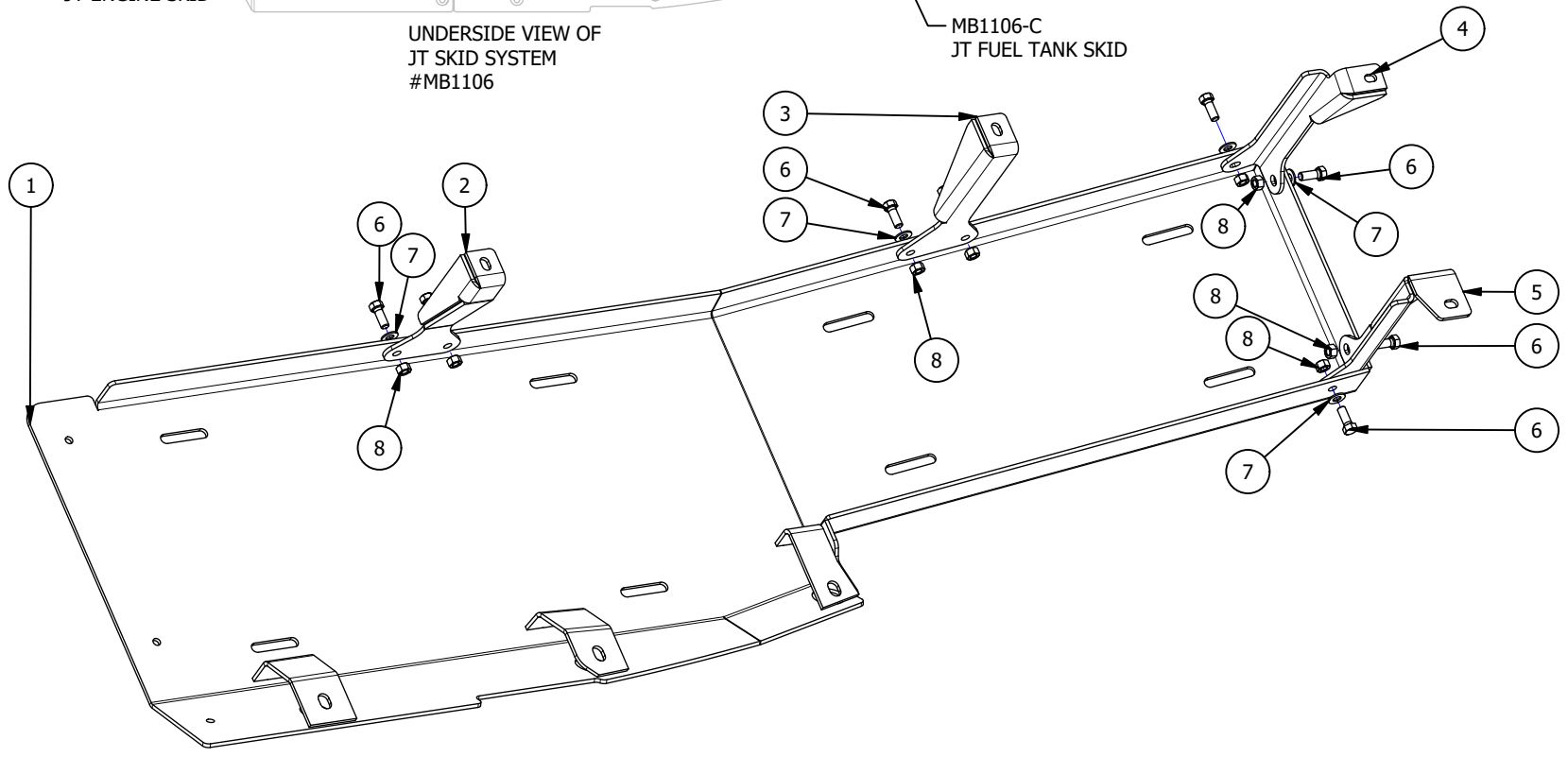

PARTS LIST			
ITEM	QTY	PART NUMBER	DESCRIPTION
1	1	MB1106-C-01	Plate C-01
2	1	MB1106-C-05	Plate C-05
3	1	MB1106-C-06	Plate C-06
4	1	MB1106-C-07	Plate C-07
5	1	MB1106-C-08	Plate C-08
6	8		Hex Bolt 3/8 x 1 GR 8 Zinc
7	8		Flat Washer 3/8"
8	8		Nylock Hex Nut 3/8" GR 8 Zinc



Dwg/Part No:
MB1106-C
 Description:
Jeep JT Exhaust Skid

Sheet No: **3** of **4**
 Rev No: **0**
 Mat'l:

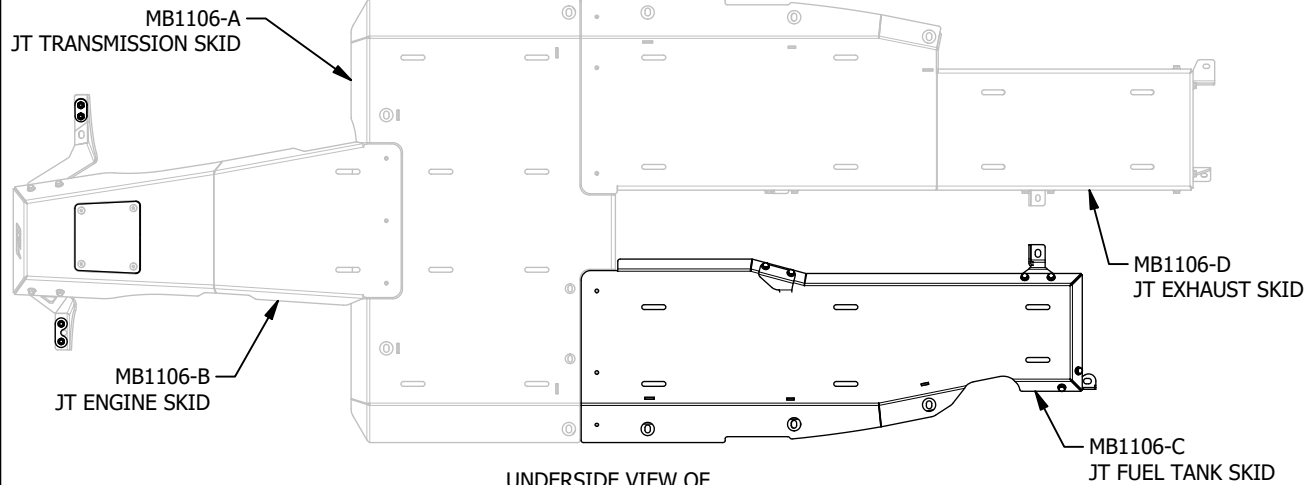
 UNDERSIDE VIEW OF
 JT SKID SYSTEM
 #MB1106

PARTS LIST			
ITEM	QTY	PART NUMBER	DESCRIPTION
1	1	MB1106-D-01	Plate D-01
2	1	MB1106-D-06	Plate D-06
3	1	MB1106-D-05	Plate D-05
4	1	MB1106-D-07	Plate D-07
5	6		Hex Bolt 3/8 x 1" GR 8 Zinc
6	6		Flat Washer 3/8"
7	6		Nylock Hex Nut 3/8" GR 8 Zinc

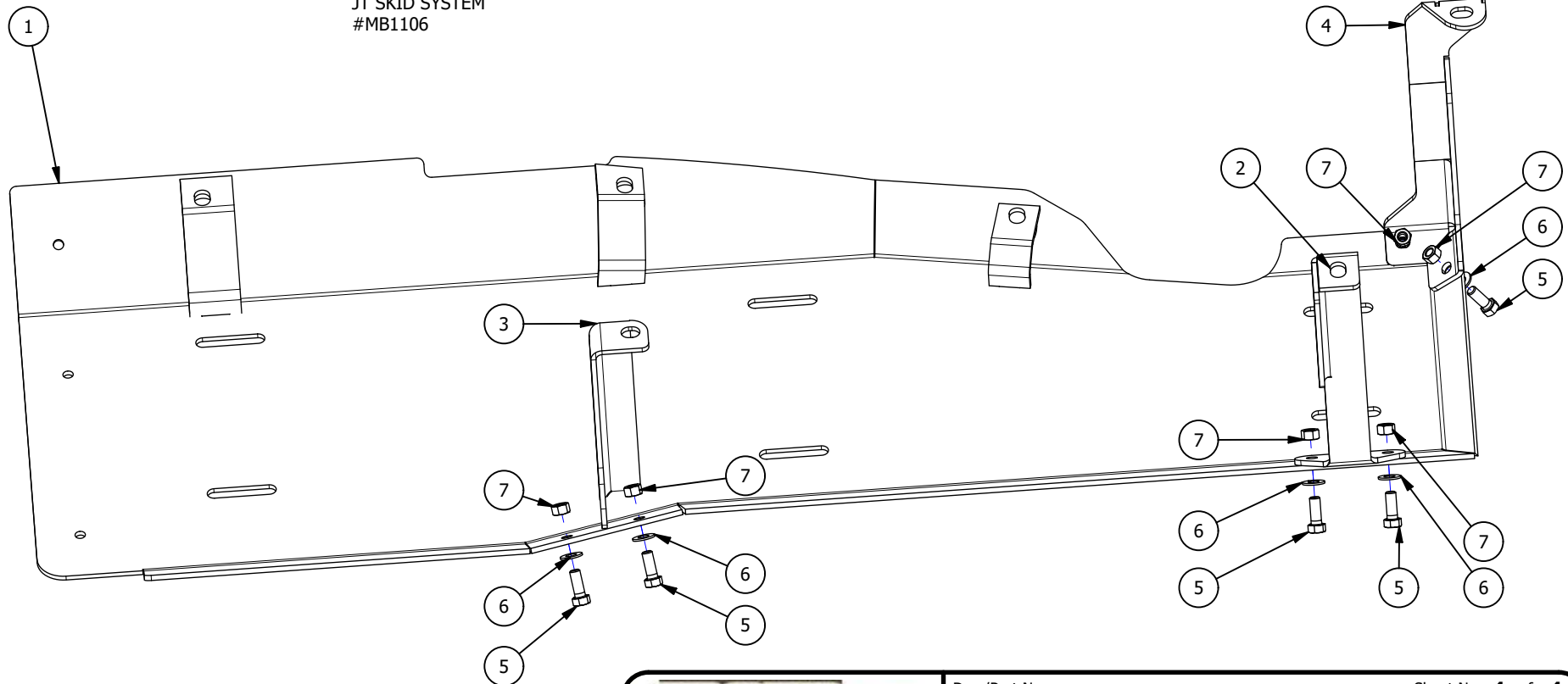

Dwg/Part No:

MB1106-D

Description:

Jeep JT Fuel Tank Skid

Mat'l:

 Sheet No: **4** of **4**

 Rev No: **0**

WELD NUT INSTALLATION FOR CERTAIN JT GLADIATOR MODELS

REAR OF JT GLADIATOR

NOTE

NOTE: Jeep JT Gladiator frames are built at the factory to a variety of different configurations to accept optional equipment. We have circled five (5) different areas in the diagram. Rubicon models are shipped with threaded holes at all five (5) locations. Other models may or may not have threaded holes at the up to four (4) of the circled locations, depending on how the frame was constructed at the factory. We have included four (4) threaded weld nuts with this kit.

Please verify your vehicle model & if appropriate, weld on the threaded weld nuts if any of the threaded fasteners are not present on your vehicle model. Drill a 3/4" diameter hole using a step drill. Our weld nuts are positioned using this 3/4" hole then welded permanently in place. Continue with installation.

FRONT OF JT GLADIATOR

WELD NUT INSTALLATION FOR CERTAIN JT GLADIATOR MODELS**NOTE:**

You will be drilling into the frame of your Gladiator. The following images show you how to install the weld nuts in general, **but you will need to follow the written instructions that accompany the images to correctly modify your vehicle.**

1

Using the skid plate as a template, mark the center of the hole. Remove the skid plate then drill a $\frac{3}{4}$ " hole in the frame or cross member.

If there is a unthreaded hole or slot in the frame already, drill a $\frac{3}{4}$ " hole in the frame or cross member to allow the weld nut to fit

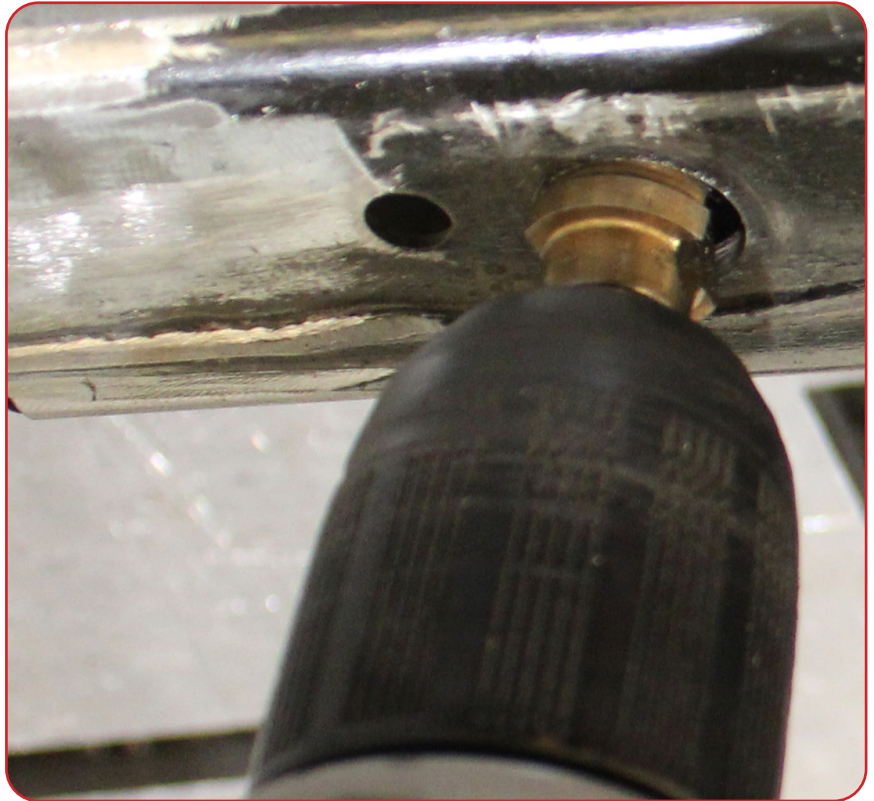
**2**

Smooth out the surface around the hole so that the weld nut flange will sit flush.

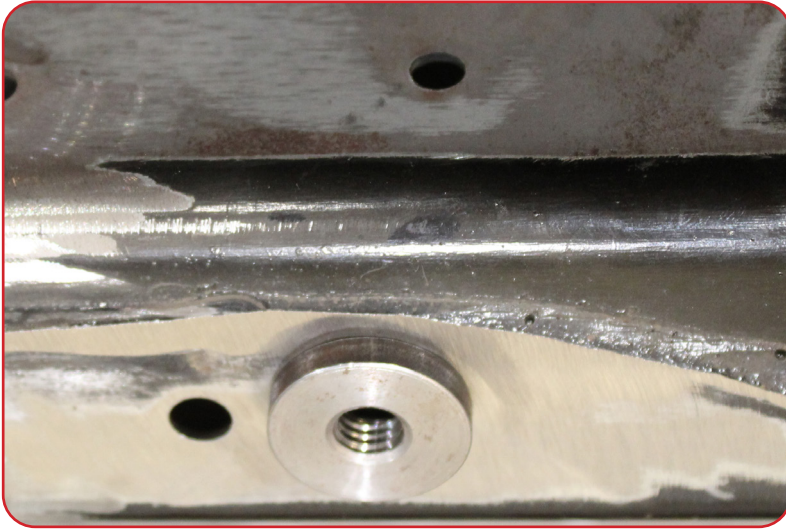
WELD NUT INSTALLATION FOR CERTAIN JT GLADIATOR MODELS**3**

Insert the weld nut so that the flange is facing out and tack the weld nut in place.

4

Reinstall the skid to confirm alignment and the skid plate will bolt back into place.

5

Remove the skid plate and fully weld the weld nut to the frame.

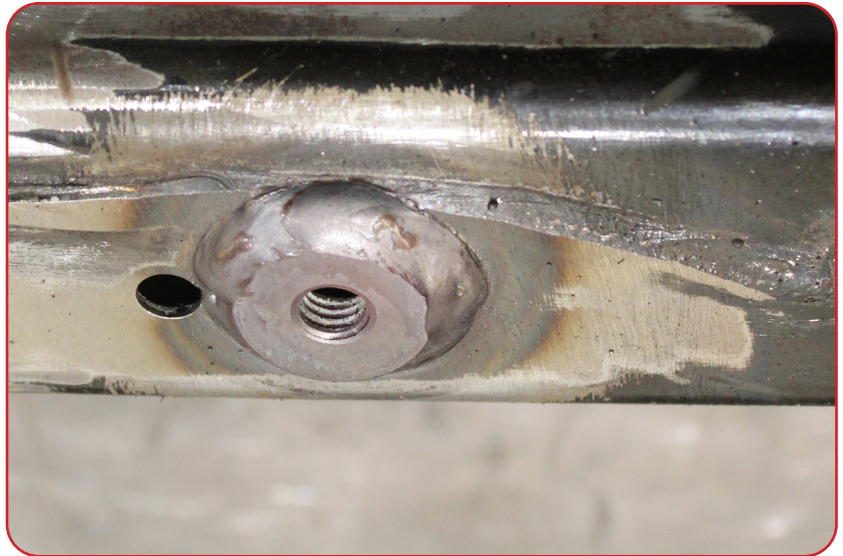
**6**

Paint the welded area to prevent corrosion.

7

Bolt the skid plate back into place.