

# FAMISKY

standing desk



---

Assembly Instruction  
for use with

FAMISKY Desktops 48" and larger

For Assembly assistance, email [service@famisky-us.com](mailto:service@famisky-us.com)

---

## Caution



Keep children and pets away from the electric height-adjustable desk during the operation. Unplug the power cord during a thunderstorm or if you do not intend to use the desk for a long time.



Make sure desktop not touching the wall.



Ensure no obstacles in the desk's path and no object above and 20" under the desk.



Working environment temperature 0-40°C, keep products away from corrosive gas, liquid and dusty objects.



It is strictly forbidden to disassemble the products privately to avoid that the failure of the products or the damage to the human body caused by electronic products, etc.



Although the product with anti-collision function, in order to avoid any pinching, please ensures that hands or other parts of your body are in a safe position during the operation. Anti-collision is not enabled during all resets.



Please read the following instructions carefully before start using the high-adjustable desk. The company does not bear any warranty or liability for damage and human injury caused by any abnormal operation.



It is necessary to reset manually after the initial installation or power off.

# Parts List

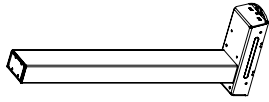

A-Column×2

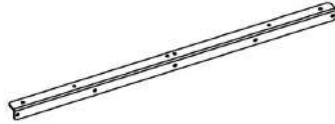

B-Long beam×1

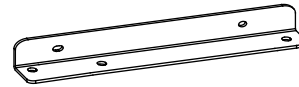

C-Short beam×2



D-Shrut×2

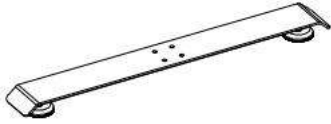

E-Foot×2



F-Connection board×n

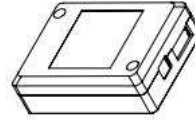

G-Control box×1



H-Handset×1

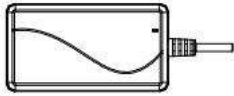

I-Adapter×1



J-M5 Allen Key×1

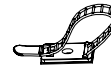

K-Cable clip×5

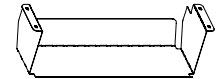

L-Bracket×1



M-Wooden pin×n



N-Hook×2



O-M6×15 screw×20

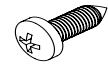

P-ST4×12 screw×7



Q-ST4.8×15 screw×n



R-M4.8×19 screw×2



S-M6×12 screw×2

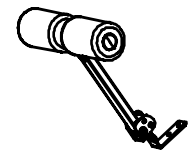

T-Foot supporting×1

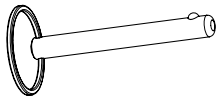

U-Ø6×58 Melt×1

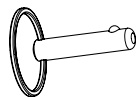

V-Ø8×26 Melt×1

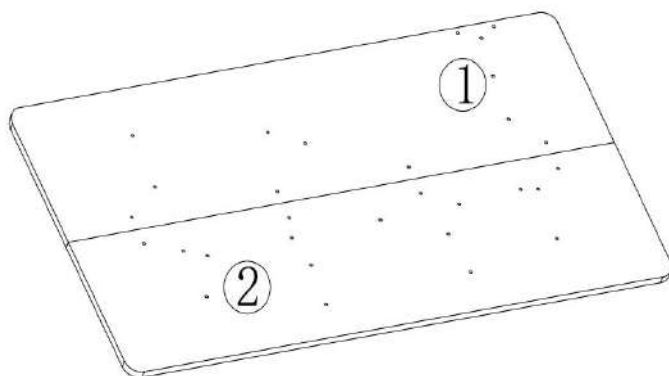

W-Table board 1/2

## Tools Needed (Not Included)

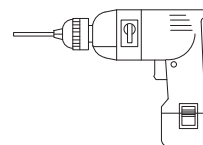

Electric Drill

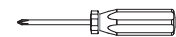

Phillips Screwdriver

# Assembly

## Step 1

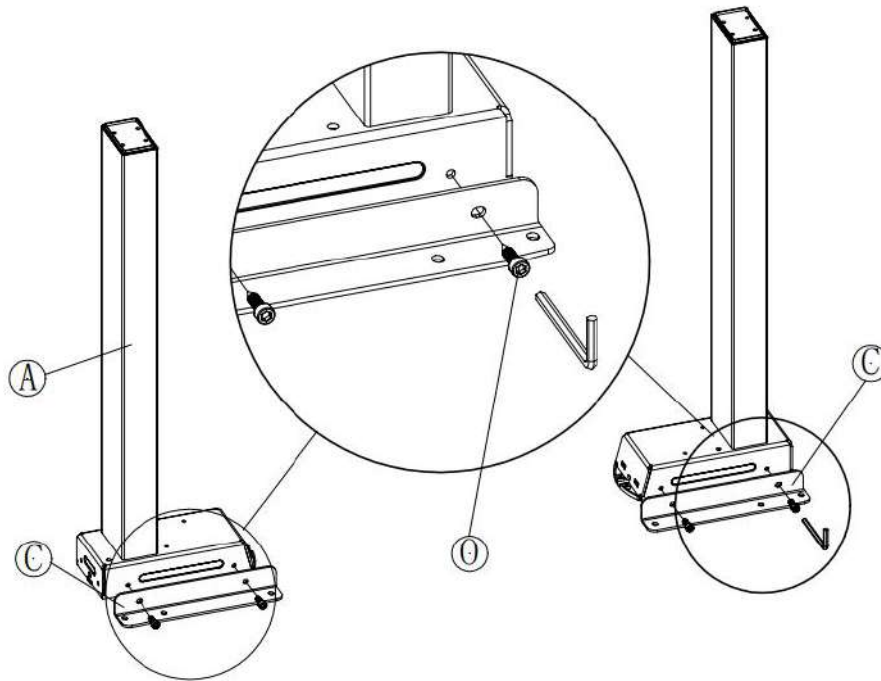

### Checklist

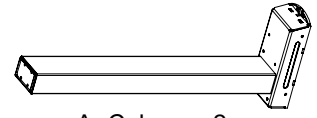

A- Column x2



C- Short beam x2



O - M6x15 Screw x4



M5

## Step 2

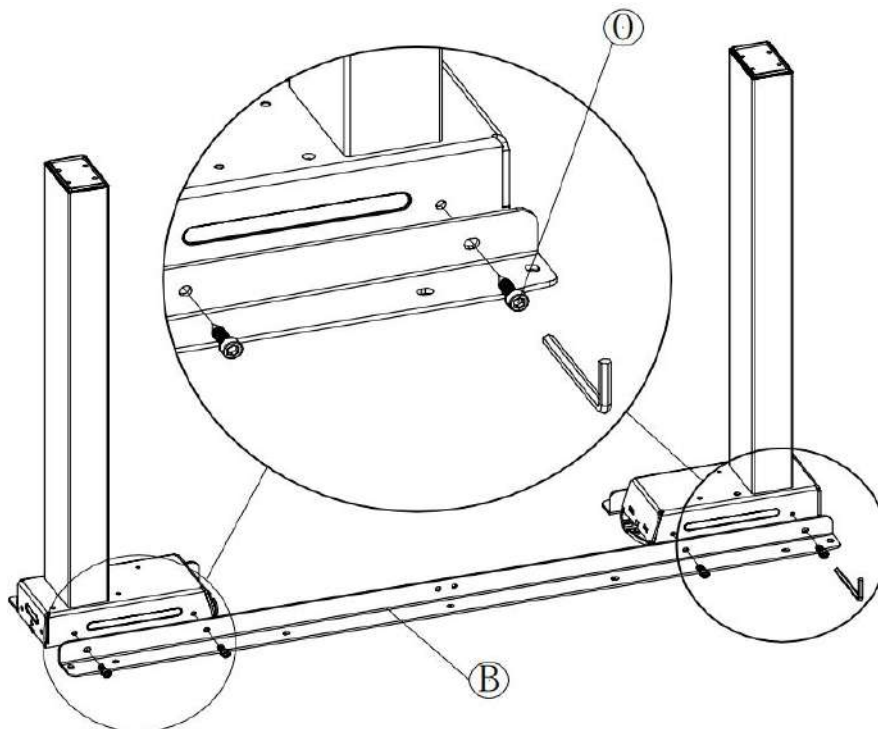

### Checklist

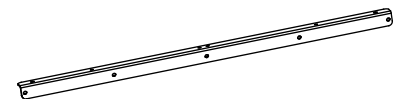

B- Long beam x1



O - M6x15  
Screw x4



M5

# Assembly

## Step 3

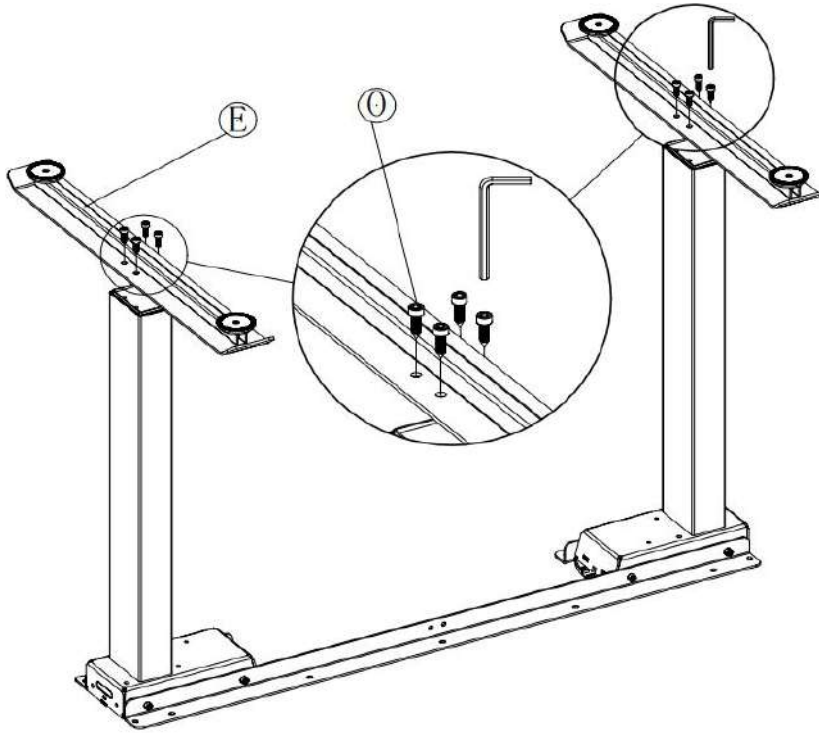

### Checklist

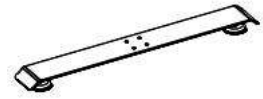

E - Foot ×2



O - M6×15  
Screw ×8



M5

## Step 4

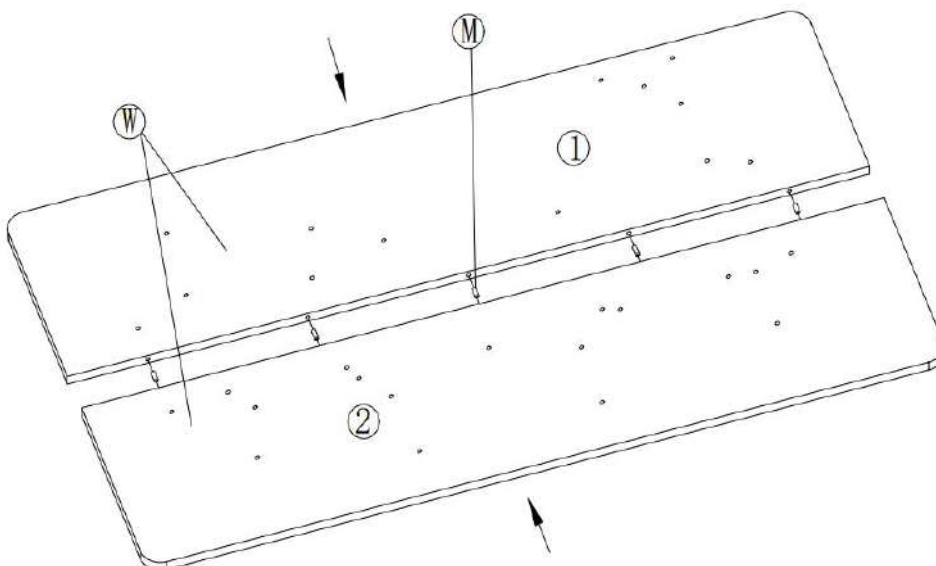

### Checklist

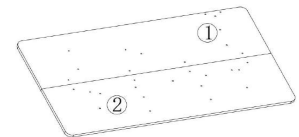

W - Table board 1/2



M - Wooden pin ×4 ( 48" )  
×5 ( 55" )  
×5 ( 63" )



Please make sure the size of the tabletop matches the number of wooden pins

# Assembly

Step 5 ① When the table board length is 55"

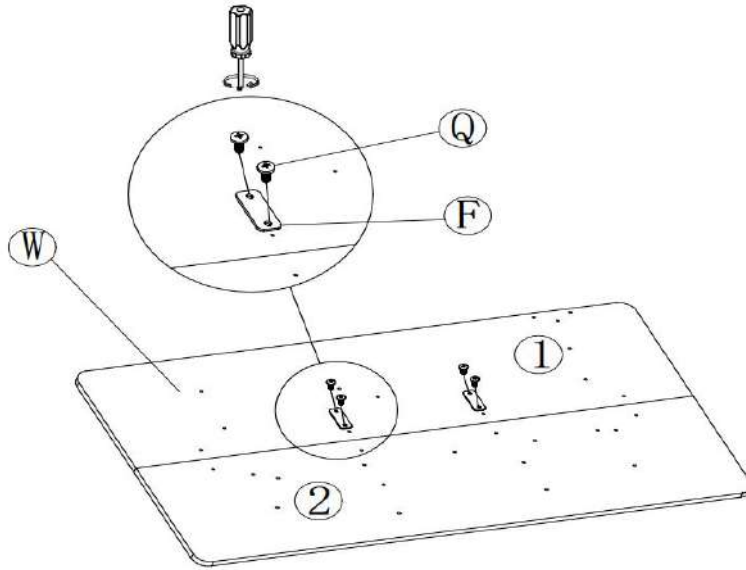

## Checklist

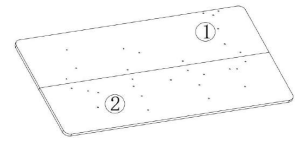

W - Table board 1/2

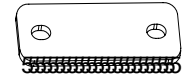

F - Connecting board x2



Q - ST4.8×15 Screw x4



Avoid excessive tightening screws

② When the table board length is 48" or 63"

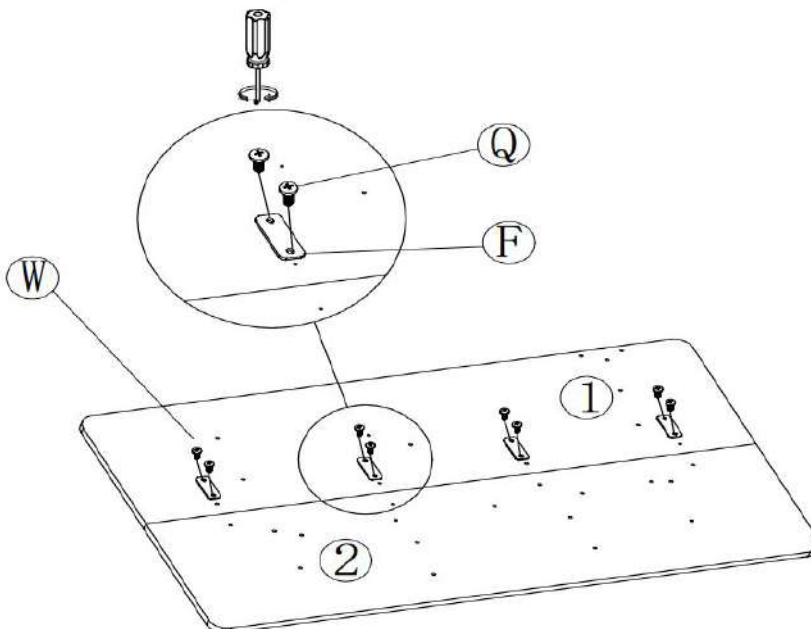

## Checklist

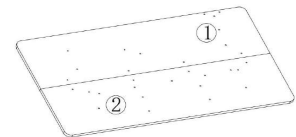

W - Table board 1/2



F - Connecting board x4



Q - ST4.8×15 Screw x8



Avoid excessive tightening screws

# Assembly

## Step 6

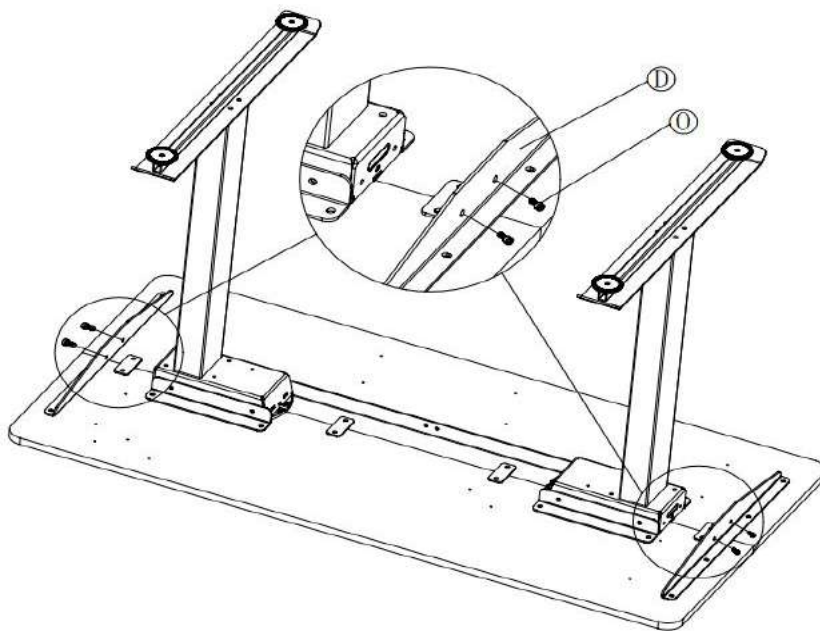

### Checklist

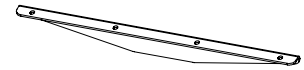

D - Strut x2



O - M6x15 Screw x4

## Step 7

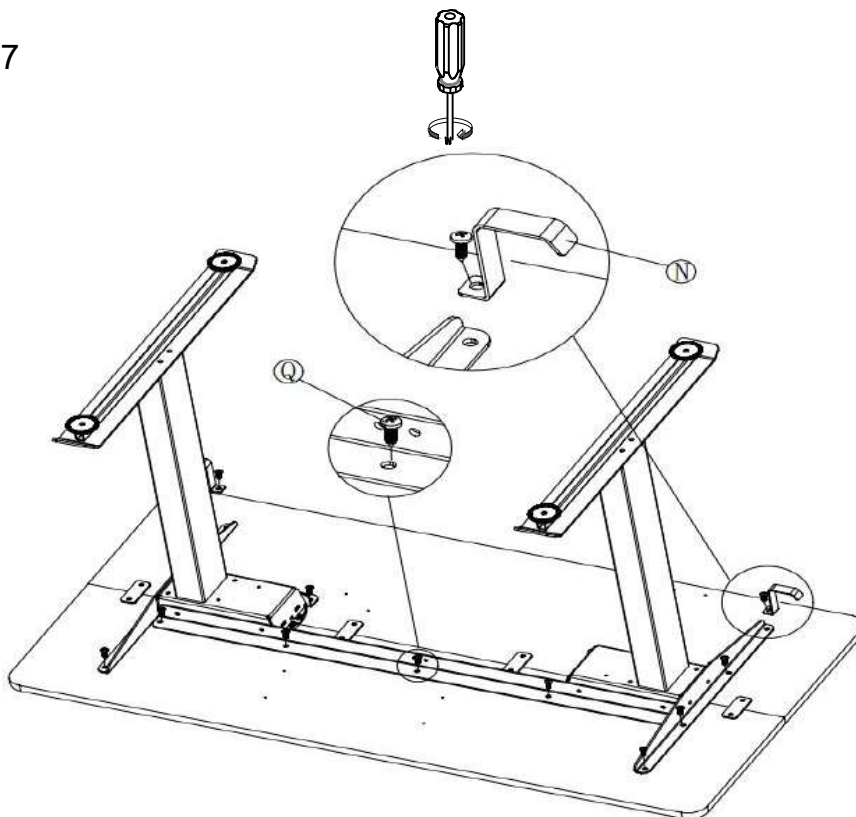

### Checklist



Q - ST4.8x15 Screw x17

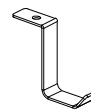

N -Hook x2

 Avoid excessive tightening screws

# Assembly

Step 8

## Checklist

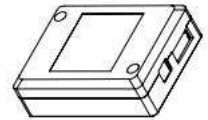

G - Control box ×1

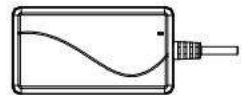

I - Adapter ×1

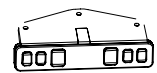

H - Handset ×1



R - ST4.8x19 screw x 2



P - ST4x12 screw x3



K - Cable clip ×5

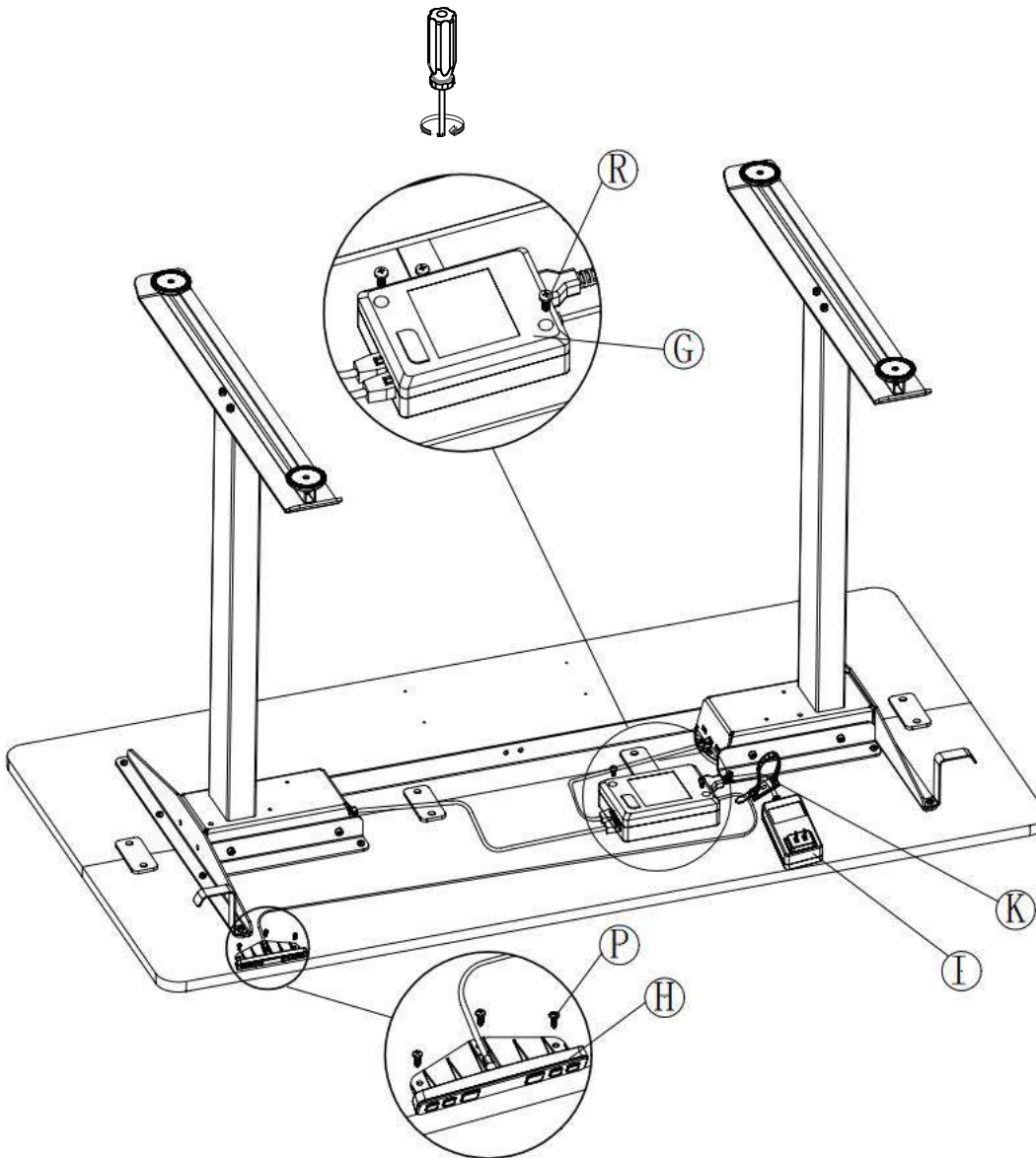

3

 Avoid excessive tightening screws



# Assembly

Step 9

## Checklist

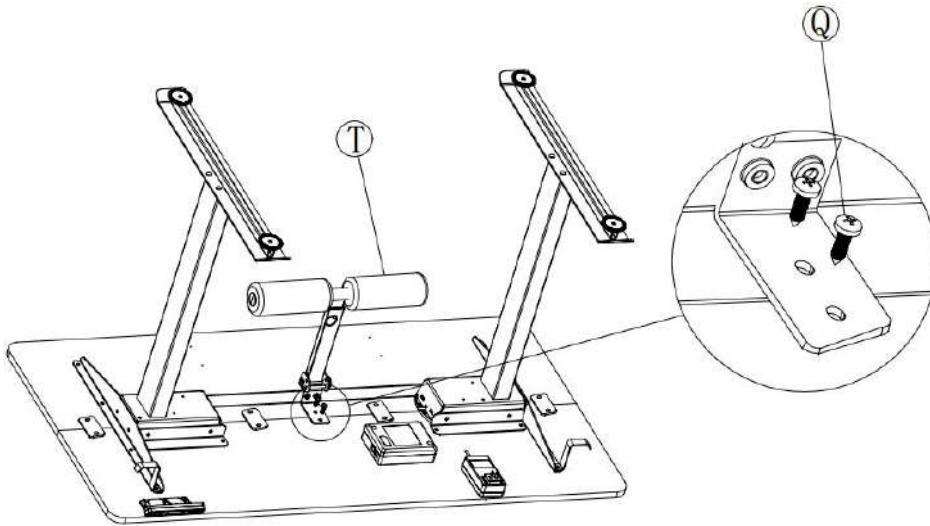

Q - ST4.8x15 screw x 2



S-M6x12 screw x 2

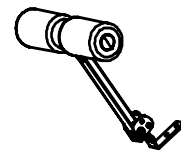
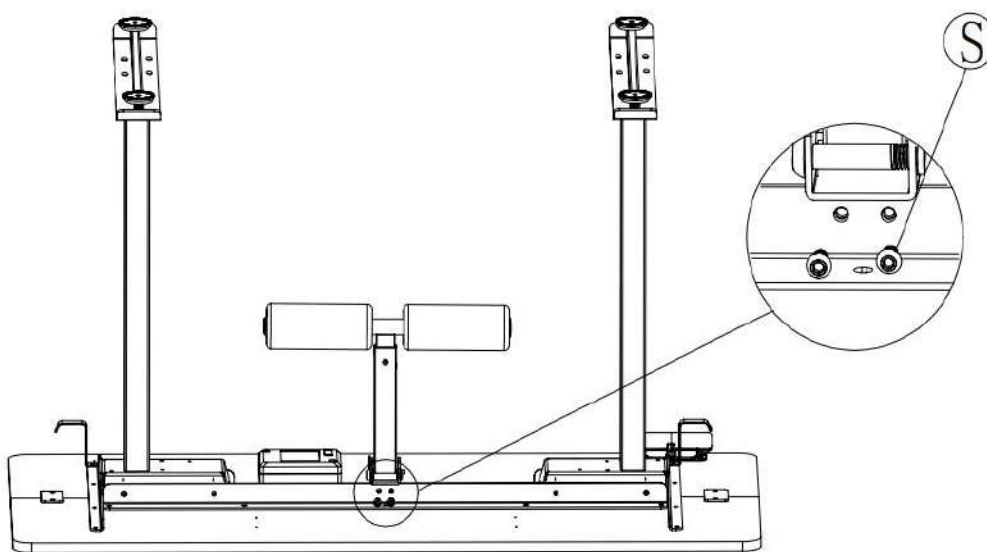

T-Foot supporting x 1



Avoid excessive tightening screws

# Assembly

## Step 10

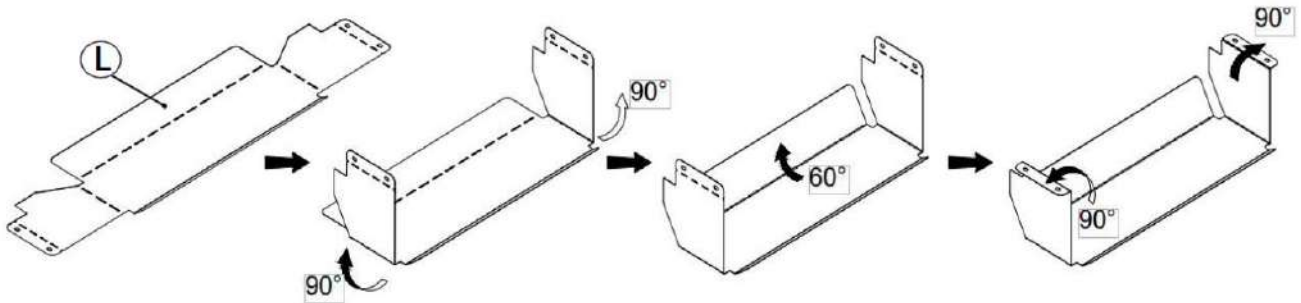

## Step 11

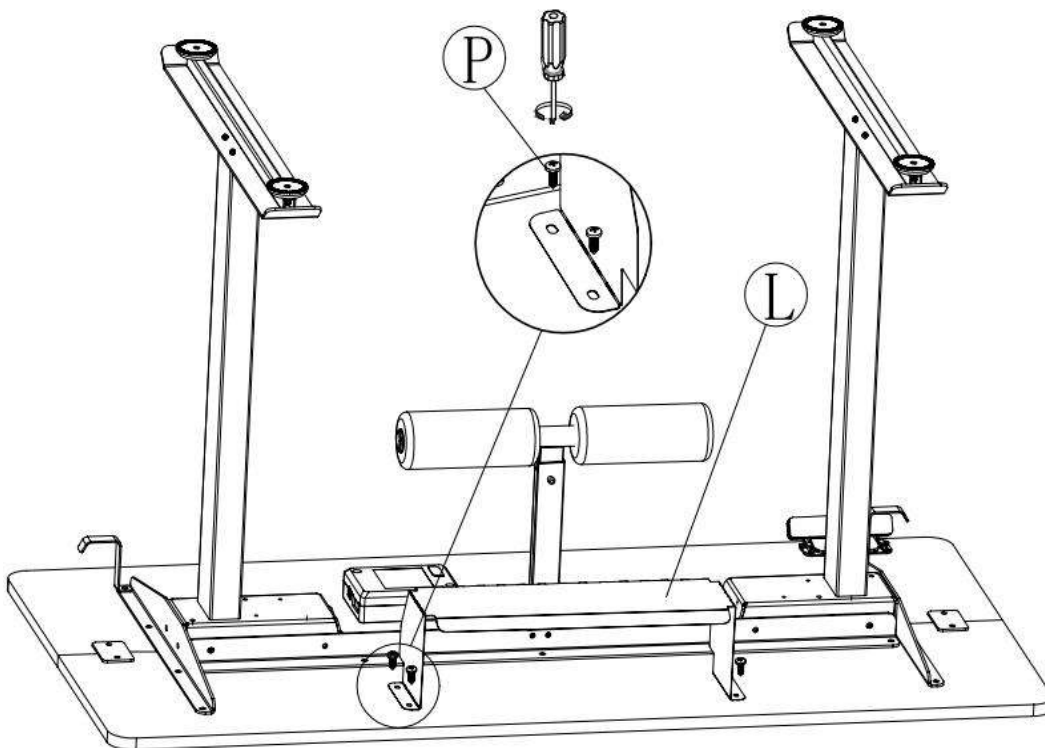

## Checklist

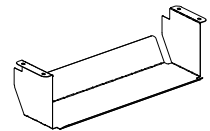

L - Bracket x1



P - ST4x12 screw x 4

 Avoid excessive tightening screws

## FOOT SUPPORTING USER OPERATION INSTRUCTION

### Checklist

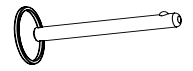
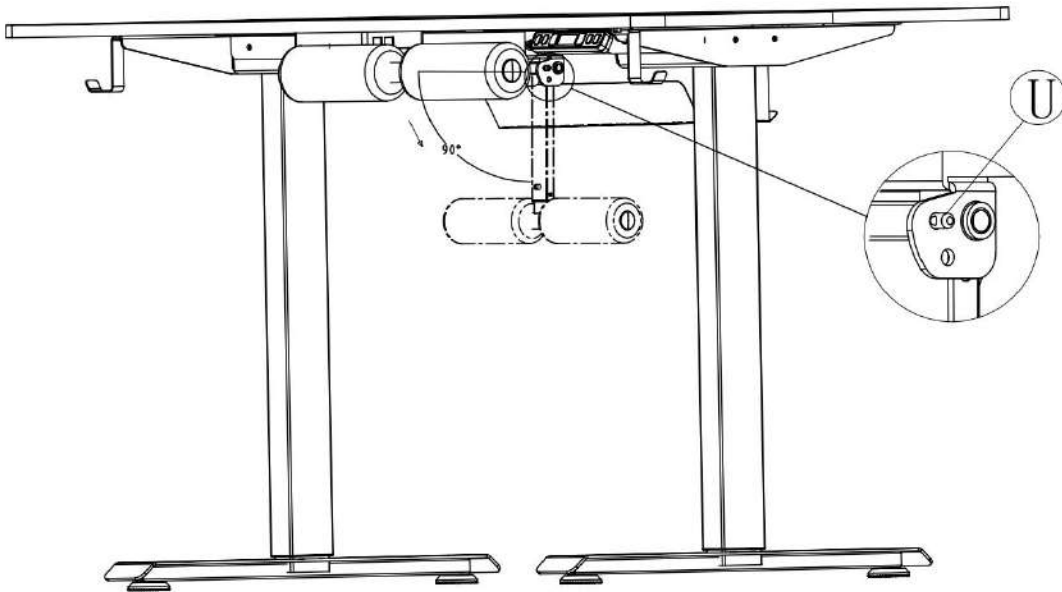

U-Ø6×58 Melt×1

Note: Adjust the position of the pin socket to adjust the angle of the foot support to meet the customer's requirements(before and after adjustment).

### Checklist

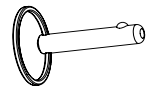
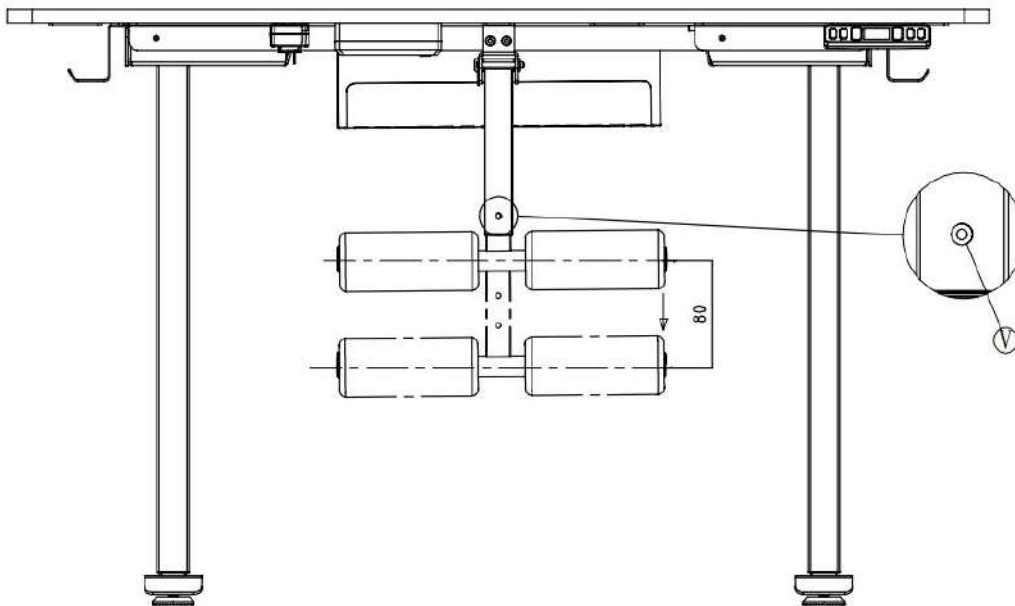

V-Ø8×26 Melt×1

Note: Adjust the position of the pin socket to adjust the height of the foot support to meet the customer's requirements(adjust Up and Down).

# USER OPERATION INSTRUCTION

 Read this instructions before operation

## Digital Handset Operation

### 1. Picture



### 2. Initialization procedure

Step	Operation	Motion
1	Press and hold ▲&▼ simultaneously more than 6 seconds	Legs begin to move down at a half speed of normal operation
2	Keep pressing ▲&▼	Legs move down to the lowest position and rebound 2-5 mm, then stop
3	Release ▲&▼ together	Initialization is completed



The initialization procedure must be completed before the first running after table is installed or parts replaced

### 3. Move up and down

Step	Operation	Motion
1	Press and hold ▲	Legs move up
2	Release ▲	Legs stop
3	Press and hold ▼	Legs move down
4	Release ▼	Legs stop

### 4. Set memory positions

Step	Operation	Motion
1	Press and hold ▲ or ▼, then release	Run the legs to the position you want the table surface to be
2	Click button S, then click button 1 or 2 or 3 within next 6 seconds	Position 1 or 2 or 3 is saved

### 5. Move to the memorized positions

Step	Operation	Motion
1	Press and hold the button 1 or 2 or 3	Legs return to the corresponding position saved

6. Toggle the display unit format

Step	Operation	Motion
1	Press and hold button S, then press and hold ▼, keep about 6 seconds	The height information will be changed between centimeters and inches
2	Release the buttons	completed



In inch format, the minimum height variation as the legs move up or down is 0.5 inches, while in centimeter format is 1 centimeter

7. Verify the display switch data to table height

Step	Operation	Motion
1	Set the table at any height, recommended at the bottom position	Measure the table actual height and write down the number in inches or in centimeters
2	Press and hold button S, then press and hold ▲, keep about 6 seconds	The first number is flashing on the screen
3	Release the buttons, then click ▲ or ▼ to change the first number	The first number is being increased or decreased to the first number you measured
4	Click button S	The second number is flashing on the screen
5	Click ▲ or ▼ to change the number	The second number is being increased or decreased to the second number you measured
6	Click button S	The third number is flashing on the screen
7	Click ▲ or ▼ to change the number	The third number is being increased or decreased to the third number you measured
8	Click button S	Completed



Check the switch display format in inches or in centimeters and toggle to the unit you like and match to the actual measurement. In inch format, the minimum adjustable height is 0.5 inches, while in centimeter format is 1 centimeter.

8. Lock the bottom stroke limit

Step	Operation	Motion
1	Press and hold ▲ or ▼, then release	Run the legs to the position you want the table surface to be
2	Press and hold button S, then press and hold 1, keep about 6 seconds	Letter “L” is indicated on the screen. That means the position is locked at the lowest position that the table can be moved to
3	Release the buttons	Completed



1. Legs aren't able to run below the locked position
2. Memory position(s) are/is below the locked position will lost even after the table is unlocked, you need to follow SET MEMORY POSITIONS again to reset these memory positions
3. Initialize switch will not unlock the top limit.

9.Lock the top stroke limit

Step	Operation	Motion
1	Press and hold ▲or▼, then release	Run the legs to the position you want the table surface to be
2	Press and hold button S, then press and hold 3, keep about 6 seconds	Letter “L” is indicated on the screen. That means the position is locked at the highest position that the table can be moved to
3	Release the buttons	Completed



- 1.Legs aren’t able to run below the locked position
- 2.Memory position(s) are/is below the locked position will lost even after the table is unlocked, you need to follow SET MEMORY POSITIONS again to reset these memory positions
- 3.Initialize switch will not unlock the top limit.

10. Unlock the stroke

Step	Operation	Motion
1	Press and hold button S, then press and hold 2, keep about 6 seconds	Letter “C” is indicated on the screen. That means the table’s unlocked and can be moved in full range
2	Release the buttons	Completed

11.Exception code

Exception code	Abnormal reason	Decision criteria	Troubleshooting and solution
E01	The Column of failure	Disconnect barrier between column and control box	1. Loosen the connection between the column and the control box. Check the connection line to ensure reliable connection 2. The column internal components are damaged, and the column needs to be replaced 3. Try to run the column, and if E01 disappears, troubleshoot
E02	A work schedule function that triggers mandatory rest	It ran continuously for more than 2 minutes	After 18 minutes, try to run the table push and the fault code disappears
E04	Initialization anomaly	1. Initialize interrupt 2. Tilt the table	After the initialization process is interrupted, it needs to be reinitialized. When initialization is complete, the fault code disappears
E05	The key card to death	The hand button is held by the card for 30 seconds	1. The key of the handset is stuck. Check whether the key state is normal 2. Change the handset
E06	Communication interruption	The communication data of the control box cannot be received by the handset for 5 seconds	1. The connection between the handset and the control box is broken. Check whether the connection between the handset and the control box is reliable 2. Check whether the control box is normal

## Why choose FAMISKY?

Many ergonomic office solutions come at high cost. Our mission is to use innovation, creativity, and efficiency to produce a more affordable solution that doesn't sacrifice quality and is easily accessible to the millions of home and office workers globally.



## WARRANTY SERVICE

To provide the best service to you, don't forget to register your FAMISKY product to confirm your warranty.

It only takes a few simple steps and then you can access a wide range of services such as technical support, new product alert, promotions, and warranty service from FAMISKY.

✉ Send your name and order ID to [service@famisky-us.com](mailto:service@famisky-us.com)

For more FAMISKY products, check out our website at: [www.famisky-us.com](http://www.famisky-us.com)