



USER'S GUIDE

OptiMumm™ Smoke Evacuator







User's Guide

OptiMumm™ Smoke Evacuator

Foreword

This manual and the equipment it describes are for use only by qualified medical professionals trained in the particular technique and surgical procedure to be performed. It is intended as a guide for using the Valleylab OptiMumm™ Smoke Evacuator only. Additional technical information is available in the *OptiMumm™ Smoke Evacuator Service Manual*.

Caution

Federal (USA) law restricts this device to sale by or on the order of a physician.

Equipment covered in this manual:

OptiMumm™ Smoke Evacuator – 115 V and 230 V

Part Number: 945 102 097

Effective Date: March 2000

Trademark acknowledgments:

OptiMumm™, RapidVac™, ACCUVAC™, and The EDGE™ are trademarks of Valleylab.

Protected by U.S. Pat. Nos. 5,613,966; 5,456,248; 5,620,441; 4,416,276; 4,416,277; 4,658,820; 5,599,344; 5,628,745.

Manufactured for:

Valleylab, a division of Tyco Healthcare Group LP
Boulder, Colorado 80301-3299 USA

For information call:

1-303-530-2300

Distributed by:

Tyco Healthcare UK Ltd.
Gosport, PO130AS, UK

tyco
Healthcare



Made in USA

Printed in USA

© 2000 Valleylab All rights reserved.

Conventions Used in this Guide

Warning

Indicates a potentially hazardous situation which, if not avoided, could result in death or serious injury.

Caution

Indicates a hazardous situation which, if not avoided, may result in minor or moderate injury.

► Important

Indicates an operating tip or maintenance suggestion.

Notice

Indicates a hazard which may result in product damage.

Table of Contents

Foreword	ii
Conventions Used in this Guide	iii
List of Figures	vi
Section 1. Introducing the OptiMumm Smoke Evacuator	
Parts Shipped with the Smoke Evacuator	1-2
About the OptiMumm Smoke Evacuator	1-2
RapidVac System	1-3
Operating Modes	1-3
Patient and Operating Room Safety	1-4
General	1-4
Maintenance	1-6
Section 2. Controls, Indicators, and Receptacles	
Front Panel	2-2
Side Panel	2-3
Rear Panel	2-4
Section 3. Before Surgery	
Initial Installation	3-2
Installing the Smoke Evacuator on a Valleylab Mounting Cart	3-5
Checking the Smoke Evacuator	3-6
Testing the ULPA Filter	3-6
Changing the ULPA Filter	3-7
Testing the Airflow Controls	3-8
Testing the Footswitch (<i>optional</i>)	3-8
Testing the Electrosurgery Sensor (<i>optional</i>)	3-9
Testing the Generator Interlink (<i>optional</i>)	3-11
Setting Up the Smoke Evacuator	3-12
Open Procedure—Evacuating Dry Smoke	3-12
Open Procedure—Evacuating Smoke and Incidental Fluids	3-13
Section 4. During Surgery	
Initiating Airflow	4-2
Minimizing Noise	4-2
Variables that Affect Airflow	4-2
Changing the Airflow	4-3
Temporarily Turning Off the Airflow	4-3

Periodic Checks	4-3
Fluid Canister	4-3
Tubing	4-3
Prefilter	4-3
Sponge Guard	4-3

Section 5. After Surgery

Preparing the OptiMumm Smoke Evacuator for Reuse	5-2
Removing the Prefilter, Tubing, and Fluid Canister	5-2
Cleaning the Smoke Evacuator	5-4

Section 6. Troubleshooting

Inspecting the OptiMumm Smoke Evacuator	6-2
Correcting Specific Malfunctions	6-2

Section 7. Maintenance and Repair

Routine Maintenance	7-2
Checking the Power Cord	7-2
Removing the ULPA Filter	7-2
Responsibility of the Manufacturer	7-3
Obtaining a Return Authorization Number	7-4
Returning the Smoke Evacuator for Service	7-4
Service Centers	7-5

Appendix A. Technical Specifications

Performance Characteristics	A-1
Dimensions and Weight	A-1
Filters	A-1
Airflow	A-2
Safety	A-2
Power	A-2
Operating Parameters	A-3
Transport and Storage	A-3
Electromagnetic Interference	A-3
Electromagnetic Compatibility (IEC 601-1-2 and IEC 601-2-2)	A-3
Description of Symbols on Unit	A-4
Description of Symbols on Accessories	A-5
Classification	A-5
Class I Equipment (IEC 601-1)	A-5

Appendix B. Accessories

Appendix C. Warranty

List of Figures

- Figure 3-1. Installing the prefilter 3-2
- Figure 3-2. Installing the ULPA filter 3-3
- Figure 3-3. Locking the ULPA filter in place 3-3
- Figure 3-4. Connecting the electrosurgery sensor to the smoke evacuator 3-3
- Figure 3-5. Connecting the generator interlink to the smoke evacuator and the Valleylab generator 3-4
- Figure 3-6. Installing the smoke evacuator on an E8006 or E8008 Mounting Cart 3-5
- Figure 3-7. Removing the ULPA filter 3-7
- Figure 3-8. Connecting the electrosurgery sensor to the smoke evacuator 3-9
- Figure 3-9. Connecting the pencil cord to the electrosurgery sensor 3-10
- Figure 3-10. Connecting the generator interlink 3-11
- Figure 3-11. Connecting tubing to the filter—open procedure 3-13
- Figure 3-12. Connecting tubing to the fluid canister—open procedure 3-14
- Figure 5-1. Disconnecting tubing from the fluid canister 5-3
- Figure 5-2. Disconnecting the prefilter 5-3
- Figure 7-1. Removing the ULPA filter 7-3



Introducing the OptiMumm Smoke Evacuator

This section describes the clinical applications and features of the Valleylab OptiMumm Smoke Evacuator.

Caution

Read all warnings, cautions, and instructions provided with this smoke evacuator before using.

Read the instructions, warnings, and cautions provided with electro-surgical accessories before using. Specific instructions are not included in this manual.

Parts Shipped with the Smoke Evacuator

When you unpack the smoke evacuator, verify that the following parts have been shipped:

- Smoke evacuator
- Smoke evacuator power cord
- User's guide and service manual
- Quick reference card.

Upon initial receipt of the smoke evacuator, inspect the smoke evacuator for dents, cracks, or damage that may have occurred during shipment. If any damage is present, notify the freight carrier for damage assessment. After determining that the smoke evacuator was not damaged during shipment, perform the initial installation as described in Section 3.

About the OptiMumm Smoke Evacuator

The OptiMumm Smoke Evacuator captures particulates and adsorbs gases from surgical smoke. The OptiMumm Smoke Evacuator is specifically designed to improve visibility and reduce potential health hazards associated with surgical smoke.

A centrifugal fan provides suction, drawing the surgical smoke into and through the system. In the first stage of filtration, a single-use prefilter captures gross particulates >0.3 microns in size. Next, an ultra low penetration air (ULPA) filter captures submicron particulates 0.12 microns in size with 99.999% efficiency. The charcoal element in the ULPA filter adsorbs odorous gases.

Features include:

- Three-stage filtration process
- Unique locking ULPA filter
- RapidVac, footswitch, or continuous operation modes
- Quiet operation
- Filter status indicator lights
- Adjustable air flow
- Compatible with all Valleylab electrosurgery pencils and generators.

RapidVac System

► Important

The OptiMumm Smoke Evacuator is designed for use with Valleylab electro-surgical pencils.

The OptiMumm Smoke Evacuator incorporates a system which controls the flow of the smoke evacuator. When the electro-surgical pencil is activated, the smoke evacuator operates in the preselected flow setting. When the pencil is deactivated, the air flow reduces to a low flow purge setting. This mode is enabled by using a Valleylab electro-surgical pencil and an electro-surgery sensor, or a generator interlink connected to the smoke evacuator and to a compatible Valleylab generator.

Operating Modes

Four operating modes are available: standby, footswitch, RapidVac, and continuous.

- *Standby* mode powers up the unit without activating the motor or vacuum flow.
- *Footswitch* mode is used to turn the smoke evacuator on or off with the optional footswitch pedal.
- *RapidVac* mode is used to control the vacuum flow simultaneously with activation of a Valleylab electro-surgical pencil. This mode is controlled with the optional generator interlink or electro-surgery sensor.
- *Continuous* mode is used to operate the smoke evacuator using continuous air flow.

Patient and Operating Room Safety

General

Warning

Electric Shock Hazard — Do not connect a wet power cord to the wall receptacle.

Electric Shock Hazard — Connect the smoke evacuator power cord to a properly grounded receptacle. Plug the power cord directly into the power receptacle without any adapter plugs. Use of power plug adapters may result in electric shock.

Electric Shock Hazard — Do not remove any covers or panels exposing the internal components of the smoke evacuator. Refer to a Valleylab representative for service.

Fuse Replacement — Refer to a Valleylab representative for service.

Fire Hazard — Use of extension cords may result in fire hazards.

The smoke evacuator produces a strong vacuum. Adjust the airflow and the position of the inlet end of the wand or tubing to prevent patient injury and to prevent suction of surgical materials and surgical specimens.

If the smoke evacuator is activated while the airflow is set to a high speed, it may produce a sudden, strong suction action. Check the airflow setting before activating the smoke evacuator to prevent patient injury and to prevent suction of surgical materials and surgical specimens.

Caution

Do not stack equipment on top of the smoke evacuator or place the smoke evacuator on top of electrical equipment. These configurations are unstable and/or do not allow for adequate cooling.

Provide as much distance as possible between the smoke evacuator and other electronic equipment (such as monitors). An activated smoke evacuator may cause interference with them.

Read all warnings, cautions, and instructions provided with the OptiMumm Smoke Evacuator before using.

To maximize patient safety, the tubing or wand should not come in direct contact with tissue. Otherwise, patient injury may result.

Notice

Using any unapproved filter or accessory with the smoke evacuator may cause damage and will void the warranty.

Smoke evacuator performance may be compromised if the prefilter is used for more than one surgical procedure.

The OptiMumm Smoke Evacuator functions properly only when the ULPA filter is installed properly.

Notice

If the Replace Filter indicator illuminates during the filter test, remove and replace the ULPA filter. Failure to do so may reduce airflow and compromise the efficiency of the filter.

Fluids may damage the filters. When evacuating smoke and incidental fluids, always use the appropriate tubing, Valleylab E3620 Fluid Canister Ring, and E3680 Fluid Canister Kit.

Check the fluid level in the canister frequently during surgery.

If the fluid canister overfills, smoke evacuator damage will result.

Due to the high velocity of air when using 2.2 cm (7/8 in.) tubing, the maximum fluid level in the canister should be 600 cc.

To prevent clogging and/or damage to the ULPA filter, always operate the smoke evacuator with the prefilter installed.

Connect the power cord to a wall receptacle having the correct voltage. Otherwise, product damage will result.

Power line voltage below 100 Vac (OptiMumm 115 V) and 200 Vac (OptiMumm 230 V) will significantly reduce airflow.

When using the electrosurgery sensor and an electrosurgical pencil in cut or coag mode, the remote unit requires a minimum of 10 watts.

Connecting multiple lengths of tubing together may cause the smoke evacuator to overheat.

The OptiMumm Smoke Evacuator has been specially designed to fit on Valleylab mounting carts only. Do not install the smoke evacuator on a cart other than a Valleylab cart. Installing the smoke evacuator inside a cart with improper ventilation may result in overheating or may impact the stability of the cart.

Periodically check the cart brackets that hold the smoke evacuator in place to ensure that the screws are securely fastened.

Stacking the smoke evacuator on top of a generator may cause an unstable condition and/or cause the smoke evacuator to overheat.

Do not use sterile accessory products if sterile packaging has been compromised.

Maintenance

Warning

Electric Shock Hazard — Always turn off and unplug the smoke evacuator before cleaning.

Caution

The prefilter and ULPA filter capture potentially hazardous particles. Handle used filters as you would any biohazardous material. Dispose of the filters with other operative waste materials according to the procedures for your institution.

Do not reuse or resterilize smoke evacuator accessories labeled “disposable,” “single use only” or “sterile.”

Notice

Do not rub, touch, or clean the smoke evacuator with alcohol or caustic, corrosive, or abrasive cleaning or disinfectant compounds, solvents, or other materials that could scratch the control panel or damage the smoke evacuator.

Do not autoclave, pressure sterilize, or gas sterilize the smoke evacuator.

Keep the smoke evacuator away from liquids. Liquids that enter the smoke evacuator will damage internal components.

There are no internal user serviceable parts. For repairs, return the smoke evacuator to Valleylab.



Controls, Indicators, and Receptacles

This section describes the front, side, and rear panels on the smoke evacuator, including all controls, indicators, receptacles, and ports.

Front Panel

ULPA Filter Status Indicators

When you press the Filter Test Button, the Pass indicator illuminates green if the filter is functioning properly. The Replace indicator illuminates as follows:

- Red (filter warning, replace filter)
- Blinking red (ULPA filter not properly installed).

Vacuum Flow Indicators

Indicate selected air flow setting.

Vacuum Flow Selector

Variable flow dial control with unlimited airflow settings.

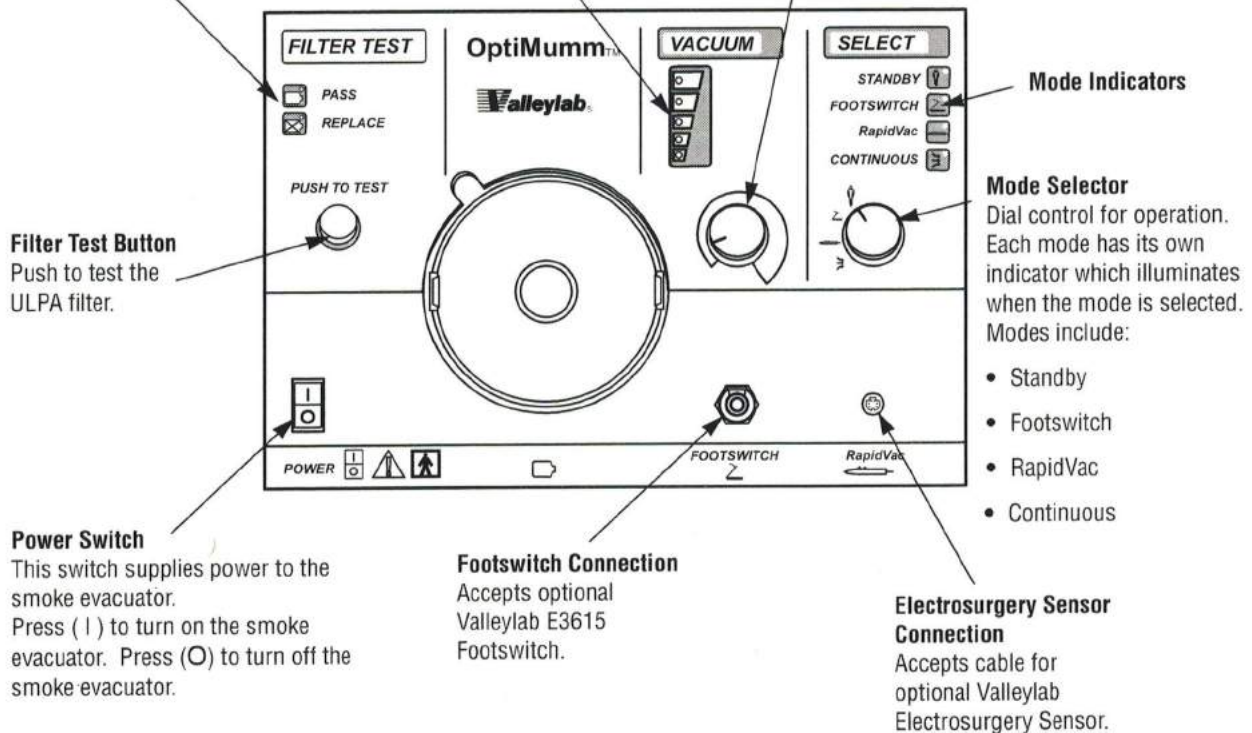

Side Panel

The OptiMumm Smoke Evacuator has two small holes on the left side panel to accommodate a 1200 cc fluid canister by means of the optional Valleylab E3620 Fluid Canister Ring and E3680 Fluid Canister Kit.

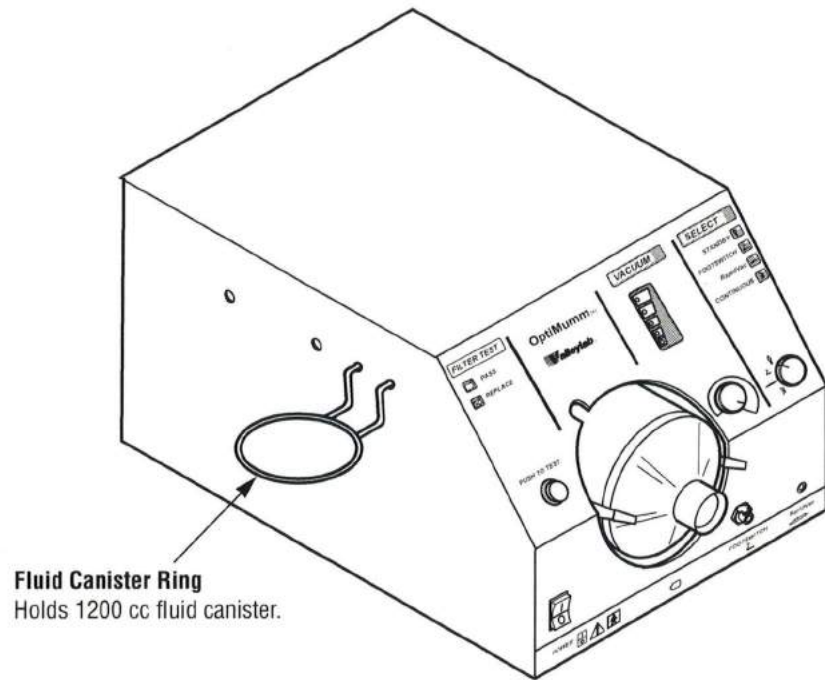

Rear Panel

Generator Interlink Connection

Accepts optional Valleylab Generator Interlink connection for use with compatible Valleylab generators.

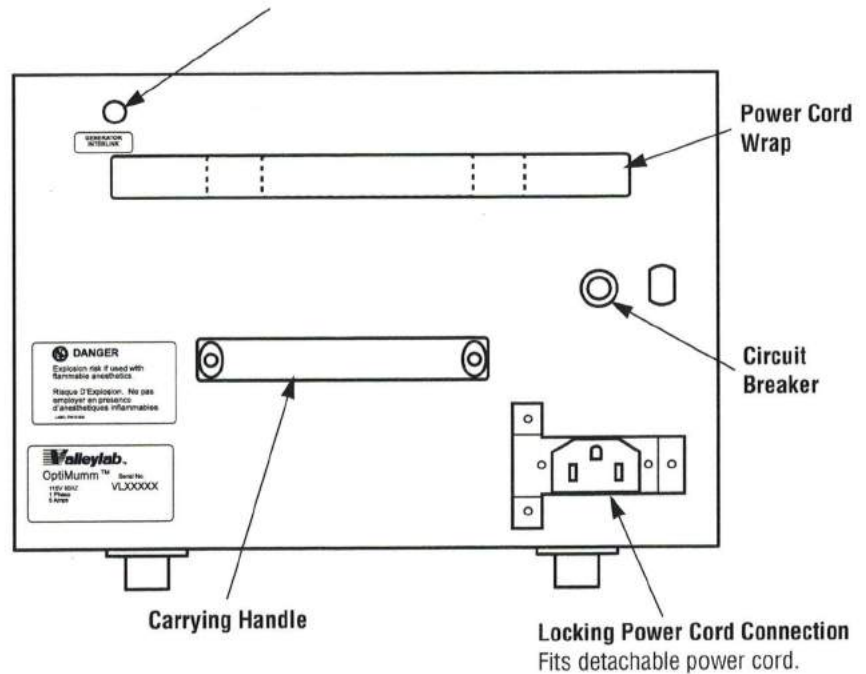

Caution

Connect accessories to the proper receptacle type. Otherwise, the smoke evacuator may not function properly.

Accessory equipment connected to interfaces must be certified according to IEC 601-1-1. All configurations shall comply with the system standard IEC 601-1-1. The user is responsible for verifying that accessory equipment connections comply with the system requirements of IEC 601-1-1. If in doubt, contact Valleylab.

Before Surgery

This section contains procedures for:

- Initial installation
- Checking and testing the smoke evacuator prior to use
- Preparing for evacuation of dry smoke (open procedure)
- Preparing for evacuation of smoke and incidental fluids (open procedure).

Caution

Read all warnings, cautions, and instructions provided with this smoke evacuator before using.

Read the instructions, warnings, and cautions provided with electrosurgical accessories before using. Specific instructions are not included in this manual.

Initial Installation

To prepare the OptiMumm smoke evacuator for use, you must verify that the filters are installed, connect the appropriate tubing, and check the performance of the smoke evacuator indicators and controls.

Warning

Connect the smoke evacuator power cord to a properly grounded, hospital grade receptacle. Plug the power cord directly into the power receptacle without any extension cords and/or adapter plugs.

Notice

Connect the power cord to a wall receptacle having the correct voltage. Otherwise, product damage will result.

Stacking the smoke evacuator on top of a generator may cause an unstable condition and/or cause the smoke evacuator to overheat.

1. Inspect the power cord for any signs of visible damage. If it is in good condition, plug the power cord into a grounded wall receptacle.
2. Turn the Mode Selector to standby.
3. Turn on the smoke evacuator using the power switch on the front panel.
4. Install the prefilter (E3630) onto the ULPA filter (E3625), as shown in Figure 3-1.

Figure 3-1.
Installing the prefilter

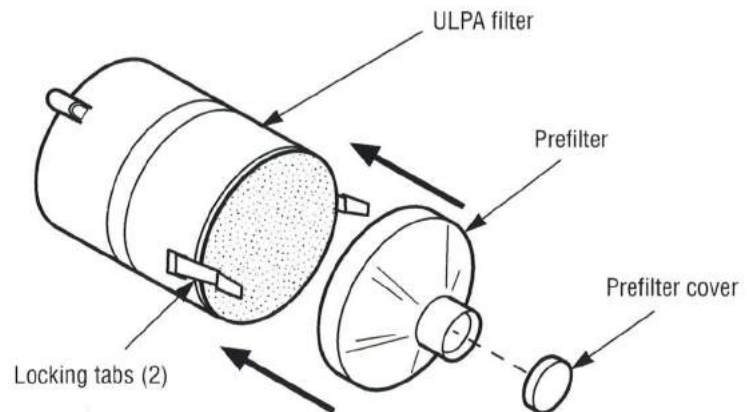

5. Install the ULPA filter as shown in Figure 3-2. Turn clockwise to lock the filter in place, as shown in Figure 3-3. The Replace Filter Status Indicator blinks red if the filter is improperly installed.
6. Remove the prefilter cover from the prefilter, as shown in Figure 3-1.

Figure 3-2.
Installing the ULPA filter

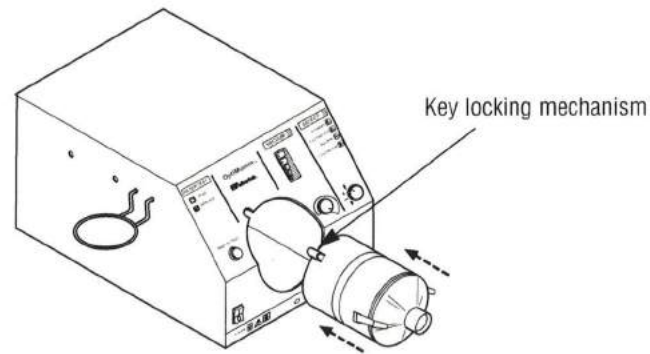
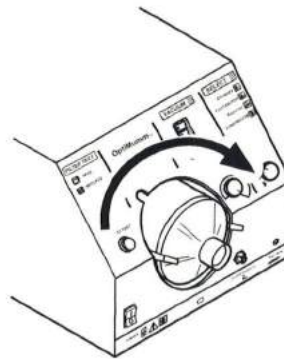
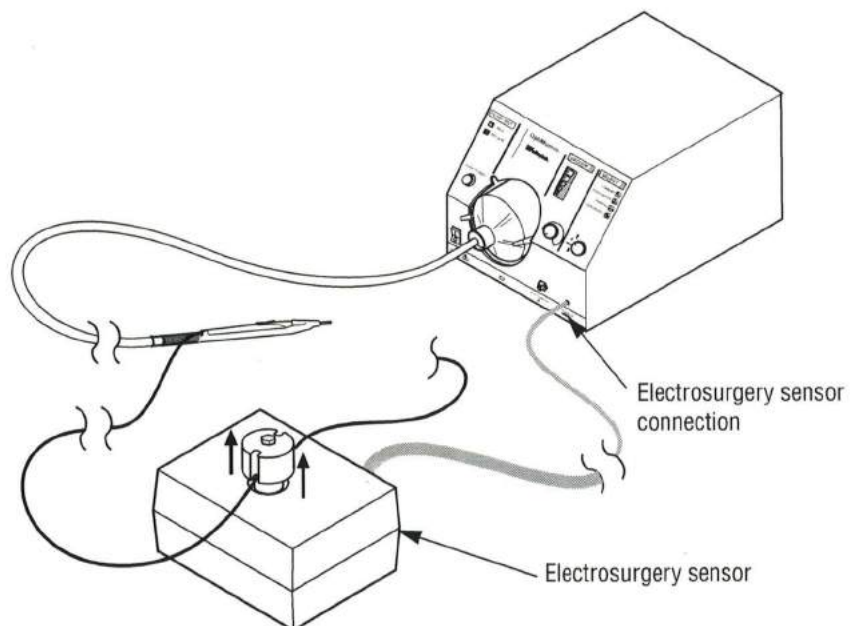

Figure 3-3.
Locking the ULPA filter in place



7. (Optional) Connect the Valleylab electrosurgery sensor to the RapidVac connection on the front panel of the smoke evacuator, as shown in Figure 3-4. Only use the Valleylab electrosurgery sensor. Other remote units are not compatible.

Figure 3-4.
Connecting the electrosurgery sensor to the smoke evacuator



8. (Optional) Connect the Valleylab generator interlink to the back panel of the smoke evacuator and to the rear panel of the compatible Valleylab generator, as shown in Figure 3-5.

Figure 3-5.
Connecting the generator interlink to the smoke evacuator and the Valleylab generator

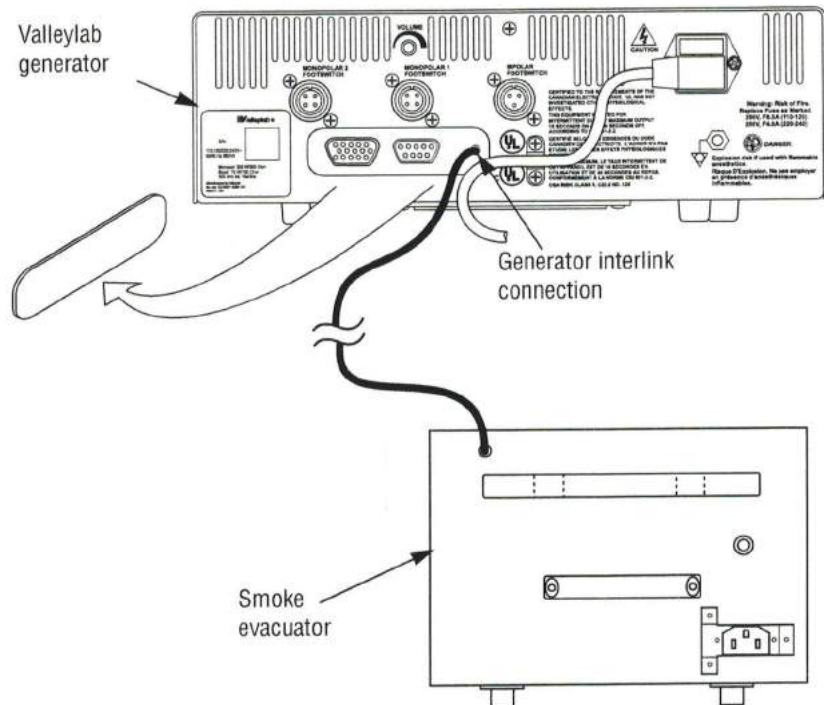

9. (Optional) Connect the Valleylab E3615 Footswitch to the front panel of the smoke evacuator. Only use the Valleylab E3615 Footswitch with the smoke evacuator. Other footswitches are not compatible.
10. (Optional) Remove the covers over the canister ring holes. Connect the Valleylab E3620 Fluid Canister Ring to the side of the smoke evacuator. Only use the Valleylab E3620 Fluid Canister Ring. Other canister rings are not compatible.

Installing the Smoke Evacuator on a Valleylab Mounting Cart

The smoke evacuator may be placed on either the primary, secondary, or suspended shelf of the Valleylab UC8009 Universal Mounting Cart. For use with Valleylab's E8006 and E8008 Mounting Carts, see Figure 3-6.

Notice

The OptiMumm Smoke Evacuator has been specially designed to fit on Valleylab Mounting Carts only. Do not install the smoke evacuator on a cart other than a Valleylab cart. Installing the smoke evacuator inside a cart with improper ventilation may result in overheating or may impact the stability of the cart.

1. Install the cart brackets (E3610) on each side of the middle cart shelf, as shown in Figure 3-6.

Figure 3-6.
Installing the smoke evacuator on
an E8006 or E8008 Mounting Cart

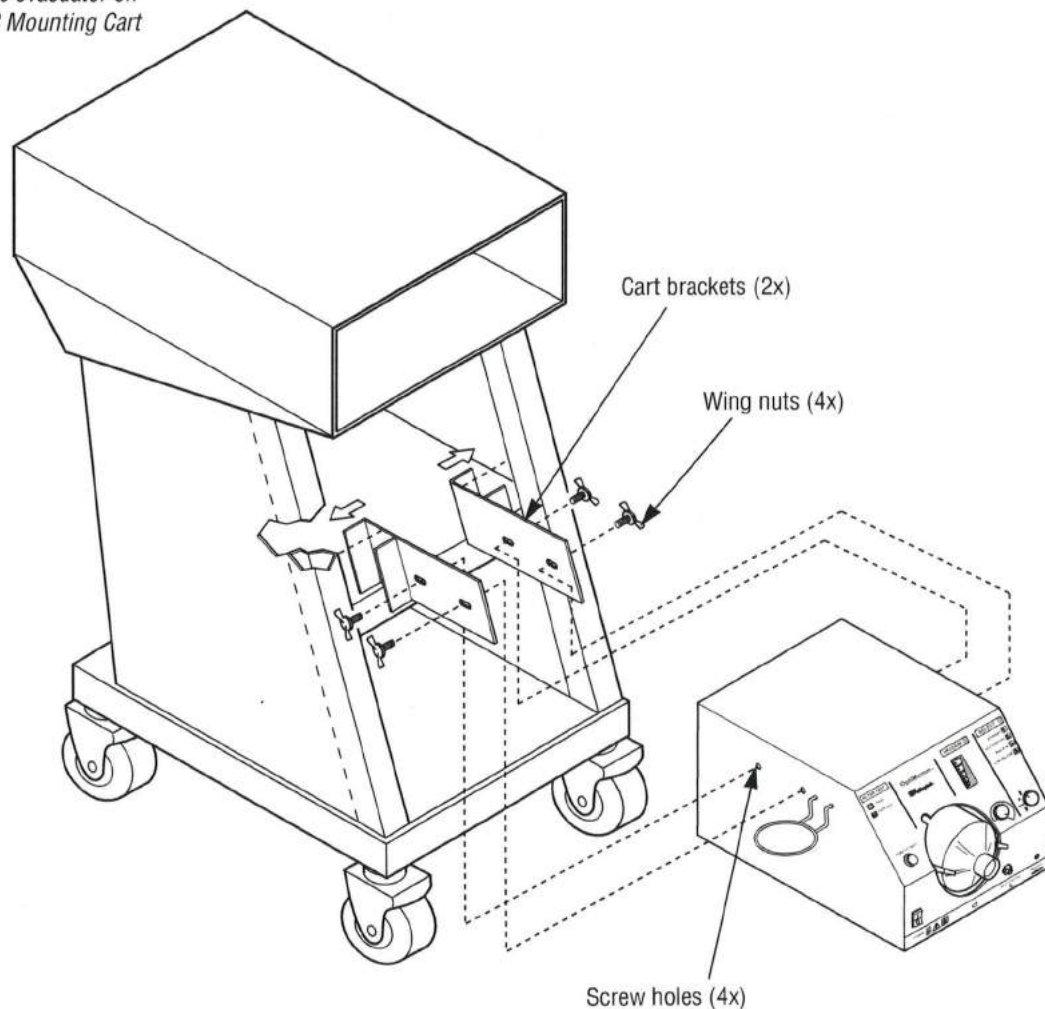

2. Verify that the power cord is plugged into the smoke evacuator and the cord retainer is installed.

3. If using the generator interlink, plug the cable into the back of the smoke evacuator.
4. Remove the two rear feet on the smoke evacuator.
5. Pass the power cord and generator interlink through the opening located on the top of the middle shelf enclosure.
6. Install the smoke evacuator on the middle shelf of the cart. Small tabs on the bottom of the smoke evacuator are designed to lock the unit in place on the front lip of the center shelf.
7. Use the screws provided with the cart brackets to secure the smoke evacuator to the cart, as shown in Figure 3-6.

Notice

Periodically check the cart brackets that hold the smoke evacuator in place to ensure that the screws are securely fastened.

Checking the Smoke Evacuator

Before use, test the following smoke evacuator components to verify performance:

- The ULPA filter
- The airflow controls
- The footswitch (as applicable)
- The electrosurgery sensor (as applicable)
- The generator interlink (as applicable).

If the system does not respond as indicated below, refer to Section 6, *Troubleshooting*.

Testing the ULPA Filter

Test the ULPA filter with a new prefilter and no tubing or adapters installed. The Mode Selector can be set to any position when testing the ULPA filter.

► Important

If the ULPA filter is properly installed, but you have not yet performed the filter test, the Filter Status Indicators will not illuminate.

1. Before the filter test, verify the ULPA filter is properly installed and that the prefilter cover is removed. If the Replace Filter Status Indicator is blinking, the filter is not properly installed.

Important

If the **Replace Filter Status** Indicator illuminates after performing the filter test cycle, replace the ULPA filter. Failure to replace the ULPA filter may reduce airflow and compromise the efficiency of the filter.

2. Press the Filter Test button to test the ULPA filter. While the test is occurring, the Filter Status Indicators will blink alternating green and red. The filter test lasts approximately five seconds. After the test is complete:
 - If the Pass Filter Status Indicator illuminates green, the filter is functioning properly.
 - If the Replace Filter Status Indicator illuminates red, replace the ULPA filter as described earlier in this section.
 - If the Replace Filter Status Indicator illuminates blinking red, the filter is not properly installed. Reposition the filter and retest.

Changing the ULPA Filter

1. Remove the ULPA filter by turning the filter assembly counterclockwise and pulling it out of the smoke evacuator, as shown in Figure 3-7.
2. Dispose of the prefilter, tubing, and ULPA filter with other operative waste materials according to the procedures for your institution.
3. Install a new E3630 Prefilter in the smoke evacuator, as described earlier in this section.

Figure 3-7.
Removing the ULPA filter

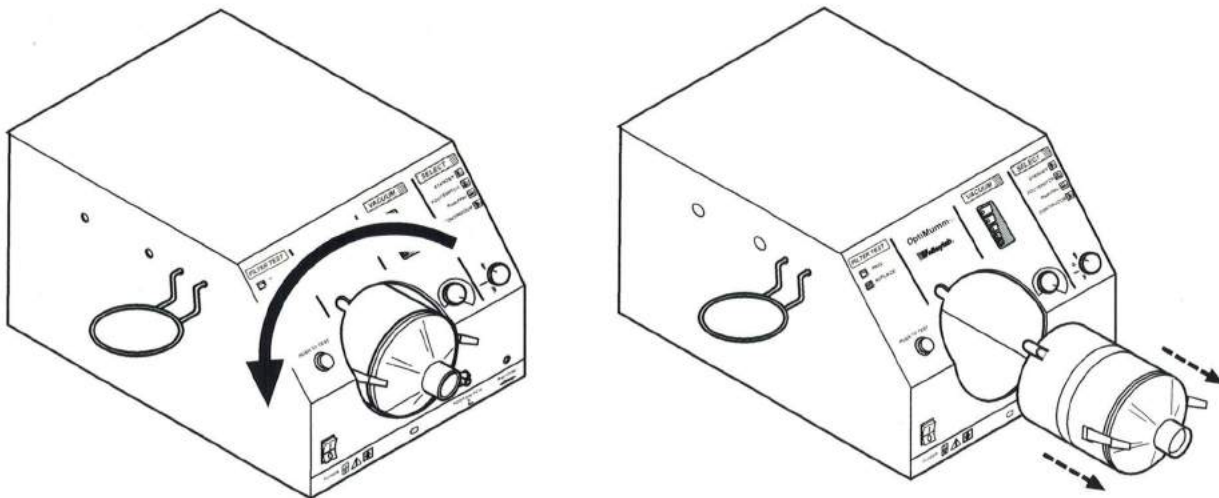

Before Surgery

Testing the Airflow Controls

Warning

The smoke evacuator produces a strong vacuum. Properly adjust the airflow and the position of the inlet end of the wand or tubing to prevent patient injury and to prevent suction of surgical materials and surgical specimens.

► Important

The Vacuum Flow Indicators always show the flow setting of the Vacuum Flow Selector. The indicators illuminate sequentially in any mode selected.

You can change the vacuum airflow rate when the smoke evacuator is on. An illuminated Vacuum Flow Indicator specifies the airflow setting. When you place the smoke evacuator in standby mode, the airflow rate that you set previously remains in effect.

1. Verify that the ULPA filter and prefilter are installed. Verify that the prefilter cover is removed.
2. Ensure that the power cord is plugged into a hospital grade power receptacle.
3. Check that the Mode Selector is set to standby and that the standby indicator illuminates.
4. Check the power switch on the lower left of the smoke evacuator front control panel. It should be on (|). If it is off (O), turn it on.
5. Set the airflow to maximum by turning the Vacuum Flow Selector clockwise.
6. Turn the Mode Selector to continuous. Verify that the vacuum flow changes from high to low and that the Vacuum Flow Indicators turn off as the motor speed decreases.
7. Test the footswitch as described below.

Testing the Footswitch (optional)

Only use the Valleylab E3615 Footswitch with the smoke evacuator. Other footswitches are not compatible. Use the footswitch to activate the smoke evacuator in footswitch mode.

1. Ensure that the footswitch is connected to the smoke evacuator. If it is not, connect the footswitch to the front panel of the smoke evacuator.
2. The smoke evacuator should be on and in footswitch mode (the Footswitch indicator illuminates).
3. Set the airflow to maximum by turning the Vacuum Flow Selector clockwise.
4. Press the footswitch once to activate the airflow.
5. Press the footswitch again to turn off the airflow.

Testing the Electrosurgery Sensor (optional)

Use the Valleylab electrosurgery sensor with any of Valleylab's electrosurgical pencils and generators.

Notice

When using the electrosurgery sensor and an electrosurgical pencil in cut or coag mode, the remote unit requires a minimum of 10 watts.

1. Plug the electrosurgery sensor cable into the electrosurgery sensor connector on the front of the smoke evacuator, as shown in Figure 3-8.
2. Locate the electrosurgery sensor cable in close proximity to the front of the electrosurgery generator.
3. Turn the smoke evacuator on and turn the Mode Selector to RapidVac.
4. Set the airflow to maximum by turning the Vacuum Flow Selector clockwise as far as it will turn.

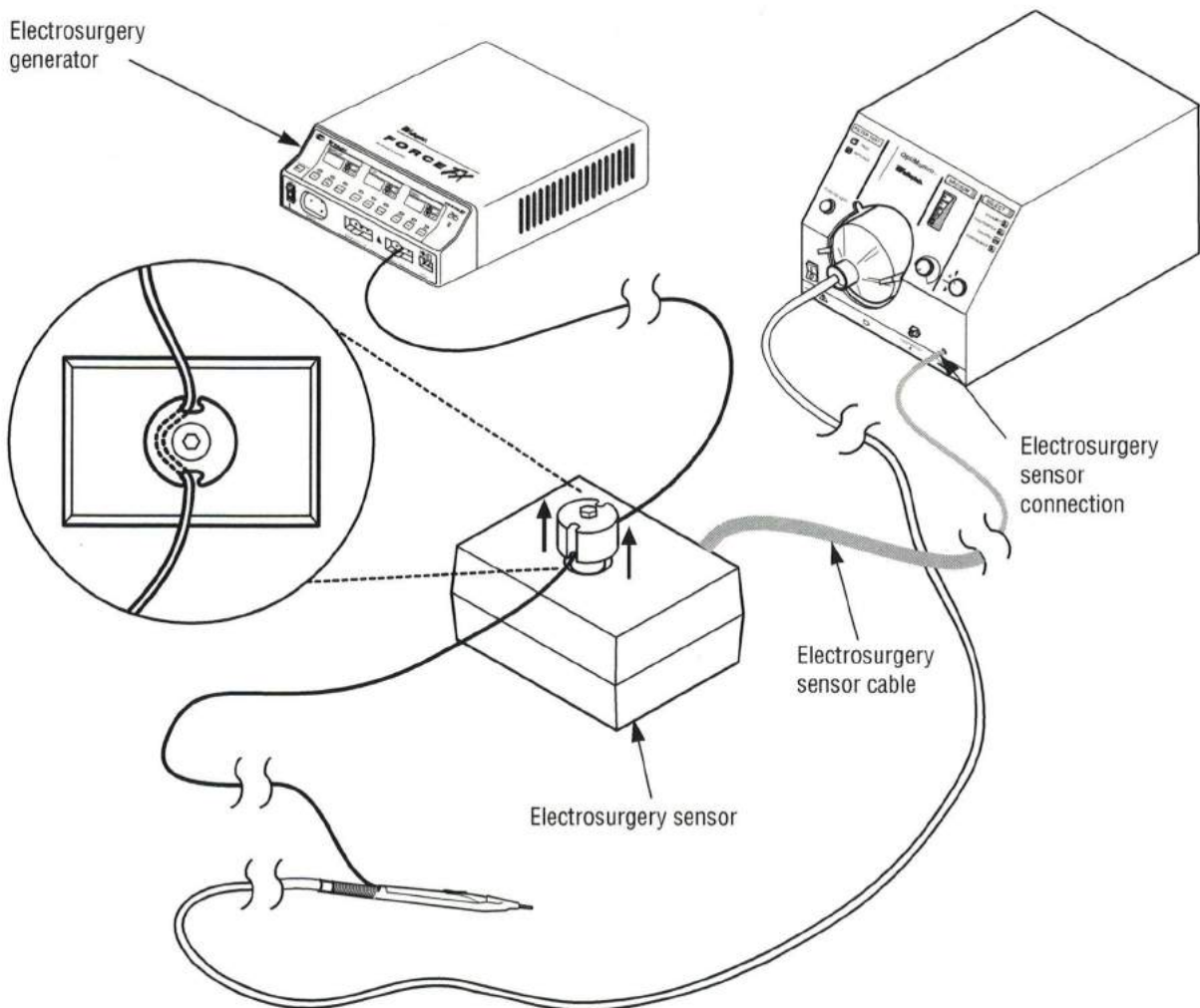
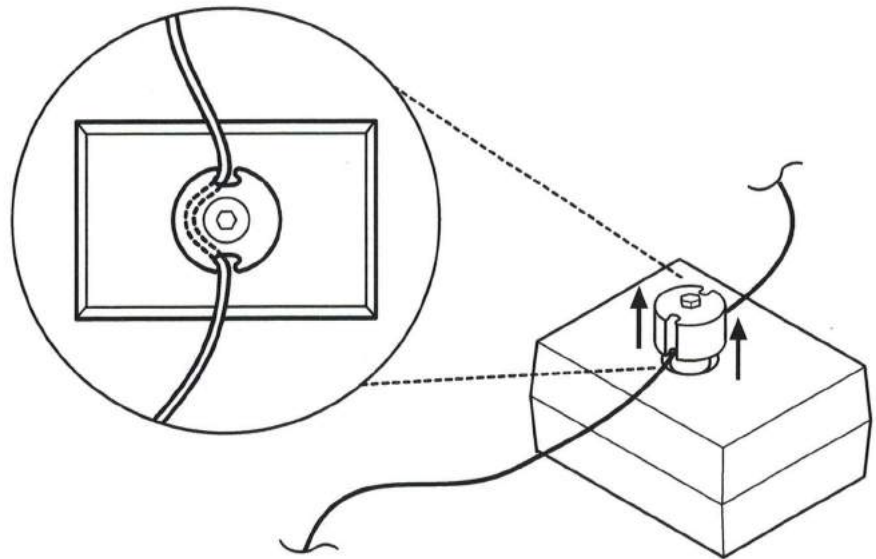

Figure 3-8.
Connecting the electrosurgery sensor to the smoke evacuator

5. Connect the electrosurgical pencil cord to the electrosurgery sensor, by threading the pencil cord through the bobbin cutouts, as shown in Figure 3-9.
6. Connect the plug of the electrosurgical pencil cord to the generator.
7. When you activate the electrosurgical pencil, the smoke evacuator should activate to the preselected flow level.
8. When you deactivate the pencil, the smoke evacuator should return to a low flow purge setting after a momentary delay; the delay allows the smoke evacuator to clear away any remaining smoke.

Figure 3-9.
Connecting the pencil cord to the
electrosurgery sensor



Testing the Generator Interlink (optional)

The generator interlink works with compatible Valleylab generators that have a compatible connector.

1. Plug the generator interlink cable into the generator interlink connection on the rear panel of the smoke evacuator, as shown in Figure 3-10.
2. Plug the other end of the generator interlink cable into the generator interlink connection on the back of the Valleylab generator.
3. Turn the smoke evacuator on and turn the Mode Selector to RapidVac.
4. Adjust the power setting to maximum by turning the Vacuum Flow Selector clockwise.
5. When you activate the electrosurgical pencil, the smoke evacuator should activate to the preselected air flow level.
6. When you deactivate the pencil, the smoke evacuator should return to a low flow purge setting after a momentary delay; the delay allows the smoke evacuator to clear away any remaining smoke.

Figure 3-10.
Connecting the generator interlink

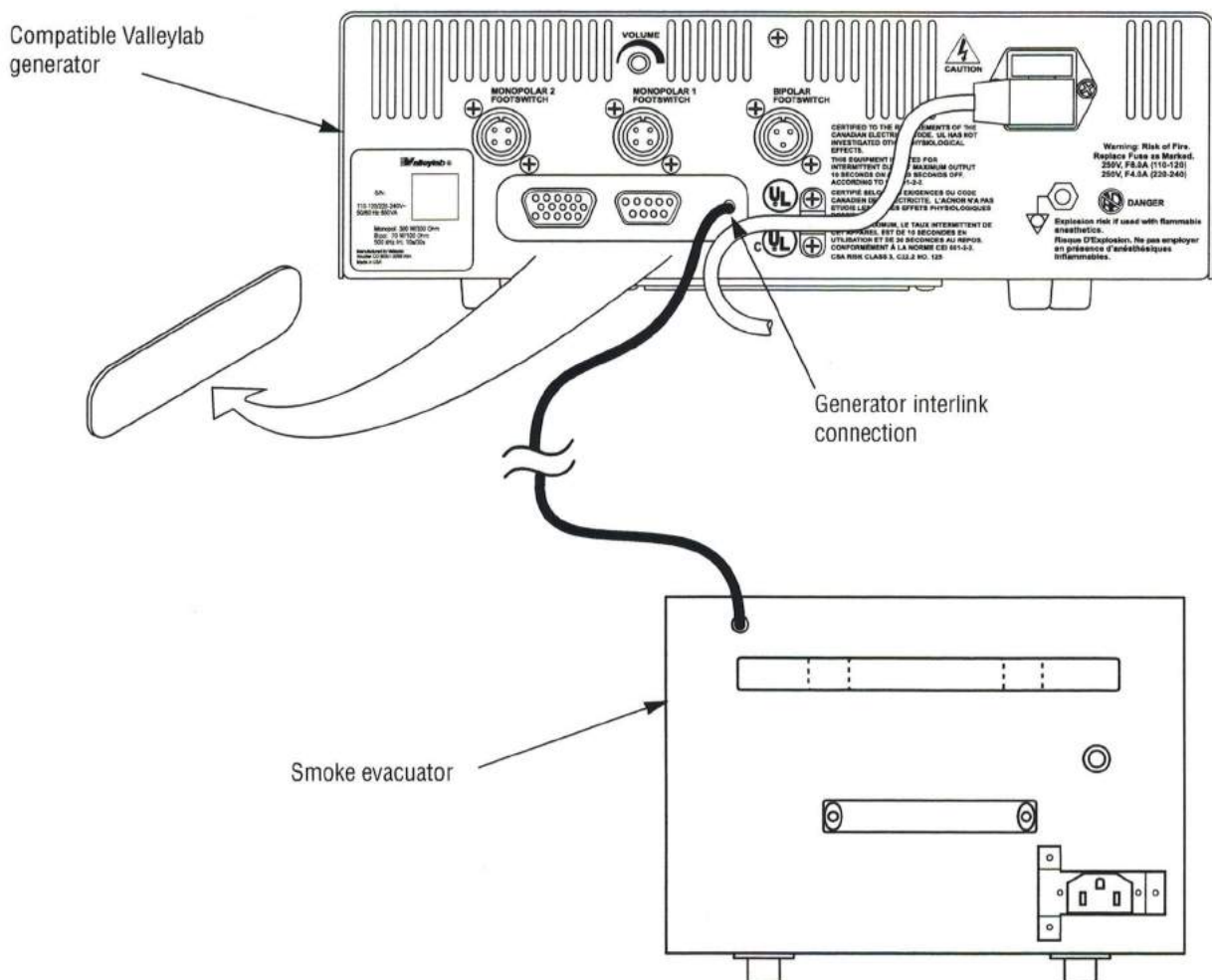

Before Surgery

Setting Up the Smoke Evacuator

Warning

Electric Shock Hazard — Connect the smoke evacuator power cord to a properly grounded receptacle. Plug the power cord directly into the power receptacle without any adapter plugs. Use of power plug adapters may result in electric shock.

Fire Hazard — Use of extension cords may result in fire hazards.

Use the smoke evacuator only if the filter test has been completed as described earlier in this section. Otherwise, the smoke evacuator may not perform properly.

After the initial installation, set up the smoke evacuator for use. This section describes how to set up for the following procedures:

- Open procedure—evacuating dry smoke
- Open procedure—evacuating smoke and incidental fluids.

Open Procedure—Evacuating Dry Smoke

Notice

Connecting multiple lengths of tubing together may cause the smoke evacuator to overheat.

1. Install a new prefilter (E3630) in the smoke evacuator, and remove the prefilter cover as described earlier in this section.
2. Test the ULPA filter as described earlier in this section.
3. Connect your choice of tubing and applicable adapter to the prefilter, as shown in Figure 3-11.
4. Check the smoke evacuator before use as described earlier in this section.

Figure 3-11.
Connecting tubing to the filter
—open procedure

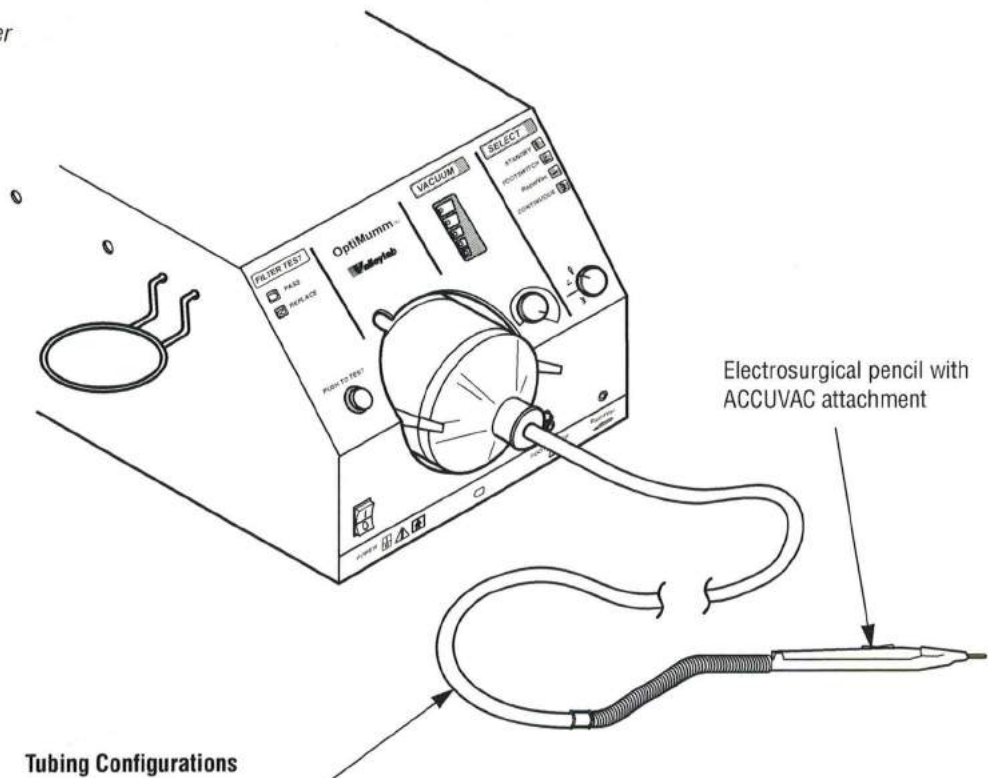

Tubing Configurations

- E3645 – 1 cm x 3 m (3/8 in. x 10 ft), sterile, E3660 prefilter adapter, and ACCUVAC attachment
- E3635 – 2.2 cm x 3 m (7/8 in. x 10 ft), sterile (includes E3665 prefilter adapter)
- E3640 – 2.2 cm x 3 m (7/8 in. x 10 ft), nonsterile (includes E3665 prefilter adapter)

Open Procedure—Evacuating Smoke and Incidental Fluids

The primary function of the smoke evacuator is to evacuate surgical smoke. A fluid canister is recommended to prevent the filters from getting wet when evacuating smoke that may contain incidental fluids. Valleylab provides the optional E3620 Fluid Canister Ring and E3680 Fluid Canister Kit for evacuating smoke that may contain incidental fluids.

Notice

Fluids may damage the filters. When evacuating smoke and incidental fluids, always use the appropriate tubing, fluid canister, and a Valleylab E3620 Fluid Canister Ring mounted on the smoke evacuator.

Connecting multiple lengths of tubing together may cause the smoke evacuator to overheat.

Check the fluid level in the canister frequently during surgery.

Notice

If the fluid canister overfills, smoke evacuator damage will result.

1. Install a new prefilter (E3630) in the smoke evacuator, and remove the prefilter cover as described earlier in this section.
2. Test the ULPA filter as described earlier in this section.
3. Install the Valleylab fluid canister ring (E3620) on the side panel of the smoke evacuator. Place the fluid canister (E3680) in the ring.
4. Connect the tubing and applicable adapter to the prefilter and fluid canister, as shown in Figure 3-12.
5. Check the smoke evacuator before use, as described earlier in this section.

Figure 3-12.
Connecting tubing to the fluid
canister—open procedure

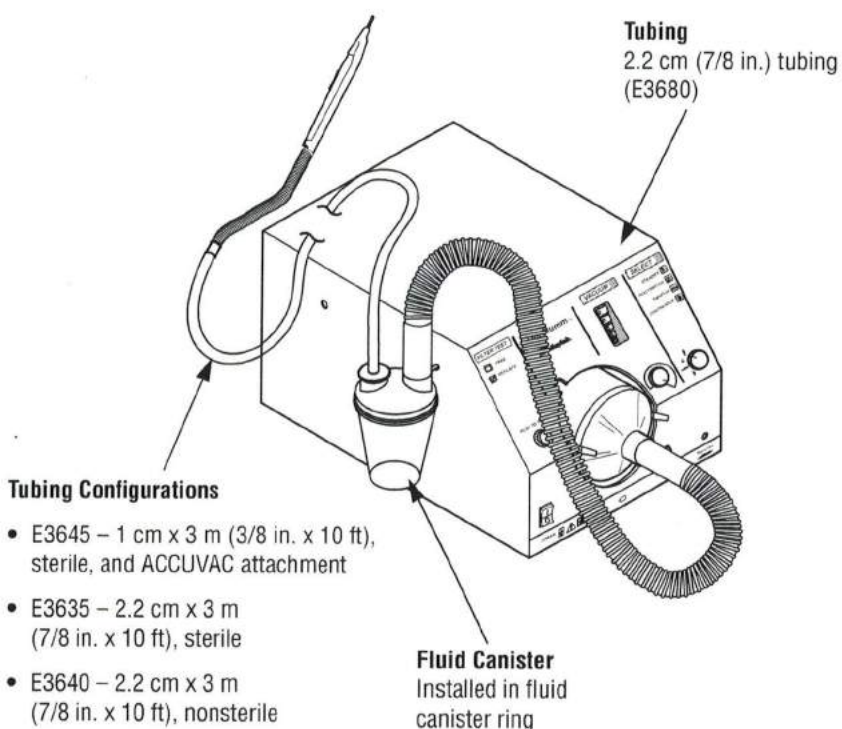



During Surgery

This section covers the following topics:

- Minimizing airflow noise
- Changing and adjusting airflow
- Checking the fluid canister
- Checking the tubing
- Checking the prefilter
- Checking the sponge guard.

Initiating Airflow

Warning

The smoke evacuator produces a strong vacuum. Adjust the airflow and the position of the inlet end of the wand or tubing to prevent patient injury and to prevent suction of surgical materials and surgical specimens.

If the smoke evacuator is activated while the airflow is set to a high speed, it may produce a sudden, strong suction action. Check the airflow setting before activating the smoke evacuator to prevent patient injury and to prevent suction of surgical materials and surgical specimens.

Caution

To maximize patient safety, the tubing or wand should not come in direct contact with tissue. Otherwise, patient injury may result.

1. Verify that all tubing is connected and that the prefilter sits firmly on top of the ULPA filter. Make sure the plastic cover is removed from the prefilter.
2. Press the power switch on the front panel to turn on the smoke evacuator.

Minimizing Noise

The higher the power setting, the greater the noise. Minimize noise by using a lower power setting. Effectiveness of a lower power setting can be maximized by using a larger diameter tubing and/or positioning the tubing closer to the source of smoke.

Variables that Affect Airflow

The following factors may affect airflow:

- Diameter of the tubing—with larger diameter tubing, airflow improves
- Airflow settings.

Changing the Airflow

You can change the airflow while the smoke evacuator is in use.

1. To change the airflow, turn the Vacuum Flow Selector on the control panel.
2. Verify that the indicator illuminates for the speed setting you selected.

Temporarily Turning Off the Airflow

To temporarily turn off the airflow, place the smoke evacuator in standby mode. When the smoke evacuator is in the standby mode:

- The standby indicator illuminates.
- There is no airflow.
- The smoke evacuator retains the previous power setting.

Periodic Checks

During surgery periodically check the accessories described below.

Fluid Canister

If you are evacuating smoke that contains incidental fluids, periodically check the level of fluid in the canister.

Notice

If the fluid canister overfills, smoke evacuator damage will result.

Due to the high velocity of air when using 7/8 in. tubing, the maximum fluid level in the canister should be 600 cc.

Tubing

Check for clogged, occluded, or kinked tubing during surgery.

Prefilter

If you are evacuating incidental fluids, periodically verify that the prefilter is not saturated. A saturated prefilter reduces airflow.

Sponge Guard

Ensure the sponge guard is fully attached to the sterile tubing to prevent suction of surgical materials.

Notes



After Surgery

This section covers the following topics:

- Preparing the smoke evacuator for reuse
- Cleaning the smoke evacuator.

Preparing the OptiMumm Smoke Evacuator for Reuse

After surgery, prepare the smoke evacuator for reuse by performing the following procedures:

- Remove the prefilter, tubing, and fluid canister.
- Clean the smoke evacuator.

Caution

Do not reuse or resterilize accessories labeled “disposable” or “single use only.”

Removing the Prefilter, Tubing, and Fluid Canister

The prefilter used in the smoke evacuator removes gross particulates from surgical smoke. You must remove and discard the used prefilter, as well as the optional canister and tubing, after each surgical procedure.

Caution

The prefilter, tubing, and optional fluid canister capture potentially hazardous particles. When removed, handle as you would any biohazardous material. Dispose of these items with other operative waste materials according to the procedures for your institution.

1. Turn the Mode Selector to standby.
2. Press the power switch on the front panel to turn off the smoke evacuator.
3. Disconnect the tubing from the fluid canister, if applicable.

4. If you used a fluid canister, remove the canister, as shown in Figure 5-1.
 - a. Cover all open ports. Leave the lid on the canister.
 - b. Carefully lift the canister out of the ring on the side of the smoke evacuator.
 - c. Dispose of the fluid canister with other operative waste materials according to the procedures for your institution.

Figure 5-1.
Disconnecting tubing from the fluid canister

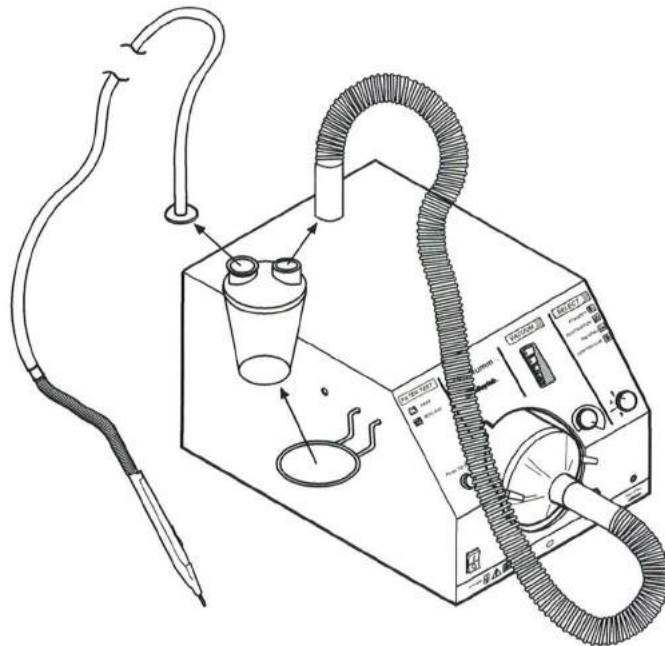
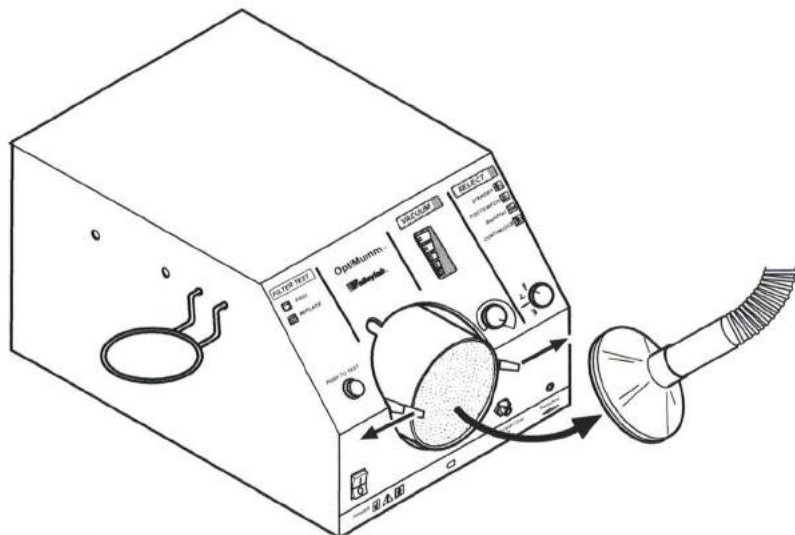

Figure 5-2.
Disconnecting the prefilter



5. With the prefilter connected to the tubing, disconnect the prefilter and tubing from the smoke evacuator, as shown in Figure 5-2.
6. Install a new prefilter and leave the cover on until the smoke evacuator is ready to use again.

Cleaning the Smoke Evacuator

Warning

Electric Shock Hazard — Always turn off and unplug the smoke evacuator before cleaning.

Notice

Do not rub, touch, or clean the smoke evacuator with alcohol or caustic, corrosive or abrasive cleaning or disinfectant compounds, solvents, or other materials that could scratch the control panel or damage the smoke evacuator.

Do not autoclave, pressure sterilize, or gas sterilize the smoke evacuator.

Keep the smoke evacuator away from liquids. Liquids that enter the smoke evacuator will damage internal components.

1. Ensure that the power switch on the front panel is off (O).
2. Disconnect the power cord from the wall receptacle.
3. Thoroughly wipe all external surfaces with a disinfectant. Follow the procedures approved by your institution or use a validated infection control procedure.
4. Ensure the smoke evacuator is completely dry before use.
5. Reconnect the power cord to the wall receptacle.



Troubleshooting

This section describes solutions to problems that may occur when operating the smoke evacuator.

If the smoke evacuator is not functioning properly, use the information in this section to help identify and correct the malfunction.

Inspecting the OptiMumm Smoke Evacuator

First, check the smoke evacuator for obvious conditions that may have caused the malfunction.

- Check the smoke evacuator for visible signs of physical damage.
- Verify that all cables and tubing are connected properly.
- Verify that the ULPA filter is properly installed.
- Check the power switch at the front of the smoke evacuator. It should be on (I). If it is off (O), turn it on.
- Test the ULPA filter to determine if it has expended its useful life.

Correcting Specific Malfunctions

If a solution to the problem is not readily apparent, use the following table to help identify and correct specific malfunctions. After you correct the malfunction, verify that the smoke evacuator is in proper working order.

Situation	Possible Cause	Recommended Action
Smoke evacuator is on but there is minimal or no vacuum or airflow at the wand or tubing.	Improperly installed prefilter.	Ensure the prefilter is properly installed on top of the ULPA filter. Reposition if necessary.
	Improperly installed ULPA filter.	Ensure the ULPA filter is properly installed. Reposition if necessary.
	Clogged tubing.	Unclog/replace tubing.
	Clogged prefilter.	Replace the prefilter.
	Clogged ULPA filter.	Replace the ULPA filter as described in Section 3.
	Obstructed or malfunctioning motor and/or blower.	Contact a Valleylab Representative for assistance.
Smoke evacuator does not adsorb odors.	The charcoal component of the ULPA filter has expired.	Replace the ULPA filter as described in Section 3.

Situation	Possible Cause	Recommended Action
Smoke evacuator does not operate.	Disconnected or faulty power cord.	Check and correct the power cord connections. Check the cord for damage.
	No power from wall receptacle (power cord is connected to wall receptacle, but Mode Indicator is not illuminated).	Check the power at the wall receptacle. Connect power cord to a functional wall receptacle.
	Power switch on the front panel is off (O).	Turn the power switch on (I).
	Circuit breaker off or needs to be reset.	Press the circuit breaker switch on the rear panel to turn the smoke evacuator on or reset it.
Footswitch does not activate smoke evacuator when Footswitch mode is selected.	Improperly connected footswitch.	Check that the footswitch is securely connected at the front of the smoke evacuator.
	Malfunctioning footswitch.	Replace the footswitch.
	Incorrect footswitch connected to the smoke evacuator.	Connect the Valleylab E3615 Footswitch to the smoke evacuator.
	ULPA/charcoal filter incorrectly installed.	Reinstall the filter as described in Section 3.
	Malfunction in the smoke evacuator.	Contact a Valleylab Representative.
Mode selector does not illuminate.	No electrical power.	Refer to electrical utility maintenance.
	Circuit breaker tripped.	Reset the breaker on the rear panel of the smoke evacuator; if trouble persists, contact a Valleylab Service Representative.
	Malfunction in the smoke evacuator.	Contact a Valleylab Representative.
Motor does not run, but Mode Selector illuminates.	ULPA/charcoal filter incorrectly installed.	Reinstall the ULPA filter as described in Section 3.
	Malfunction in smoke evacuator.	Contact a Valleylab Representative.

Situation	Possible Cause	Recommended Action
ESU remote does not activate when RapidVac mode is selected.	Generator interlink incorrectly installed.	Ensure the generator interlink is properly connected to the rear panel of the smoke evacuator and Valleylab generator.
	Electrosurgery sensor incorrectly installed.	Ensure the electrosurgery sensor is connected to the front of the smoke evacuator. <i>or</i> Check the ESU pencil lead installation on the electrosurgery sensor bobbin. <i>or</i> Ensure you are using a Valleylab pencil set at 10 W or above.
	Battery needs replacement.	Replace the 9 V battery in the electrosurgery sensor.
	ULPA/charcoal filter incorrectly installed.	Reinstall the filter as described in Section 3.



Maintenance and Repair

Refer to this section for information on:

- Routine maintenance
- The manufacturer's responsibility
- Returning the smoke evacuator for service
- Service centers.

Routine Maintenance

The OptiMumm Smoke Evacuator requires very little maintenance. Periodically, you must check the power cord and replace the ULPA filter.

Checking the Power Cord

Inspect the power cord each time you use the smoke evacuator, or at intervals recommended by your institution. Make sure the power cord is in good working condition, without exposed wires, cracks, or frayed areas.

Removing the ULPA Filter

The ULPA filter removes odorous gases and submicron particles from surgical smoke.

1. Ensure that the smoke evacuator power switch on the front panel is off (O).

Caution

The ULPA filter captures potentially hazardous particles. When removed, handle as you would any biohazardous material. Dispose of this filter with other operative waste materials according to the procedures for your institution.

Notice

If the Replace Filter indicator illuminates during the filter test, remove and replace the ULPA filter. Failure to do so may reduce airflow and compromise the efficiency of the filter.

2. Rotate the ULPA filter counterclockwise. Pull the filter out of the smoke evacuator, as shown in Figure 7-1.

Figure 7-1.
Removing the ULPA filter

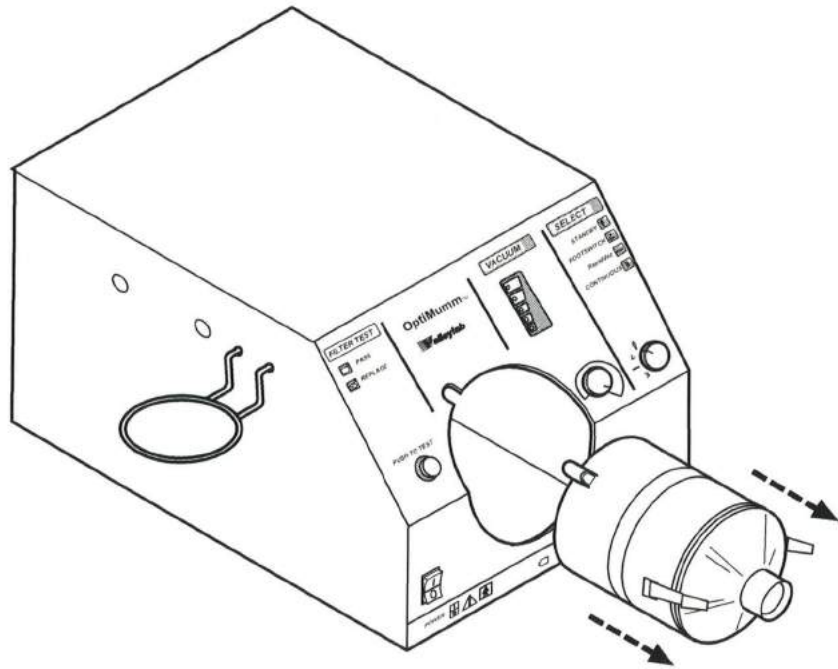

3. Dispose of the filter in the biohazard bag provided with your new ULPA filter.

Responsibility of the Manufacturer

Valleylab is responsible for the safety, reliability, and performance of the smoke evacuator only under the following circumstances:

- Installation and setup procedures in this manual are followed.
- Readjustments, modifications, or repairs to the unit are carried out by persons authorized by Valleylab.
- The electrical installation of the relevant room complies with local codes and regulatory requirements, such as UL.
- The accessories are used in accordance with the Valleylab instructions for use.

For warranty information, refer to the Warranty at the end of this guide.

Obtaining a Return Authorization Number

Notice

There are no internal user serviceable parts. For repairs, return the smoke evacuator to Valleylab.

Before you return the smoke evacuator, call the Valleylab Customer Service Department (1-800-255-8522) for a Return Authorization Number or call your Valleylab Representative for assistance.

Have the following information ready when you call:

- Hospital/clinic name/customer number
- Telephone number
- Department/address, city, state, and zip code
- Model number
- Serial number
- Description of the problem.

Returning the Smoke Evacuator for Service

Follow this procedure when returning the smoke evacuator for service. Service center information is provided below.

1. Remove the filters, tubing, and fluid container. Dispose of them with other biohazardous or surgical waste materials according to the procedures for your institution.
2. Clean the smoke evacuator. Follow the procedures approved by your institution or use a validated infection control procedure.
3. Attach a tag to the smoke evacuator that includes the Return Authorization Number and the information listed above (i.e., hospital, phone number, etc.).
4. Be sure the smoke evacuator is completely dry. Then, package the smoke evacuator in its original shipping container, if available.
5. When you get the Return Authorization Number, ship the smoke evacuator prepaid according to Valleylab's instructions.

Service Centers

Valleylab

Boulder, Colorado, 80301-3299
USA
Ph: 303-530-2300
Toll Free: 800-255-8522

Tyco Healthcare Nederland B.V.

Technical Service Center
De Beverspijken 37
5221 EE 's-Hertogenbosch
THE NETHERLANDS
Ph: 073-6312412
Fax: 073-6314540

Auto Suture France S.A.

2, rue Denis Diderot
La Clef de Saint Pierre
78990 Elancourt, FRANCE
Ph: 33 (0)1 30 79 80 40
Fax: 33 (0)1 30 79 85 73

Tyco Healthcare Deutschland

Tempelsweg 26
47918 Tonisvorst, GERMANY
Ph: 49 (0)2151 7096 92
Fax: 49 (0)2151 7096 67

For the UK, Europe, Middle East & Africa:

Tyco Healthcare UK Limited Valleylab Service Centre

Unit 1a
Corinium Industrial Estate
Raans Road
Amersham
Bucks. HP6 6YJ
UNITED KINGDOM
PH: 44 1494 789200
FAX: 44 1494 789239

Tyco Healthcare Italia SpA

Via Gaetano Crespi, 12
20134 Milano, ITALY
Ph: 39 02 212181
Fax: 39 02 2640059

Tyco Healthcare Spain S.L.

C/Fructuos Gelabert, 6 – 8 planta 8a,
08970 – Saint Joan DESPI
Barcelona
ESPANA
Ph: 34-93-680-3370
Fax: 34-93-680-2457

Tyco Healthcare Belgium B.V.

Generaal De Wittelaan 9/5
B-2800 Mechelen
BELGIUM
Ph: 32-15-298111
Fax: 32-15-217987

Tyco Healthcare Austria GmbH

Jochen Rindt Str. 37
A-1230 Vienna
AUSTRIA
Ph: 43-1-610-340
Fax: 43-1-615-3808

Tyco Healthcare PTY Ltd

Service & Technical Support
59 - 69 Halstead Street
Hurstville NSW 2220
AUSTRALIA
Ph: 61 2 9579 6066
Toll free hotline: 1800 350 702
Fax: 61 2 9585 1908

Auto Suture Japan

Regulatory Affairs Department Technical Support Section

Customer Call Center

1-2-20 Heiwajima Ota-ku Tokyo-to JAPAN
Toll Free : 0120-073-008
Ph: 03-3764-0733
Fax: 03-3764-0744

Auto Suture Company, Canada

4490 Garand Street
Ville St. Laurent
Quebec, CANADA H4R 2A2
Ph: 514-334-7602
Fax: 514-331-5983

Notes

Technical Specifications

All specifications are nominal and subject to change without notice.

Performance Characteristics

Dimensions and Weight

Width	32 cm (13 3/8 in.)
Depth	43 cm (17 in.) with cord wrap and handle
Height	25 cm (9 3/4 in.)
Weight	15 kg (34 lbs) without filters

Filters

Prefilter	captures medium and large particles > 0.3 micron; single use only
ULPA filter	0.12 micron particulate size at 99.999% efficiency; activated charcoal for gas and odor adsorption

Airflow

0–0.56 m³/min (0–20 cfm) with 2.2 cm x 3 m (7/8 in. x 10 ft) tubing with sponge guard

Airflow is measured at sea level.

Safety

115 Volt	230 Volt
Circuit breaker: 8 amps (2 pole)	Circuit breaker: 3 amps
Power cord: 3-prong hospital grade plug	Power cord: 3-prong locally approved connector
Leakage current: (50/60 Hz) Normal polarity, smoke evacuator in standby mode < 500 µA Reverse polarity, smoke evacuator in standby mode < 500 µA	Leakage current: (50/60 Hz) Normal polarity, smoke evacuator in standby mode < 1000 µA Reverse polarity, smoke evacuator in standby mode < 1000 µA

Power

115 Volt	230 Volt
Input mains voltage, (nominal): 115 Vac	Input mains voltage, (nominal): 230 Vac
Input mains voltage, full regulation range: 115 Vac ± 10%	Input mains voltage, full regulation range: 230 Vac ± 10%
Mains frequency (nominal): 60 Hz	Mains frequency (nominal): 50 Hz

Operating Parameters

Ambient temperature range	10° to 40° C (50° to 104° F)
Relative humidity	30% to 75%, noncondensing

Transport and Storage

Ambient temperature range	-34° to 65° C (-29° to 149° F)
Relative humidity	25% to 85%, noncondensing

Electromagnetic Interference

When placed on or beneath an activated Valleylab electrosurgical generator, the OptiMumm Smoke Evacuator operates without interference. The smoke evacuator minimizes electromagnetic interference to video equipment used in the operating room.

Electromagnetic Compatibility (IEC 601-1-2 and IEC 601-2-2)

The OptiMumm Smoke Evacuator complies with the appropriate IEC 601-1-2 and IEC 601-2-2 specifications regarding electromagnetic compatibility.

Description of Symbols on Unit



ATTENTION

Consult accompanying documents.



Power on or Power off.



Type B Equipment: Protection against electric shock, particularly regarding: the reliability of the protective earth connection and allowable Leakage Current.



ULPA filter installed here.



ULPA filter acceptable for use. Passes test for acceptable pressure drop through filter.



ULPA filter replacement required. Fails test for acceptable pressure drop through filter.



Standby Mode: Unit is turned on with no airflow. Unit will return to previously set airflow when switched to a different mode.



Footswitch Mode: Use footswitch for activation.



RapidVac Mode: Electrosurgery accessory cord attached to electrosurgery sensor will activate unit.



Continuous Mode: Unit runs continuously at airflow selected.

Description of Symbols on Accessories

 Sterile product. Method of sterilization is Ethylene Oxide.



Single Use Product. Do not resterilize.



Latex-Free product.



Date of product manufacture, year - month.



Date of product expiration, year - month.

Classification

Class I Equipment (IEC 601-1)

Accessible conductive parts cannot become live in the event of a basic insulation failure because of the way in which they are connected to the protective earth conductor.

Notes

Accessories

The accessories listed in this section are recommended for use with the Valleylab OptiMumm Smoke Evacuator. Accessories can be ordered through your Valleylab Sales Representative.

Product	Catalog No
Cart Bracket Set	E3610
Footswitch	E3615
Fluid Canister Ring	E3620
ULPA Filter	E3625
Prefilter	E3630
Tubing, 2.2 cm x 3 m (7/8 in. x 10 ft), sterile	E3635
Tubing, 2.2 cm x 3 m (7/8 in. x 10 ft), nonsterile	E3640
Tubing, 1 cm x 3 m (3/8 in. x 10 ft), sterile	E3645
Wand 2.2 cm (7/8 in.) diameter, sterile	E3650
Reducer Fitting, 2.2 cm to 1 cm (7/8 in. to 3/8 in.), nonsterile	E3655
Prefilter Adapter, 3.4 cm to 1 cm (1 1/3 in. to 3/8 in.) Tubing, nonsterile	E3660
Prefilter Adapter, 3.4 cm x 2.2 cm (1 1/3 in. to 7/8 in.) Tubing, nonsterile	E3665

Product	Catalog No
Prefilter Adapter, 2.2 cm to 1 cm (7/8 in. to 3/8 in.) Tubing, nonsterile	E3670
Fluid Canister kit, nonsterile	E3680
Sterile, single-use rocker switch pencil with The EDGE coated blade, ACCUVAC Smoke Evacuation Attachment and holster	E2350HS
Sterile, single-use button switch pencil with The EDGE coated blade, ACCUVAC Smoke Evacuation Attachment and holster	E2450HS
Sterile, single-use rocker switch pencil with standard blade electrode, ACCUVAC Smoke Evacuation Attachment and holster	E2515HS
Sterile, single-use button switch pencil with standard blade electrode, ACCUVAC Smoke Evacuation Attachment and holster	E2516HS
Sterile, single-use ACCUVAC Smoke Evacuation Attachment	E3590
Sterile, single-use ACCUVAC Smoke Evacuation Attachment Extender	E3595
Electrosurgery Sensor	*
Generator Interlink	*

* *Contact your Valleylab Sales Representative*

Warranty

Valleylab, a division of Tyco Healthcare Group LP, warrants the products listed below to be free from defects in material and workmanship under normal use and service for the period(s) set forth below. Valleylab's obligation under this warranty is limited to the repair or replacement, at its sole option, of any product, or part thereof, which has been returned to it or its Distributor within the applicable time period shown below after delivery of the product to the original purchaser, and which examination discloses, to Valleylab's satisfaction, that the product is defective. This warranty does not apply to any product, or part thereof, which has been repaired or altered outside Valleylab's factory in a way so as, in Valleylab's judgment, to affect its stability or reliability, or which has been subjected to misuse, neglect, or accident.

The warranty period for this Valleylab product is as follows:

OptiMumm Smoke Evacuator: Two years

THIS WARRANTY IS IN LIEU OF ALL OTHER WARRANTIES, EXPRESS OR IMPLIED, INCLUDING WITHOUT LIMITATION, THE WARRANTIES OF MERCHANTABILITY AND FITNESS FOR A PARTICULAR PURPOSE, AND OF ALL OTHER OBLIGATIONS OR LIABILITIES ON THE PART OF VALLEYLAB. Valleylab neither assumes nor authorizes any other person to assume for it any other liability in connection with the sale or use of any of Valleylab's products.

Notwithstanding any other provision herein or in any other document or communication, Valleylab's liability with respect to this agreement and products sold hereunder shall be limited to the aggregate purchase price for the goods sold by Valleylab to the customer. There are no warranties which extend beyond the terms hereof. Valleylab disclaims any liability hereunder or elsewhere in connection with the sale of this product, for indirect or consequential damages.

This warranty and the rights and obligations hereunder shall be construed under and governed by the laws of the State of Colorado, USA. The sole forum for resolving disputes arising under or relating in any way to this warranty is the District Court of the County of Boulder, State of Colorado, USA.

Valleylab, its dealers, and representatives reserve the right to make changes in equipment built and/or sold by them at any time without incurring any obligation to make the same or similar changes on equipment previously built and/or sold by them.