

## ***ELITE SERIES SURGICAL TABLES*** ***OPERATORS MANUAL***

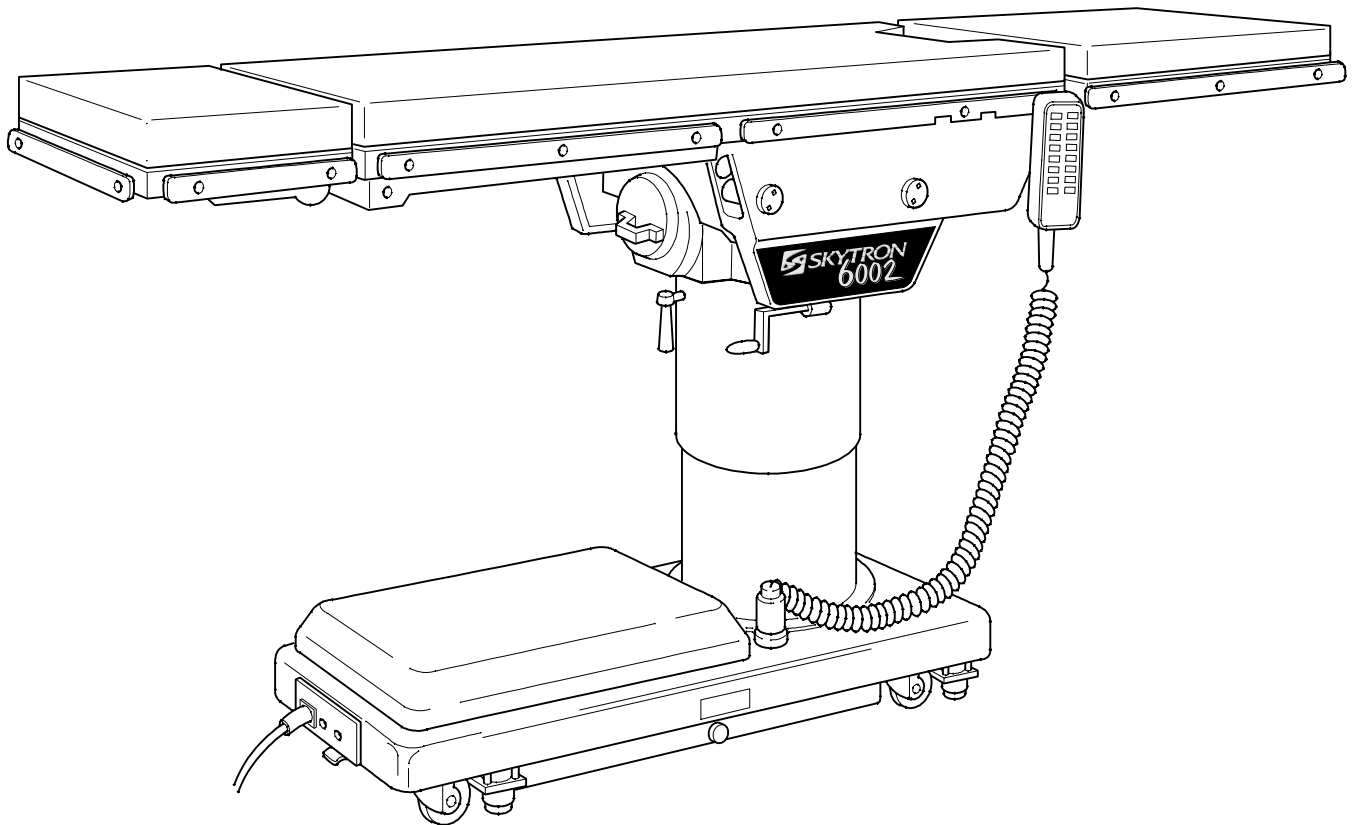

### ***MODEL 6002/6002B*** ***INCLUDING BATTERY MODELS***

# TABLE OF CONTENTS

Title	Page
6002 Series General Purpose Surgical Table Specifications .....	1
SPECIAL USER ATTENTION .....	2
SECTION I INTRODUCTION .....	5
1-1. General.....	5
1-2. Power Requirements .....	5
1-3. Pendant Control Unit .....	6
1-4. Floor Lock/Brake System.....	6
SECTION II BATTERY TABLE CONTROLS.....	7
2-1. Introduction .....	7
2-2. Battery Model Table, AC 120V Operation .....	7
2-3. Battery Operation .....	7
2-4. Automatic Shut-Off .....	8
2-5. Charging the Battery .....	8
2-6. Emergency Back-Up Controls .....	9
SECTION III OPERATION .....	10
3-1. Electrical Power .....	10
3-2. Positioning Functions .....	10
a. Floor Lock/Brake system .....	10
b. Trendelenburg .....	10
c. Lateral Tilt .....	11
d. Back Section .....	11
e. Elevation .....	11
f. Leg Section.....	12
g. Flex Positioning .....	12
h. Return To Level .....	12
i. Pendant Control Storage .....	13
3-3. Emergency Brake Release .....	13
3-4. Head Section .....	13
3-5. 180 Degree Table Top Rotation. ....	14
3-6. Kidney Lift.....	14
3-7. Positioning .....	15
3-8. Specialty Positioning .....	18
SECTION IV MAINTENANCE .....	20
4-1. Preventive Maintenance .....	20
4-2. Cleaning Recommendations .....	20
4-3. Service .....	21

REV 5/06

Although current at the time of publication, SKYTRON's policy of continuous development makes this manual subject to change without notice.

## 6002 Series General Purpose Surgical Table Specifications

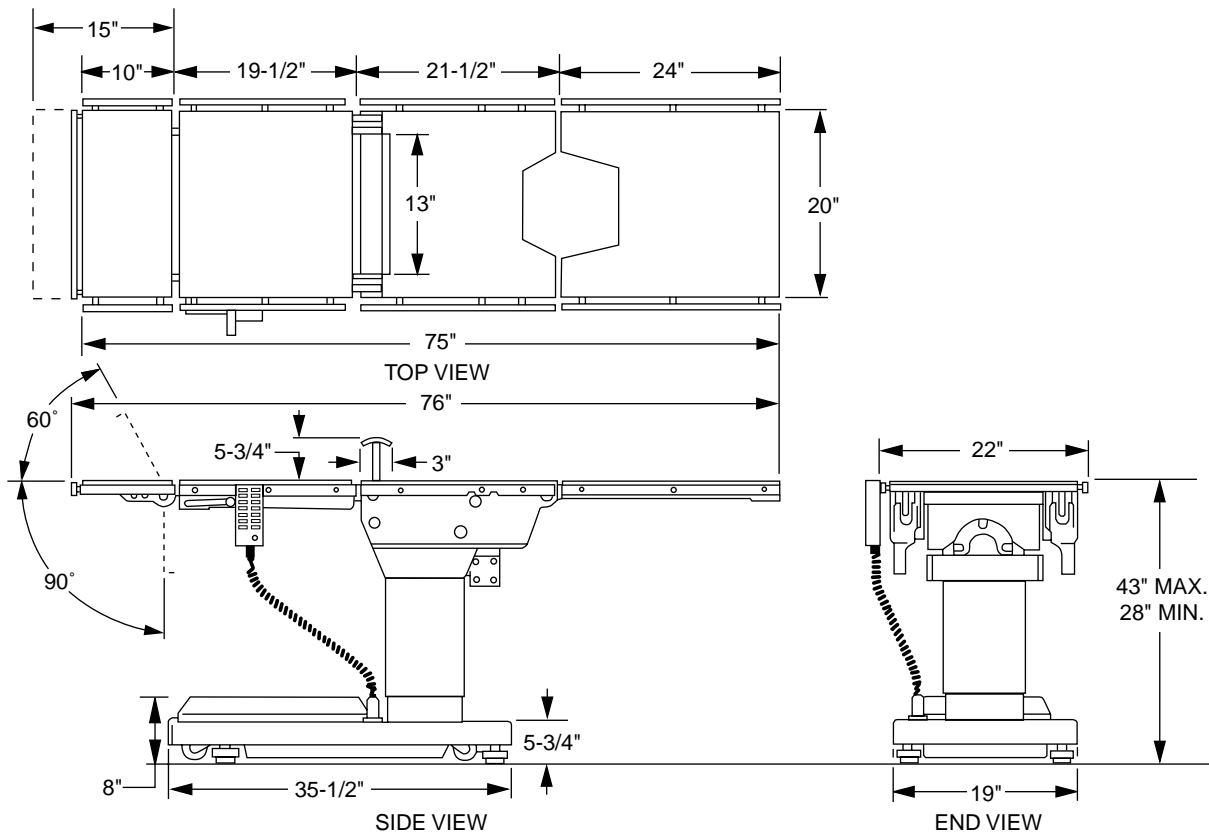

### Electrical Specifications

Power requirements	120 VAC, 60Hz, 300 Watts
Current Leakage	Less than 100 micro amps
Power Cord	15 feet w/hospital grade connector (removeable on battery model)

### ENTECLA CERTIFIED

TO UL2601-1

CAN/CSA601.1, IEC 60601-2-46

US



C

## SPECIAL USER ATTENTION

The extreme positioning capabilities of the 6002 Series Table requires special attention for possible interference points when using multiple function positioning. As with the operation of any surgical table, a certain amount of care should be exercised to position the patient safely. Although the thick pads and sheets substantially protect the patient, pinch points, located at the joints of the top section should always be considered. **BE SURE THAT THE ARMS, HANDS AND FINGERS OF THE PATIENT AND THOSE OF THE OPERATING ROOM PERSONNEL ARE CLEAR OF ALL MOVING PARTS BEFORE POSITIONING THE TABLE.** Proper restraints should always be used for patient safety.

Certain accessories such as the Uro-Drain Tray, Armboards and X-Ray top can be damaged when changing the position of the table top sections. Always look first to see if a desired movement is going to interfere with any accessories in use.

The operator has the ultimate responsibility of preventing damage to the table and surrounding equipment or possible injury to the patient or staff. In general, common sense will dictate when there is a potential hazard.

***The following precautions should be reviewed by all personnel prior to operating the table.***

***A routine Instructional Program should be implemented by the facility for proper usage instructions for all personnel that may operate this table.***



### WARNING



Indicates a possibility of personal injury.



### CAUTION



Indicates a possibility of damage to equipment.

### NOTE

Indicates important facts or helpful hints.



### WARNING



Risk of electrical shock. Make sure power cord is disconnected prior to accessing fuses.

### NOTE

Activating any function button will activate the brake system. Using the TABLE UP function to set the brakes provides a visual assurance that the brakes are locked. As the brake cylinders are extending, the entire table will move slightly. When the table top begins to elevate, the brakes are fully locked.



### WARNING



DO NOT unlock brakes when a patient is on the table. An uneven patient weight load may cause instability.

•Never operate the table without ensuring that the brakes are set.



### WARNING



Possible explosion hazard exists if table is used in the presence of FLAMMABLE ANESTHETICS.

### NOTE

The table will operate correctly on battery power with the power cord connected to a wall outlet or disconnected.

### NOTE

Battery Operation must be turned OFF at the pendant control. It can not be turned Off using the main power switch.

### NOTE

If the table is stored for a period greater than 6 months, the batteries should be removed and stored in a dry, clean condition at a storage temperature of 68° F (20° C). Batteries should be recharged every 6 months of product storage.

## SPECIAL USER ATTENTION

### NOTE

When the amber light starts to blink (indicating low power in battery) the table will operate for approximately 5 continuous minutes, typically long enough to use the table for the rest of the day.

### NOTE

The charging system operates ONLY when the table is in AC120V operation mode.

### NOTE

The table can be operated on 120VAC power while the battery is being re-charged. The green AC 120V indicator light (on the pendant control) will illuminate confirming 120VAC operation.

### NOTE

The emergency back-up control switches will function when the table is operating on 120VAC power, battery power, or turned off.

### NOTE

The main power switch can be placed in the OFF position to completely deactivate all table functions if required during certain procedures or in case of emergency.

### NOTE

With an evenly distributed patient weight load, all table positioning functions will operate smoothly and quietly with a patient weight of up to 600 pounds. Refer to section 3-8 for specialty positioning.



### WARNING



DO NOT unlock brakes when a patient is on the table. An uneven patient weight load may cause instability.



### WARNING



To maximize patient safety, utilize proper restraint methods during extreme Trendelenburg positioning.



### WARNING



To maximize patient safety, utilize proper restraint methods during extreme lateral tilt positioning.



### CAUTION



To prevent damage to the kidney lift, make sure the kidney lift is completely down before raising the back section.



### WARNING



The Leg section may hit the table base or the floor if both the leg and elevation systems are placed in their full down position.

### NOTE

Elevation and brake system functions are not affected by the return to level function.

### NOTE

The Emergency Brake Release Valve must be closed and tightened (clockwise) before activating any function.

•If the Emergency Brake Release Valve has been operated, the UNLOCK button on the pendant control will have to be pressed before brakes will lock again.

### NOTE

Normal table top position is with the head (and back) section over the power cord end of the base.



### WARNING



Always lock the table top in position after rotation. DO NOT rotate the top with an unevenly distributed patient weight load as instability may result.

## SPECIAL USER ATTENTION



### WARNING



•Make sure the TOP ROTATION LOCK HANDLE is tightened and the brakes are set before transferring the patient.

•Exercise caution with the table top rotated 90° to the base since an improperly distributed patient load may cause the table to be tipped over.



### CAUTION



To prevent damage to the kidney lift, make sure the kidney lift is completely down before raising the back section. See figure 3-18.



### WARNING



Consult manufacturer's instructions when using high frequency surgical equipment, cardiac defibrillator and cardiac defibrillator monitors.



### WARNING



When an antistatic pathway is required, the table has to be used on an antistatic floor.



### WARNING



The antistatic properties of the table are dependent on the use of the original pad set which was furnished with the table or an alternate approved replacement.



### WARNING



Certain accessories may limit weight capacities, check with your SKYTRON representative.



### WARNING



To ensure patient safety, certain positioning techniques and some accessories should NOT be used when a patient's weight **exceeds 500 pounds**.

### NOTE

Always follow current AORN Journal Guidelines to ensure proper cleaning and disinfection procedure.



### CAUTION



Caution should be taken when cleaning the table to prevent excessive fluid entry into electrical connectors.



### WARNING



Always follow OSHA blood-borne pathogens standards for protective clothing, including gloves, masks and eye protection when cleaning the surgical table.



### CAUTION



Thoroughly read and follow the manufacturer's directions for all cleaning fluids. DO NOT use cleaners containing phenolics.



### CAUTION



When using spray cleaners DO NOT spray fluids directly into electrical receptacles or micro switches.



### CAUTION



Before replacing pads on the table, make sure the pads and all mating surfaces are completely dry. Moisture trapped between the pads and mating surfaces may cause distortion of table tops.

## SECTION I INTRODUCTION

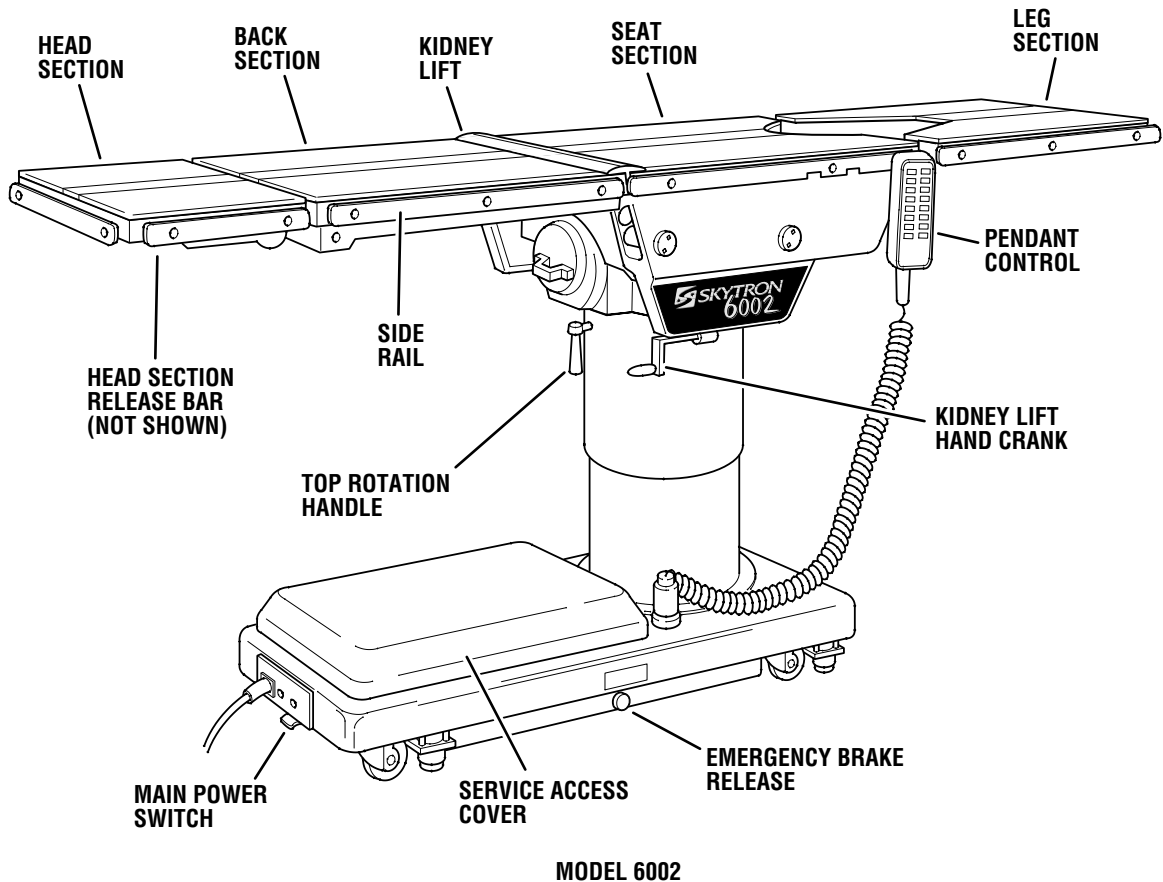

Figure 1-1. Elite 6002

### 1-1. General

SKYTRON's Elite 6002 Series Surgical Tables are electro-hydraulically operated, general purpose surgical tables. See figure 1-1.

The electro-hydraulic positioning functions operated by the hand-held, push button, pendant control unit are: trendelenburg, lateral tilt, back section, elevation, leg section, flex/reflex, return to level, and the floor lock/brake system.

Manual controls are provided for head section positioning, table top rotation, emergency brake release and kidney lift.

### 1-2. Power Requirements

The Elite 6002 Series Surgical Tables require a 120VAC, 60 Hz electrical power supply. The table is equipped with a 15 foot long power cord with a standard three prong, hospital grade plug. The electrical protection fuses are located behind a cover plate in the electrical enclosure on the front

edge of the base. See figure 1-2. The main power ON/OFF switch is located on the electrical enclosure.



### WARNING



Risk of electrical shock. Make sure power cord is disconnected prior to accessing fuses.

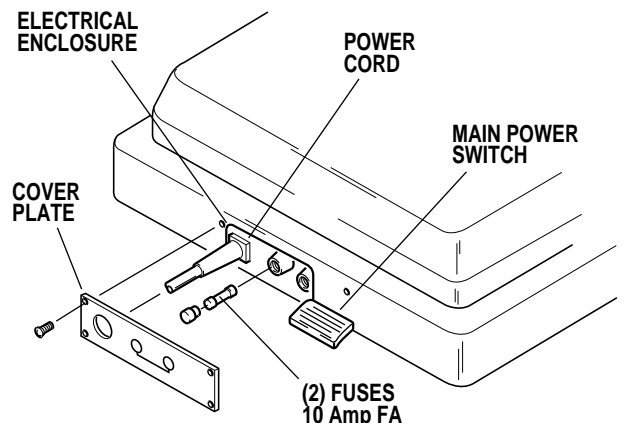

Figure 1-2. Power Switch and Fuse Location

### 1-3. Pendant Control Unit

The hand-held pendant control unit (figure 1-3) has a non-slip rubber cover which assures a positive grip during use. A spring clip hanger is located on the back of the control for storage. When the Pendant Control is not in use, it should be stored on a convenient side or end rail. A bracket is located under the table top for storage of the Pendant Control when the table is not in use and during cleaning. See figure 1-4.

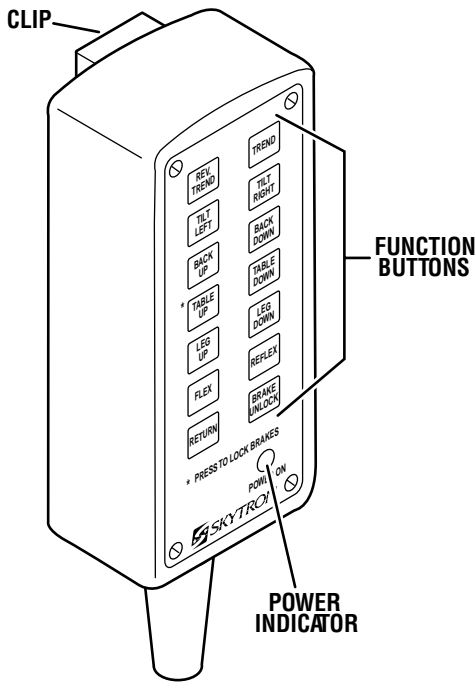

Figure 1-3. Pendant Control Unit

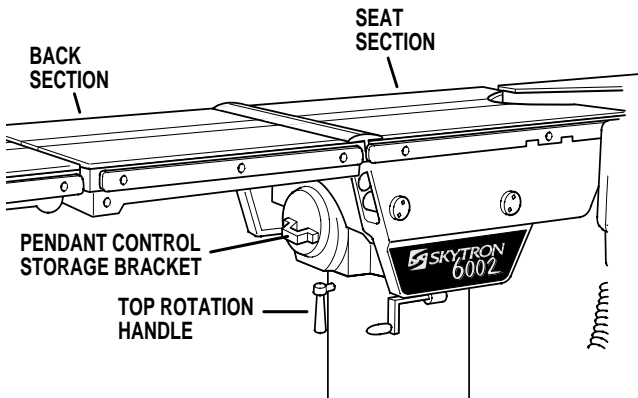

Figure 1-4. Pendant Control Storage Bracket

The function push buttons are identified with abbreviated descriptions for all functions. See figure 1-5. The Trendelenburg and table up buttons are red, the remaining buttons are all black.

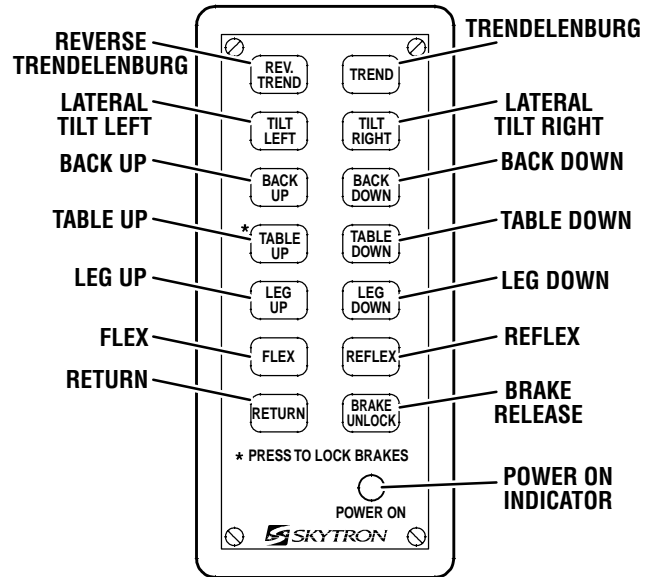

Figure 1-5. Function Push Buttons

### 1-4. Floor Lock/Brake System

The floor lock/brake system consists of four self-leveling, hydraulic brake cylinders which raise and support the table base off from the casters. Press the TABLE UP button on the pendant control to set the table's brakes. An electronic timer will activate the brake system until the brakes are completely set, approximately 8-10 seconds.

#### NOTE

Activating any function button will activate the brake system. Using the TABLE UP function to set the brakes provides a visual assurance that the brakes are locked. As the brake cylinders are extending, the entire table will move slightly. When the table top begins to elevate, the brakes are fully locked.

To unlock the brakes, press the BRAKE UNLOCK button and release. The brakes will retract automatically in approximately 7-8 seconds.



#### WARNING

DO NOT unlock brakes when a patient is on the table. An uneven patient weight load may cause instability.



- Never operate the table without ensuring that the brakes are set.





## SECTION II BATTERY TABLE CONTROLS

### 2-1. Introduction

The operation of the 6002B, Battery Model table is identical to the line powered models except for the functions required to operate on battery power. The following section explains the differences for the battery powered models.

 **WARNING**   
Prior to operating the table, observe all table caution labels and review the SPECIAL USER ATTENTION section in the front of this manual.

 **WARNING**   
Possible explosion hazard exists if table is used in the presence of FLAMMABLE ANESTHETICS.

### 2-2. Battery Model Table, AC 120V Operation

The battery model tables will operate on either 120 VAC or battery power. Use the following procedures to operate the table on 120 VAC power.

a. Be sure the power cord is plugged into a properly grounded, Hospital Grade, 120VAC outlet. Make sure the power cord is routed to the outlet to prevent it from being in the way of operating personnel.

b. Activate the POWER SWITCH located on the electrical panel. See figure 2-1. The green AC120V, Power-On indicator light located in the lower right corner of the pendant control will illuminate. See figure 2-2.

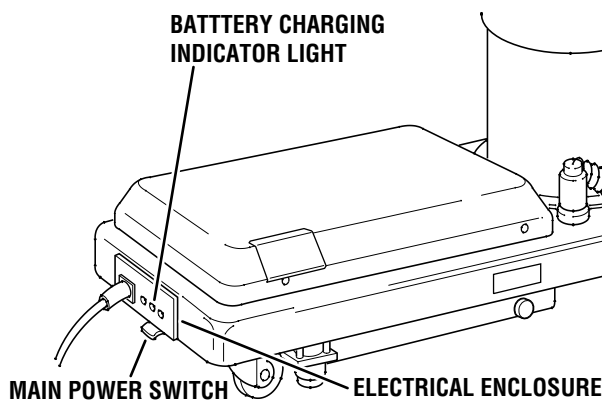

Figure 2-1. Main Power Switch

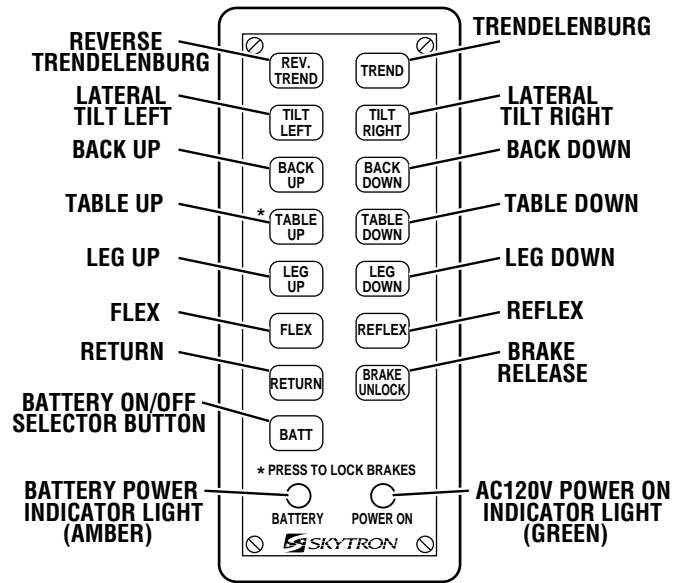

Figure 2-2. Pendant Control

### 2-3. Battery Operation

a. Make sure the green, AC 120V, Power-On indicator light, on the hand-held pendant control, is OFF. See figure 2-2. If the indicator light is ON, depress the main power ON/OFF switch, located on the electrical enclosure to turn AC120V operation OFF.

#### NOTE

The table will operate correctly on battery power with the power cord connected to a wall outlet or disconnected.

b. Press the BATT button on the hand-held pendant control. The amber BATTERY indicator light, located in the lower left corner of the pendant control, will illuminate. This confirms that the table is now being operated with battery power.

c. The table is now ready to operate on battery power. Refer to Section 3 for operation.

d. To extend the battery charge life, turn the BATTERY power OFF with the pendant control when the table is not going to be used.

#### NOTE

Battery Operation must be turned OFF at the pendant control. It can not be turned Off using the main power switch.

## 2-4. Automatic Shut-Off

a. To prevent unnecessary discharge of the battery, a timer is built into the battery circuit. This timer will automatically shut the battery power OFF after 3-4 hours of table inactivity.

b. To turn the table "ON" again, simply press the BATT button on the pendant control and the amber indicator light will illuminate. Select any control button to operate the table.

## 2-5. Charging the Battery

Batteries should be charged:

- When the table is placed into initial service
- As indicated by red indicator light blinking
- Every week in normal service

### NOTE

If the table is stored for a period greater than 6 months, the batteries should be removed and stored in a dry, clean condition at a storage temperature of 68° F (20° C). Batteries should be recharged every 6 months of product storage.

a. If the battery needs to be charged when operating the table on battery power, the amber indicator light on the pendant control will begin to blink. At this time the battery needs to be recharged.

### NOTE

When the amber light starts to blink (indicating low power in battery) the table will operate for approximately 5 continuous minutes, typically long enough to use the table for the rest of the day.

### NOTE

The charging system operates ONLY when the table is in AC120V operation mode.

b. To recharge the battery simply plug the power cord into a 120VAC wall outlet, if not already plugged in. Turn the main power ON/OFF switch ON by depressing it. The green battery charging light, located next to the power cord, will illuminate.

c. A full battery charge will last approximately 2 weeks under normal operating conditions. However, it is recommended to charge the batteries at the end of each week to establish a normal routine protocol. Lead acid batteries last longer if they are not permitted to fully discharge. The table features (2) 12 volt, sealed, lead acid batteries which require no manual maintenance. Lead acid gel batteries, under a proper charging program, feature an approximate normal life of 4 years.

### NOTE

The table can be operated on 120VAC power while the battery is being recharged. The green AC 120V indicator light (on the pendant control) will illuminate confirming 120VAC operation.

## 2-6. Emergency Back-up Controls

a. The emergency back-up control switches are located under the access door on the service access cover in the table base. See figure 2-3.

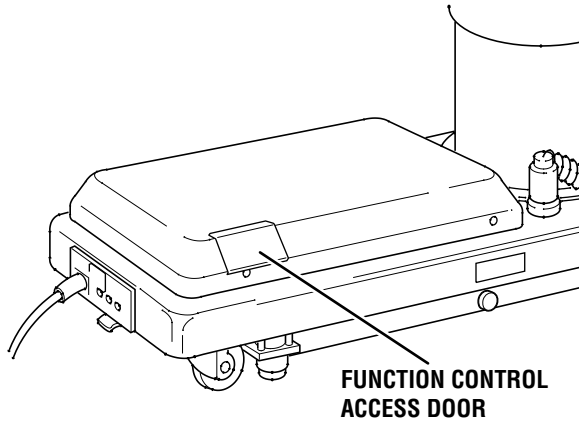

Figure 2-3. Emergency Controls Location

b. In the event of either a power failure or a problem with the hand-held pendant control, the table can be operated using the emergency back-up switches. Simply push the desired emergency switch in the appropriate direction to operate the table functions. See figure 2-4. These switches are spring-loaded so they return to the neutral or center position when released.

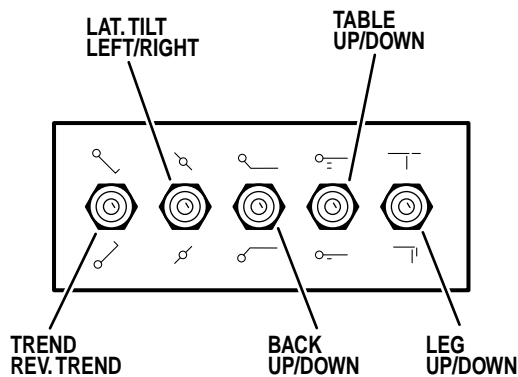

Figure 2-4. Emergency Back-Up Controls

### NOTE

The emergency back-up control switches will function when the table is operating on 120VAC power, battery power, or turned off.

## SECTION III OPERATION

### 3-1. Electrical Power

a. Check to be sure the power cord is plugged into a properly grounded, Hospital Grade, 120VAC outlet. Make sure the power cord is routed so as to prevent it from being in the way of the operating personnel.

b. Depress “Main Power ON/OFF” switch on the electrical enclosure. See figure 3-1. The green POWER ON indicator light on the pendant control should now be illuminated.

#### NOTE

The main power switch can be placed in the OFF position to completely deactivate all table functions if required during certain procedures or in case of emergency.

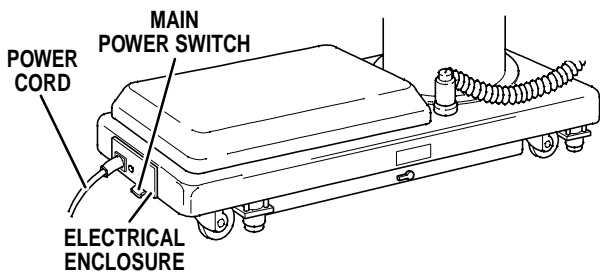

Figure 3-1. Main Power Switch

### 3-2. Positioning Functions

The hand-held pendant control (figure 3-2) activates the following table functions:

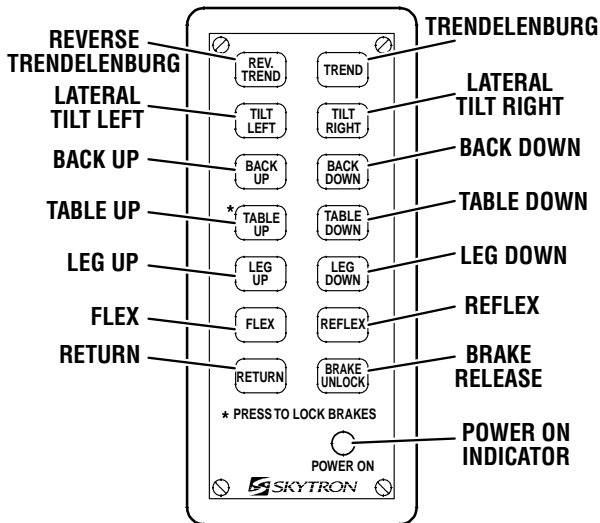

Figure 3-2. Pendant Control Unit

#### NOTE

With an evenly distributed patient weight load, all table positioning functions will operate smoothly and quietly with a patient weight of up to 600 pounds. Refer to section 3-8 for speciality positioning.

a. **Floor Lock/Brake System.** To activate the brakes without affecting table positioning, press the TABLE UP button. See figure 3-3. The elevation cylinder will not function until the brakes are completely extended.

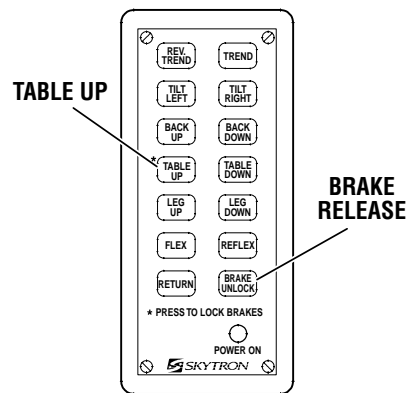

Figure 3-3. Brake System Activation

Press the BRAKE UNLOCK button on the pendant control to release the four self-leveling brake feet in order to move the table. See figure 3-3. The brake delay circuit automatically retracts the brake system with just one press of the BRAKE UNLOCK button. It takes approximately 7-8 seconds to totally release the system.



**WARNING**



DO NOT unlock brakes when a patient is on the table. An uneven patient weight load may cause instability.

b. **Trendelenburg.** To place the surgical table in a Trendelenburg (head down) position, press the TREND button (figure 3-4). Trendelenburg positioning of up to 30° may be obtained. To place the table in a reverse trendelenburg (head up) position, press the REV TREND button. Reverse Trendelenburg positioning of up to 30° may be obtained.



### WARNING



To maximize patient safety, utilize proper restraint methods during extreme Trendelenburg positioning.

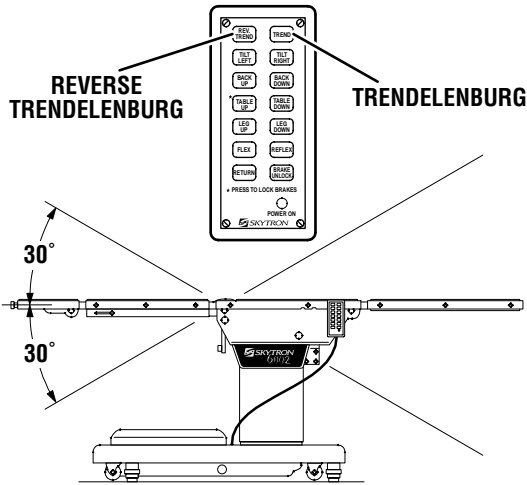

Figure 3-4. Trendelenburg Positioning

**c. Lateral Tilt.** To achieve lateral tilt right (as viewed from the head end of the table), press the TILT RIGHT button (figure 3-5). Tilt of up to 30° may be obtained. To achieve lateral tilt left, press the TILT LEFT button. Tilt of up to 30° may be obtained.



### WARNING



To maximize patient safety, utilize proper restraint methods during extreme lateral tilt positioning.

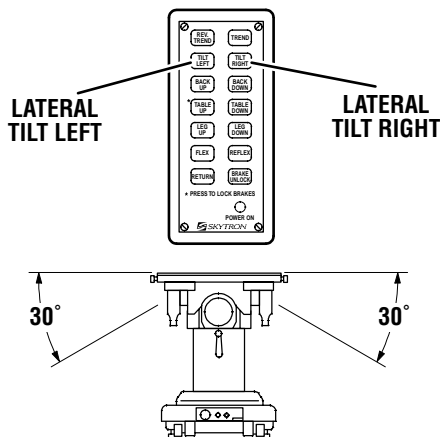

Figure 3-5. Lateral Tilt Positioning



### CAUTION



To prevent damage to the kidney lift, make sure the kidney lift is completely down before raising the back section.

**d. Back Section.** To raise the back section, press the BACK UP button (figure 3-6). The back section will raise up to 90° above horizontal. To lower the back section, press the BACK DOWN button. The back section will go down to 40° below horizontal.

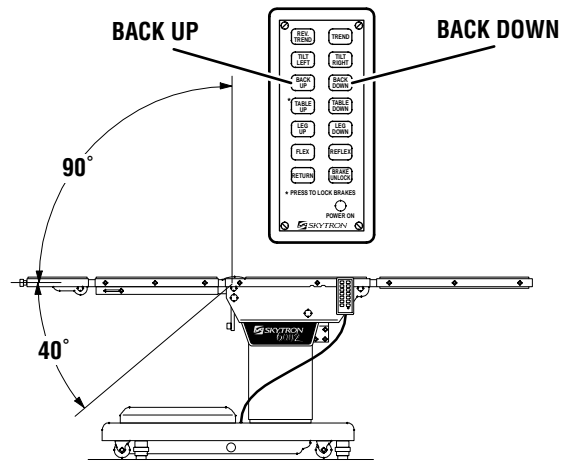

Figure 3-6. Back Section Positioning

**e. Elevation.** To raise table top, press the TABLE UP button (figure 3-7). The table will lift a patient weight of 600 pounds up to a maximum height of 43". To lower the table top, press the TABLE DOWN button. The table top will go down to a minimum height of 28".

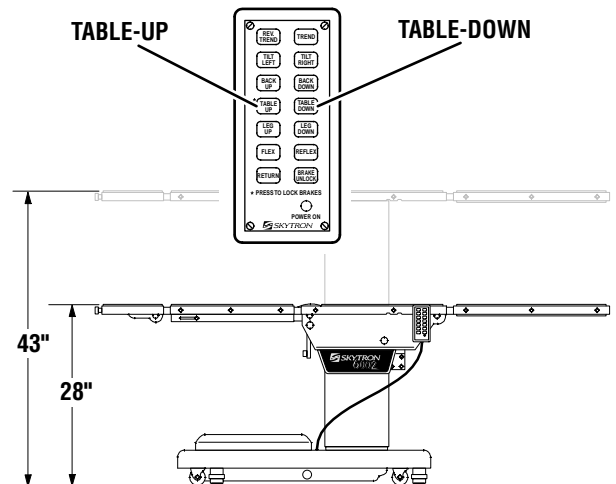
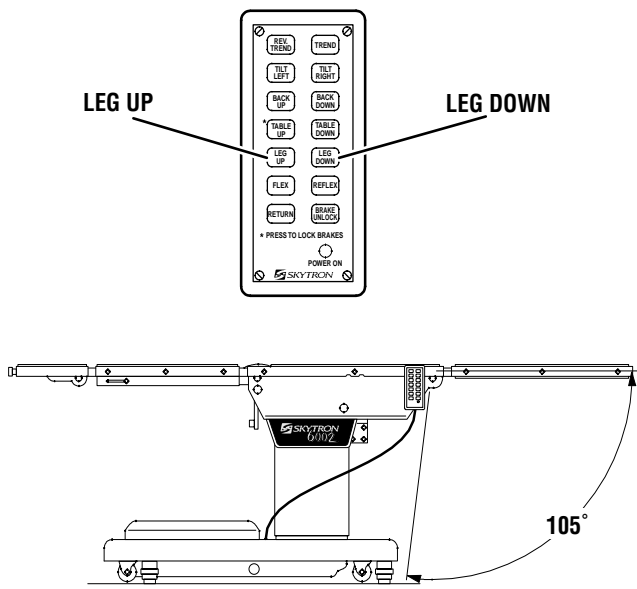

Figure 3-7. Elevation Function

**f. Leg Section.** To lower the leg section press the LEG DOWN button (figure 3-8). The leg section will go down to 105° below horizontal. To raise the leg section, press the LEG UP button. The leg section will go up to horizontal.



**Figure 3-8. Leg Section Positioning**



**WARNING**



The Leg section may hit the table base or the floor if both the leg and elevation systems are placed in their full down position.

**g. Flex Positioning.** To place the table top in a flex position from horizontal, press the FLEX button (figure 3-9). To return the table top to a horizontal position or into a reflex position, press the RETURN or REFLEX button.

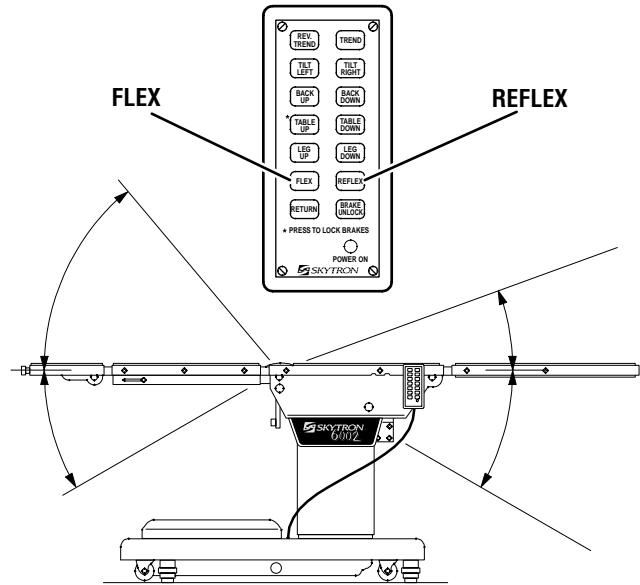
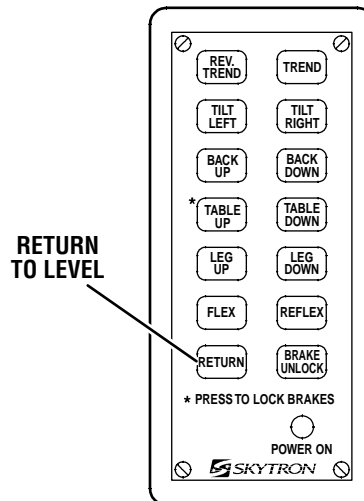

**Figure 3-9. Flex/Reflex Positioning**

**h. Return To Level.** To return the table top to a level position, press the RETURN button (figure 3-10).

**NOTE**

Elevation and brake system functions are not affected by the return to level function.



**Figure 3-10. Return To Level**

**i. Pendant Control Storage.** When the Pendant Control is not in use, it should be stored on a convenient side or end rail. A bracket is located under the table top for storage of the Pendant Control when the table is not in use and during cleaning. See figure 3-11.

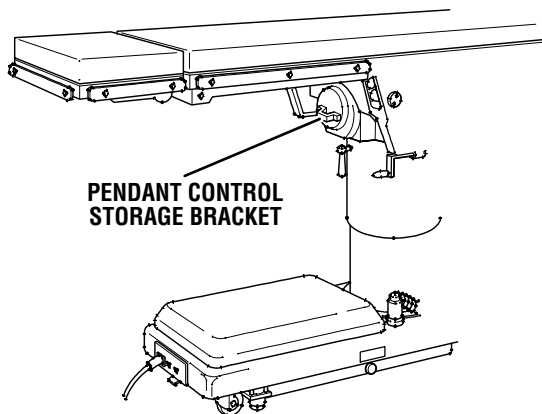

**Figure 3-11. Pendant Control Storage Bracket**

### 3-3. Emergency Brake Release.

In case of a power failure or an electrical problem within the table, the emergency brake release system can be used to move the table. The control lever for this function is located on the side of the table base and is identified by an EMERGENCY BRAKE RELEASE label. Turn the lever counter-clockwise to release the brakes. See figure 3-12.

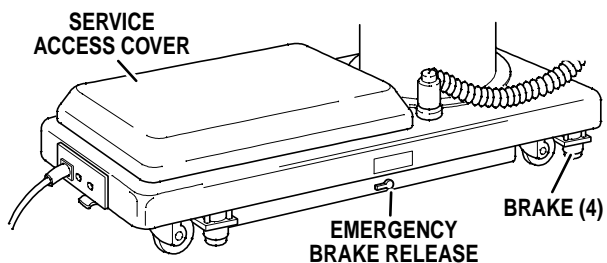

**Figure 3-12. Emergency Brake Release**

**NOTE**

The Emergency Brake Release Valve must be closed and tightened (clockwise) before activating any function.

- If the Emergency Brake Release Valve has been operated, the UNLOCK button on the pendant control will have to be pressed before brakes will lock again.

### 3-4. Head Section

**a.** A quick release positioning bar located under and to the front of the head section (figure 3-13) is used to raise or lower the head section. Pull the release bar toward the head end to allow the section to pivot up or down. Positioning from 75° above horizontal to 90° below horizontal in 15° increments is available. Release the bar to lock the head section in position.

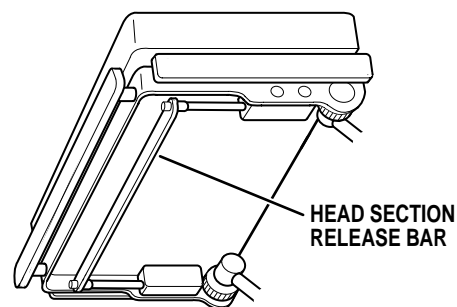

**Figure 3-13. Head Section Adjustment**

**b.** By loosening two locking knobs beneath the back section, an additional 5" of longitudinal adjustment can be achieved. If desired, the head section may be removed by loosening the locking knobs and pulling it straight out of the back section. 6002 Series Tables have the capability of attaching the head section to the leg section for use as a foot extension ONLY. Do Not reverse the patient on the table without first consulting with SKYTRON. Two locking knobs are located on the inside of the leg section for securing the head section. See figure 3-14.

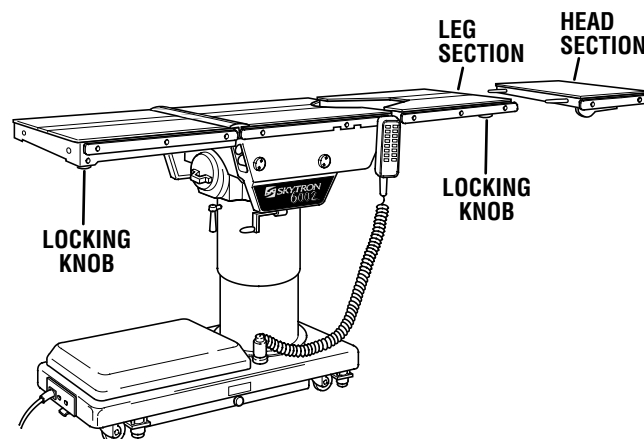

**Figure 3-14. Repositioning Head Section**

### 3-5. 180 Degree Table Top Rotation.

#### NOTE

Normal table top position is with the head (and back) section over the power cord end of the base.

a. The table top can be horizontally rotated 180° without having to rotate the entire table. To rotate the top, turn the TOP ROTATION LOCK HANDLE counterclockwise (figure 3-15), grasp the table by the head end and rotate the top 180° counterclockwise. Lock the top in position by tightening the TOP ROTATION LOCK HANDLE clockwise.



#### WARNING



Always lock the table top in position after rotation. DO NOT rotate the top with an unevenly distributed patient weight load as instability may result.

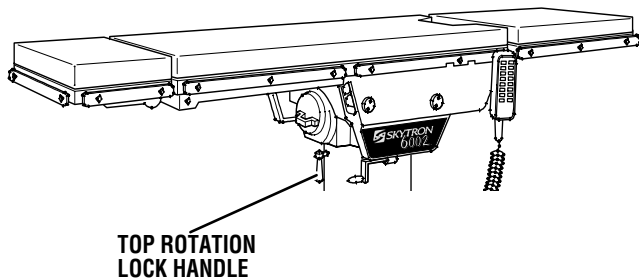

Figure 3-15. 180 Degree Top Rotation

b. The use of the optional support rod allows the table top to be rotated 90° from the base. See figure 3-16.



#### WARNING



- Make sure the TOP ROTATION LOCK HANDLE is tightened and the brakes are set before transferring the patient.

- Exercise caution with the table top rotated 90° to the base since an improperly distributed patient load may cause the table to be tipped over.

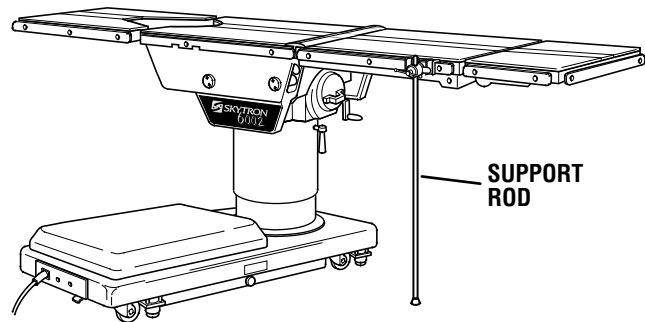

Figure 3-16. 90 Degree Top Rotation

### 3-6. Kidney Lift

a. The built-in kidney lift is operated by a manual hand crank system and allows 5-3/4 inches of lift. See figure 3-17. The hand crank is stored in a bracket on the lower right hand side frame (as viewed from the head end of the table).

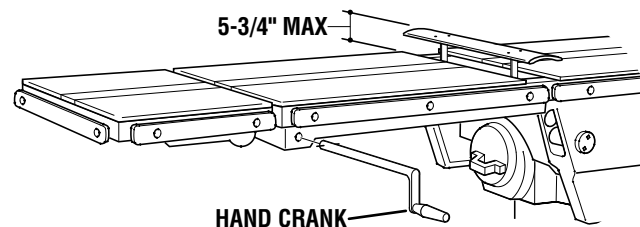

Figure 3-17. Optional Kidney Lift



b. To operate, connect the handle to the drive mechanism on right side of the back section. Rotate the handle clockwise to raise the lift and counterclockwise to lower it.



To prevent damage to the kidney lift, make sure the kidney lift is completely down before raising the back section. See figure 3-18.

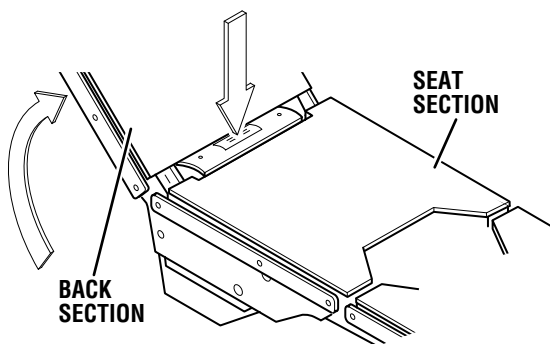

**Figure 3-18.**



Consult manufacturer's instructions when using high frequency surgical equipment, cardiac defibrillator and cardiac defibrillator monitors.



When an antistatic pathway is required, the table has to be used on an antistatic floor.



The antistatic properties of the table are dependent on the use of the original pad set which was furnished with the table or an alternate approved replacement.

### 3-7. Positioning

The use of certain optional accessories available from SKYTRON further extend the positioning capabilities of the 6002 Series Tables. Refer to the following "Positioning Guidelines" or contact your SKYTRON representative for further details.



Certain accessories may limit weight capacities. check with your SKYTRON representative.

Refer to paragraph 3-8 for specialty accessories and positioning for patients **over 500 lbs.**

## 6002 Series Patient Positioning Guidelines

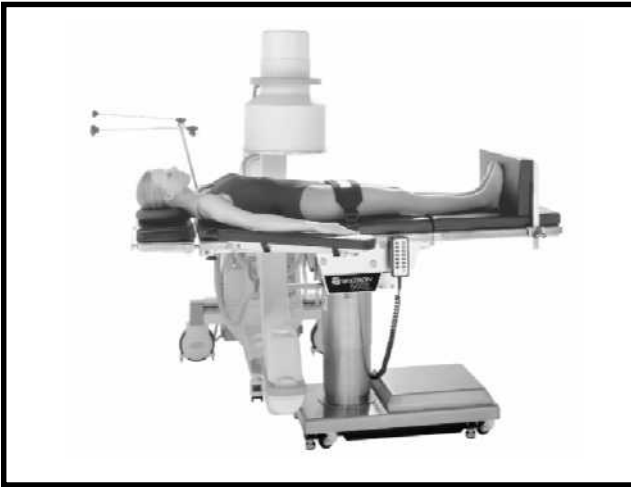

**Upper Body Imaging** Accessories: "L" Type Anesthesia Screen, Standard Armboard and 2" Pad, Snap Strap, 10" foot Extension and 2" Pad.

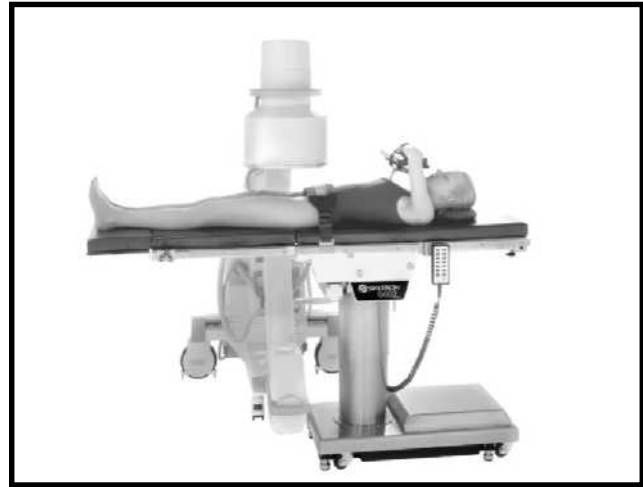

**Lower Body Imaging** Accessories: Multi-Task Armboard with Pad, Snap Strap, 10" Foot Extension and 2" Pad.



**Lap Nissen** Accessories: Multi-Task Armboard with Pad, Nissen Strap, Levitator Stirrups.

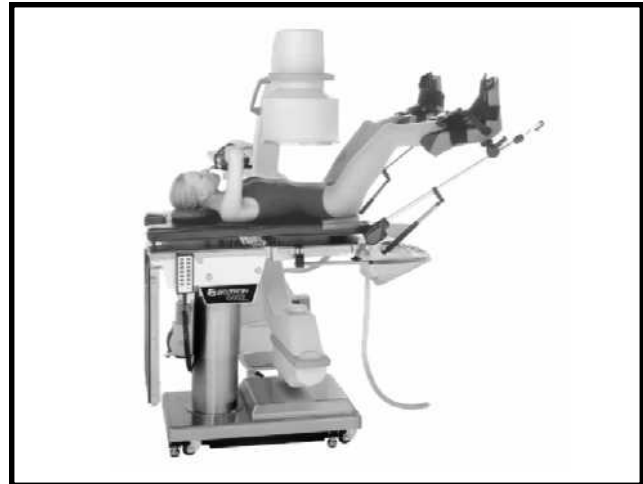

**Ureteroscopy/Cysto** Accessories: Multi-Task Armboard with Pad, Levitator Stirrups, Uro Catcher, Uro Catcher Pouch.



**OB/GYN** Accessories: Raised Armboard, Ankl-Lock Stirrups, 10" Foot Extension.



**Ophthalmic/ENT** Accessories: Standard Armboard and 2" Sof-Pad, 10" Foot Extension and 2" Pad.

## 6002 Series Patient Positioning Guidelines



**Thoracic/Kidney** Accessories: Standard Armboard, and 2" Pad, Multi-Task Armboard with Pad, Snap Strap, Chest & Waist Supports, 10" Foot Extension and 2" Pad.



**Neurosurgery** Accessories: Multi-Task Armboard with Pad, Snap Strap, 10" Foot Extension, and 2" Pad.



**Shoulder** Accessories: Shoulder Arthroscopy Positioner, Lateral Brace, Multi-Task Armboard with Pad, Restraint Strap, 10" Foot Extension, and 2" Pad.



**Hip** Accessories: Multi-Task Armboard with Pad, Standard Armboard and 2" Pad, Restraint Strap, Chest & Waist Supports.



**Lumbar** Accessories: Multi-Task Armboard with Pad, Safety Strap.



**Vascular/Orthopedic** Accessories: Multi-Task Armboard with Pad, Universal Split Leg with 2" Pad (pr).

### 3-8. Specialty Positioning



#### WARNING



To ensure patient safety, certain positioning techniques and some accessories should NOT be used when a patient's weight **exceeds 500 pounds**.

#### DO

- Do use patient restraints on all patients.
- Do use "Positioning Guidelines" ONLY for patients under 500 pounds.
- Do use table side extensions (3-060-02) to widen table to 27" when necessary.
- Do use Sof-Pads (1-010-22-5) or PHD pads (1-010-22-PHD) whenever possible but especially if patient weight is over 500 pounds.
- Do use Levitator Stirrups (4-090-03-1) or knee crutches (4-010-01-1).
- Do use 105" restraint strap (6-010-41-X)

#### DON'T

**This list is not limited to the items listed below**

- Don't use normal positioning techniques with patients over 500 pounds
- Don't reverse the patient on the table if patient weight is over 500 pounds
- Don't use the following accessories if patient weight is over 500 pounds:
  - Transfer Board
  - 18" Knee rest
  - Lithotomy Stirrups
  - Ankle-Lock Lithotomy Stirrups
  - Kidney Horns
  - Shoulder Arthroscopy Positioner
  - Prone Positioning Frame

# MODEL 6002 Positioning for Patient Weight Exceeding 500 Pounds

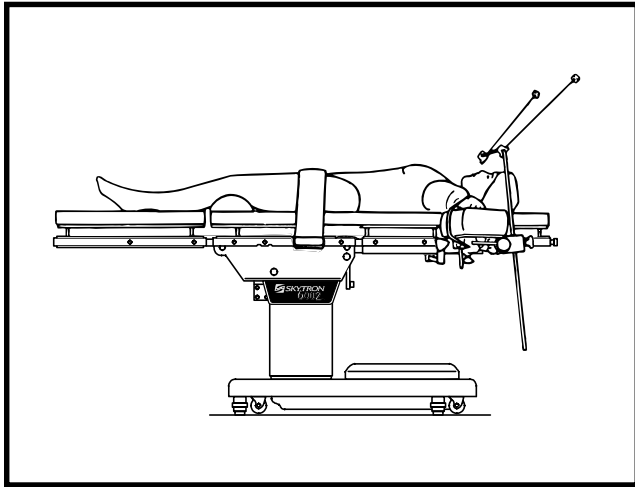

**Supine Basic Position**

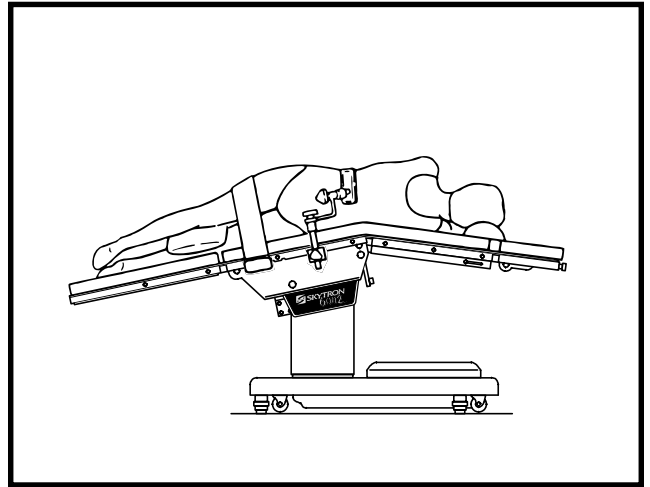

**Lateral Basic Position**

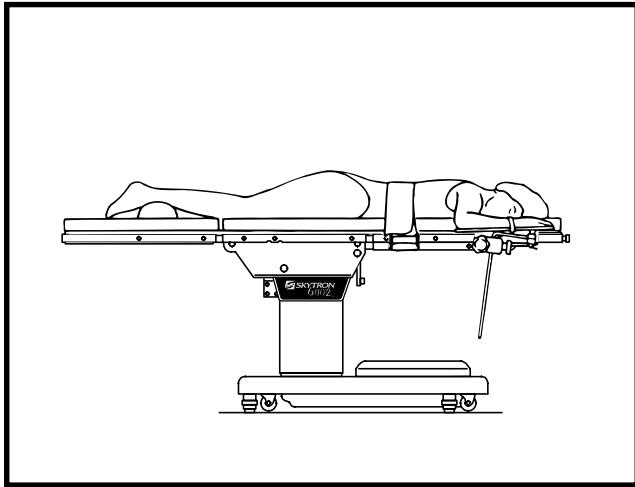

**Prone Basic Position**

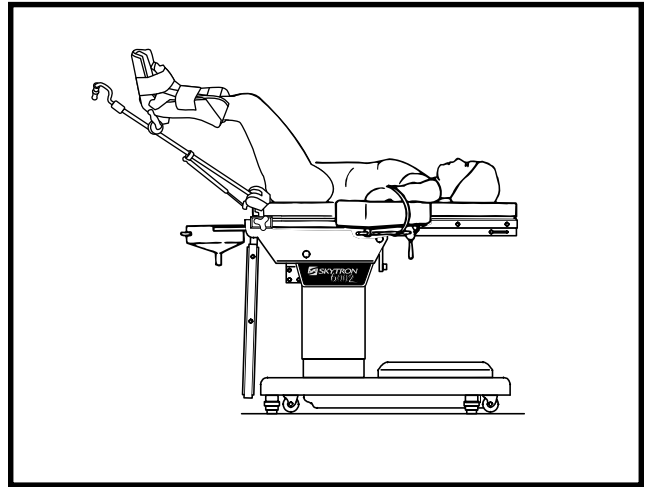

**Lithotomy Basic Position**

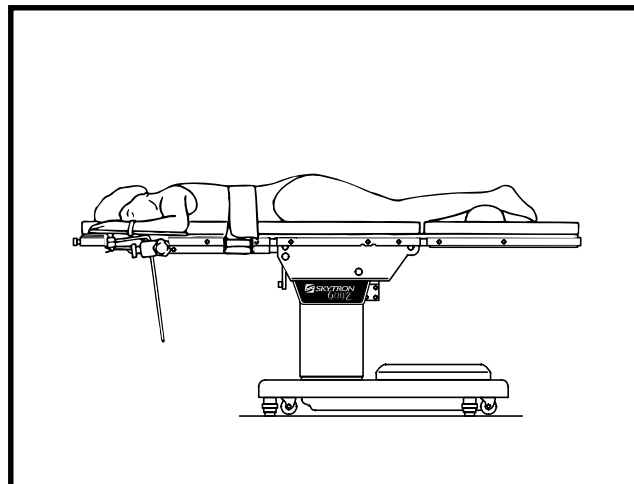

**Prone Supine Position Rotated 180°**

## SECTION IV MAINTENANCE

### 4-1. Preventive Maintenance

The following preventive maintenance checks and services are recommended to ensure the serviceability and proper operation of your SKYTRON Surgical Table.

a. During normal cleaning, a general visual examination should be made checking for leaks, loose bolts or parts, and cracked, chipped, or missing paint. Any necessary repairs should be made.

b. Semi-annually the following checks and services should be performed:

1. Check all hydraulic fittings, mini-valves and slave cylinders for proper operation and any signs of leaks.
2. Check the hydraulic speed controls and adjust if necessary.
3. Pressure check (with a gauge) the pressure relief valve.
4. Check all mechanical adjustments and adjust as necessary.
5. Check hydraulic fluid level.
6. Lubricate the slider assembly.

### 4-2. Cleaning Recommendations

#### NOTE

Always follow current AORN Journal Guidelines to ensure proper cleaning and disinfection procedure.



**CAUTION**



Caution should be taken when cleaning the table to prevent excessive fluid entry into electrical connectors.

The following procedures should be followed when cleaning the surgical table between cases.

Place table top in level position prior to starting cleaning procedure.



**WARNING**



Always follow OSHA blood-borne pathogens standards for protective clothing, including gloves, masks and eye protection when cleaning the surgical table.

Remove major contaminants from the table with disposable materials following appropriate biohazard waste disposal procedures.

Remove all table pads and place them on a flat surface for cleaning.



**CAUTION**



Thoroughly read and follow the manufacturer's directions for all cleaning fluids. DO NOT use cleaners containing phenolics.

Apply cleaning fluid liberally to top and sides of each pad and wipe with a clean lint-free cloth.

Using a clean, damp, lint-free cloth, wipe the pads to remove the cleaning fluid.

Using a clean, dry, lint-free cloth, wipe the pads to remove all moisture.

Repeat the steps to clean the bottom of the each pad.



### CAUTION



When using spray cleaners DO NOT spray fluids directly into electrical receptacles or micro switches.

Repeat cleaning procedure for all table surfaces including the top, sides, elevation column, base and all accessories.



### CAUTION



Before replacing pads on the table, make sure the pads and all mating surfaces are completely dry. Moisture trapped between the pads and mating surfaces may cause distortion of table tops.

When the cleaning procedure is complete, replace all pads and accessories as applicable.

Remove pendant control from table side rail and apply cleaning solution to the pendant control and cord.

Use a clean cloth dampened with water to remove cleaning solution.

Use another clean damp cloth to remove any remaining residue.

Install pendant control on side rail for storage when cleaning procedure is complete.

### 4-3. Service

Table maintenance can be performed by trained maintenance personnel using SKYTRON authorized replacement parts and service techniques. Service instructions and parts are available from SKYTRON.

Preventive Maintenance contracts are available through your local SKYTRON representative.

To obtain service instructions, replacement parts, factory service or preventive maintenance contracts, contact your nearest SKYTRON representative or write or call:

**SKYTRON**  
**5000 36th Street S.E.**  
**Grand Rapids, MI 49512**  
**1-800-SKYTRON (1-800-759-8766)**  
**Fax. 1-616-957-5053**

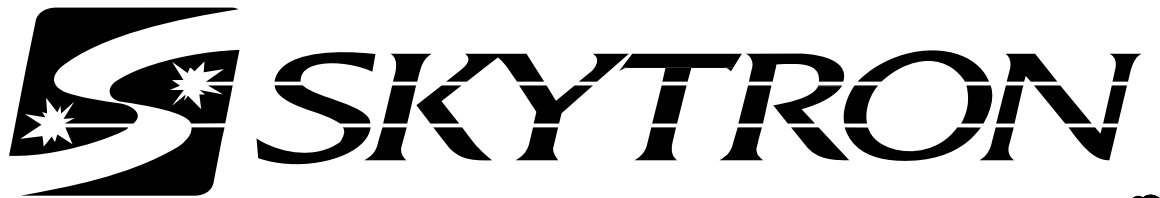

# PARTS CATALOG

## 6002 SERIES SURGICAL TABLES

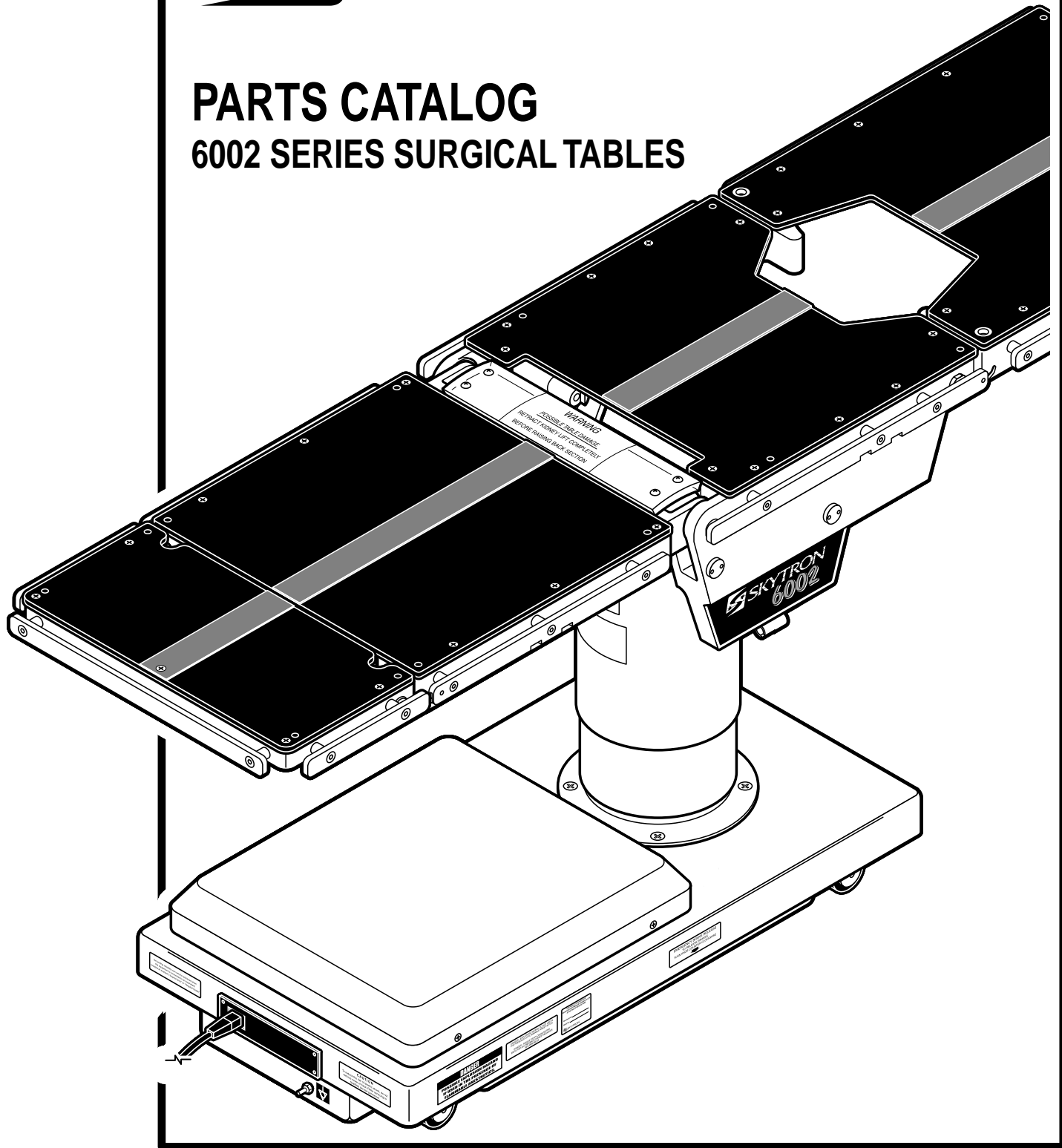



---

# INTRODUCTION

---

This manual contains the exploded views and replacement parts lists for the serviceable components of the SKYTRON Model 6002 Surgical Table.

Each serviceable part in these exploded views is identified by a reference number. Use this number to locate necessary part information in the parts list adjacent to the exploded view.

Always use the complete SKYTRON part number and description when ordering replacement parts.

**Always use the complete table serial number (S.N.) when ordering replacement parts.**

**Special Tools and Maintenance Items listed on page 34.**

## Abbreviations

As Required .....	A/R
Optional .....	opt
Serial Number .....	S.N.
All Later S.N.'s .....	&L
All Prior S.N.'s .....	&P
Not Shown.....	NS

**REV 4/05**

Although current at the time of publication, SKYTRON's policy of continuous development makes this manual subject to change without notice.

---

1. Top & Side Frame Assemblies ..... Page 2

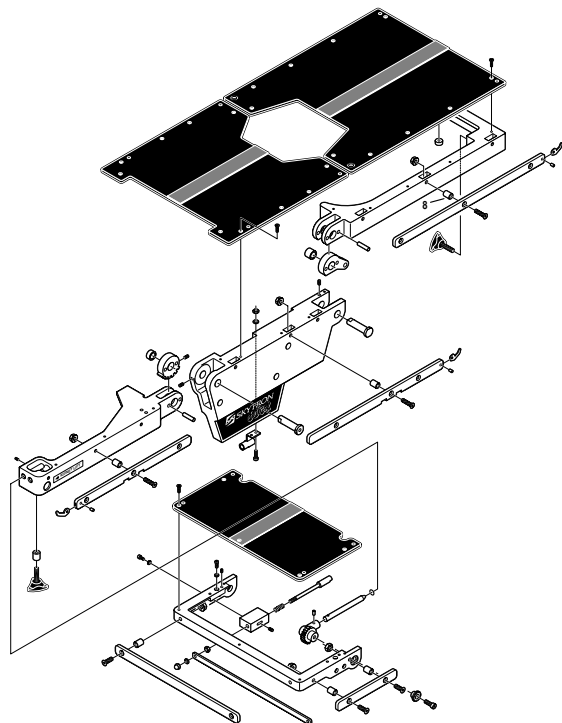

2. Kidney Lift Assembly ..... Page 6

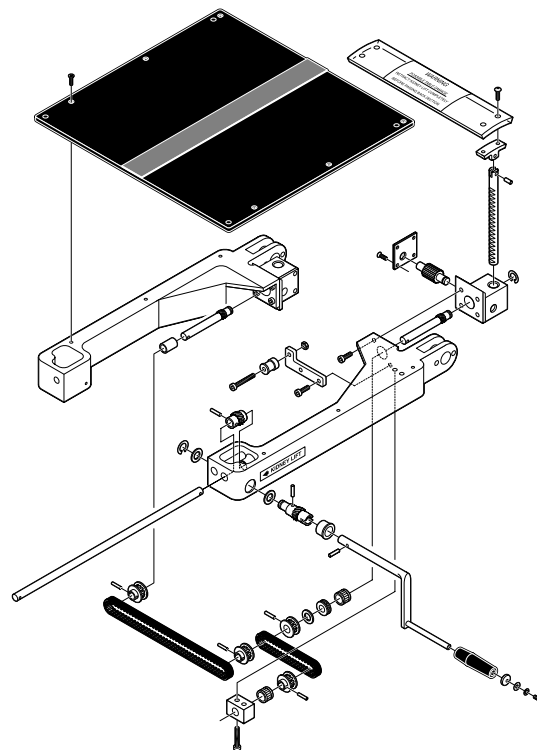

3. Side Frame & Hydraulic Cylinders ..... Page 10

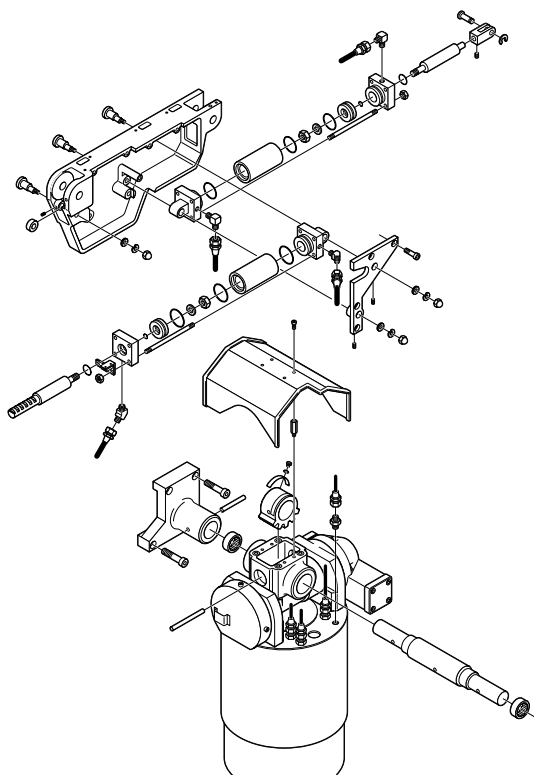

4. Trendelenburg & Lateral Tilt Cylinders ..... Page 14

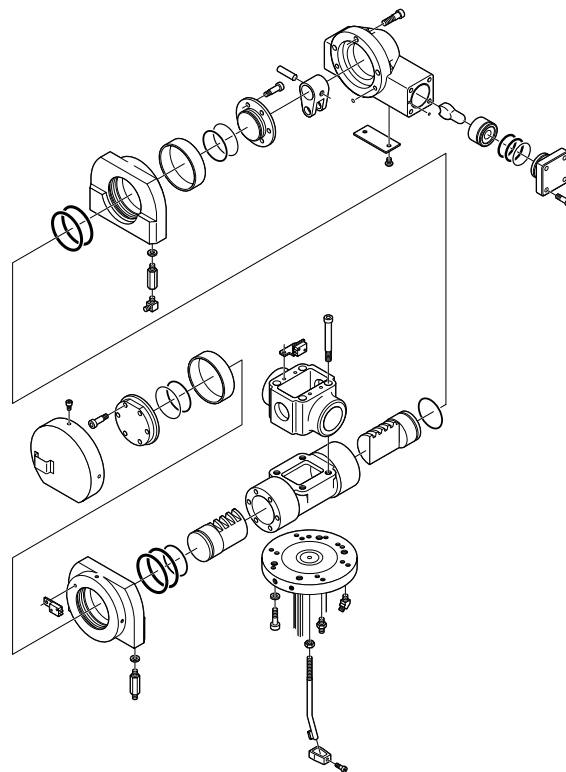

5. Support Column Assembly ..... Page 16

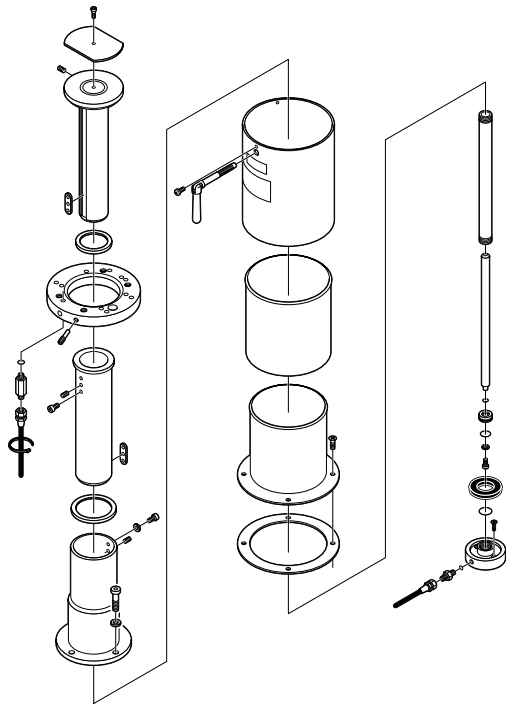

6. Electrical Components ..... Page 18

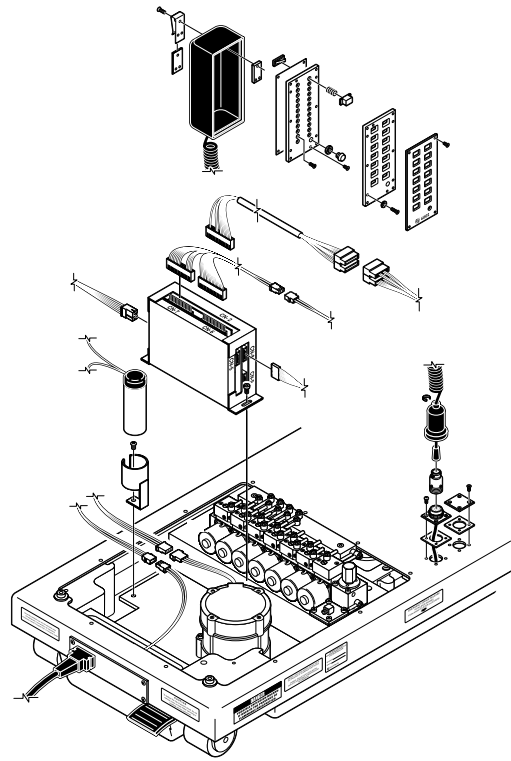

7. Electrical Components, Battery Model ..... Page 20

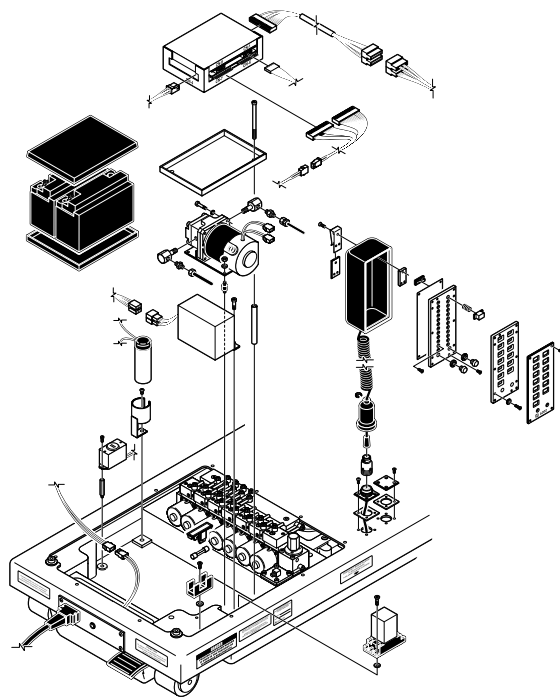

8. Hydraulic Valves & Fittings ..... Page 24

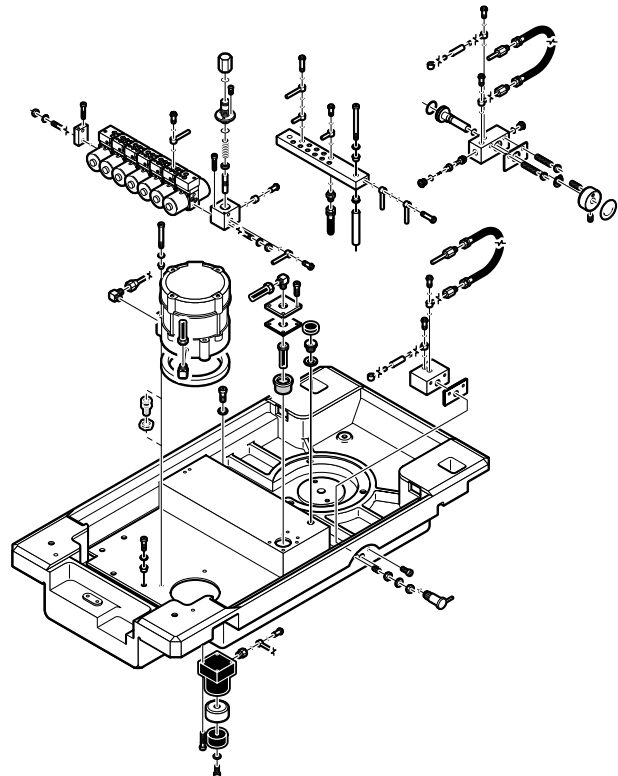

9. Electro / Mini Valve Assembly ..... Page 28

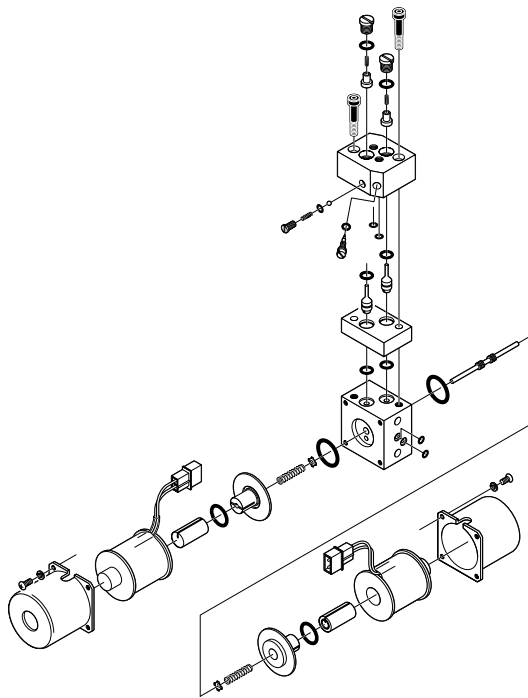

10. Base Assembly ..... Page 30

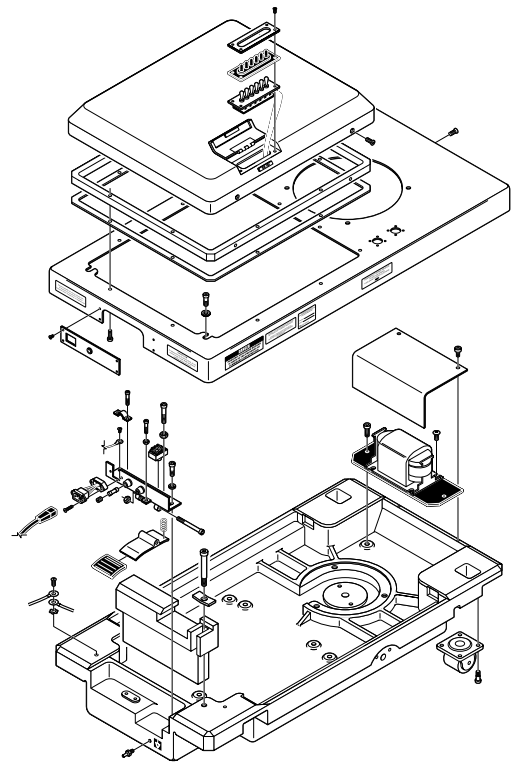

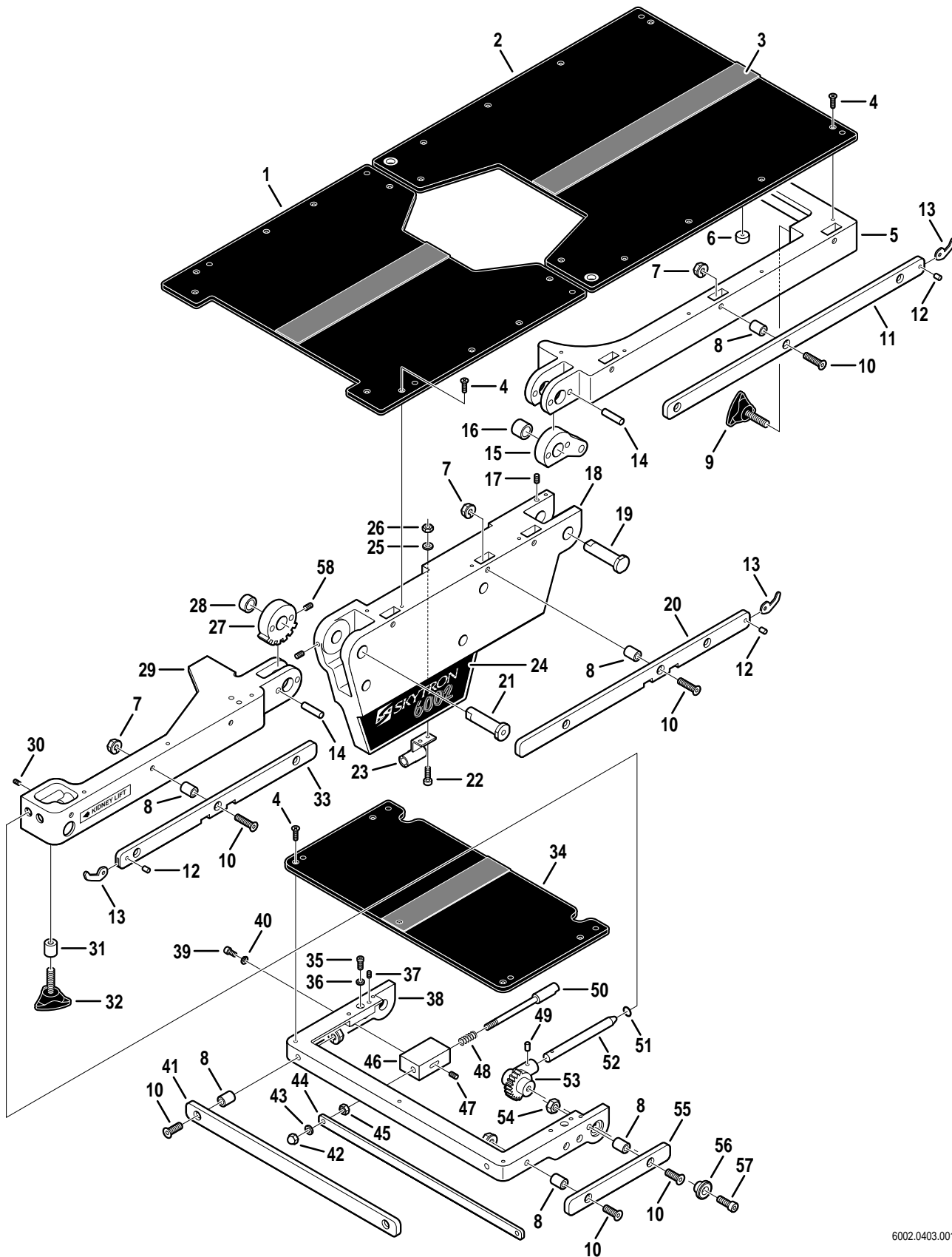

Item	Part No.	Description	Qty.
	1-010-22-P	PAD SET, regular .....	opt
	1-010-22-S	PAD SET, soft .....	opt
1	D3-031-37	TOP, seat section .....	1
2	D3-030-03	TOP, foot/leg section .....	1
3	D3-010-18-H	VELCRO, hook (specify length) .....	A/R
4	D3-010-19	SCREW, phillips hd. ....	A/R
5	D3-031-64	FRAME, foot/leg section .....	1
6	D6-031-23	RUBBER STOP, foot/leg section .....	1
7	D6-032-34	NUT, M8 w/lockwasher .....	A/R
8	D3-010-01	COLLAR, side rail .....	A/R
9	D6-031-01	KNOB, locking .....	2
10	D6-010-12	SCREW, allen, M8x45 .....	A/R
11	D3-030-10	RAIL, side, foot/leg section, right .....	1
	D3-030-09	RAIL, side, foot/leg section, left .....	1
12	D3-010-41	PIN, rail stop .....	6
13	D3-010-43	STOP, rail, large .....	6
14	D6-010-03	PIN, tapered, spur gear, M7x40 .....	8
15	D3-031-01	LEVER, axis, foot/leg section .....	2
16	D3-131-01	BUSHING, foot/leg section lever .....	2
17	D6-010-50	SCREW, set, M6x15 .....	4
18	D3-131-02	FRAME, side, right .....	1
	D3-131-03	FRAME, side, left .....	1
19	D3-030-05	AXIS, foot/leg section .....	2
20	D3-030-08	RAIL, side, seat section, right .....	1
	D3-030-07	RAIL, side, seat section, left .....	1
21	D3-010-04	AXIS, back section .....	2
22	D6-010-70	BOLT, allen, M5x10 .....	2
23	D3-031-61-L	BRACKET, crank storage .....	1
24	D6-031-31	DECAL, SKYTRON 6002 .....	2
	D6-031-32	DECAL, SKYTRON 6002B .....	2
25	D6-010-77-1	WASHER, lock, M5 .....	2
26	D6-010-76-1	NUT, M5 .....	2
27	D3-031-28	GEAR, spur, back section .....	2
28	----	BUSHING, back section spur gear (not available separately) .....	2
29	D3-031-15	FRAME, back section, right .....	1
	D3-031-16	FRAME, back section, left .....	1
30	D6-031-66	SCREW, set, M5x10 .....	2
31	D3-031-82	BUSHING .....	2
32	D3-031-83	KNOB, head rest .....	2
33	D3-031-62	SIDE RAIL, back section, right .....	1
	D3-031-63	SIDE RAIL, back section, left .....	1
34	D3-032-04	TOP, head section .....	1
35	D6-010-38	BOLT, allen, M6x15 .....	2
36	D6-010-40	WASHER, lock, M6 .....	2
37	D6-010-41	SCREW, set, M8x15 .....	2
38	D3-032-05	FRAME, head section .....	1
39	D6-010-38	BOLT, allen, M6x15 .....	4
40	D6-010-40	WASHER, lock, M6 .....	4
41	D3-010-20	RAIL, accessory .....	1

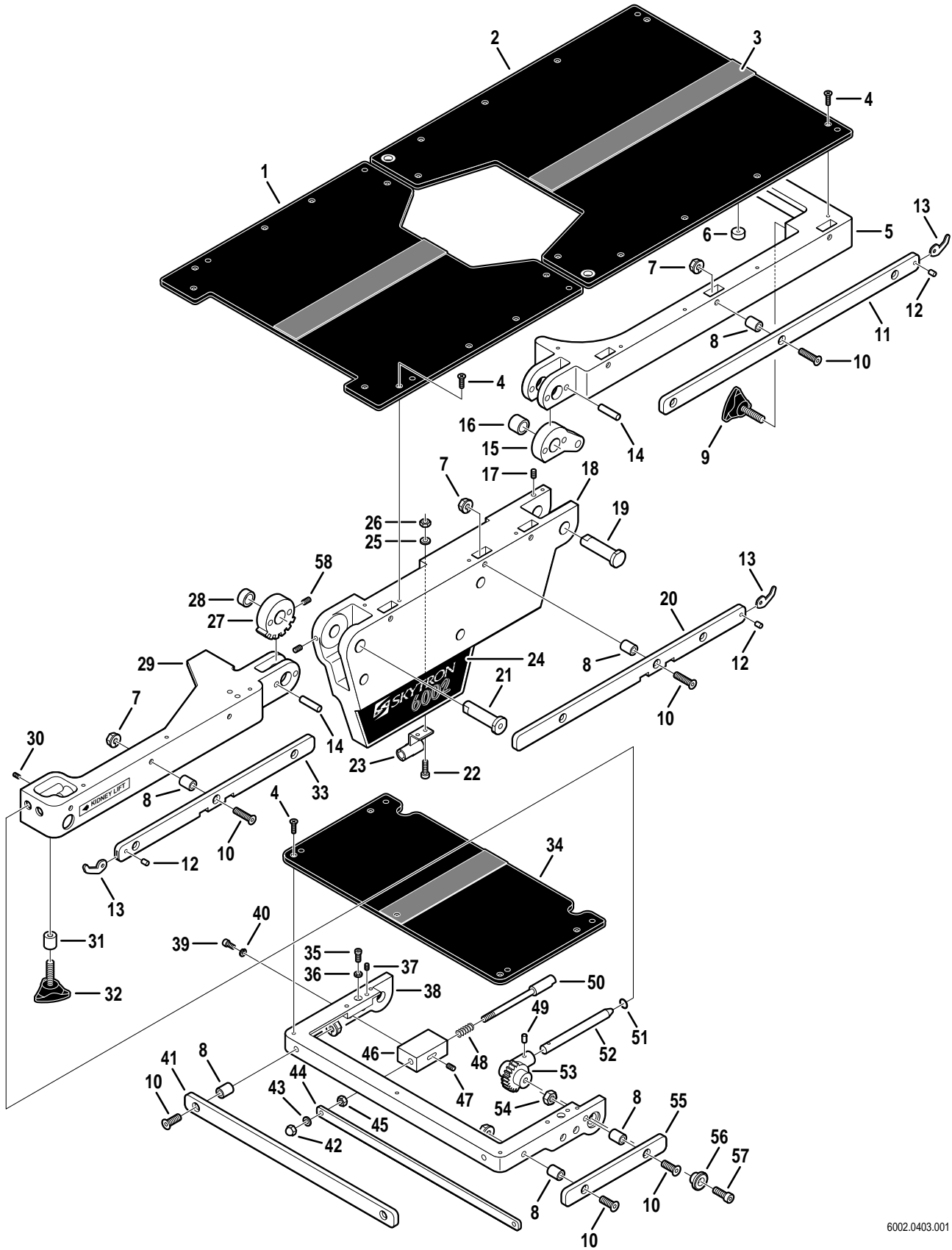

Item	Part No.	Description	Qty.
42	D6-010-08	NUT, acorn, M8 .....	2
43	D6-010-09	WASHER, lock, M8 .....	2
44	D3-010-24	RELEASE BAR, head section .....	1
45	D6-010-13	NUT, M8 .....	2
46	D3-032-40	BLOCK, bearing .....	2
47	D6-010-11	SCREW, set, M5x8 .....	2
48	D3-010-26	SPRING, release .....	2
49	D6-050-33	PIN, roll, M5x20 .....	A/R
50	D3-010-27	PLUNGER, release .....	2
51	D4-010-14	O-RING, P-12 .....	2
52	D3-010-31-1	SHAFT, extension, head section (roll pin) .....	2
53	D3-032-80	GEAR, trunnion, right .....	1
	D3-032-81	GEAR, trunnion, left .....	1
54	D6-010-13	NUT, M8 .....	2
55	D3-031-67-1	RAIL, side, head section .....	2
56	D3-034-22	BUSHING, head section .....	2
57	D6-010-53	BOLT, allen, M8x20 .....	2
58	D6-010-50	SCREW, set, M6x15 .....	2



2. KIDNEY LIFT ASSEMBLY

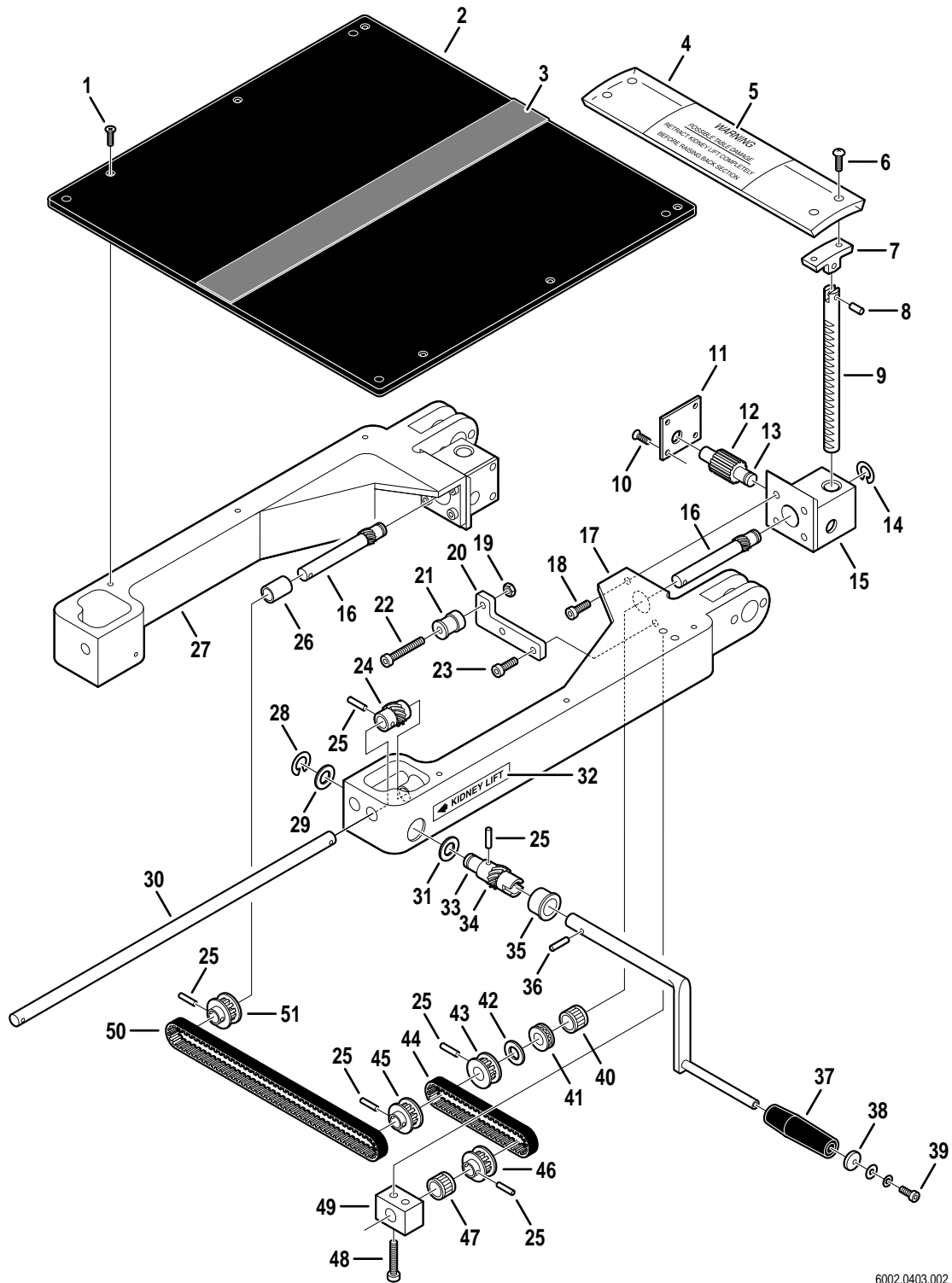

Item	Part No.	Description	Qty.
1	D3-010-19	SCREW, phillips hd. ....	A/R
2	D3-031-65	TOP, back section .....	1
3	D3-010-18-H	VELCRO, hook (specify length) .....	A/R
4	D3-031-77	TOP, kidney lift .....	1
5	D6-031-57	DECAL, kidney bridge warning .....	1
6	D6-031-52	SCREW, round hd. ....	4
7	D3-031-39	PIVOT ASSEMBLY .....	2
8	D6-031-24	PIN, roll, M5x12 .....	2
9	D3-031-40	SHAFT, elevation .....	2
10	D6-031-05	SCREW, phillips, M4x10 .....	8
11	D3-031-43	COVER, gear housing, right .....	1
	D3-031-44	COVER, gear housing, left .....	1
12	D3-031-45	GEAR .....	2
13	D3-031-46	SHAFT, gear .....	2
14	D6-031-62	CIRCLIP, E7 .....	A/R
15	D3-031-41-1	HOUSING, gear, right.....	1
	D3-031-42-1	HOUSING, gear, left .....	1
16	D3-031-02	WORM GEAR, S.N.6002-019 & L/6002B-008 & L. ....	2
	D3-031-03	WORM GEAR, S.N.6002-018 & P/6002B-007 & P. ....	2
17	D3-031-15	FRAME, back section, right .....	1
18	D6-031-63	BOLT, allen, M6x15 .....	3
	D6-031-64	BOLT, allen, M6x20 .....	4
19	D6-010-41	NUT, M6 .....	1
20	D3-031-98	BRACKET .....	1
21	D3-010-13	IDLER, S.N.6002-019 & L/6002B-008 & L .....	1
	D3-010-14	IDLER, S.N.6002-018 & P/6002B-007 & P .....	1
22	D6-010-39-1	BOLT, allen, M6x45, S.N.6002-019 & L/6002B-008 & L .....	1
	D6-031-67	BOLT, allen, M6x40, S.N.6002-018 & P/6002B-007 & P .....	1
23	D6-010-91	BOLT, allen, M6x25 .....	A/R
24	D3-031-93	GEAR, drive, S.N.6002-019 & L/6002B-008 & L .....	1
	D3-031-94	GEAR, drive, S.N.6002-018 & P/6002B-007 & P .....	1
25	D6-050-33	PIN, roll, M5x20 .....	A/R
26	D3-031-95	COLLAR, S.N.6002-019 & L/6002B-008 & L .....	1
	D3-031-96	COLLAR, S.N.6002-018 & P/6002B-007 & P .....	1
27	D3-031-16	FRAME, back section, left .....	1
28	D6-010-07	CIRCLIP, E10 .....	1
29	D6-031-65	WASHER .....	1
30	D3-031-84	SHAFT, gear, S.N.6002-019 & L/6002B-008 & L .....	1
	D3-031-52	SHAFT, gear, S.N.6002-018 & P/6002B-007 & P .....	1
31	D3-031-81	WASHER, delrin .....	1
32	D6-031-54	DECAL, kidney lift .....	1
33	D3-031-80	SHAFT, drive gear .....	1
34	D3-031-53	GEAR, drive .....	1
35	D3-031-79	BUSHING .....	1
36	D6-031-11	PIN, roll, M5x17 .....	1
	D3-031-60	HANDLE ASSEMBLY, k-lift crank .....	1
37	D3-031-56	•HANDLE, k-lift crank .....	1
38	D6-031-12	•WASHER, flat, M5 (plated) .....	1
39	D6-010-28-1	•BOLT, allen, M5x6 (plated) .....	1

2. KIDNEY LIFT ASSEMBLY (continued)

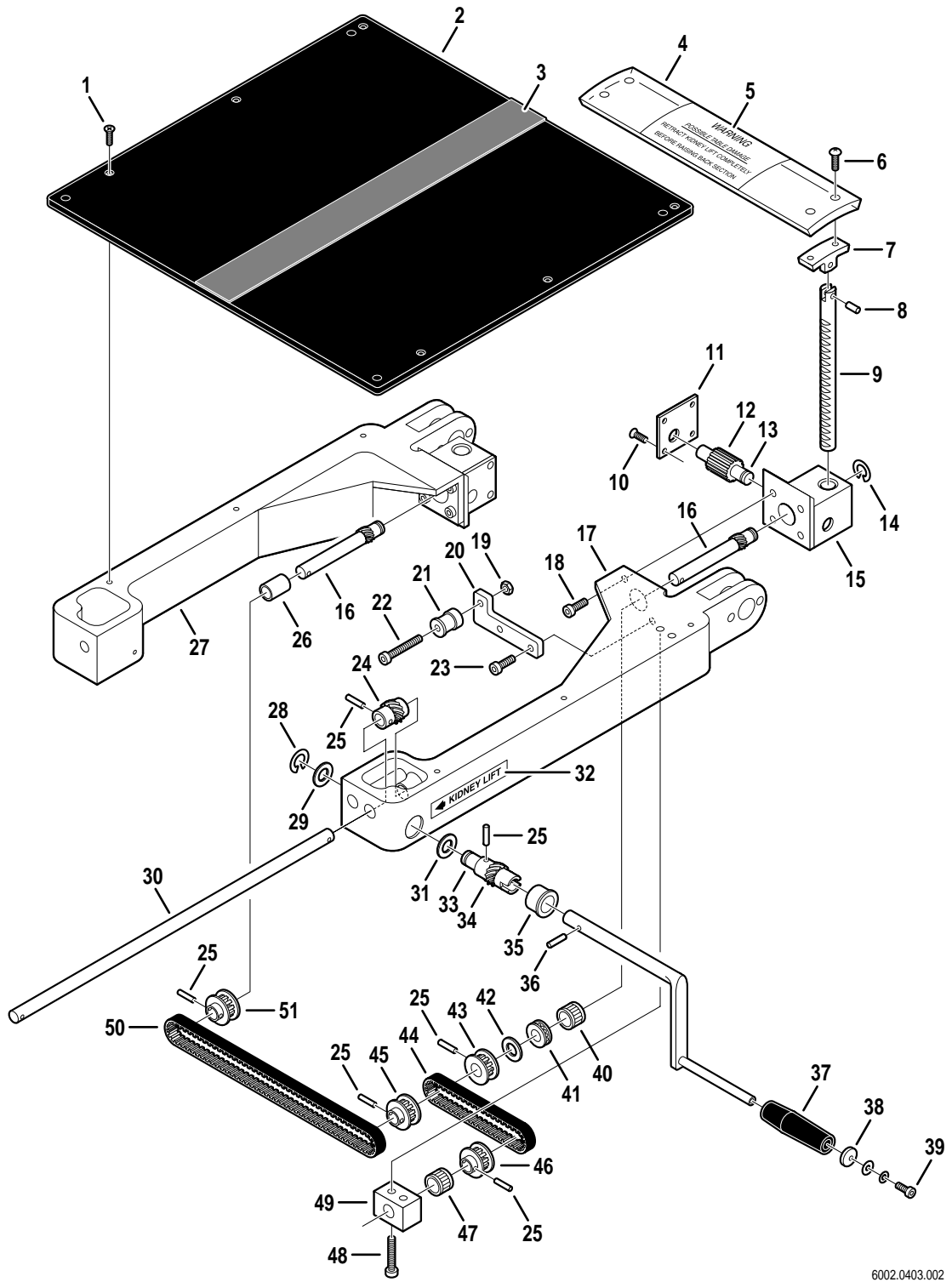

6002.0403.002

Item	Part No.	Description	Qty.
40	D3-010-15	BUSHING, S.N.6002-019 & L/6002B-008 & L.....	1
	D3-010-16	BUSHING, S.N. 6002-018 & P/6002B-007 & P.....	1
41	D3-031-91	BEARING, thrust .....	1
42	D3-031-92	COLLAR .....	1
43	D3-031-90	PULLEY, S.N.6002-019 & L/6002B-008 & L .....	1
44	D3-031-86	BELT .....	1
45	D3-031-88	PULLEY, S.N.6002-019 & L/6002B-008 & L .....	1
	D3-031-89	PULLEY, S.N.6002-018 & P/6002B-007 & P .....	1
46	D3-031-85	PULLEY .....	1
47	D3-031-78	BEARING, needle .....	1
48	D6-031-59-1	BOLT, allen, M6x40 .....	2
49	D3-031-51	BLOCK, guide.....	1
50	D3-031-87	BELT .....	1
51	D3-031-97	PULLEY .....	1

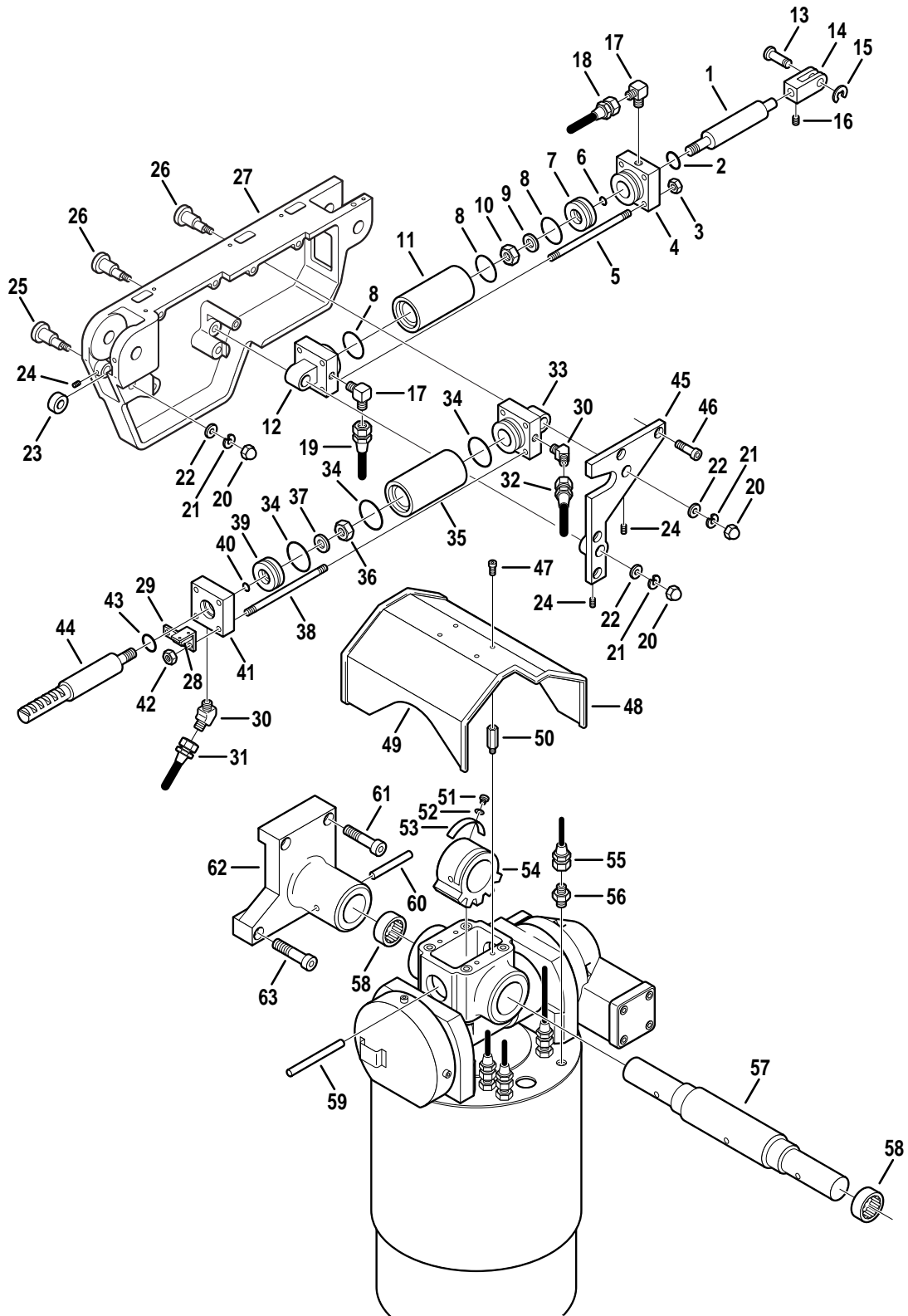

Item	Part No.	Description	Qty.
--	D4-032-02	CYLINDER ASSEMBLY, foot/leg section .....	2
1	D4-034-08	•RAM .....	1
2	D4-010-03	•O-RING, P-25 .....	1
3	D6-010-55	•NUT, M8 .....	4
4	D4-034-09	•HEAD CAP .....	1
5	D4-010-48	•STUD, cylinder .....	4
6	D4-010-02	•O-RING, P-14 .....	1
7	D4-034-10	•PISTON .....	1
8	D4-010-54	•O-RING, P-34 .....	3
9	D4-010-42	•WASHER, lock, M10 .....	1
10	D6-010-43	•NUT, M10 .....	1
11	D4-034-11	•CYLINDER .....	1
12	D4-034-12	•TAIL CAP .....	1
13	D6-030-03	PIN, clevis .....	2
14	D6-031-19	CLEVIS .....	2
15	D6-030-01	CIRCLIP .....	2
16	D6-010-34	SCREW, set, M6x6 .....	2
17	D4-010-29	FITTING, hydraulic, 90° elbow .....	4
18	D4-032-03	HOSE, flexible, foot/leg section ram, left .....	1
	D4-032-04	HOSE, flexible, foot.leg section ram, right .....	1
19	D4-032-05	HOSE, flexible, foot/leg section piston, left .....	1
	D4-032-06	HOSE, flexible, foot/leg section piston, right .....	1
20	D6-010-08	NUT, acorn, M8 (plated) .....	6
21	D6-010-09-1	WASHER, lock, M8 (plated) .....	6
22	D6-010-72	WASHER, flat, M8 (plated) .....	6
23	D3-010-36	BEARING, support .....	2
24	D6-010-34	SCREW, set, M6x6 .....	A/R
25	D3-010-38	AXIS, eccentric cam, bearing .....	2
26	D3-010-37	AXIS, eccentric cam, cylinder .....	4
27	D3-131-03	FRAME, side, left .....	1
	D3-131-02	FRAME, side, right .....	1
28	D5-032-15	MICRO-SWITCH .....	2
29	D3-032-42	BRACKET, micro-switch mounting, left .....	1
	D3-032-42-3	BRACKET, micro-switch mounting, right .....	1
30	D4-010-30	FITTING, hydraulic, 45° elbow .....	4
31	D4-032-09	HOSE, flexible, back section ram, left .....	1
	D4-032-10	HOSE, flexible, back section ram, right .....	1
32	D4-032-07	HOSE, flexible, back section piston, left .....	1
	D4-032-08	HOSE, flexible, back section piston, right .....	1
--	D4-032-01	CYLINDER ASSEMBLY, back section .....	2
33	D4-034-13	•TAIL CAP .....	1
34	D4-010-04	•O-RING, P-44 .....	3
35	D4-034-14	•CYLINDER .....	1
36	D6-010-43	•NUT, M10 .....	1
37	D6-010-42	•WASHER, lock, M10 .....	1
38	D4-010-48	•STUD, cylinder .....	4
39	D4-034-15	•PISTON .....	1
40	D4-010-02	•O-RING, P-14 .....	1
41	D4-034-16	•HEAD CAP .....	1
42	D6-010-55	•NUT, M8 .....	4

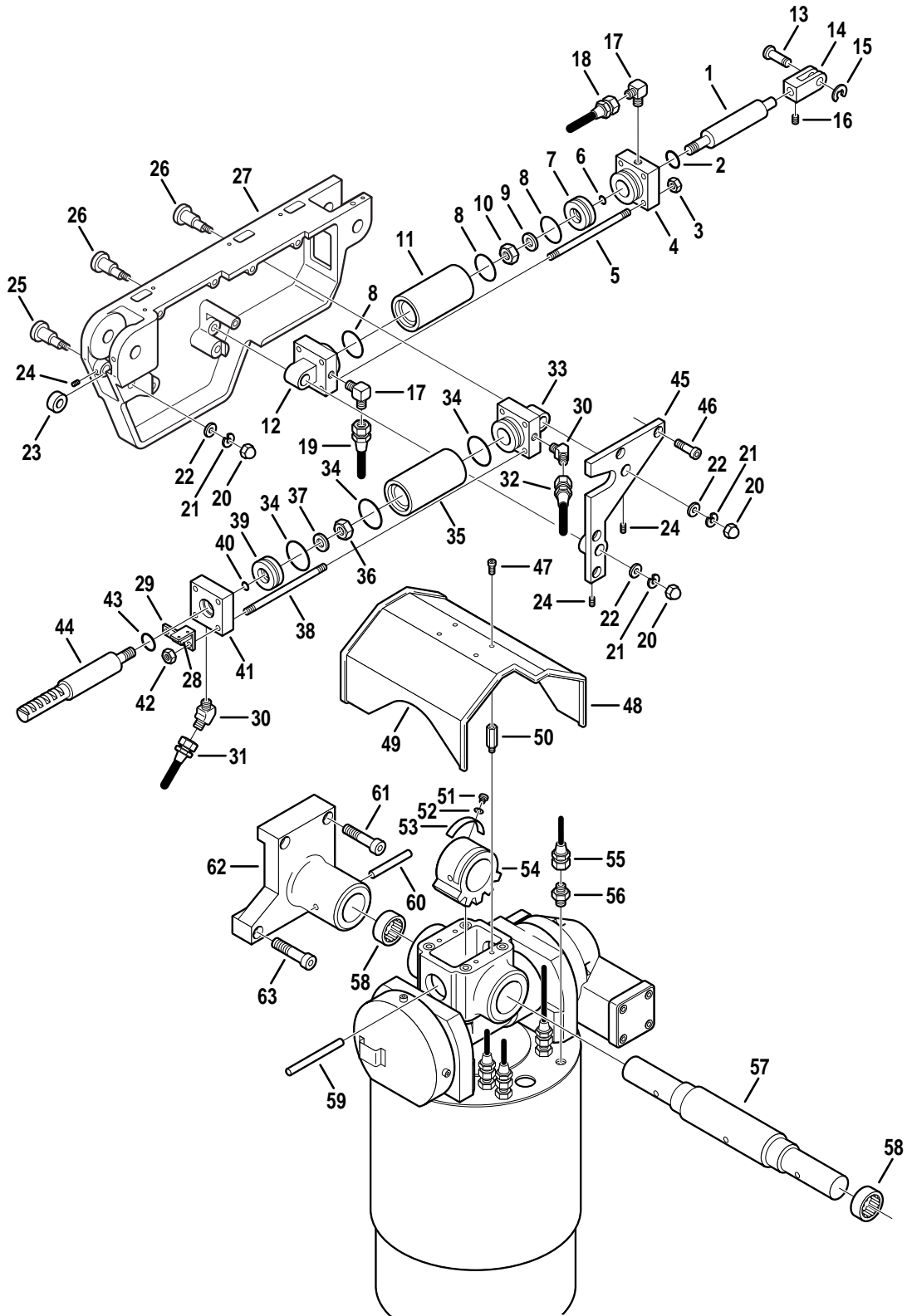

Item	Part No.	Description	Qty.
43	D4-010-03	•O-RING, P-25 .....	1
44	D4-034-17	•RAM .....	1
45	D4-034-38	BRACE, side frame, left .....	1
	D4-034-39	BRACE, side frame, right .....	1
46	D6-010-17-1	BOLT, allen, M8 x 15 (plated) .....	8
47	D6-010-70-1	BOLT, allen, M5x10 (plated) .....	4
48	D2-032-05	END CAP, cover, right .....	1
	D2-032-05-A	END CAP, cover, left .....	1
49	D2-032-04	COVER, flexible hose .....	1
50	D2-010-38	STAND-OFF, cover .....	4
51	D6-050-36	BOLT, allen, M5x8 .....	4
52	D6-034-04	WASHER, flat, M5 .....	4
53	D2-032-48	RAMP, micro-switch .....	2
54	D2-032-32	GEAR, Trendelenburg .....	1
55	D4-032-03	HOSE, flexible, foot/leg section, ram, left .....	1
	D4-032-04	HOSE, flexible, foot/leg section, ram, right .....	1
56	D4-031-06	FITTING, flexible hose .....	A/R
57	D3-032-03	AXIS, Trendelenburg .....	1
58	D2-032-01	BEARING, Trendelenburg axis .....	2
59	D6-010-07	PIN, tapered, M12x90 .....	1
60	D6-032-01	PIN, tapered .....	2
61	D6-010-71-1	BOLT, allen, M10x40 (plated) .....	A/R
62	D3-034-36	INNER CASTING, side frame, left .....	1
	D3-034-37	INNER CASTING, side frame, right .....	1
63	D6-010-10-1	BOLT, allen, M10x45 (plated) .....	A/R



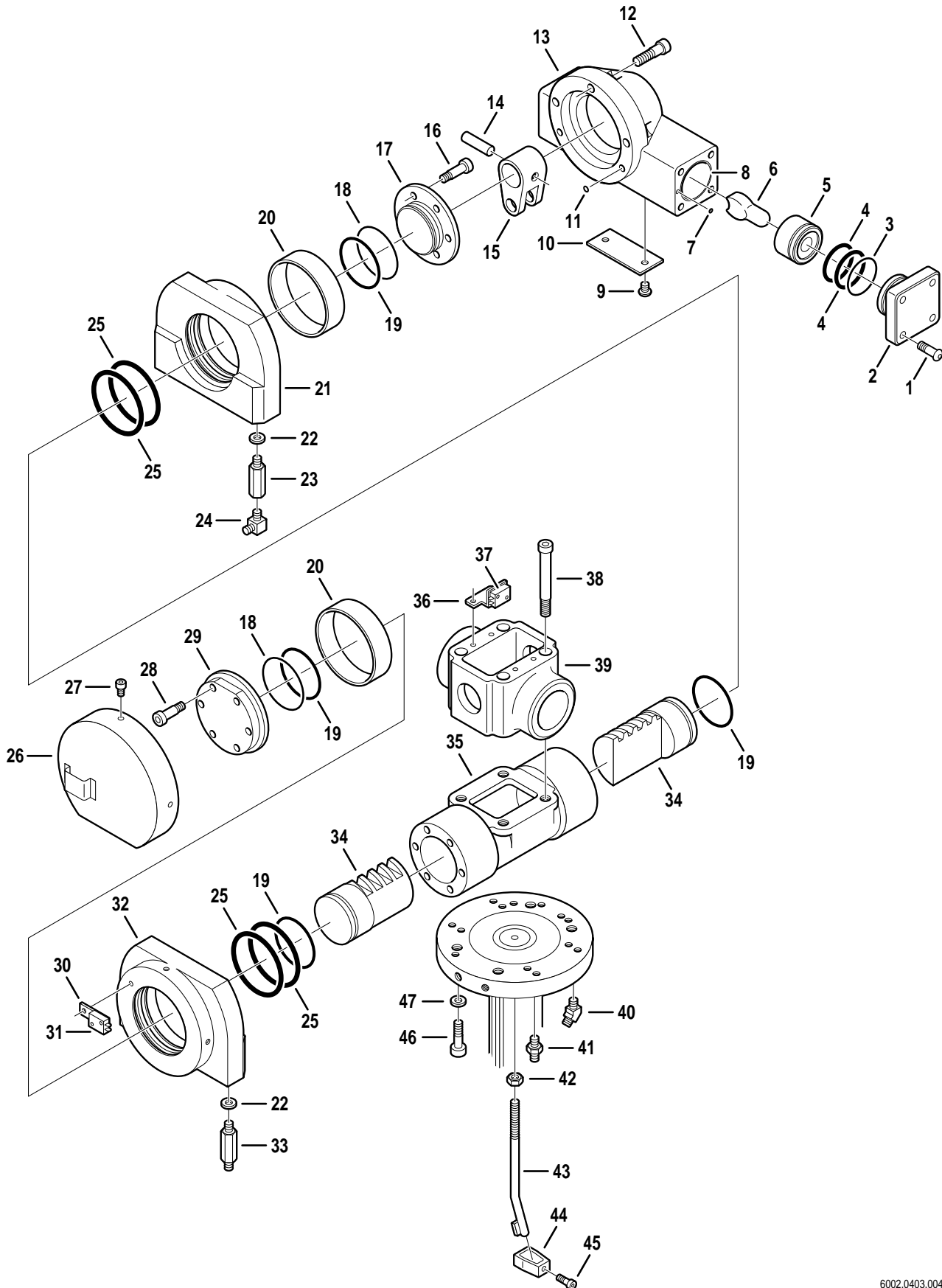

Item	Part No.	Description	Qty.
1	D6-010-33-1	BOLT, allen, M8 x 25 (plated) .....	8
	D6-032-48	BOLT, button head, M8 x 25 .....	8
2	D2-032-69	CAP, lateral tilt, right .....	1
	D2-032-70	CAP, lateral tilt, left .....	1
3	D4-032-79	O-RING, S-55 .....	2
4	D4-060-24	O-RING, P-49 .....	4
5	D2-032-08-1	PISTON, lateral tilt .....	2
6	D2-032-07-1	ROD, piston .....	2
7	D4-010-52	O-RING, P-4 .....	A/R
8	D2-034-01	SLEEVE .....	2
9	D6-010-16-1	SCREW, phillips hd., M5 x 6, stainless .....	2
10	D2-032-10	PLATE, inspection cover .....	1
	D2-032-47	PLATE, inspection cover, battery model .....	1
11	D4-010-01	O-RING, P-8 .....	2
12	D6-010-45	BOLT, allen, M10 x 30 .....	3
13	D2-032-68	HOUSING, lateral tilt .....	1
14	D6-031-28	PIN, tapered, 12 x 55, S.N. 6002 --118 &P, 6002B -- 052 &P .....	1
15	D2-032-12-1	LEVER, lateral tilt motion, S.N. 6002 --118 &P, 6002B -- 52 &P .....	1
16	D6-010-30	BOLT, allen, M6 x 20 .....	6
17	D2-032-13-1	CAP, tail, S.N. 6002 -- 118 &P, 6002B -- 052 &P .....	1
--	D2-034-02	CAP, tail, S.N. 6002 -2J-119 &L, 6002B -2J-053 &L .....	1
18	D4-032-80	O-RING, S-70 .....	2
19	D4-010-06	O-RING, P-60 .....	4
20	D2-032-14	BUSHING, graphite .....	2
21	D2-032-15	PIVOT BLOCK, lateral tilt, tail .....	1
22	D4-010-32	PACKING, copper .....	A/R
23	D4-010-99	FITTING, plumbing .....	A/R
24	D4-010-29	FITTING, hydraulic, 90° elbow .....	A/R
25	D4-010-07	O-RING, P-95 .....	4
26	D2-032-20	COVER, Trendelenburg cylinder .....	1
27	D6-010-70-1	BOLT, allen, M5x10 (plated) .....	3
28	D6-010-30-1	BOLT, allen, M6 x 20 (plated) .....	6
29	D2-032-19	CAP, head, Trendelenburg cylinder .....	1
30	D2-032-45	BRACKET, micro-switch .....	2
31	D5-032-15	MICRO-SWITCH, lateral tilt .....	2
32	D2-032-18	PIVOT BLOCK, lateral tilt, head .....	1
33	D4-010-33	FITTING, flexible hose, long .....	A/R
34	D2-032-31	PISTON, Trendelenburg .....	2
35	D2-032-33	HOUSING, Trendelenburg .....	1
36	D2-032-46	BRACKET, micro-switch .....	2
37	D5-032-16	MICRO-SWITCH, Trendelenburg .....	2
	D2-032-66	ACTUATOR, micro-switch .....	1
38	D6-010-29	BOLT, allen, M10 x 85 .....	4
39	D2-032-16	CASTING, Trendelenburg bearing .....	1
40	D4-010-30	FITTING, hydraulic, 45° elbow .....	A/R
41	D4-031-06	FITTING, flexible hose .....	A/R
42	D6-011-07	NUT, M12 .....	2
43	D2-032-71	BAR, hose guide .....	2
44	D2-010-45	HOLDER, hose .....	2
45	D6-011-08	BOLT, allen, M5 x 18 .....	2
46	D6-011-06	BOLT, allen, M12 x 45 .....	2
47	D6-010-21	WASHER, lock, M12 .....	2

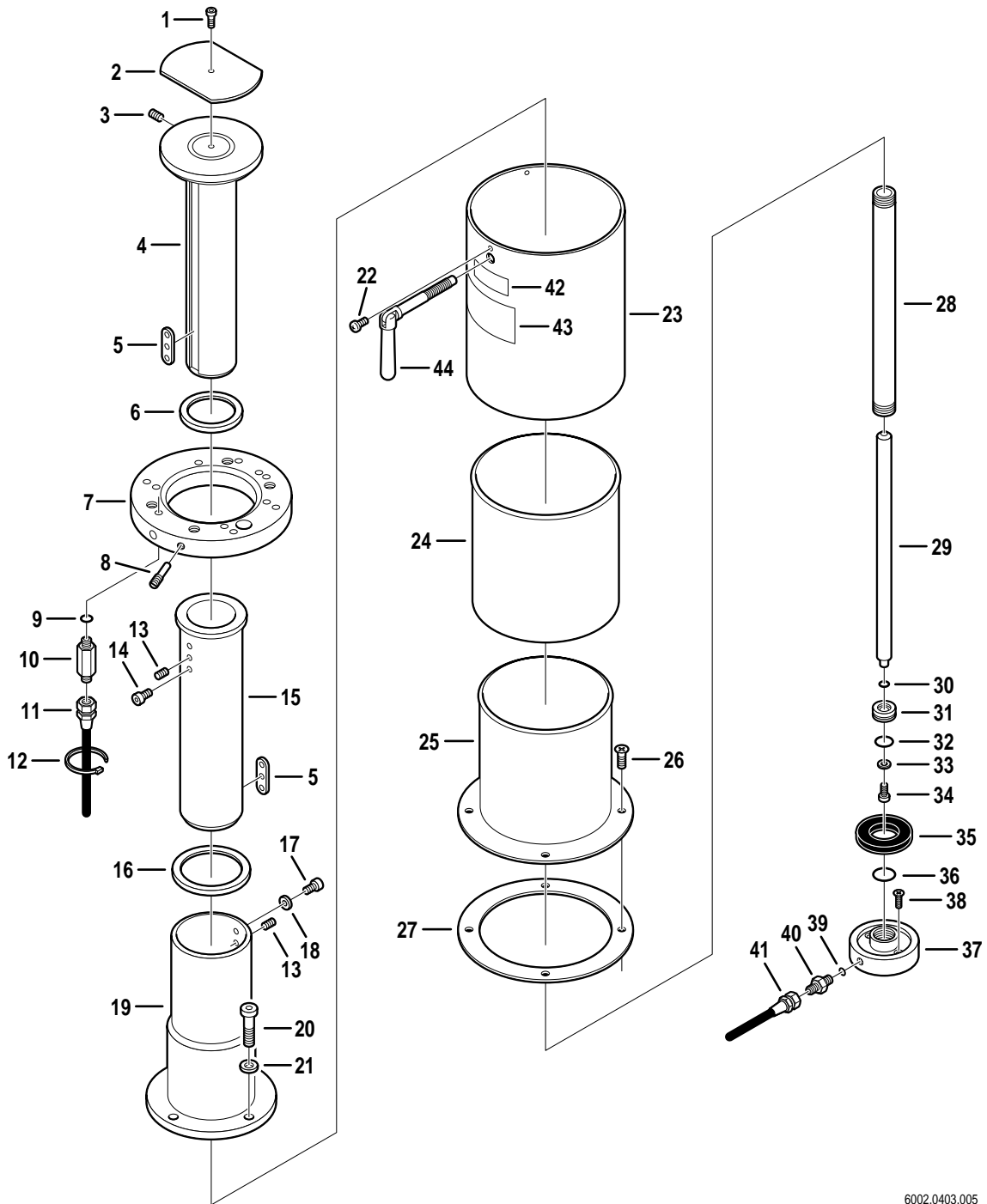

Item	Part No.	Description	Qty.
	D2-010-17-1	SLIDER ASSEMBLY .....	1
1	D6-010-28	BOLT, allen, M5x6 .....	1
2	D2-010-21	PLATE, elevation slider head .....	1
3	D6-010-27	SCREW, set, M10x15 .....	2
4	D2-031-20	SLIDER, small .....	1
5	D2-010-16	KEY, slider .....	2
6	D2-010-19	STOPPER, slider, small .....	1
7	D2-031-10	RING, elevation clamp .....	1
8	D6-010-26	STOPPER, rotation, M10x20 .....	2
9	D4-010-32	PACKING, copper .....	A/R
10	D4-010-33	FITTING, flexible hose, long .....	3
11	D4-010-21-1	HOSE, flexible, 1010mm .....	A/R
	D4-010-21-3	HOSE, flexible, 980mm .....	A/R
	D4-010-21	HOSE, flexible, 1030mm .....	A/R/
	D4-010-21-6	HOSE, flexible, 1110mm .....	A/R
12	D6-010-24	TIE, cable .....	A/R
13	D2-010-14	BOSS, slider .....	2
14	D6-010-25	BOLT, allen, M8x6 .....	2
15	D2-010-17	SLIDER, large .....	1
16	D2-010-15	STOPPER, slider, large .....	1
17	D6-010-17	BOLT, allen, M8x15 .....	2
18	D6-010-09	WASHER, lock, M8 .....	2
19	D2-031-08	HOLDER, slider .....	1
20	D6-010-22	BOLT, allen, M12x35 .....	3
21	D6-010-21	WASHER, lock, M12 .....	3
22	D6-010-16-1	SCREW, phillips, M5x6 (stainless) .....	3
23	D2-010-03-1	SHROUD, elevation, exterior, .....	1
24	D2-010-04-1	SHROUD, elevation, middle .....	1
25	D2-031-07	SHROUD, elevation, inner .....	1
26	D6-010-19-1	SCREW, phillips, M5x10 (plated) .....	4
27	D2-010-12-1	GASKET, shroud .....	1
	D4-031-57	ELEVATION CYLINDER ASSEMBLY .....	1
28	D2-010-06	•TUBE, elevation cylinder .....	1
29	D2-010-07	•ROD, elevation cylinder .....	1
30	D6-010-14	•O-RING, P-12 .....	1
31	D2-010-08	•PISTON, elevation cylinder (30mm) .....	1
32	D4-010-12	•O-RING, P-24, (30mm piston) .....	1
33	D2-010-09	•WASHER, elevation piston .....	1
34	D6-010-38	•BOLT, allen, M6x15 .....	1
35	D2-010-10	•CUSHION, rubber dropping .....	1
36	D4-010-15	•O-RING, AN6227-24 (30 mm piston) .....	1
37	D2-010-11-1	•SAUCER, elevation cylinder .....	1
38	D6-010-18	BOLT, cylinder saucer mtg., M8x25 .....	2
39	D4-010-32	PACKING, copper .....	A/R
40	D4-010-31	FITTING, flexible hose, short .....	1
41	D4-010-23	HOSE, flexible, elevation cylinder, (240mm) .....	1
42	D6-034-18	LABEL, top rotation handle .....	1
43	D6-034-19	LABEL, table top warning .....	1
44	D2-034-05	HANDLE, table top locking .....	1



Item	Part No.	Description	Qty.
	D5-031-74	PENDANT CONTROL ASSEMBLY .....	1
1	D6-010-57-1	•SCREW, pendant hook, M4 x 12 (plated) .....	3
2	D5-034-07	•HOOK, pendant .....	1
3	D5-034-09	•INSERT, pendant hook .....	1
4	D5-031-22	•COVER, rubber .....	1
5	D5-031-13-1	•STRAIN RELIEF, pendant end .....	1
6	D5-031-34	•INSERT, pendant hook .....	1
7	D5-030-23	•MICRO-SWITCH .....	A/R
8	D5-031-21	•GASKET, micro-switch plate .....	1
9	D5-031-20	•PLATE, micro-switch mounting .....	1
10	D5-031-07	•SPRING, pendant button .....	A/R
11	----	•BUTTON, pendant, (specify function & S.N.) .....	A/R
12	D5-030-48	•CHROME RING, indicator light .....	1
13	D5-030-43	•INDICATOR LIGHT, green .....	1
14	D6-010-109	•SCREW, M3x16 .....	6
15	D6-032-15	•SCREW, M3x10 .....	2
16	D5-031-12-1	•HOLDER, plastic button .....	1
17	D5-030-42	•WASHER, special .....	6
18	D6-010-10-9	•SCREW, phillips, M3x15 .....	6
19	D5-031-75	•FACE PLATE, pendant control .....	1
20	D6-010-80-1	•SCREW, phillips, M3x6 .....	4
21	D5-031-13	•CORD, pendant control .....	1
22	D6-010-24	•TIE, cable .....	1
23	D5-030-18	•COVER, cannon connector .....	1
24	D5-031-13-1	•STRAIN RELIEF, connector end .....	1
25	D5-030-21	•CONNECTOR, cannon, 19-pin, male .....	1
26	D6-010-57-1	SCREW, phillips, M4x10 (plated) .....	4
27	D5-030-20	CONNECTOR, cannon, 19-pin, female .....	1
28	D5-030-46	GASKET, connector .....	2
29	D6-032-10	SCREW .....	4
30	D5-032-20	COVER, auxillary base connector .....	1
31	D5-131-01	CONNECTOR, 8-pin, female .....	2
32	D5-131-02	CONNECTOR, 8-pin, male .....	2
33	D5-030-03	CONNECTOR, 2-pin, female .....	A/R
34	D5-030-02	CONNECTOR, 2-pin, male .....	A/R
35	D5-032-27	CONNECTOR, 15-pin, female (CN-20) .....	1
	D5-032-73	WIRE HARNESS, relay box to riser cord .....	1
36	D5-032-28	CONNECTOR, 16-pin, female (CN-7) .....	1
37	D5-131-03	CONNECTOR, 16-pin, female (CN-6) .....	1
38	D5-032-10	CONNECTOR, 20-pin, female (CN-8) .....	1
39	D6-010-70	BOLT, allen, M5x10 .....	2
40	D5-032-30	RELAY BOX .....	1
41	D5-032-14	CONNECTOR, 5-pin, female .....	1
42	D5-030-29	CAPACITOR, motor starting .....	1
43	D6-010-19	SCREW, phillips, M 5 x 10 .....	1
44	D5-034-31	BRACKET, capacitor .....	1
45	D5-030-05	CONNECTOR, 3-pin, female .....	1
46	D5-030-04	CONNECTOR, 3-pin, male .....	1
47	D5-030-02	CONNECTOR, 2-pin, male .....	A/R
48	D5-030-03	CONNECTOR, 2-pin, female .....	A/R
--	D5-032-00	AUXILLIARY BASE CONNECTOR KIT .....	NS

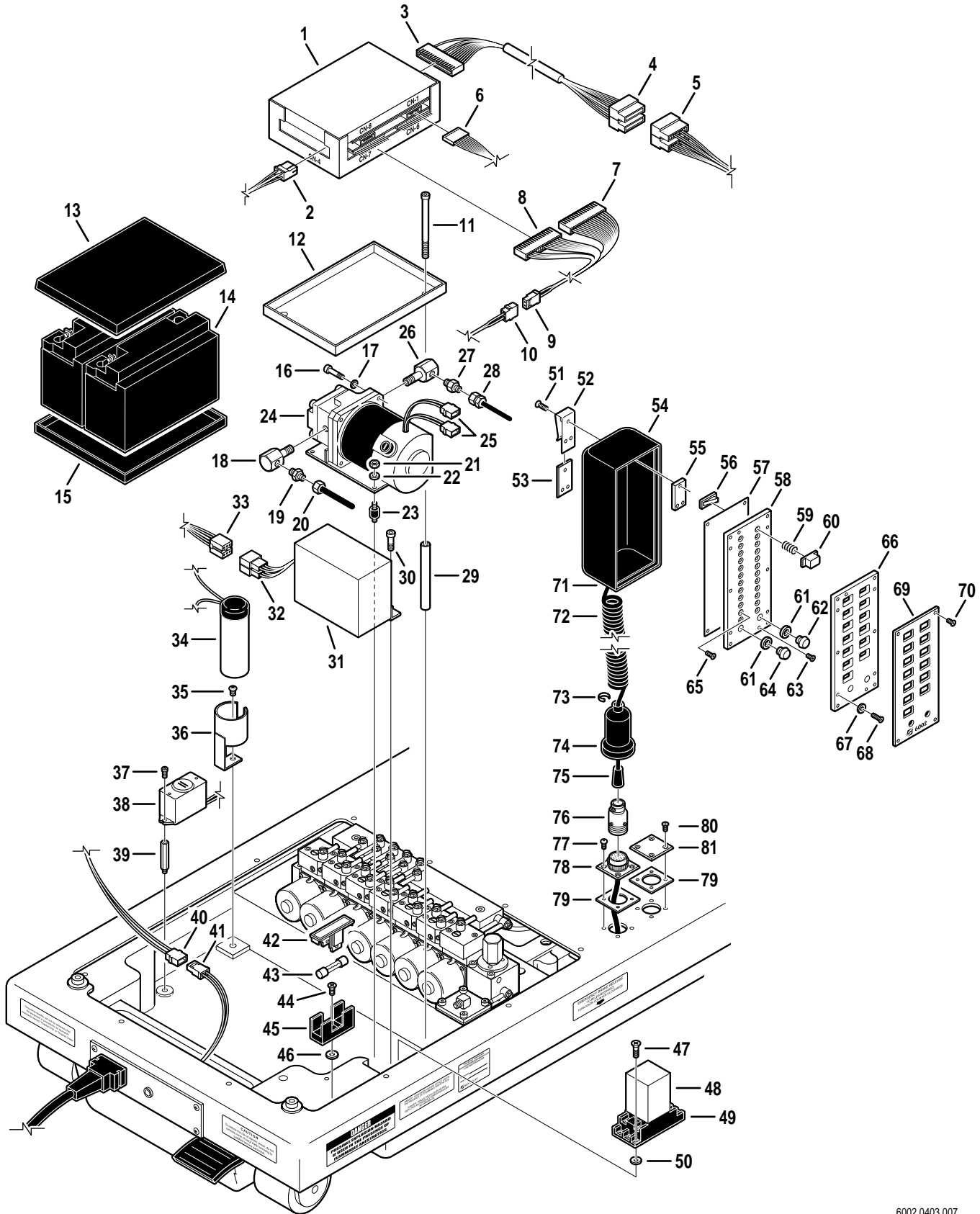

Item	Part No.	Description	Qty.
1	D5-032-31	RELAY BOX .....	1
2	D5-032-14	CONNECTOR, 5-pin, female (CN-4) .....	1
3	D5-032-27	CONNECTOR, 15-pin, female (CN-2) .....	1
	D5-032-73	WIRE HARNESS, relay box to riser cord .....	1
4	D5-131-02	CONNECTOR, 8-pin, male .....	1
5	D5-131-01	CONNECTOR, 8-pin, female .....	1
6	D5-032-10	CONNECTOR, 20-pin, female (CN-1) .....	1
7	D5-131-03	CONNECTOR, 16-pin, female (CN-6) .....	1
8	D5-032-28	CONNECTOR, 16-pin, female (CN-7) .....	1
9	D5-030-02	CONNECTOR, 2-pin, male .....	A/R
10	D5-030-03	CONNECTOR, 2-pin, female .....	A/R
11	D6-032-21	BOLT, allen, M5x105 .....	2
12	D1-032-23	TRAY, relay box .....	1
13	D1-032-21	COVER, battery .....	1
14	D5-032-43	BATTERY, 12V .....	2
15	D1-032-21	COVER, battery .....	1
16	D6-032-22	BOLT, allen .....	2
17	D6-060-16	WASHER, lock, M4 .....	2
18	D5-034-33	FITTING .....	1
19	D4-032-67	FITTING .....	1
20	D4-032-66	TUBE, suction .....	1
21	D6-010-76	NUT, M5 .....	4
22	D6-010-77	WASHER, lock, M5 .....	4
23	D4-031-65	ISOLATION MOUNT, motor .....	4
24	D5-034-32	PUMP/motor assembly .....	1
25	D5-030-03	CONNECTOR, 2-pin, female .....	A/R
26	D5-034-33	FITTING .....	1
27	D4-032-63	FITTING .....	1
28	D4-032-64	HOSE, flexible, pump return .....	1
29	D1-032-22	STAND-OFF .....	2
30	D6-010-70	BOLT, allen, M5x10 .....	2
31	D5-032-57	CHARGER, battery .....	1
	D5-031-50	•TRANSFORMER .....	1
32	D5-032-59	CONNECTOR, 6-pin, male .....	1
33	D5-032-60	CONNECTOR, 6-pin, female .....	1
34	D5-032-65	CAPACITOR, charging box .....	1
35	D6-010-19	SCREW, phillips, M 5x10 .....	1
36	D1-031-19	BRACKET, capacitor .....	1
37	D6-060-07	BOLT, allen, M 4x8 .....	2
38	D5-034-49	BUZZER, battery model .....	1
39	D1-032-22	STAND-OFF .....	2
40	D5-030-03	CONNECTOR, 2-pin, female .....	A/R
41	D5-030-02	CONNECTOR, 2-pin, male .....	A/R
42	D5-031-48	COVER, fuse holder .....	1
43	D5-032-42	FUSE, 15amp .....	1
44	D5-050-37	SCREW, phillips, M 4x8 .....	1
45	D5-031-49	FUSE HOLDER .....	1
46	D6-060-16	WASHER, lock, M4 .....	1
47	D6-031-45	SCREW, phillips, M4x15 .....	2
48	D5-032-51	RELAY, switch over .....	1



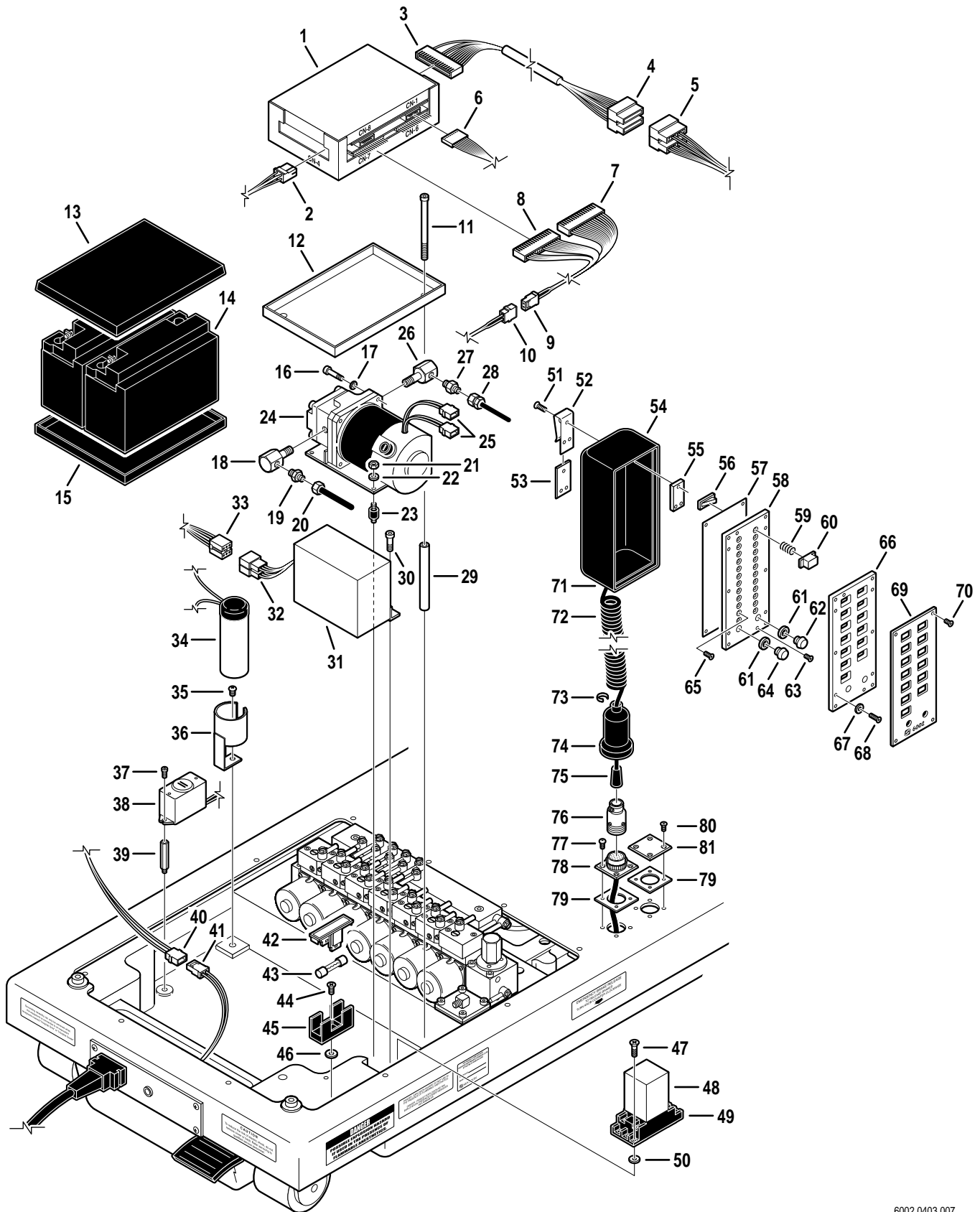

Item	Part No.	Description	Qty.
49	D5-032-56	TERMINAL STAND, relay .....	1
50	D6-060-16	WASHER, lock, M4 .....	A/R
	D5-031-80	PENDANT CONTROL ASSEMBLY .....	1
51	D6-032-33	•SCREW, pendant hook, M4 x 12 .....	3
52	D5-034-07	•HOOK, pendant .....	1
53	D5-034-09	•INSERT, pendant hook .....	1
54	D5-031-22	•COVER, rubber .....	1
55	D5-031-34	•INSERT, pendant hook .....	1
56	D5-030-23	•MICRO-SWITCH .....	A/R
57	D5-031-21	•GASKET, micro-switch plate .....	1
58	D5-031-20	•PLATE, micro-switch mounting .....	1
59	D5-031-07	•SPRING, pendant button .....	A/R
60	----	•BUTTON, pendant (specify button & S.N.) .....	A/R
61	D5-030-48	•CHROME RING, indicator light .....	2
62	D5-030-43	•INDICATOR LIGHT, green .....	1
63	D6-032-15	•SCREW, M3x10 .....	2
64	D5-030-43-1	•INDICATOR LIGHT, amber .....	1
65	D6-010-109	•SCREW, M3x16 .....	6
66	D5-031-56	•HOLDER, plastic button .....	1
67	D5-030-42	•WASHER, special .....	6
68	D6-010-10-9	•SCREW, phillips, M3x15 .....	6
69	D5-031-81	•FACEPLATE, pendant control .....	1
70	D6-010-80-1	•SCREW, phillips, M3x6 .....	4
71	D5-031-13-1	•STRAIN RELIEF, pendant end .....	1
72	D5-031-38	•CORD, pendant control .....	1
73	D6-010-24	•TIE, cable .....	1
74	D5-030-18	•COVER, cannon connector .....	1
75	D5-031-13-2	•STRAIN RELIEF, connector end .....	1
76	D5-032-38	•CONNECTOR, cannon, 24-pin, male .....	1
77	D6-010-57-1	•SCREW, phillips, M4x10 (plated) .....	4
78	D5-032-39	•CONNECTOR, 24-pin, female, cannon .....	1
79	D5-030-46	•GASKET, connector .....	2
80	D6-032-10	•SCREW .....	4
81	D5-032-20	•COVER, auxillary base connector .....	1

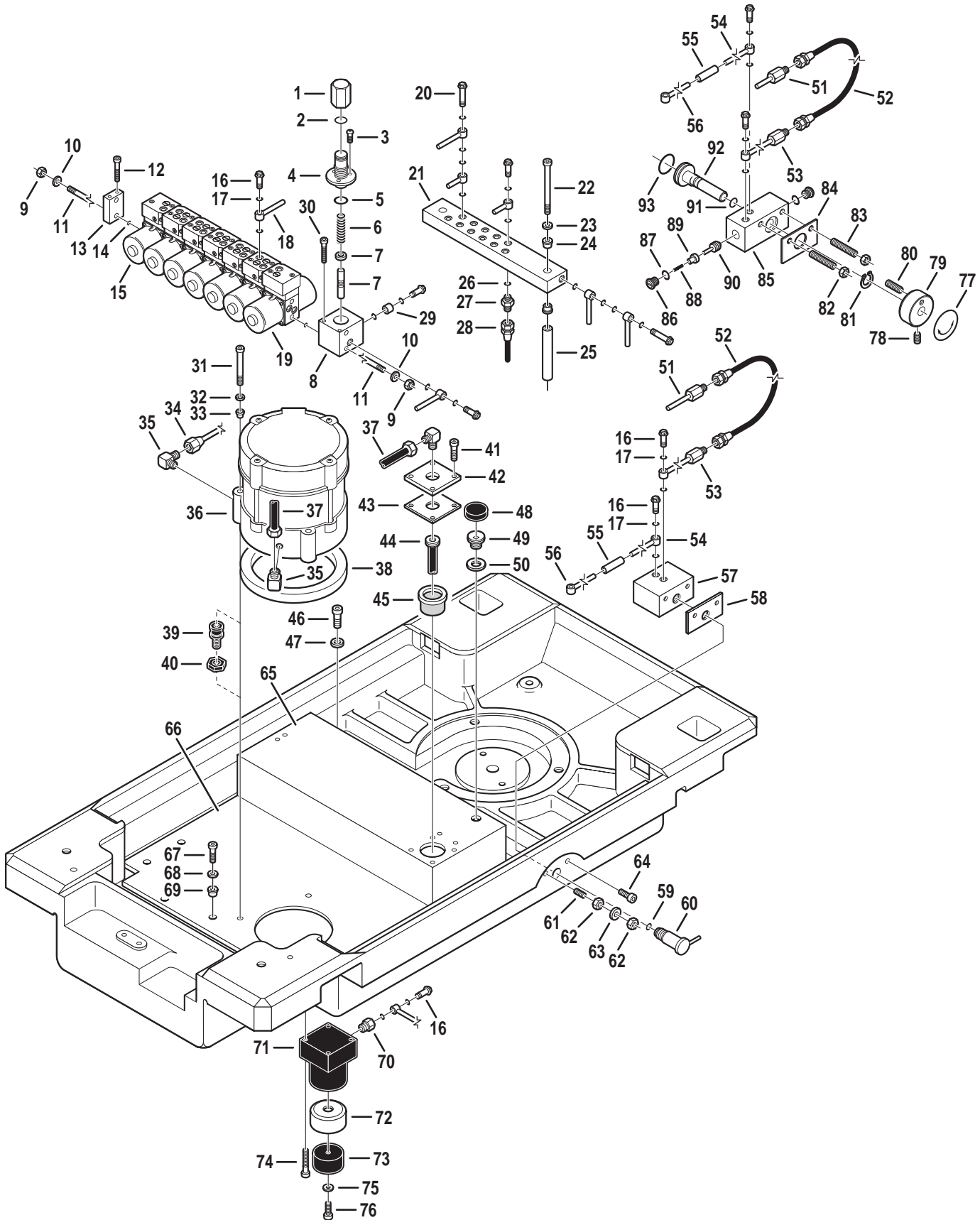

Item	Part No.	Description	Qty.
	D4-031-23	PRESSURE RELIEF VALVE .....	1
1	D4-034-20	•CAP, pressure relief valve .....	1
2	D4-031-67	•O-RING, P-10 .....	1
3	D6-034-14	•SCREW .....	3
4	D4-034-21	•BODY, pressure relief valve .....	1
5	D4-010-51	•O-RING, P-16 .....	1
6	D4-031-12	•SPRING .....	1
7	D4-031-23-4	•VALVE, relief, 5mm dia (steel) .....	1
8	D4-031-23-2	•HOUSING, relief valve (5mm dia valve) .....	1
9	D6-010-76	NUT, M5 .....	4
10	D6-010-77	WASHER, lock, M5 .....	4
11	D4-010-19	STUD, M5 .....	2
12	D6-010-64	BOLT, allen, M5x40 .....	2
13	D4-010-40	CAP, end .....	1
14	D4-010-52	O-RING, P-4 .....	A/R
15	D4-030-02	ELECTRO/MINI VALVE ASSEMBLY (4-way), 120VAC .....	A/R
	D4-032-60	ELECTRO/MINI VALVE ASSEMBLY (4-way), 24VDC .....	A/R
16	D4-010-24	BOLT, plumbing, M6 .....	A/R
17	D4-010-08	O-RING, P-7 .....	A/R
18	----	OIL LINE, specify function .....	A/R
19	D4-031-21	ELECTRO/MINI VALVE ASSEMBLY (3-way), 120VAC, elevation .....	A/R
	D4-032-92	ELECTRO/MINI VALVE ASSEMBLY (3-way), 120VAC, brake (Blue Dot) .....	A/R
	D4-032-59	ELECTRO/MINI VALVE ASSEMBLY (3-way), 24VDC, elevation .....	A/R
	D4-032-93	ELECTRO/MINI VALVE ASSEMBLY (3-way), 24VDC, brake (Blue Dot) .....	A/R
20	D4-010-26	BOLT, plumbing, M6 (long) .....	A/R
21	D4-032-23	TERMINAL, plumbing .....	1
22	D6-032-13	BOLT, allen, M6 x 140 .....	2
23	D6-010-85	WASHER, flat, M6 .....	2
24	D6-031-16	BUSHING, isolation .....	4
25	D4-032-81	STAND-OFF .....	2
26	D4-010-32	PACKING, copper .....	A/R
27	----	FITTING, flexible hose .....	A/R
28	----	HOSE, flexible (specify function) .....	A/R
29	D4-010-18	CAP, blind, M6 .....	1
30	D6-010-65	BOLT, allen, M5 x 35 .....	4
31	D6-031-22	BOLT, allen, M5 x 55 .....	3
32	D6-032-03	WASHER, flat, M5 (special) .....	3
33	D6-032-04	INSULATOR .....	3
34	----	HOSE, flexible (specify function) .....	A/R
35	D4-030-12	FITTING, hydraulic, 90° .....	A/R
36	D4-030-05	PUMP/MOTOR ASSEMBLY .....	1
37	D4-030-03	OIL LINE, supply .....	1
38	D1-030-14	PAD, insulating, motor .....	1
39	D6-131-02	RUBBER, antivibration .....	3
40	D6-131-03	NUT, antivibration rubber .....	3
41	D6-010-67	BOLT, allen, M5 x 15 .....	4
42	D4-031-14	COVER, oil tank .....	1
43	D4-031-13	GASKET, oil tank cover .....	1
44	D4-030-19	TUBE, induction .....	1
45	D4-031-11	STRAINER, oil .....	1
46	D6-010-51	BOLT, allen, M6 x 10 .....	2

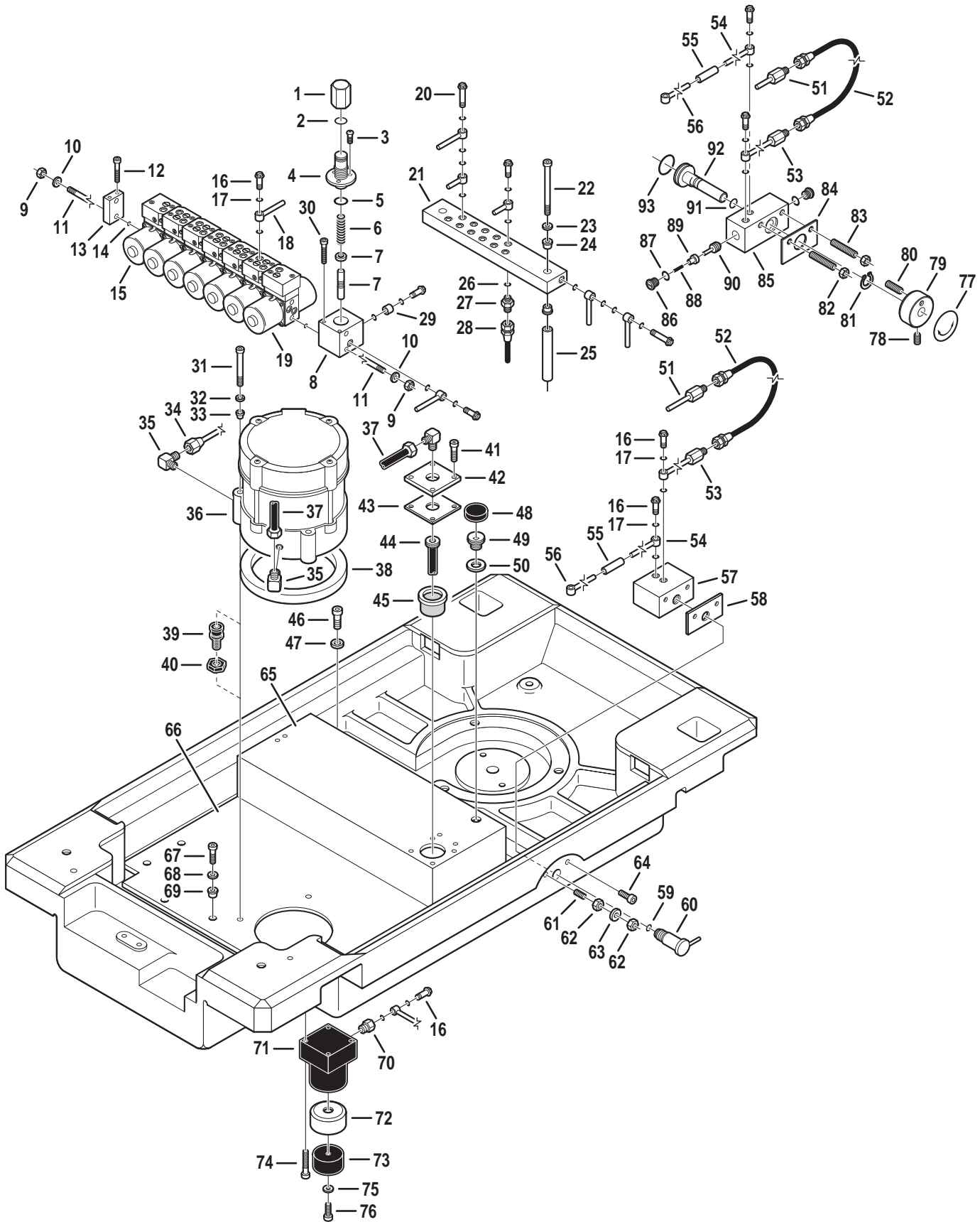

Item	Part No.	Description	Qty.
47	D6-010-85	WASHER, flat, M6 .....	2
48	D4-010-39	CAP, oil filler .....	1
49	D4-010-38	FITTING, oil filler .....	1
50	D4-010-37	GASKET, oil filler .....	1
51	D4-032-47	OIL LINE .....	1
52	D4-032-48	FLEXIBLE HOSE .....	1
53	D4-032-49	OIL LINE .....	1
54	D4-032-50	OIL LINE .....	1
55	D4-032-51	FLEXIBLE TUBE .....	1
56	D4-032-52	OIL LINE .....	1
	D4-032-45	EMERGENCY BRAKE RELEASE ASSEMBLY .....	1
57	D4-032-24-1	•BLOCK, emergency brake release .....	1
58	D4-032-46	•SPACER .....	1
59	D4-010-52	•O-RING, P-4 .....	1
60	D4-032-25	•HANDLE, emergency brake release .....	1
61	D6-032-41	SCREW, set .....	1
62	D6-010-41	NUT, M6 .....	2
63	D6-010-40	WASHER, M6 .....	1
64	D6-010-30	BOLT, allen, M6 x 20 .....	A/R
65	D4-034-22	RESERVOIR, oil tank .....	1
66	D4-034-23	PLATE, oil tank receiving .....	1
67	D6-010-30	BOLT, allen, M6 x 20 .....	A/R
68	D6-031-15	WASHER, M6 .....	A/R
69	D1-031-12	BUSHING, isolation .....	6
70	D4-065-01	FITTING, plumbing .....	A/R
71	D4-035-47	CYLINDER ASSEMBLY, brake .....	4
72	D4-031-95-1	SEAT, brake rubber .....	4
73	D4-031-96	PAD, brake, self-leveling, hard .....	2
	D4-031-97	PAD, brake, self-leveling, soft .....	2
74	D6-010-39	BOLT, allen, M6 x 45 .....	16
75	D6-010-36	WASHER .....	4
76	D6-010-30	BOLT, allen, M6 x 20 .....	4
	D4-017-15	EMERGENCY BRAKE RELEASE ASSEMBLY (ALTERNATE) .....	1
77	D6-017-29	•DECAL .....	1
78	D6-060-38	•SCREW, set, M5 x 10 .....	1
79	D6-017-30	•KNOB .....	1
80	D6-010-87	•SCREW, set, M6 x 20 .....	1
81	D6-017-31	•RING, retaining .....	1
82	D6-010-41	•NUT, hex, M6 .....	2
83	D6-035-06	•SCREW, set, M6 x 25 .....	2
84	D6-017-32	•SPACER .....	1
85	D4-017-16	•BLOCK, emergency brake release .....	1
86	D6-017-34	•PLUG, cap .....	2
87	D4-010-08	•O-RING, P-7 .....	2
88	D6-017-33	•SPRING .....	1
89	D4-017-17	•VALVE .....	1
90	D4-017-18	•PILOT PLUNGER .....	1
91	D4-010-08	•O-RING, P-7 .....	1
92	D4-017-19	•PLUNGER .....	1
93	D4-041-15	•O-RING, P-18 .....	1

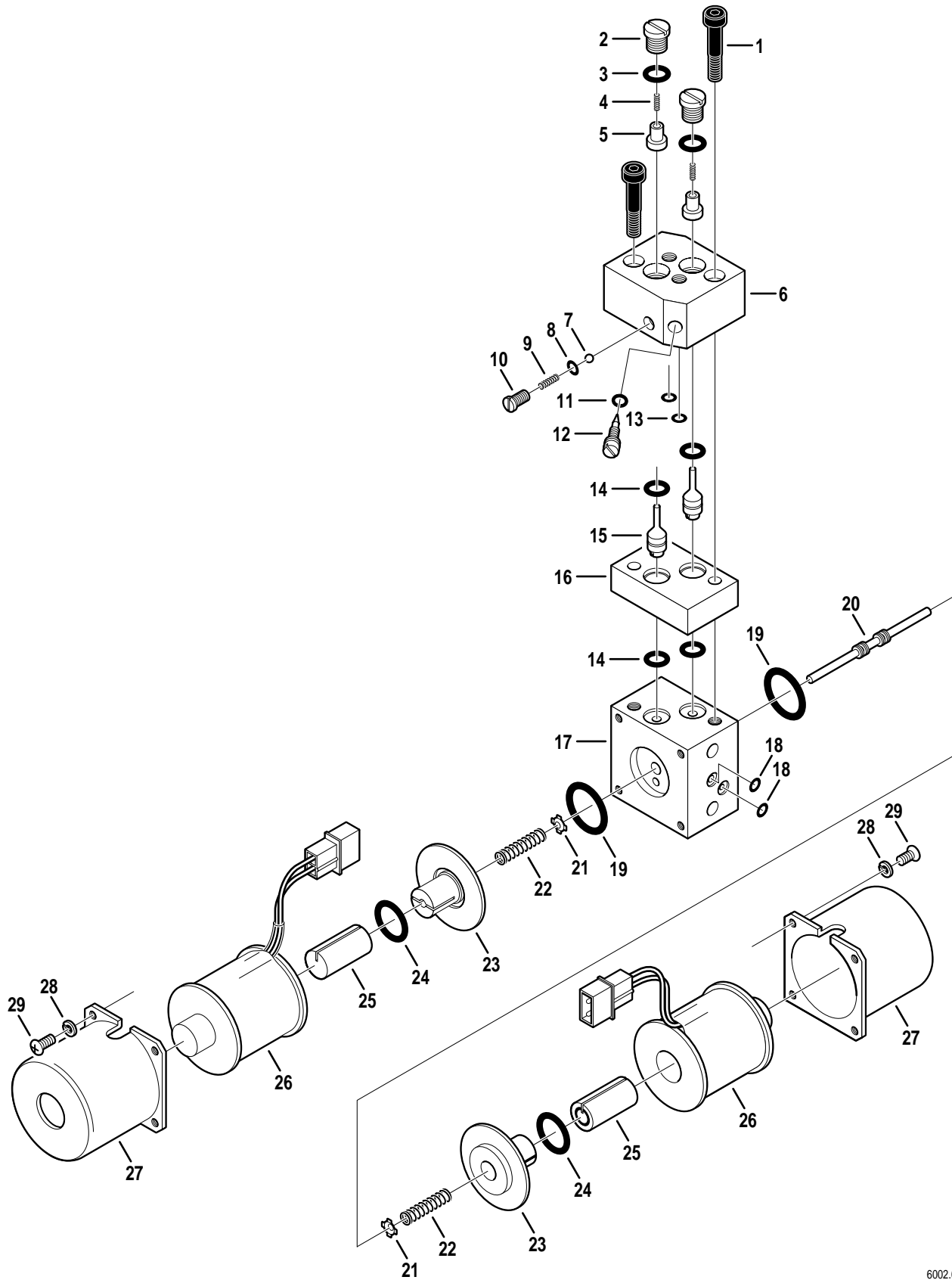

Item	Part No.	Description	Qty.
1	D6-010-65	BOLT, allen, M5x35.....	2
2	D4-010-41	PLUG, cap .....	A/R
3	D4-010-08	O-RING, P-7 .....	A/R
4	D4-010-42	SPRING, return .....	A/R
5	D4-010-25	VALVE, non-return .....	A/R
6	D4-010-43	VALVE BLOCK, 4-way .....	A/R
	D4-010-23	VALVE BLOCK, 3-way .....	A/R
7	D4-034-25	BALL, check .....	A/R
8	D4-050-12	O-RING, P-5 .....	A/R
9	D4-034-26	SPRING .....	A/R
10	D4-034-27	PLUG .....	A/R
11	D4-010-20	O-RING, P-3 .....	A/R
12	D4-010-44	VALVE, needle, speed control .....	A/R
13	D4-010-19	O-RING, P-6 .....	A/R
14	D4-010-01	O-RING, P-8 .....	A/R
15	----	PILOT PLUNGER (not available separately) .....	A/R
16	----	VALVE BLOCK (not available separately) .....	A/R
17	----	VALVE BLOCK (not available separately) .....	A/R
18	D4-010-52	O-RING, P-4 .....	A/R
19	D4-010-51	O-RING, P16 .....	A/R
20	----	SPOOL VALVE (not available separately) .....	A/R
21	D4-034-28	RETAINER, spool valve .....	A/R
22	D4-034-29	SPRING, return, spool valve .....	A/R
23	D4-034-30	GUIDE, bushing .....	A/R
24	D4-010-14	O-RING, P-12 .....	A/R
25	D4-034-31	PLUNGER, spool valve .....	A/R
26	D5-030-34	SOLENOID, 120VAC .....	A/R
	D5-031-35	SOLENOID, 24VDC .....	A/R
27	D5-034-37	HOUSING, solenoid .....	A/R
28	D6-010-78	WASHER, lock, M3 .....	8
29	D6-010-79	SCREW, phillips, M3x5 .....	8



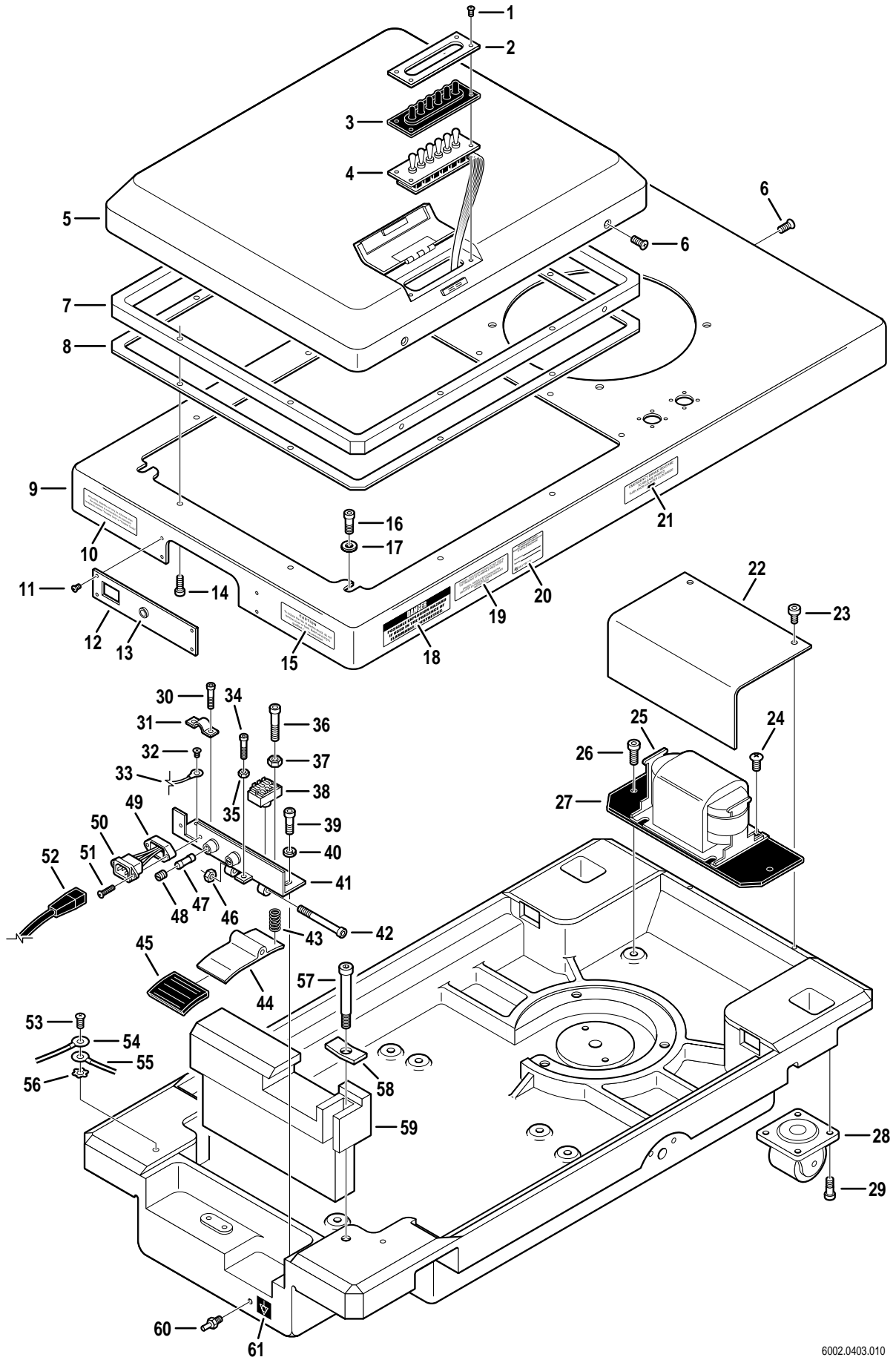

Item	Part No.	Description	Qty.
1	D6-035-04	SCREW, phillips, M4x8, button head .....	4
2	D5-034-38	FACEPLATE, switch, 6 switch .....	1
3	D5-034-39	COVER, switch assembly .....	1
4	D5-034-40	SWITCH PLATE ASSEMBLY .....	1
--	D5-034-41	•SWITCH, toggle, 2 position .....	6
5	D1-131-01	COVER, service access (6002B model) .....	1
	D1-131-02	COVER, service access (6002 model) .....	1
6	D6-035-08	SCREW, phillips, M4 x 8, flat head .....	5
7	D1-031-37	FRAME .....	1
8	D1-032-10	GASKET .....	1
9	D1-032-11	HOUSING, base .....	1
10	D6-031-29	DECAL, grounding reliability .....	1
11	D6-032-08	SCREW, allen, M4 x 6 (black) .....	4
12	D1-032-13	PLATE, fuse cover, (6002B model) .....	1
	D1-032-12	PLATE, fuse cover, (6002 model) .....	1
13	D5-031-53	LIGHT, indicator, (6002B model) .....	1
14	D6-010-67	BOLT, allen, M5 x 15 .....	10
15	D6-031-30	DECAL, caution, electric shock .....	1
16	D6-010-51	BOLT, allen, M6 x 10 .....	2
17	D6-010-85	WASHER, flat, M6 .....	2
18	D6-031-43	DECAL, danger, explosion hazard 1 .....	1
19	D6-011-32	DECAL, danger, explosion hazard 2 .....	1
20	D6-011-34	DECAL, radiation performance standard 21CFR .....	1
21	D6-031-56	DECAL, emergency brake release .....	1
22	D1-032-16	COVER, transformer .....	1
23	D6-050-36	BOLT, allen, M5 x 8 .....	2
24	D6-032-17	SCREW, phillips .....	2
25	D5-032-58	TRANSFORMER, battery charger .....	1
26	D6-032-18	BOLT, allen .....	2
27	D1-032-17	PLATE, transformer mounting .....	1
28	D1-010-30	CASTER. 105H-P .....	4
29	D6-010-96	BOLT, allen, M10 x 20 .....	16
30	D6-032-06	BOLT, allen, M4 x 20 .....	2
31	D5-032-37	RETAINER, power cord .....	1
32	D6-010-16	SCREW, phillips, M5 x 6 .....	1
33	----	WIRE, ground .....	A/R
34	D6-032-06	BOLT, allen, M4 x 20 .....	1
35	D6-010-59	NUT, M4 .....	1
36	D6-010-30	BOLT, allen, M6 x 20 .....	2
37	D6-010-41	NUT, M6 .....	2
38	D5-032-55	SWITCH, main power .....	1
39	D6-010-51	BOLT, allen, M6 x 10 .....	3
40	D6-010-40	WASHER, lock, M6 .....	3
41	D5-032-52-3	BRACKET, on/off switch .....	1
42	D6-032-09	BOLT, allen, M5 x 50 .....	1
43	D6-032-12	SPRING, (#89) .....	1
44	D5-032-53-1	SWITCH PEDAL, on/off switch .....	1
45	D5-032-54	COVER, switch pedal .....	1
46	D6-010-76	NUT, M5 .....	1

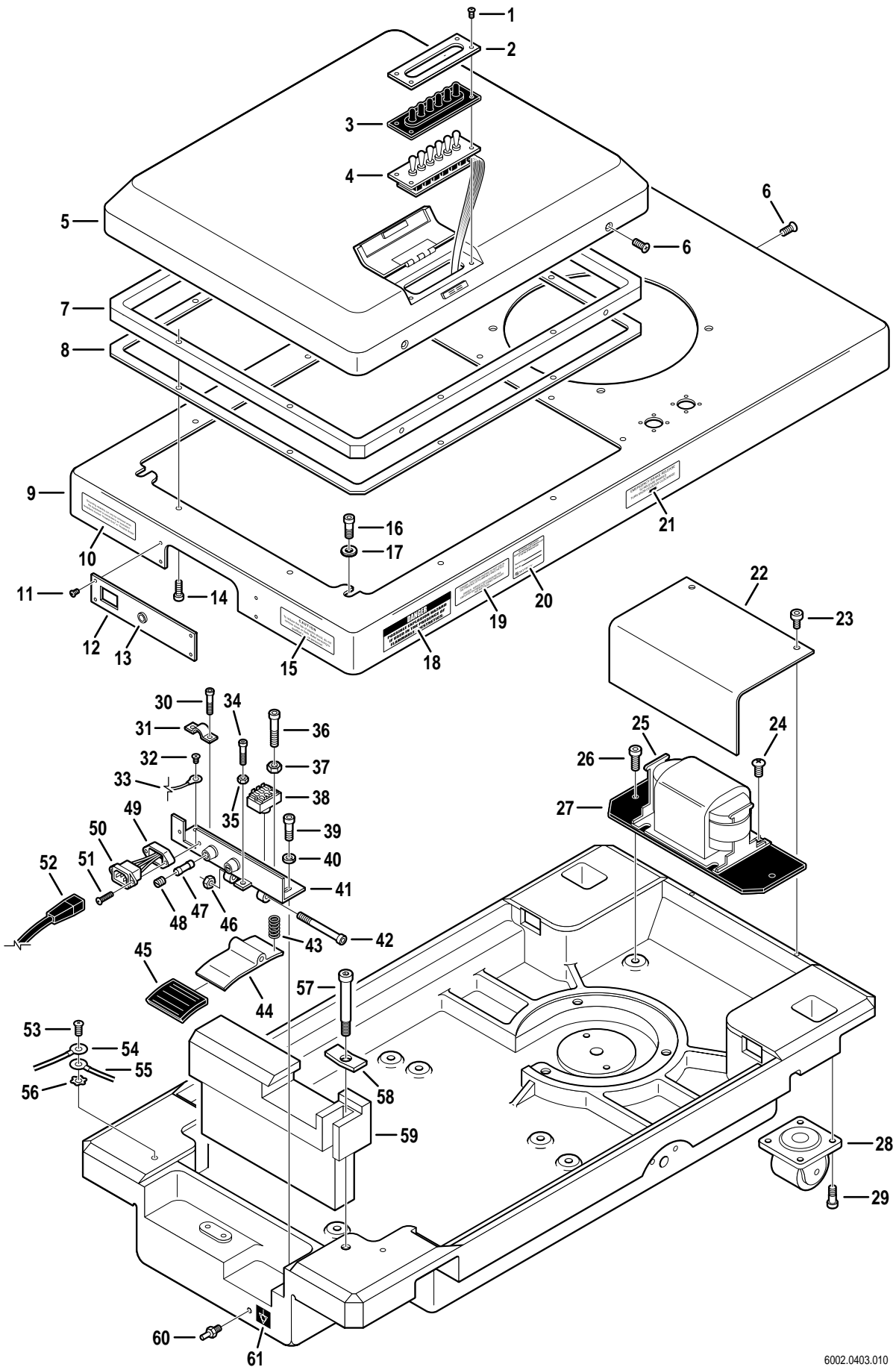

Item	Part No.	Description	Qty.
47	D5-032-41	FUSE, 10A.....	2
48	D5-032-74	FUSE HOLDER, 250V, 15A .....	2
49	D5-031-54-2	SPACER, power cord connector .....	1
50	D5-031-54-1	CONNECTOR, power cord .....	1
51	D6-032-10	SCREW, M3 x 20 .....	2
52	D5-031-08	POWER CORD ASSEMBLY .....	1
53	D6-010-16-1	SCREW, phillips, M5 x 6 (plated) .....	1
54	----	WIRE, ground .....	A/R
55	----	WIRE, ground .....	A/R
56	D6-034-16	WASHER, star, M5 .....	1
57	D6-031-14-1	BOLT, allen, M8 x 55 .....	1
58	D6-034-15	BRACING .....	1
59	D1-034-06	BALANCE WEIGHT .....	1
60	D6-034-20	EQUALIZATION TERMINAL .....	1
61	D6-034-21	LABEL, equalization terminal .....	1

---

Item	Part No.	Description	Qty.
	6-050-02	GAUGE, oil pressure .....	A/R
	D6-010-89	GREASE, slider .....	2.8 oz
	D6-010-90	OIL, hydraulic .....	Qt
	D4-011-02	HOSE, hydraulic, specify length .....	A/R
	D4-011-03	FITTING, hydraulic hose end .....	A/R

---



5000 36th Street S.E. • Grand Rapids, MI 49512  
1.800.SKYTRON • 1.616.957.0500 • FAX 1.616.957.5053



***ELITE SERIES SURGICAL TABLES***  
***MAINTENANCE MANUAL***

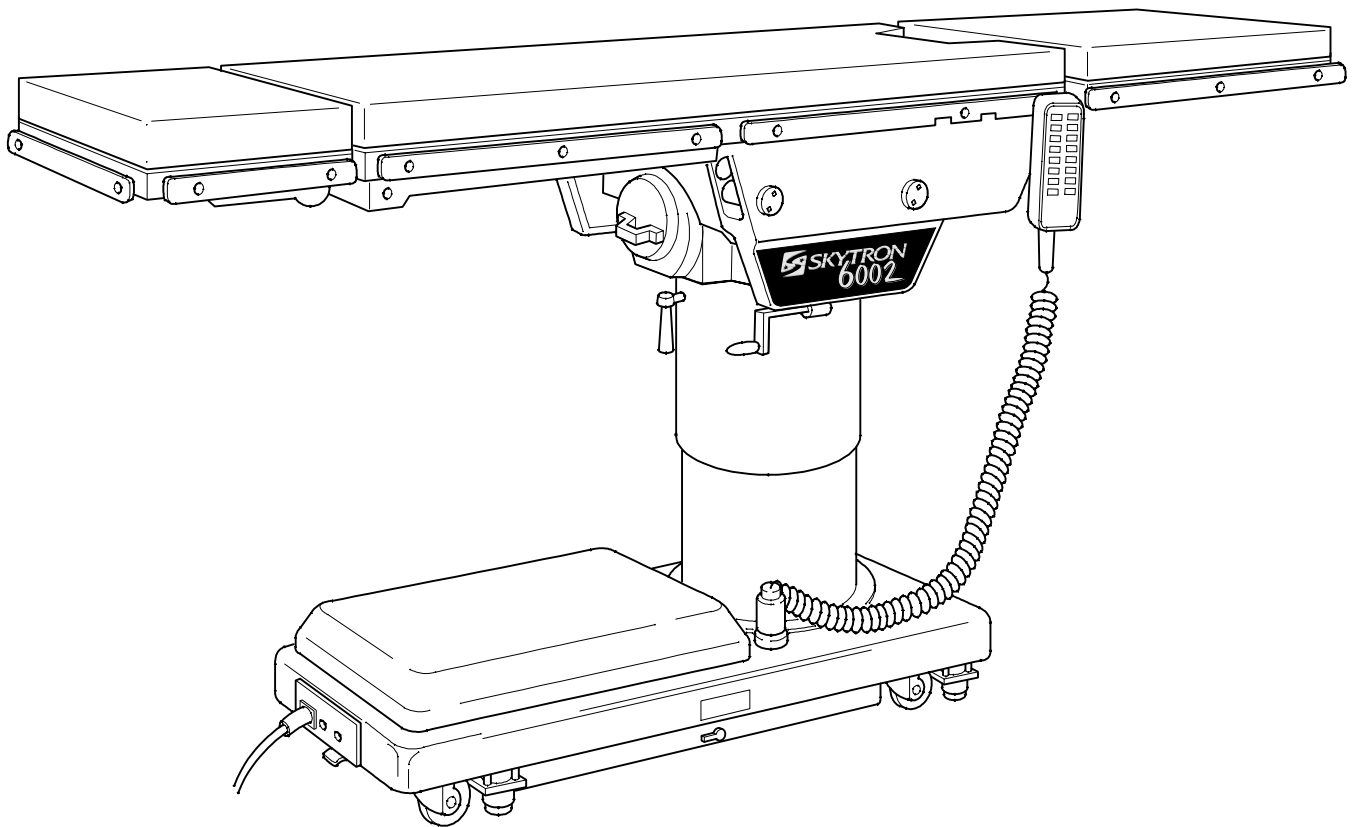

***MODEL ELITE 6002***  
***INCLUDING BATTERY MODELS***

# Table of Contents

SECTION I HYDRAULIC SYSTEM .....	1
1-1. General.....	1
1-2. Component Operation .....	2
a. Motor/Pump Operation .....	2
b. Pressure Relief Valve .....	2
c. Mini-Valves .....	3
d. Mini-valve in Neutral Position .....	3
e. Mini-Valve Right Port Activated .....	4
f. Mini-Valve Left Port Activated .....	4
g. Hydraulic Cylinders (Slave Cylinders) .....	5
h. Elevation Cylinder Return Circuit .....	6
i. Brake System.....	7
j. Emergency Brake Release .....	8
k. Flex/Reflex System .....	8
1-3. Hydraulic Adjustments .....	9
a. Fluid Level. ....	9
b. Bleeding The Hydraulic System .....	9
c. Pressure Relief Valve .....	9
d. Speed Controls.....	9
SECTION II MECHANICAL TABLE ADJUSTMENTS .....	11
2-1. Back Section Gear Mesh Adjustment .....	11
2-2. Hydraulic Cylinder Adjustment .....	11
a. Back Section .....	11
b. Leg Section .....	11
SECTION III HYDRAULIC TROUBLESHOOTING .....	12
3-1. Precautions .....	12
3-2. Troubleshooting Notes .....	12
3-3. ELEVATION DIAGNOSIS CHART .....	13
3-4. TRENDELENBURG DIAGNOSIS CHART .....	14
3-5. LATERAL - TILT DIAGNOSIS CHART .....	15
3-6. FLEX SYSTEM DIAGNOSIS CHART .....	16
3-7. BACK SECTION DIAGNOSIS CHART .....	17
3-8. LEG SECTION DIAGNOSIS CHART .....	18
3-9. BRAKE CIRCUIT DIAGNOSIS CHART .....	19
3-10. Flexible Hose Identification and Placement .....	20

REV 8/05

Although current at time of publication, SKYTRON's policy of continuous development makes this manual subject to change without notice.



# Table of Contents (continued)

SECTION IV ELECTRICAL SYSTEM.....	22
4-1. General.....	22
4-2. Components .....	22
4-3. Battery Model Components .....	22
SECTION V ELECTRICAL SYSTEM TROUBLESHOOTING .....	23
5-1. Troubleshooting Notes .....	23
5-2. Main Switch .....	23
5-3. Pendant Control .....	24
5-4. Relay Box.....	25
5-5. Solenoids.....	27
5-6. Motor/Pump Assembly .....	29
5-7. Return To Level Micro-Switches .....	31
5-8. Troubleshooting .....	31
SECTION VI -6002B- BATTERY MODEL, ELECTRICAL TROUBLESHOOTING.....	36
6-1. General.....	36
6-2. Troubleshooting Notes .....	36
6-3. Main Switch .....	37
6-4. Batteries .....	37
6-5. Battery Charging Box/AC120V Transformer .....	38
6-6. Switch-Over Relay .....	39
6-7. Pendant Control .....	40
6-8. Auxiliary Switches .....	42
6-9. Relay Box.....	43
6-10. Main Wire Harness Continuity Tests.....	45
6-11. Solenoids.....	46
6-12. Motor/Pump Assembly .....	47
SECTION VII ELECTRICAL SYSTEM ADJUSTMENTS .....	48
7-1. Relay Box Adjustments Models 6002 & 6002B.....	48



**WARNING**



Indicates a possibility of personal injury.

**NOTE**

Indicates important facts or helpful hints.



**CAUTION**



Indicates a possibility of damage to equipment.

## **BASIC RECOMMENDED TOOLS:**

1/8". 1/4" STRAIGHT BLADE SCREWDRIVERS  
#2 PHILLIPS SCREWDRIVER  
HYDRAULIC PRESSURE GAUGE SKYTRON P.N. 6-050-02  
METRIC ALLEN® WRENCHES 1.5mm-8mm  
ADJUSTABLE CRESCENT WRENCH  
DIGITAL VOLTMETER, TRUE RMS  
METRIC OPEN END WRENCHES 7mm-18mm  
LEVEL (CARPENTERS)

## **BASIC RECOMMENDED MAINTENANCE PROCEDURES**

The basic items notes below should be inspected at a minimal interval period of 6 months (dependant on usage). For optimal usage, safety and longevity of the product, have it serviced only by an authorized Skytron representative with authentic Skytron replacement parts.

- Check Power Cord (if applicable)
- Check Pendant Control (if applicable)
- Check Oil Level in Reservoir
- Check For Hydraulic Leaks
- Check All Table Functions
- Check Velcro
- Inspect Leg and Head Section detachment mechanisms for proper operation
- Lubricate Elevation Slider Assembly with SKYTRON Slider Grease P/N D6-010-89
- Tighten X-Ray Top Stand-Offs, Use Loc-tite
- Lubricate Casters
- Check brake pads for wear and inspect brake cylinders for proper operation.
- Inspect Articulating Joints
- Inspect Table Tops
- Check Operational Times and Pressure Values
- Check Pressure Relief Valve Setting
- Check Side Rails
- Check Lateral Tilt Housing Bolts



Only facility-authorized SKYTRON trained, maintenance personnel should troubleshoot the SKYTRON 6002 Surgical Table. Trouble shooting by unauthorized personnel could result in personal injury or equipment damage.

How to contact us:  
Skytron  
5000 36th St. SE, Grand Rapids, MI 49512  
PH: 1-800-759-8766 (SKY-TRON)  
FAX: 616-957-5053

---

## EQUIPMENT LABELS AND SPECIFICATIONS

---



INDICATES DANGEROUS VOLTAGE, 120 V, 60 Hz

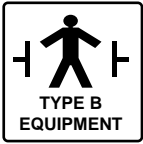

CLASS I DEFIBRILLATION PROOF, TYPE B EQUIPMENT- IPX4 RATED.  
INTERNALLY POWERED EQUIPMENT



PROTECTIVE GROUNDING.  
IN ORDER TO ENSURE PROPER GROUNDING RELIABILITY,  
THIS TABLE MUST BE CONNECTED TO A PROPERLY GROUNDED  
HOSPITAL GRADE OUTLET.



CONNECTION FOR NEUTRAL CONDUCTOR SUPPLIED



UNIT TO BE USED ONLY IN SPECIFIED ENVIRONMENTAL CONDITIONS  
TEMPERATURE: 15° - 30° C (60° -85° F)  
HUMIDITY: 30% - 60% RELATIVE HUMIDITY, NON CONDENSING



AC VOLTAGE

10A

FUSE (2) 10 AMP FAST ACTING

**IPX4**

ENCLOSURE CLASS

**V**

VOLTAGE RATING OF THE UNIT

**A**

AMPERAGE RATING OF THE UNIT

**HZ**

FREQUENCY OF THE UNIT



ATTENTION, CONSULT MANUAL FOR FURTHER INSTRUCTIONS.  
INDICATES SPECIAL USER ATTENTION.

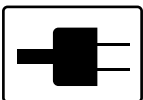

POWERED BY AC VOLTAGE

---

## BATTERY MODELS

---

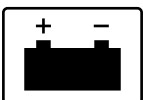

POWERED BY BATTERY

**BATTERY TYPE:** SEALED

LEAD ACID 12V, VALVE REGULATED  
16AH, 10HR (530W/10MIN)

**FUSE:** 15A 15 AMP FAST ACTING INTERNAL FUSE

## 6002 Series General Purpose Surgical Table Specifications

---

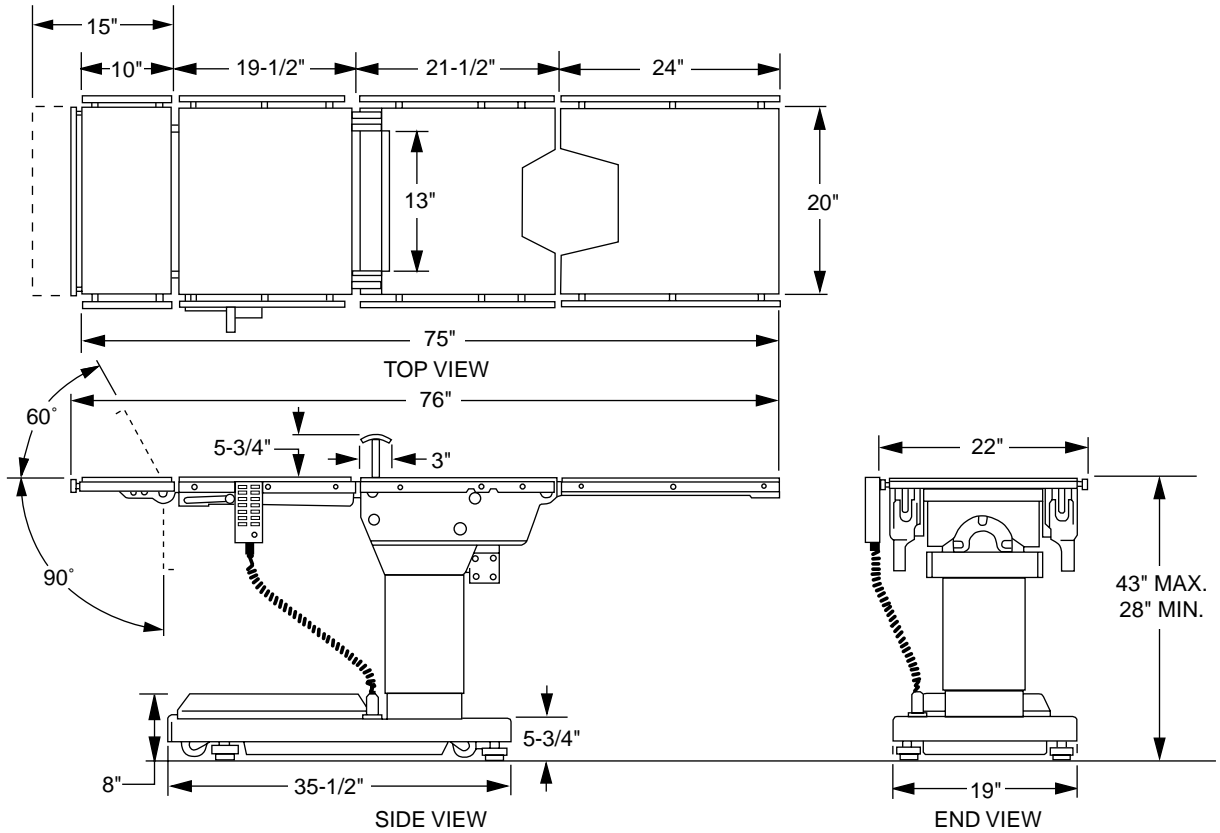

### Electrical Specifications

Power requirements	120 VAC, 60Hz, 300 Watts
Current Leakage	Less than 100 micro amps
Power Cord	15 feet w/hospital grade connector (removeable on battery model)

## SECTION I HYDRAULIC SYSTEM

### 1-1. General

#### Electro-Hydraulic System

The hydraulic system (with the exception of the hydraulic cylinders and hoses) is contained within the base of the table. The hydraulic valves and pump are electrically controlled by the use of a hand-held push button pendant control. The power requirements for the table are 120 VAC, 5 amp, 60 Hz.

The table contains the following components. Refer to the block diagram (figure 1-1) for relationship.

**a.** Oil Reservoir - Main oil supply. Approximately two quarts.

**b.** Motor/Pump Assembly - A positive displacement gear type pump provides the necessary oil pressure and volume.

**c.** Pressure Relief Valve - Provides an alternate oil path when the hydraulic cylinders reach the end of their stroke.

**d.** Electro/Hydraulic Mini-Valve Assemblies - These direct the fluid to the appropriate hydraulic cylinders.

**e.** Hydraulic Lines, Fittings, Connections - They provide a path for the hydraulic oil.

**f.** Hydraulic Cylinders - They convert the hydraulic fluid pressure and volume into mechanical motion.

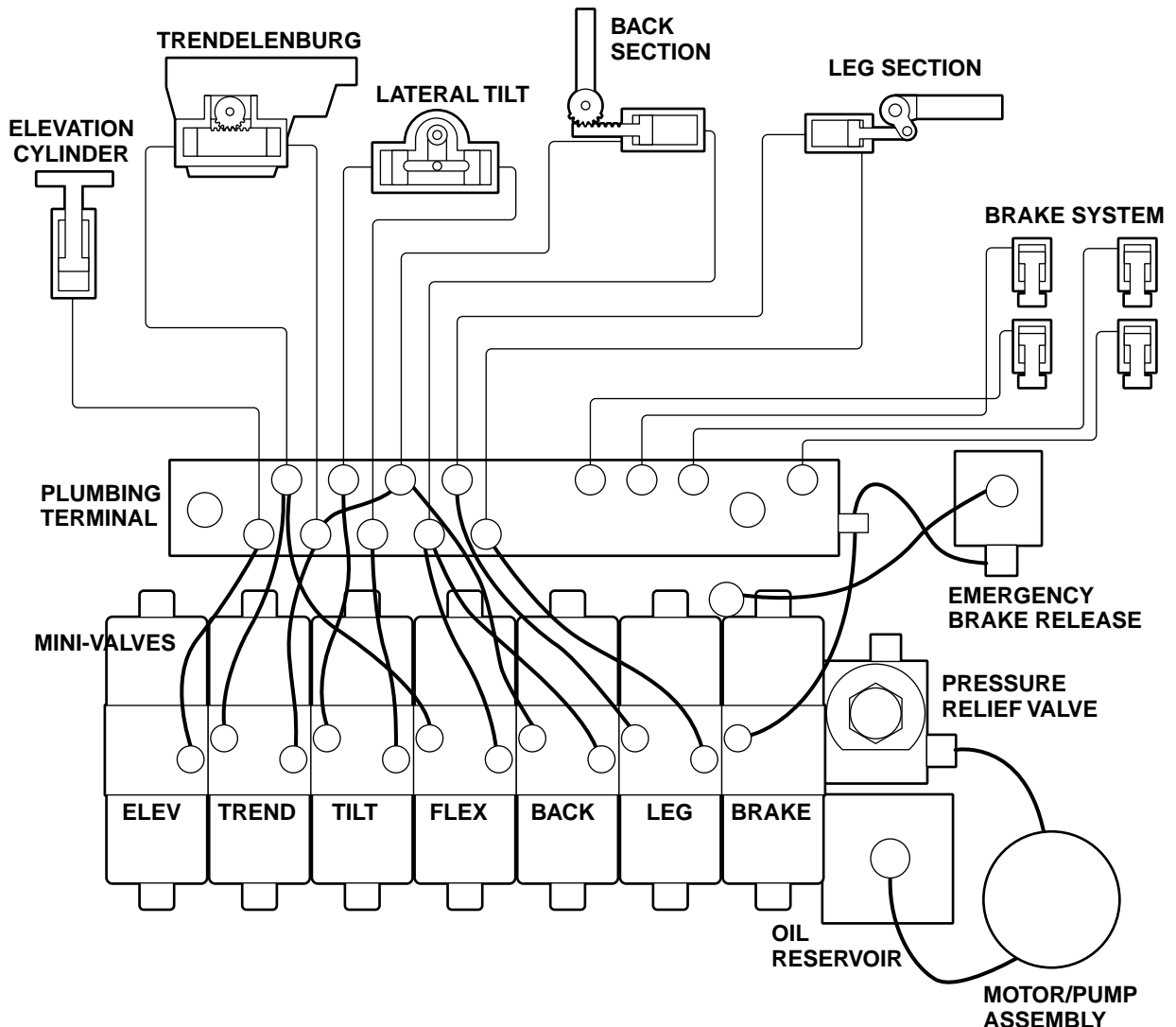

Figure 1-1. Hydraulic Block Diagram Model 6002

## 1-2. Component Operation

### a. Motor/Pump Operation

The motor/pump assembly is a gear type pump that provides the oil pressure and volume for the entire hydraulic system. The pump has an inlet side and an outlet side. The inlet side is connected to the reservoir which provides the oil supply. The reservoir has a very fine mesh screen strainer which prevents foreign material from entering the oil system.

The output line of the pump is connected to the main oil galley which is internal and common to all the hydraulic mini-valves and pressure relief valve. Also, common to the hydraulic mini-valves and pressure relief valve is an oil galley that internally connects to the oil reservoir to provide a return path for the hydraulic oil. See figure 1-2.

### b. Pressure Relief Valve

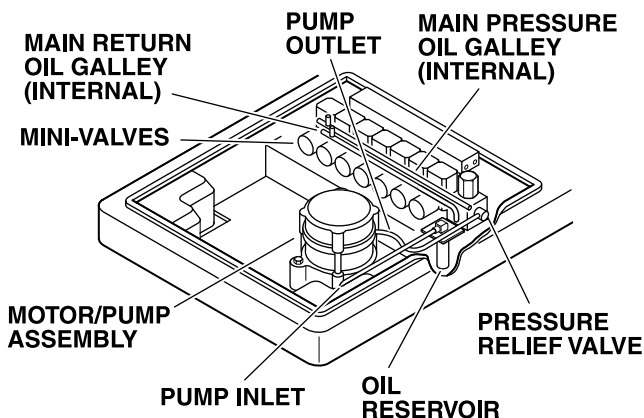

Figure 1-2.

This device provides an alternate oil path when the hydraulic cylinders reach the end of their stroke and the pump continues to run. If this path were not provided, the pump motor would stall because the oil cannot be compressed. The pressure relief valve is directly connected to the mini-valve bodies and shares both the common internal main pressure oil galley, and the return oil galley, that internally connect to the reservoir. See figure 1-3.

The main component of the valve is an adjustable spring loaded plunger that is pushed off from its seat by the oil pressure. The oil then flows back into the reservoir. See figure 1-4 Turning the adjustment nut clockwise increases the amount of oil pressure required to open the valve, and turning it counterclockwise decreases the amount of oil pressure. (See adjustment section for specification.)

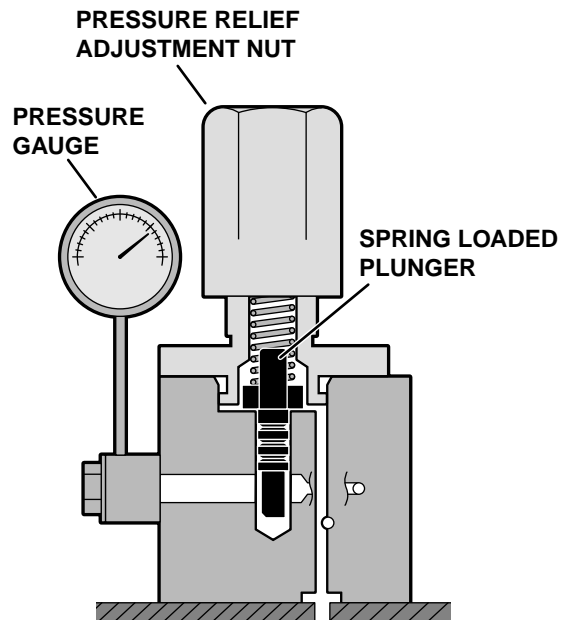

Figure 1-3. Pressure Relief Valve Not Functioning

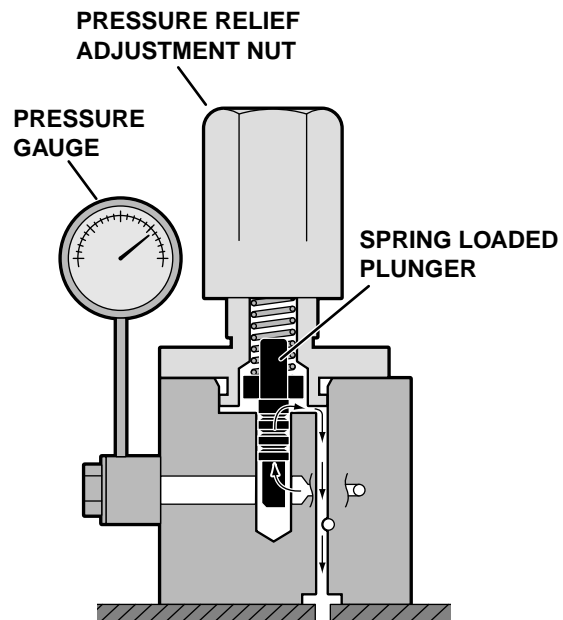

Figure 1-4 . Pressure Relief Valve Functioning

### c. Mini-Valves

The operation of the mini-valves is identical for all table functions except the elevation and Single Action Brake circuits. These two hydraulic circuits use a 3-way (single check valve) type mini-valve. All other functions use a 4-way (dual check valve) type mini-valve.

Either type mini-valve is controlled by two pushing type, electrically operated solenoids. The solenoids push the spool valve (located in the lower portion of the valve) one way or the other. This motion opens the main supply galley (which has pump pressure) allowing the oil to flow through the various parts of the mini-valve to the function. The spool valve also opens an oil return circuit which allows the oil to return to the oil reservoir.

The main components of the mini-valve and their functions are listed below:

1. Spool Valve - Opens the main oil galley (pump pressure) to either mini-valve outlet depending on which direction the spool valve is pushed. Also it provides a return path for the oil returning back into the reservoir.

2. Pilot Plunger - There are two plungers in a four-way mini-valve (one in a 3-way mini-valve), one under each check valve. The purpose of the pilot plungers is to mechanically open the return check valve allowing the oil to return back into the reservoir.

3. Check Valve - Two are provided in each four-way mini-valve to seal the oil in the cylinders and oil lines and prevent any movement of the table. One check valve is provided in a 3-way mini-valve.

4. Speed Adjustments - There are two speed adjustments in each mini-valve. They are needle valve type controls which restrict the volume of oil returning back into the reservoir, thereby controlling the speed of the table surface movement. A 3-way mini-valve has only one speed adjustment.

The speed controls are always located in the return oil circuit. This prevents uncontrolled movement of the piston in the slave cylinder due to one side of the piston being loaded with hydraulic pressure and the other side having no load.

Also, by using this control method, it doesn't matter what size cylinder and piston is used because the speed can be controlled by restricting the return oil. If the pump puts out more volume to a certain slave cylinder than the speed control is allowing to go back to the reservoir, the pressure relief valve provides an alternate path for the pump oil.

### d. Mini-Valve in Neutral Position

(No fluid flow) See figure 1-5.

1. Spool Valve Centered - This closes off both oil pressure and oil return galleys.

2. Pilot Plungers Both Closed - The pilot plungers control the opening of the check valves. If they are closed, the check valves must be closed.

3. Check Valves - Both check valves are closed trapping the oil in the cylinder and oil lines.

4. Speed Adjustment - When the mini-valve is in the neutral position, the speed adjustment does not affect anything because there is not any oil flow.

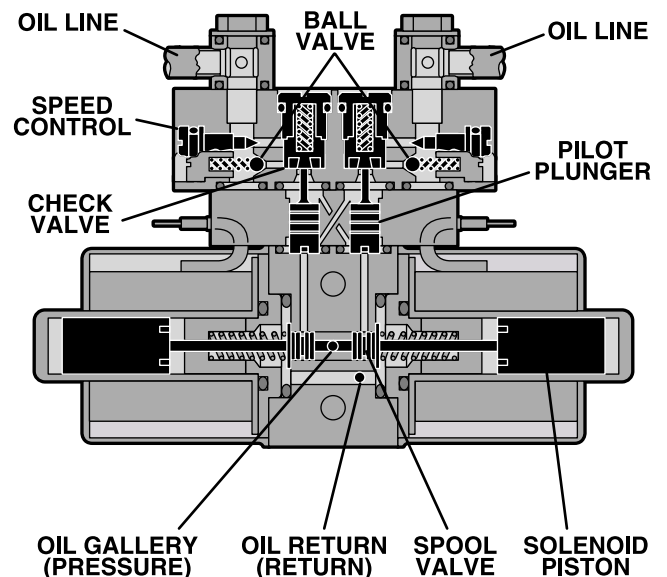
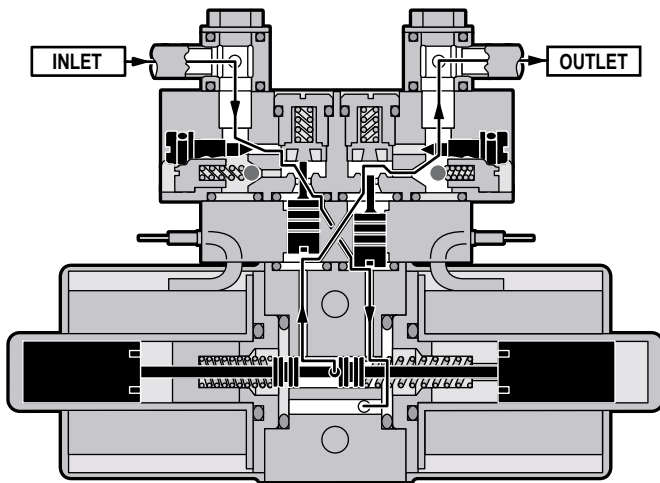

Figure 1-5. Mini-Valve in Neutral Position

### e. Mini-Valve Right Port Activated

(See figure 1-6)

Slave Cylinder Piston Moves to Left  
Right Mini-Valve Port is Supply Line  
Left Mini-Valve Port is Return Line



**Figure 1-6. Mini-Valve Right Port Activated**

1. Spool Valve - Pushed to the left by electric solenoid. This opens the internal oil pressure galley allowing the fluid to go through the check valve and on to the cylinder. Also, the spool valve opens the oil return line providing an oil path through the internal oil galley back to the reservoir.

2. Pilot Plunger Valve - Left pilot plunger valve is pushed up by the incoming oil pressure mechanically opening the check valve located above it in the return circuit. This action allows the oil from the left side of the slave cylinder to go back into the reservoir. The right pilot plunger valve is not affected in this operation mode.

3. Check Valves - Both check valves are opened in this operation mode. The right check valve is pushed open by the oil pressure created by the pump. The oil then continues to go through the lines and pushes the slave cylinder piston to the left. At the same time, the left check valve is held open mechanically by the pilot plunger providing a return path for the oil through the mini-valve back to the reservoir.

4. Speed Adjustment - The right speed control (output side) does not have any effect in this operation mode because the oil is routed around the speed adjustment through a by-pass valve and then to the output port. The left speed adjustment controls the speed of the table function by restricting the amount of oil going back into the reservoir.

### f. Mini-Valve Left Port Activated

(See figure 1-7.)

Slave Cylinder Piston Moves to Right  
Left Mini-Valve Port is Supply Line  
Right Mini-Valve Port is Return Line

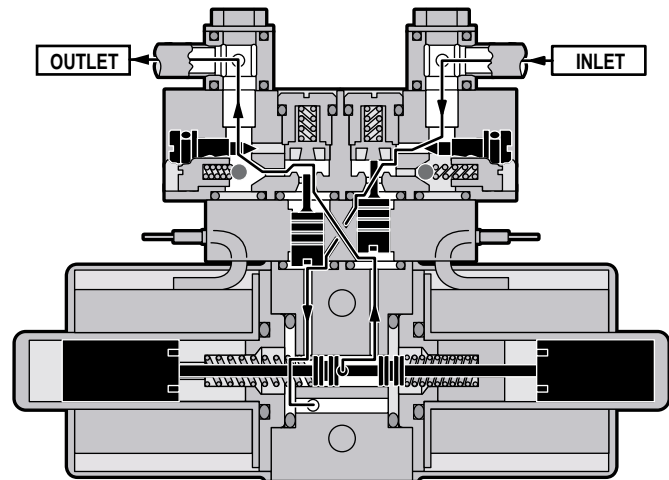

**Figure 1-7. Mini-Valve Left Port Activated**

1. Spool Valve - Pushed to the right by electric solenoid. This opens the internal oil pressure galley allowing the fluid to go through the check valve and on to the cylinder. Also, the spool valve opens the oil return line providing an oil path through the internal oil galley back to the reservoir.

2. Pilot Plunger Valve - Right pilot plunger valve is pushed up by the incoming oil pressure mechanically opening the check valve located above it in the return circuit. This action allows the oil from the right side of the slave cylinder to go back into the reservoir. The left pilot plunger valve is not affected in this operation mode.

3. Check Valves - Both check valves are opened in this operation mode. The left valve is pushed open by the oil pressure created by the pump. The oil then continues to go through the lines and pushes the slave cylinder piston to the right. At the same time, the right check valve is held open mechanically by the pilot plunger providing a return path for the oil through the mini-valve back to the reservoir.

4. Speed Adjustment - The left speed control (output side) does not have any effect in this operation mode because the oil is routed around the speed adjustment through a by-pass valve and then to the output port. The right speed adjustment controls the speed of the table function by restricting the amount of oil going back to the reservoir.



### g. Hydraulic Cylinders (Slave Cylinders)

There are several different types of hydraulic cylinders used in the table that activate the control functions. With the exception of the elevation and brake cylinders, all operate basically the same way. The control functions are listed below: (See figure 1-8.)

- Back Section--2, double action cylinders
- Leg Section--2, double action cylinders
- Trendelenburg--1, double action cylinder
- Lateral Tilt--1, double action cylinder
- Elevation--1, single action cylinder
- Brakes--4, single action cylinders

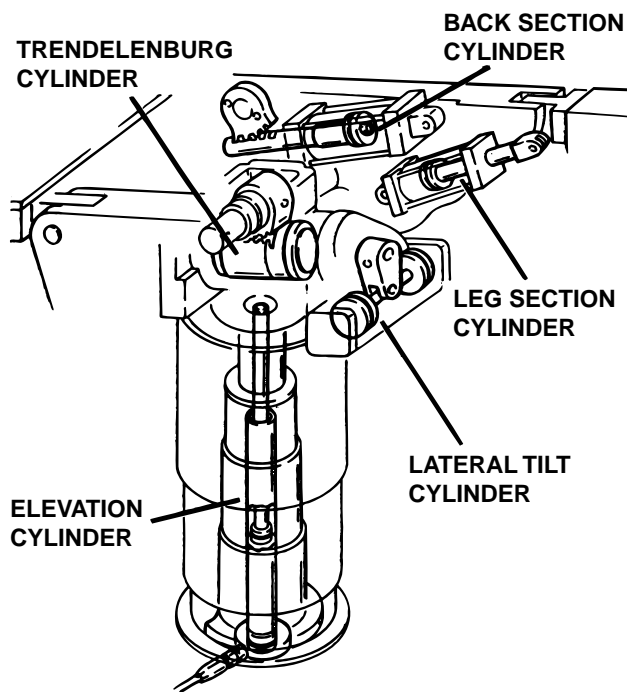

**Figure 1-8. Cylinder Placement**

1. Back Section and Leg Section Cylinders - The double action cylinders are closed at one end and have a movable piston with hydraulic fluid on both sides. Connected to this piston is a ram or shaft that exits out of the other end of the cylinder. Through the use of either a gear, or clevis and pin arrangement, this ram is connected to a movable table surface.

The movable surface can be moved one way or the other by pumping hydraulic fluid into the cylinder on either side of the piston. Obviously, if oil is pumped into one side of the cylinder, a return path must be provided for the oil on the other side. See figure 1-9.

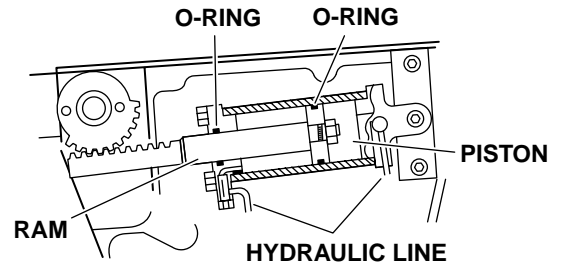

**Figure 1-9. Back Section Cylinder**

2. Trendelenburg Cylinder Assembly - This cylinder / piston arrangement has rack teeth cut into the top of each piston. These teeth mesh with a pinon gear that is connected directly to the table side frames. The pinon gear shaft and table side frames are supported by bearings at either side. When hydraulic fluid is pumped into one side of the cylinder, the pistons are pushed in one direction, moving the pinon gear and table side frames with them. Oil pressure can be applied to either side of the piston, making the table tilt end for end. See figure 1-10.

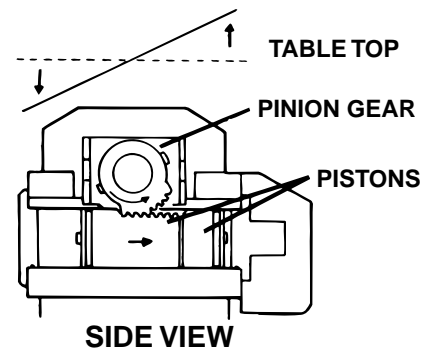

**Figure 1-10. Trendelenburg Cylinder Assy.**

In order to remove any looseness or play in the table top, the trendelenburg pistons are made in two pieces as shown in figure 1-11. This arrangement eliminates any gear lash between the piston teeth and the table pinon gear due to oil pressure always being present on both sides of the pistons.

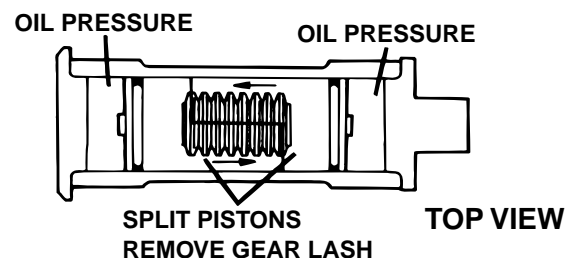

**Figure 1-11. Trendelenburg Cylinder Pistons**

3. Lateral Tilt Assembly - The lateral tilt assembly consists of two cylinders, pistons and connecting rods. The connecting rods attach to the lateral tilt lever which connects to the table side frames. When hydraulic fluid is pumped into one cylinder, the piston and connecting rod pushes the lateral tilt lever which tilts the table top to one side. To tilt the table top in the opposite direction, fluid is pumped into the opposite cylinder. See figure 1-12.

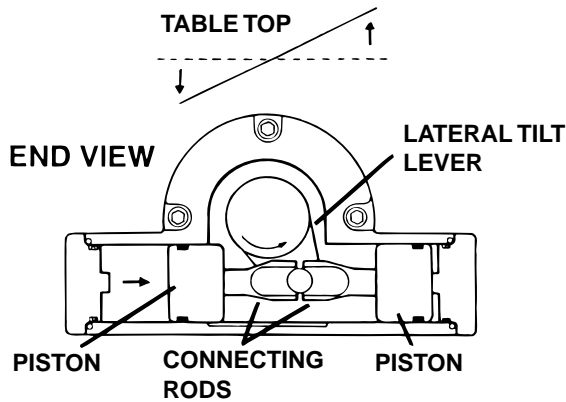
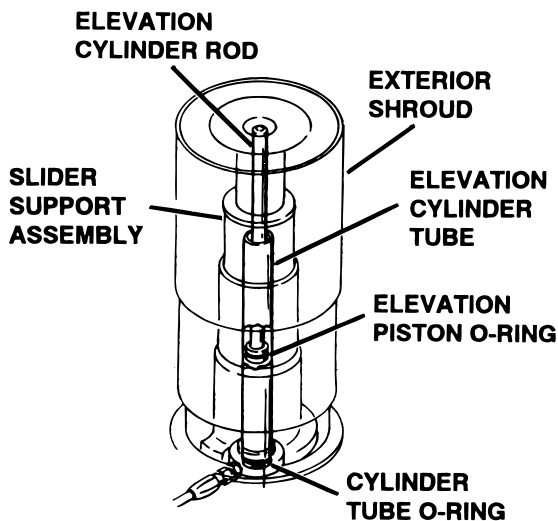

**Figure 1-12. Lateral Tilt Cylinder Assembly**

4. Elevation Cylinder - This single action cylinder does not have hydraulic fluid on both sides of the piston. It depends on the weight of the table top assembly to lower it.

The cylinder is set in the center of the elevation main column. The cylinder is elevated by the driven force of the oil pressure. When lowering, the oil that is accumulated in the cylinder is returned to the oil reservoir through the mini-valve due to the table top weight.

A slider support assembly is used to support the weight of the upper table section. A stainless steel shroud covers the flexible hydraulic hoses and slider. See figure 1-13.



**Figure 1-13. Elevation Cylinder Assembly**

5. Brake Cylinders - The brake cylinders are single action type similar to the elevation cylinder. The movable piston's ram is connected to a brake pad. See figure 1-14. Oil pumped into the top of the cylinder pushes the piston down raising the table base off its casters. An internal return spring on the bottom of the piston, pushes the piston up to return the oil through the mini-valve to the reservoir.

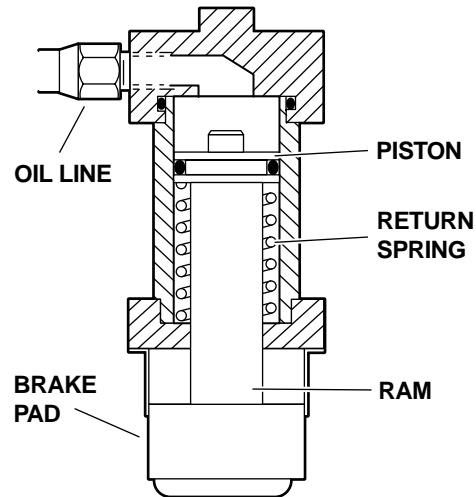
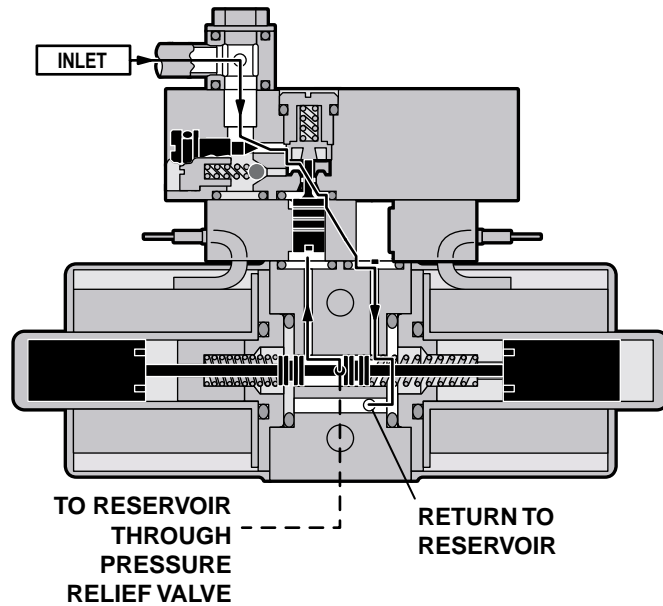

**Figure 1-14. Single Action Brake Cylinder**

#### **h. Elevation Cylinder Return Circuit**

Three-way (single check valve type) mini-valves control both the elevation and return circuits. The elevation circuit operation within the mini-valve is identical to the operation of the four-way valves previously described (inlet pressure opens the check valve allowing the oil to enter the cylinder). In the return position, inlet pressure pushes the pilot plunger up and opens the return check valve. See figure 1-15. The open check valve allows a path for the oil in the elevation cylinder to return to the reservoir. When the pilot plunger valve is opened, the continuing pump pressure opens the pressure relief valve which provides a return oil path to the reservoir.

The mini-valve used in the elevation circuit contains only one check valve (all four-way mini-valves use two check valves). The check valve is used to trap the oil in the elevation cylinder thereby supporting the table top. When the top is being lowered the check valve is mechanically held open by the pilot plunger through pump pressure.

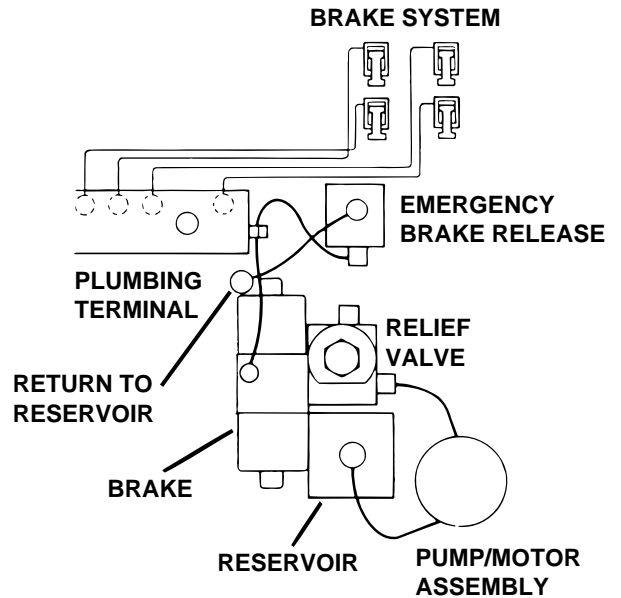

**Figure 1-15. Elevation Return Circuit**

### i. Brake System

The brake system consists of the following components: (figure 1-16)

1. Single action slave cylinders (4 each).
2. 3-way (single check valve type) mini-valve.
3. Manually controlled emergency brake release.
4. Plumbing terminal, flexible hoses, copper lines and "O" rings.
5. Portions of the electrical system.



**Figure 1-16. Brake System Block Diagram**

Each corner of the cast-iron table base has a hydraulic brake cylinder. These single action cylinders are hydraulically connected in parallel to the mini-valve and all four are activated together. It is normal for one corner of the table to raise before the others due to the weight distribution of the table.

An electronic timer in the relay box is activated when any function on the pendant control is pushed momentarily. The pump/motor and brake system mini-valve are activated and the brake cylinders are completely set. The electronic timer runs for approx. 8-10 seconds.

The brakes are released by pushing the BRAKE UNLOCK button momentarily. An electronic timer in the relay box activates the brake function hydraulic mini-valve and pump/motor.

When activated, the return hydraulic circuit operates similar to the elevation cylinder return circuit. Return springs inside the single action brake cylinders retract the brake pads and provide the pressure to return the hydraulic oil back to the reservoir. The electronic timer operates the return circuit for approximately 8-10 seconds.

## j. Emergency Brake Release

The emergency brake release is simply a manually operated bypass valve connected in parallel to the brake cylinders and the oil reservoir. See figure 1-17. When the valve is opened (turned counter-clockwise) a return circuit for the brake hydraulic fluid is opened. The return springs force the pistons up pushing the hydraulic oil back into the reservoir and retracting the brake pads.

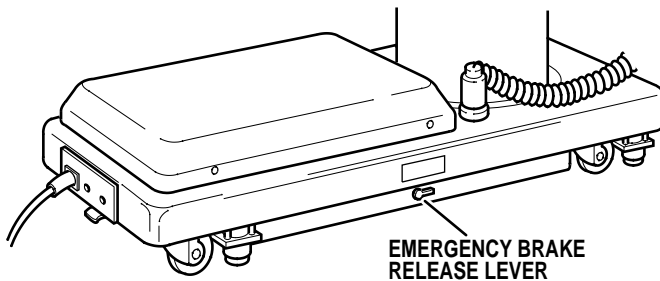

Figure 1-17.

### NOTE

- The emergency brake release valve must be tightened securely when not in use.
- If the emergency brake release valve has been operated, the UNLOCK button on the pendant control may have to be pressed before brakes will lock again.

If the emergency brake release valve is open or loose, two conditions could occur:

The brakes will release slowly- depending on how loose the valve is, this could take anywhere from a few minutes to several hours.

## k. Flex/Reflex System

The Flex/Reflex system used on the present tables incorporates an additional mini-valve (7 total) which connects the trendenburg and back section hydraulic systems in a series. When FLEX is activated by the pendant control, the Flex/Reflex mini-valve opens the oil pressure path to the Reverse Trendenburg piston. The return oil path from the trendenburg piston is routed through the back section cylinder to the mini-valve return port. See

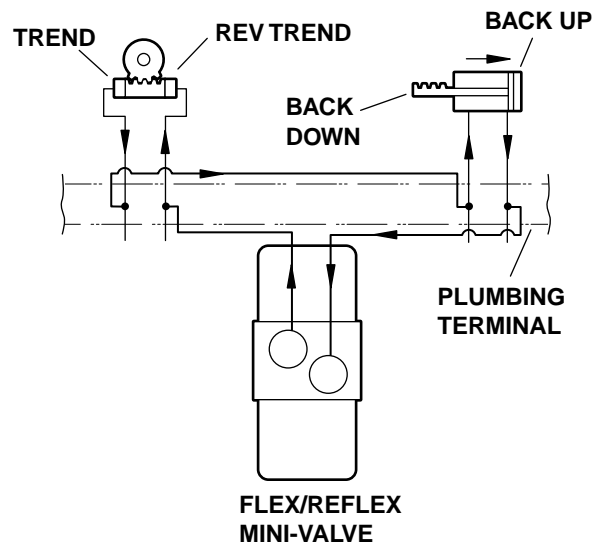

figure 1-18.

Figure 1-18. Flex/Reflex System

### 1-3. Hydraulic Adjustments

#### a. Fluid Level.

The fluid level should be approximately 1/2" below the filler hole or gasket surface. If additional fluid is needed, remove the filler vent cap with a phillips screwdriver and add fluid through this opening using a funnel. See figure 1-19.

#### NOTE

The elevation cylinder should be completely down and all the other control functions in their neutral position when checking oil level.

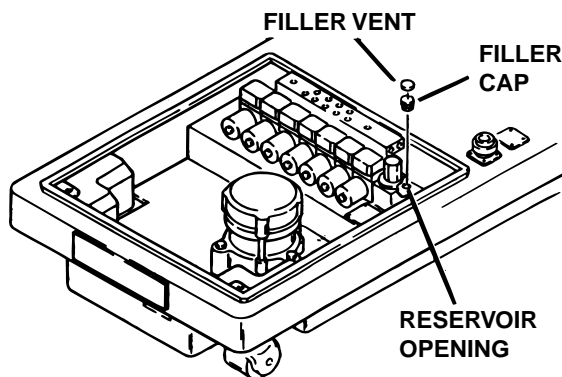

Figure 1-19.

The type of oil that should be used is Mobil DTE #25 or equivalent. This is a very high quality hydraulic oil. The table requires approximately two quarts of oil to operate properly.

#### b. Bleeding The Hydraulic System

To purge the air from the hydraulic system, operate each function back and forth at least two or three times.

#### NOTE

Whenever a hydraulic line or component is replaced, bleed the air out of the lines using the pump pressure before making the final connection. Then operate the function until it stalls in both directions.

#### c. Pressure Relief Valve

The pressure relief valve is adjusted by turning the adjustment nut until the desired pressure is reached.

To adjust:

1. Remove the blind cap and attach a hydraulic pressure gauge to the main oil galley using a 6mm plumbing bolt. See figure 1-20.

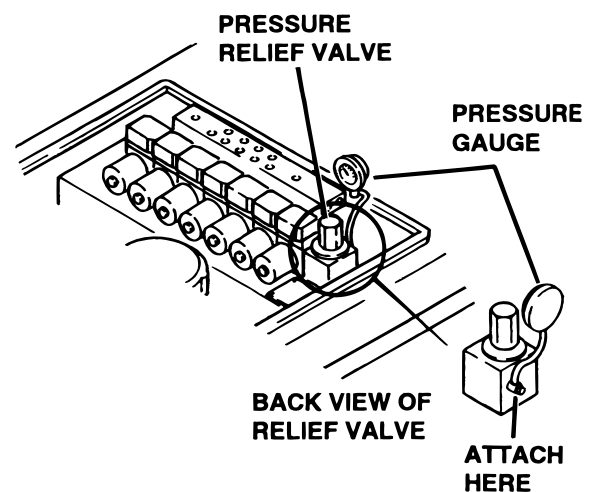

Figure 1-20.

2. Raise the table top until the piston reaches the end of its stroke and stalls. Observe reading on pressure gauge and turn the adjustment nut (clockwise to increase oil pressure, counterclockwise to decrease) until desired reading is obtained. Pressure should be 80KG/CM† -1138 PSI.

#### d. Speed Controls

The speed controls restrict the volume of oil returning back to the reservoir thereby controlling the speed of each control function.

All four-way mini-valves, have two speed controls located in the ends of each valve body. All three-way mini-valves have only one speed control.

One speed control adjusts one direction of a particular function and the opposite speed control adjusts the other direction. They are adjustable by using a small straight blade screwdriver and turning the adjustment screw clockwise to decrease the speed and counterclockwise to increase the speed. Refer to figure 1-21.

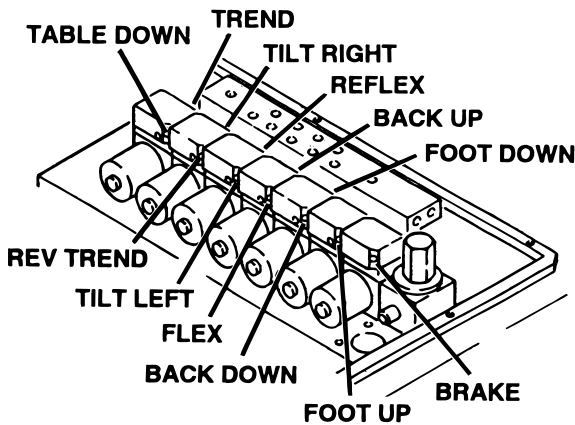

Figure 1-21.

Any control function should move in either direction at the same rate. If the rate of a certain function is too slow, open the speed control slightly and recheck. Use the second hand on a watch and time a particular function. Match that time in the opposite direction by opening or closing the speed control. Approximate operating times are as follows:

Lateral Tilt	7 seconds
Back Up	25 seconds
Back Down	15 seconds

A pressure gauge should be used to set the speed of the back section, trendelenburg and flex control functions.

To adjust:

1. Attach the pressure gauge onto the main oil galley as shown in figure 1-21.
2. The gauge should read the following values when operating the various control functions in either direction. Turn the speed controls until desired values are obtained.

Back Section	Up	65KG/CM $\ddagger$ -925PSI
	Dn	65KG/CM $\ddagger$ -925PSI
Trendelenburg	Up	65KG/CM $\ddagger$ -925PSI
	Dn	65KG/CM $\ddagger$ -925PSI
Flex		70KG/CM $\ddagger$ -995PSI
Reflex		70KG/CM $\ddagger$ -995PSI

#### NOTE

When adjusting Flex/Reflex speed controls, set Reflex last.

Elevation - There is not a speed adjustment for raising the table. The speed control will only affect the rate of descent and it should equal the rate of elevation.

## SECTION II MECHANICAL TABLE ADJUSTMENTS

### 2-1. Back Section Gear Mesh Adjustment

The gear mesh is adjusted by the use of an eccentric cam. This cam moves the gear teeth closer together to eliminate gear lash. This adjustment arrangement compensates for any wear between the gears that might occur.

To adjust:

Loosen the cam locking nut and allen set screw. Use a spanner wrench to rotate the eccentric cam. Use firm pressure on the spanner wrench. See figure 2-1. Tighten the locking nut and set screw when adjustment is complete.

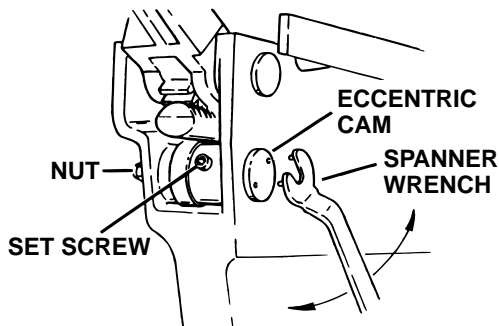

Figure 2-1. Eccentric Cam Adjustment

### 2-2. Hydraulic Cylinder Adjustment

Back & Foot / Leg Sections

The hydraulic cylinder rams that control both the back and foot / leg sections must move together so that these sections are not twisted when operated. This is accomplished by the use of eccentric cams that move the cylinder bodies fore and aft to adjust their effective stroke.

#### NOTE

Adjust gear mesh before adjusting eccentric cams for the back section.

#### a. Back Section

Position the back section all the way up until it stalls. Both sides of the back section should stop moving at the same time and should not show any signs of twisting.

Any twisting or flexing of the back section as it approaches the stalled position indicates that one of the cylinders is not reaching its fully extended position at the same time as the other. This condition would require an adjustment.

To adjust:

Loosen the cam locking nuts located inside the table side frames. Use a spanner wrench to turn the cylinder eccentric cams as required to shift either cylinder fore or aft as needed so no twisting or flexing of the back section is observed when it is stalled in the full up position. See figure 2-2.

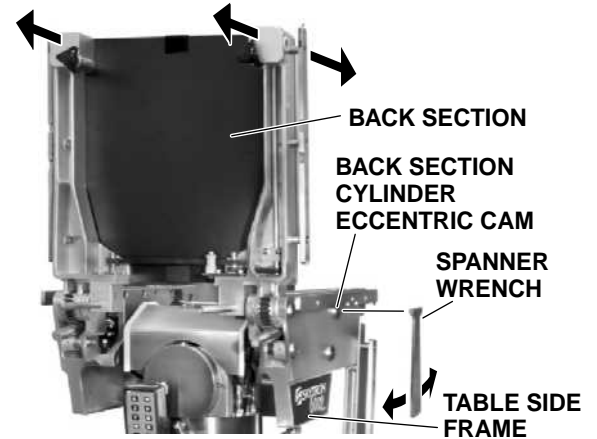

Figure 2-2. Back Section Adjustment

#### b. Leg Section

Position the leg section all the way up. Both sides of the leg section should stop moving at the same time and should not show any signs of twisting.

Any twisting or flexing of the leg section as it approaches the stalled position indicates that one of the cylinders is not reaching its fully extended position at the same time as the other and an adjustment is required.

To adjust:

Loosen the cam locking nuts located inside the table side frames. Use a spanner wrench to turn the cylinder eccentric cams as required to shift either cylinder fore or aft as needed so no twisting or flexing of the leg section is observed when it is stalled in the above horizontal position. Tighten locking nuts when proper adjustment is achieved. See figure 2-3.

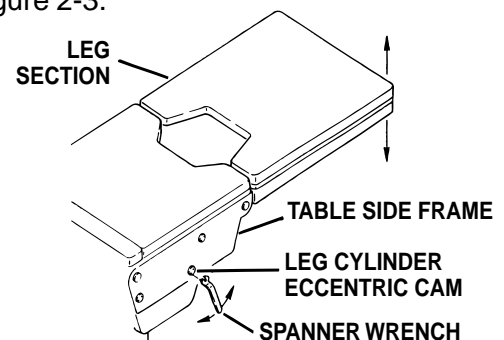

Figure 2-3. Leg Section Adjustment

## SECTION III HYDRAULIC TROUBLESHOOTING

### 3-1. Precautions

Before attempting to troubleshoot any hydraulic problem on the table, please read through the precautions and notes below.



#### CAUTION



When disconnecting any of the hydraulic lines, fittings, joints, hoses, etc., for the following control functions, be sure these table surfaces are in their down position or completely supported.

- Elevation
- Back Section
- Leg Section

When working on the trendelenburg or lateral tilt hydraulic circuits, be sure to support the table top. When working on the brake system make sure the brakes are completely retracted.



#### CAUTION



Failure to follow these precautions may result in an uncontrolled oil spray and damage to the table or personal injury.

### 3-2. Troubleshooting Notes

When troubleshooting a table malfunction, first determine the following:

1. Does the problem affect all control functions?
2. Does the problem affect only one control function?
3. If the problem affects one control function is it in both directions?
4. Is the problem intermittent?
5. Is the problem no movement of a table surface or does the table surface lose position?

Once the problem has been determined, concentrate on that particular hydraulic circuit or control function.

Listed below are the hydraulic components that are common with all hydraulic circuits. If there is a problem with any of them, it could affect all control functions.

1. Motor/Pump Assembly
2. Reservoir
3. Pressure Relief Valve
4. Certain Oil Lines and Galleys

If there was a problem in the following components, only one control function would normally be affected.

1. Mini-Valve
2. Slave Cylinder
3. Oil Lines

#### NOTE

Whenever a hydraulic line or component is replaced, bleed the air out of the lines using the pump pressure before making the final connection. After all connections are tight, cycle the control function back and forth two or three times to purge the remaining air from the system.



#### CAUTION



When installing new "O" rings use hydraulic oil to thoroughly lubricate the "O" rings and cylinder. Keep everything clean.

Each complete oil circuit is shown on the following pages. When troubleshooting a particular function, refer to the appropriate oil circuit diagram and the list of possible problems



### 3-3. ELEVATION DIAGNOSIS CHART

Problem	Reason
Table will not elevate properly	Pressure Relief Valve Not Set Properly Low on Oil Spool Valve Not Centered Defective Pump Defective Mini-Valve Defective Solenoid or Wiring Defective Relay Box or Pendant Control
Table will not descend properly	Incorrect Speed Adjustment Bad Check Valve Spool Valve Not Centered Galled Slider Assembly Defective Solenoid or Wiring Defective Relay Box or Pendant Control
Table loses elevation	Bad Check Valve Leaking Mini-Valve Loose Fittings, Joints, Hoses Leaking "O" Ring Inside Cylinder

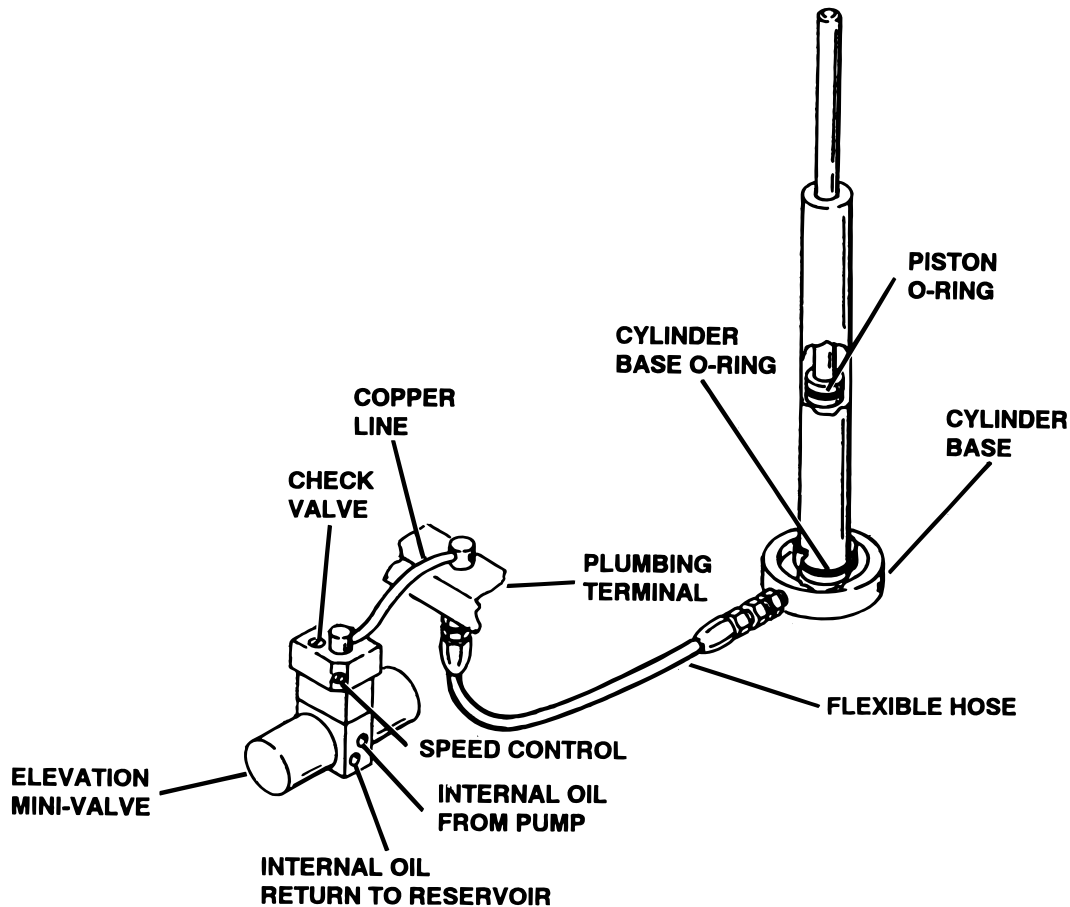

Figure 3-1. Elevation Circuit

### 3-4. TRENDELEBURG DIAGNOSIS CHART

Problem	Reason
Trendelenburg function moves improperly	Incorrect Speed Adjustment Spool Valve Not Centered Bad Check Valves Low on Oil Pinched Hose Defective Mini-Valve Pressure Relief Valve Not Set Properly Bad Solenoid or Wiring Defective Relay Box or Pendant Control
Trendelenburg function chatters or loses position	Defective or Dirty Check Valve Oil Leakage in Circuit Air Inside Cylinder Pinched Hose Low on Oil

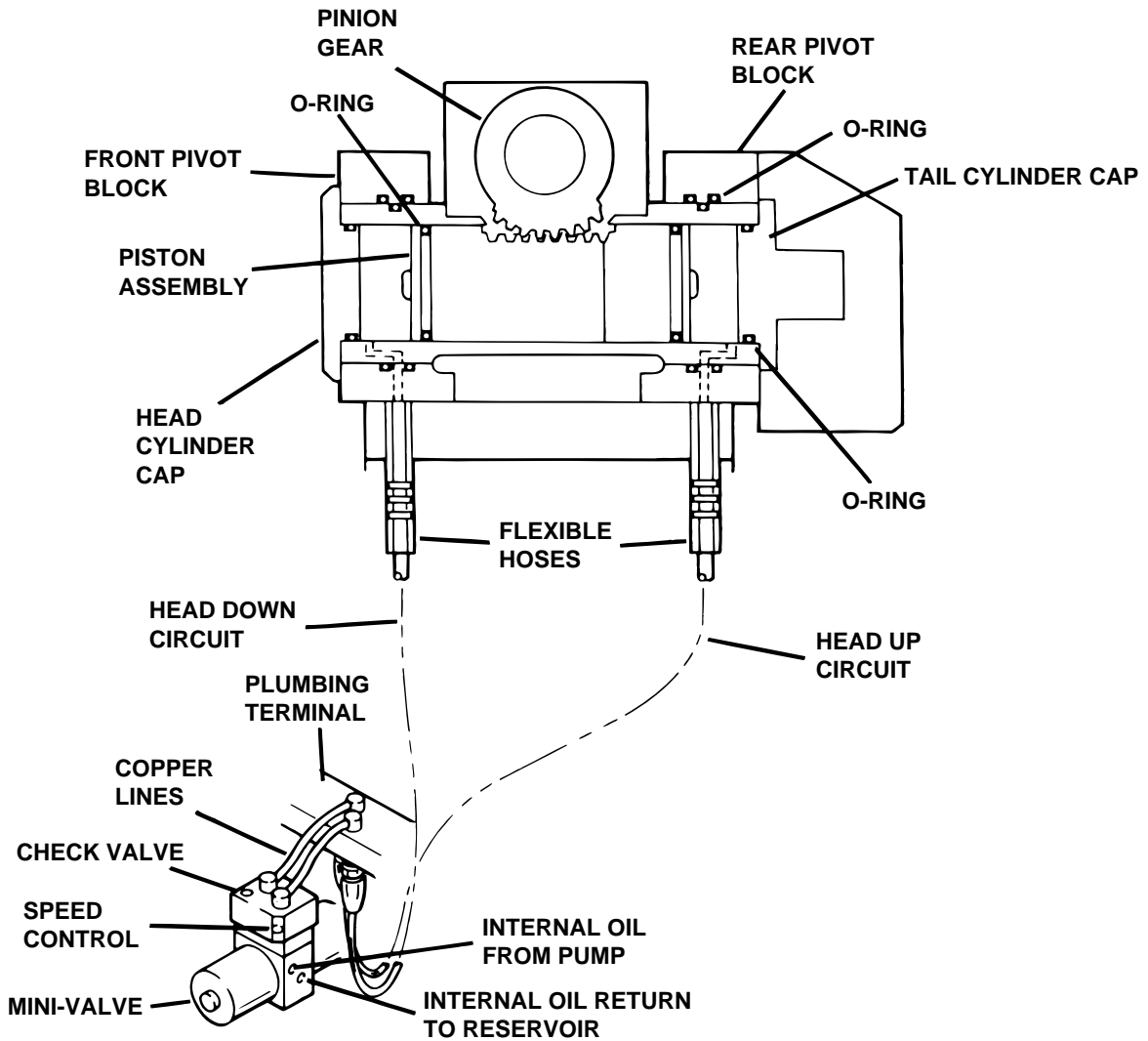

Figure 3-2. Trendelenburg Circuit

### 3-5. LATERAL TILT DIAGNOSIS CHART

Problem	Reason
Lateral tilt function moves improperly	Incorrect Speed Adjustment Spool Valve Not Centered Bad Check Valves Low on Oil Pinched Hose Defective Mini-Valve Pressure Relief Valve Not Set Properly Bad Solenoid Defective Relay Box or Pendant Control
Lateral tilt function chatters or loses position	Defective or Dirty Check Valves Oil Leakage in Circuit Air Inside Cylinder Pinched Hose Low on Oil

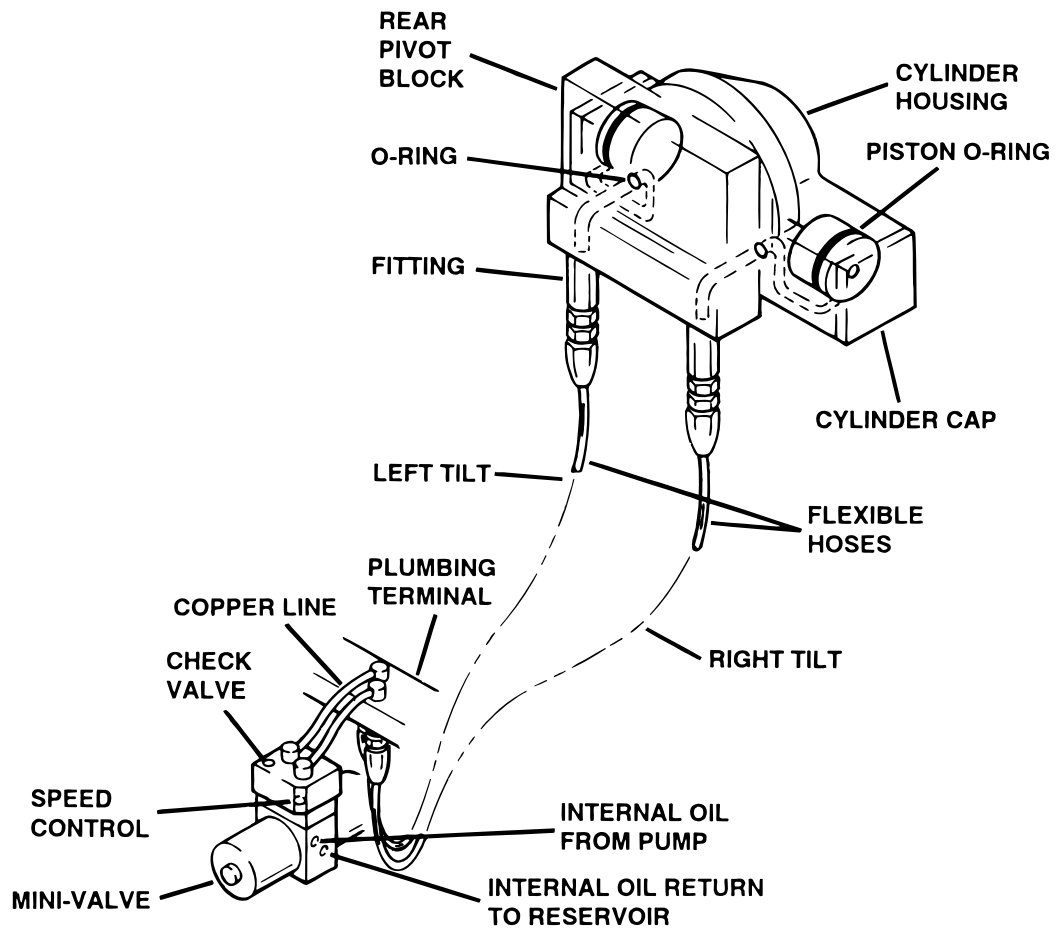

Figure 3-3. Lateral Tilt Circuit

### 3-6. FLEX SYSTEM DIAGNOSIS CHART

**Problem**  
Back Section or Trendelenburg function moves improperly

**Reason**  
Incorrect Speed Adjustment (Trendelenburg, Back section or Flex - check with gauge)  
Spool Valve Not Centered  
Bad Check Valves  
Low on Oil  
Pinched Hose  
Defective Mini-Valve  
Pressure Relief Valve Not Set Properly  
Bad Solenoid  
Defective Relay Box or Pendant Control

**NOTE**

If Flex System does not function properly, check the back section and trendelenburg functions before adjusting the flex system.

Back Section or Trendelenburg function chatters or loses position

Defective or Dirty Check Valves  
Oil Leakage in Circuit  
Air Inside Cylinder  
Pinched Hose  
Low on Oil

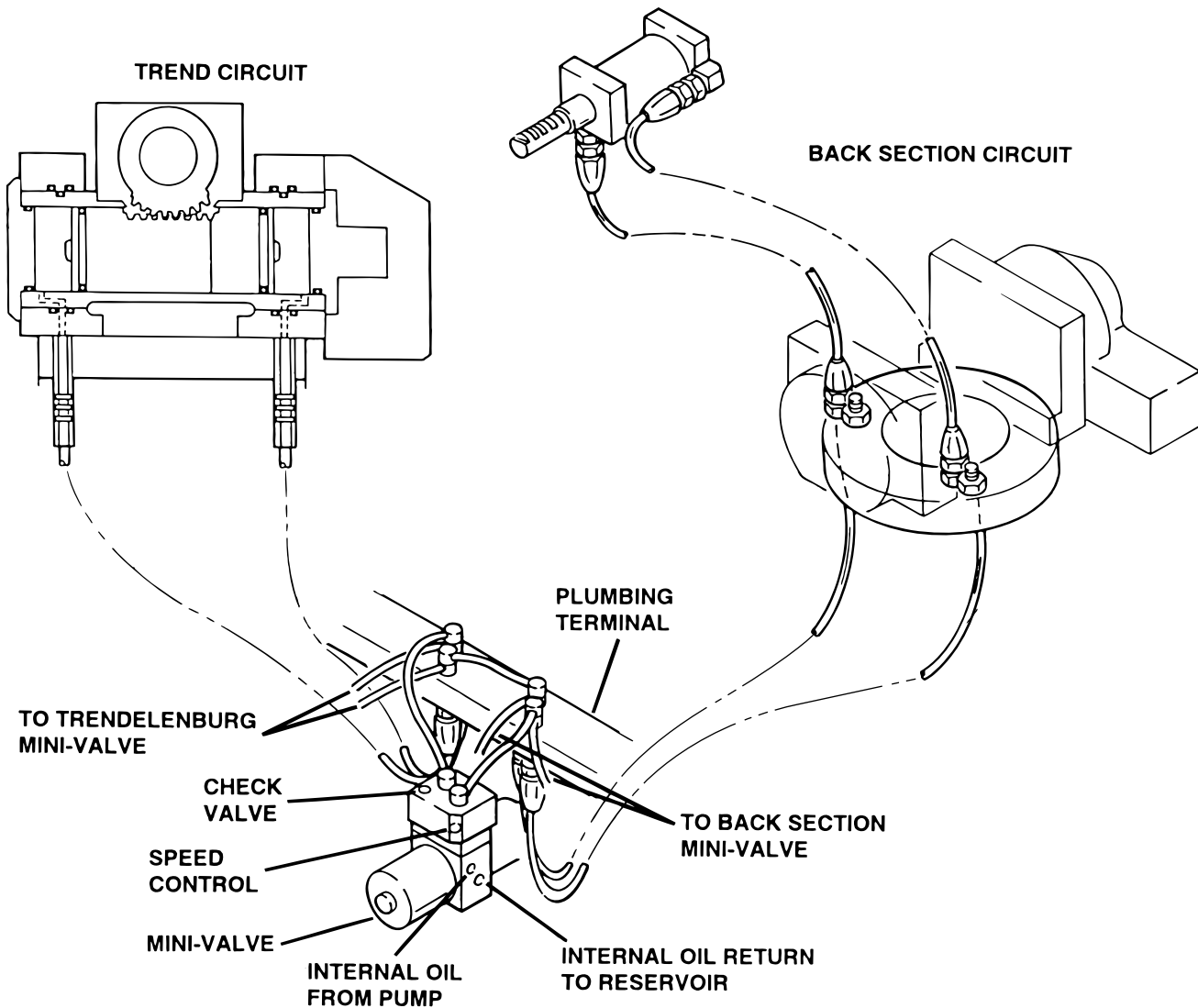

Figure 3-4. Flex System Circuit

### 3-7. BACK SECTION DIAGNOSIS CHART

Problem	Reason
Back Section function moves improperly	Incorrect Speed Adjustment Spool Valve Not Centered Bad Check Valves Low on Oil Pinched Hose Defective Mini-Valve Pressure Relief Valve Not Set Properly Bad Solenoid Defective Relay Box or Pendant Control
Back Section function chatters or loses position	Defective or Dirty Check Valves Oil Leakage in Circuit Air Inside Cylinder Pinched Hose Low on Oil

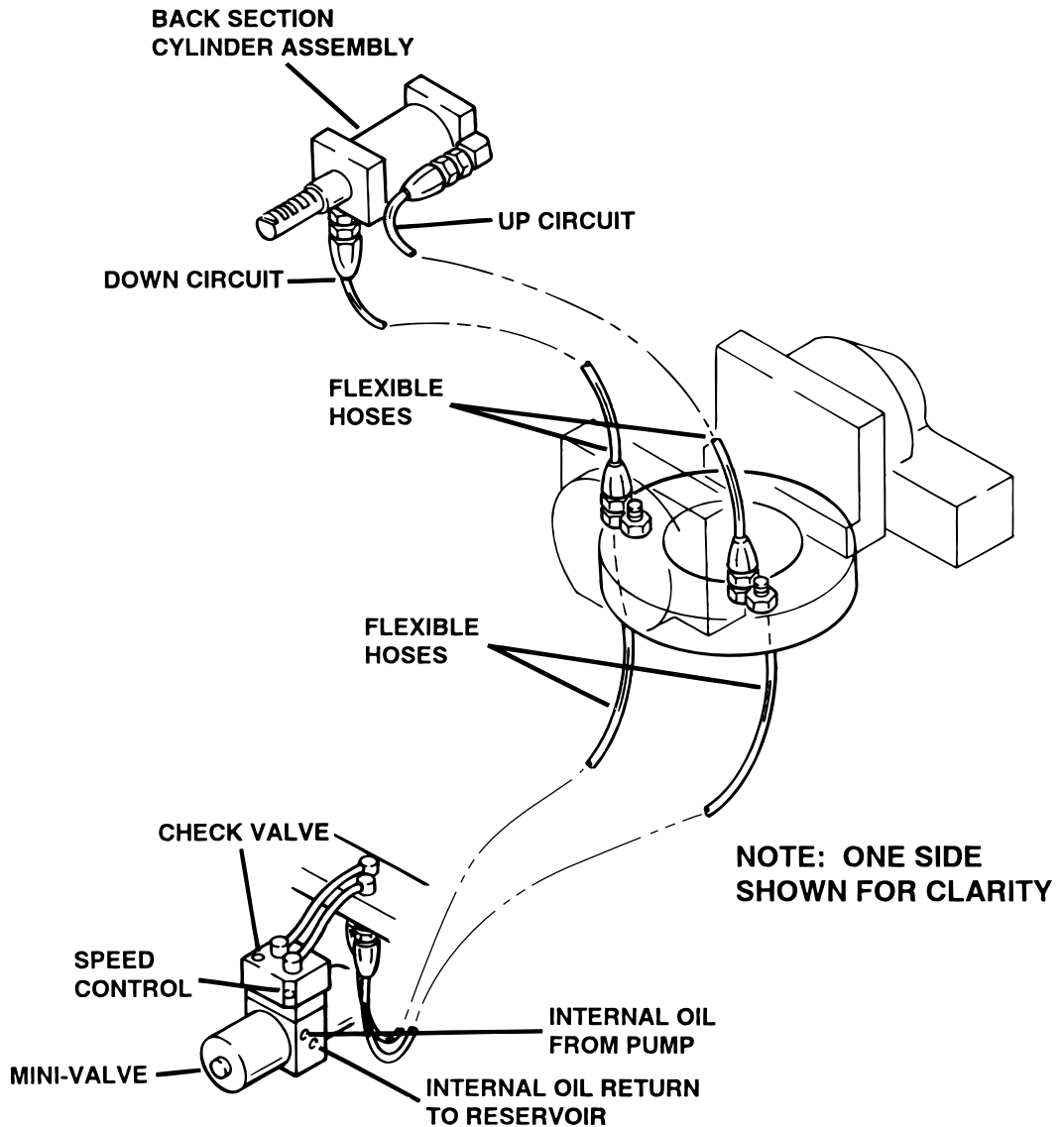

Figure 3-5. Back Section Circuit

### 3-8. LEG SECTION DIAGNOSIS CHART

Problem	Reason
Leg function moves improperly	Incorrect Speed Adjustment Spool Valve Not Centered Bad Check Valves Low on Oil Pinched Hose Defective Mini-Valve Pressure Relief Valve Not Set Properly Bad Solenoid Defective Relay Box or Pendant Control
Leg function chatters or loses position	Defective or Dirty Check Valves Oil Leakage in Circuit Air Inside Cylinder Pinched Hose Low on Oil

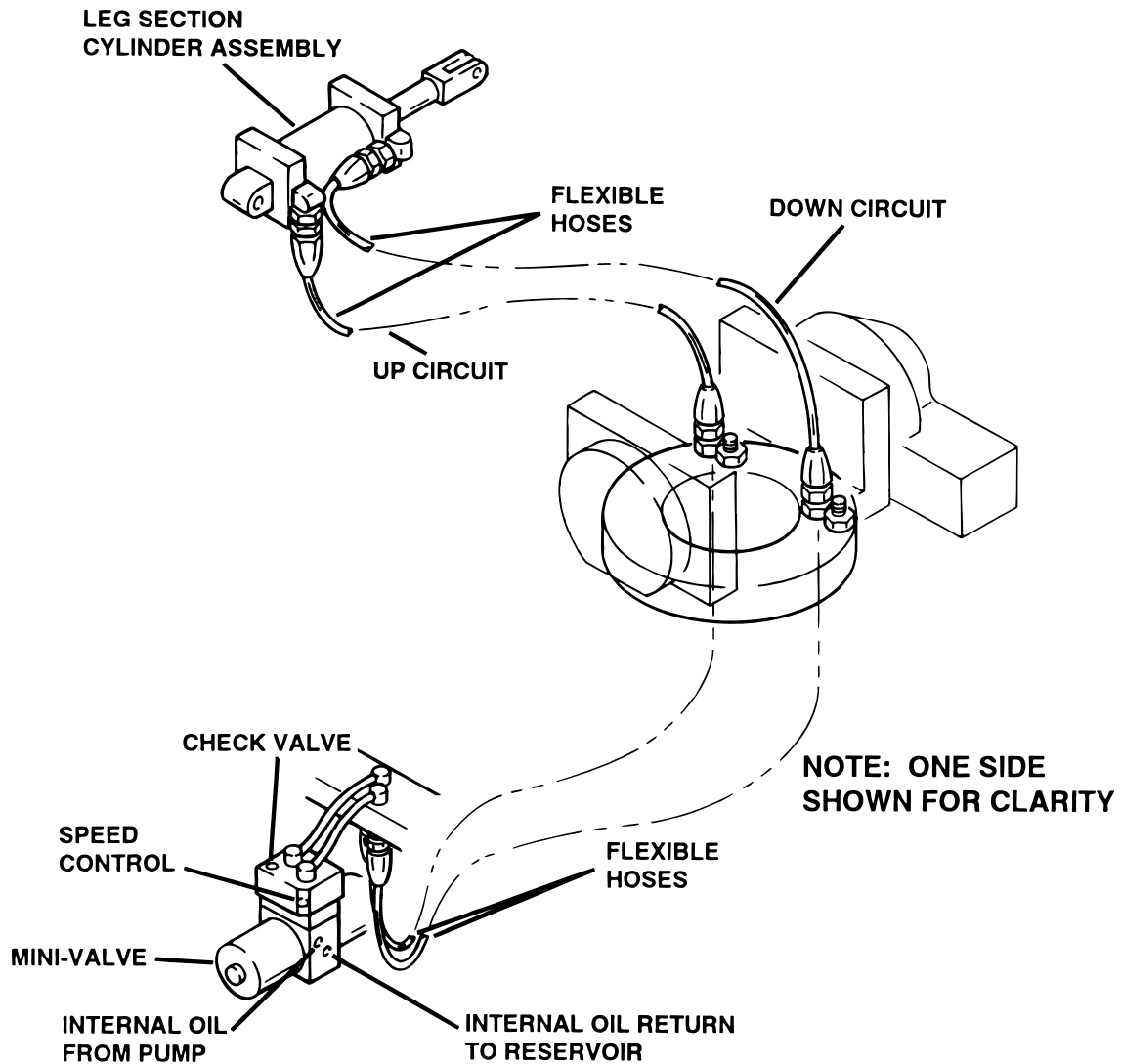

Figure 3-6. Leg Section Circuit

### 3-9. BRAKE CIRCUIT DIAGNOSIS CHART

**Problem**

Brakes will not set properly

**NOTE**

If brakes have been released with the Emergency Brake Release Valve, brakes will not reset until BRAKE UNLOCK Circuit has been activated.

**Reason**

- Emergency Brake Release Valve Open or Defective
- Spool Valve Not Centered
- Bad Check Valve
- Low on Oil
- Pressure Relief Valve Not Set Properly
- Pinched Hose
- Defective Mini-Valve
- Defective Relay Box or Pendant Control

Brakes Will Not Stay Locked

- Emergency Brake Release Valve Open or Defective
- Defective or Dirty Check Valve
- Oil Leakage in Circuit
- Leaking "O" Ring Inside Cylinder

Brakes will not retract properly

- Incorrect Speed Adjustment
- Bad Check Valve
- Spool Valve Not Centered
- Defective Mini-Valve
- Pinched Hose
- Defective Solenoid or Wiring
- Defective Relay Box or Pendant Control

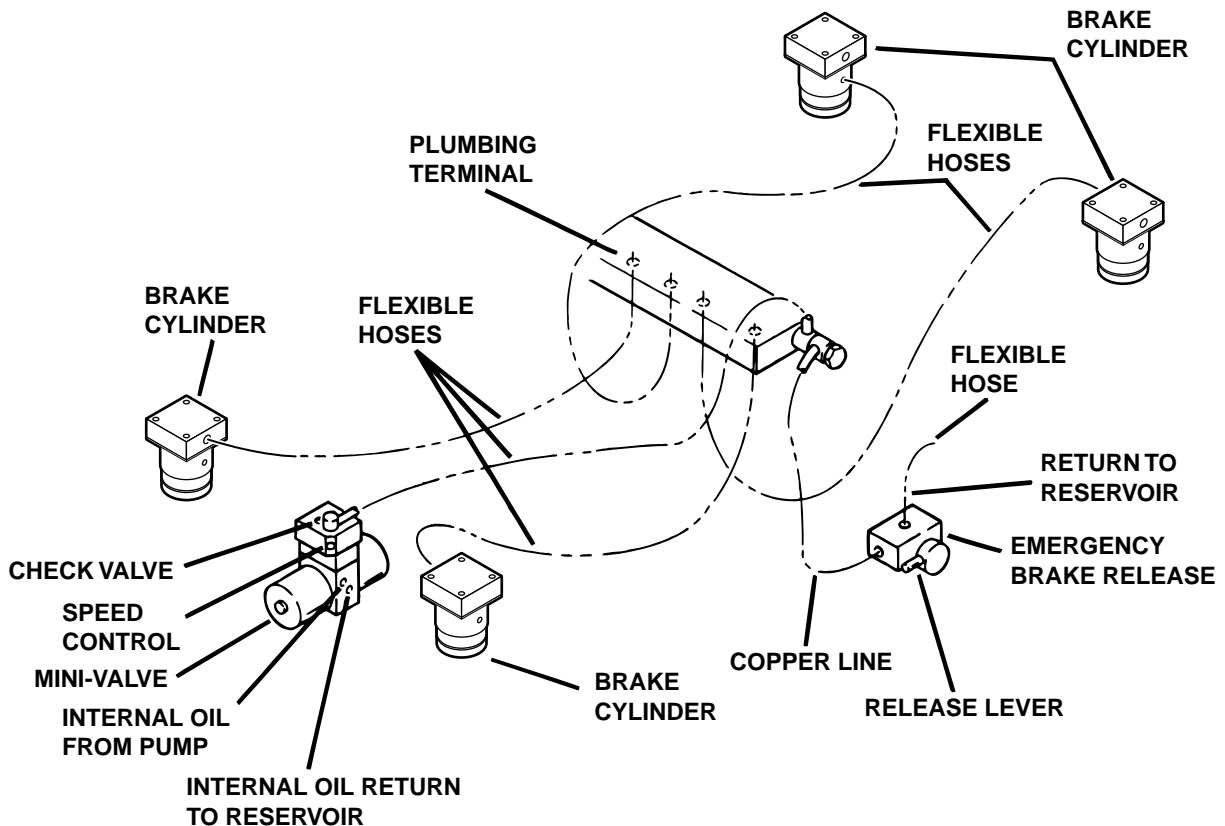
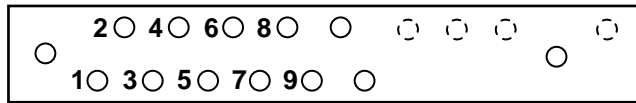

Figure 3-7. Brake System Circuit

### 3-10. Flexible Hose Identification and Placement

The following figures will show the correct placement of the flexible hydraulic hoses used in the table and their respective number codes.

Figure 3-8 shows the hose connections to the plumbing terminal.



<u>NUMBER</u>	<u>FUNCTION</u>
1	ELEVATION
2	REV TREND
3	TREND
4	LAT TILT LEFT
5	LAT TILT RIGHT
6	BACK DOWN
7	BACK UP
8	LEG UP
9	LEG DOWN

**Figure 3-8. Main Plumbing Terminal**

Figure 3-9 shows the placement of the short flexible hoses which connect to the back section cylinders.

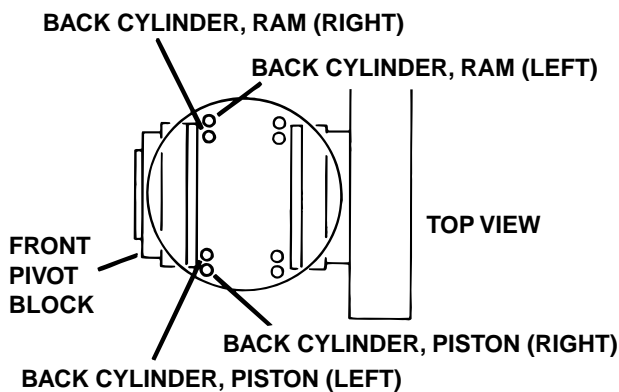

**Figure 3-9. Back Section Hoses**

Figure 3-10 shows the placement of the short flexible hoses which connect to the leg section cylinders.

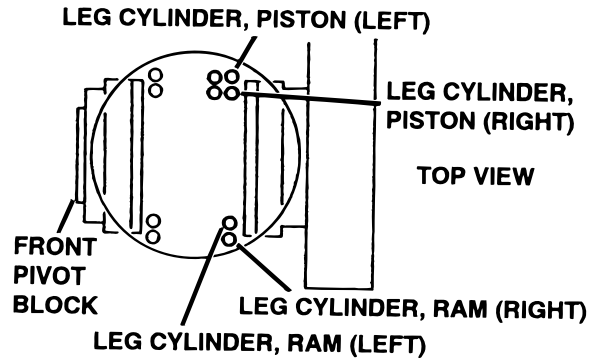
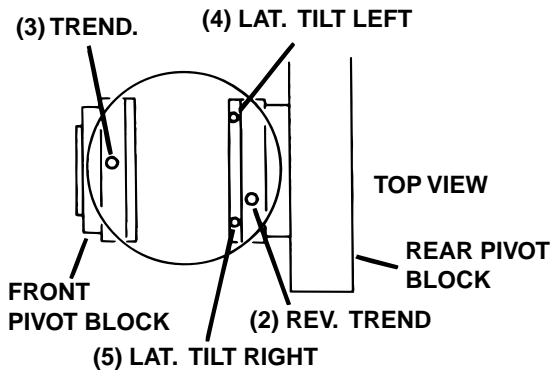

**Figure 3-10. Leg Section Hoses**

Figure 3-11 shows the placement and number code for the long flexible hoses which connect from the plumbing terminal to the front and rear pivot blocks.

**NOTE**

The number codes will be stamped into the elevation clamp ring and the plumbing terminal.



**Figure 3-11. Pivot Block Hoses**

Figure 3-12 shows the placement and number code for the long flexible hoses that connect from the elevation clamp ring to the plumbing terminal.

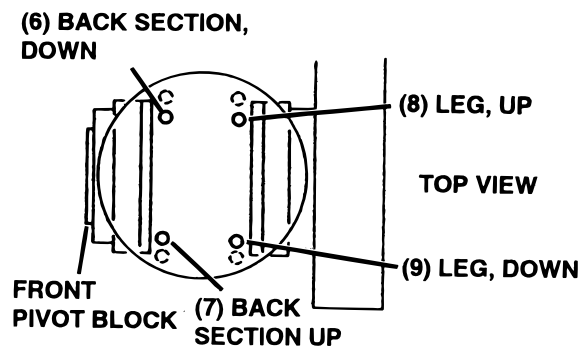

**Figure 3-12. Elevation Clamp Ring Hoses**



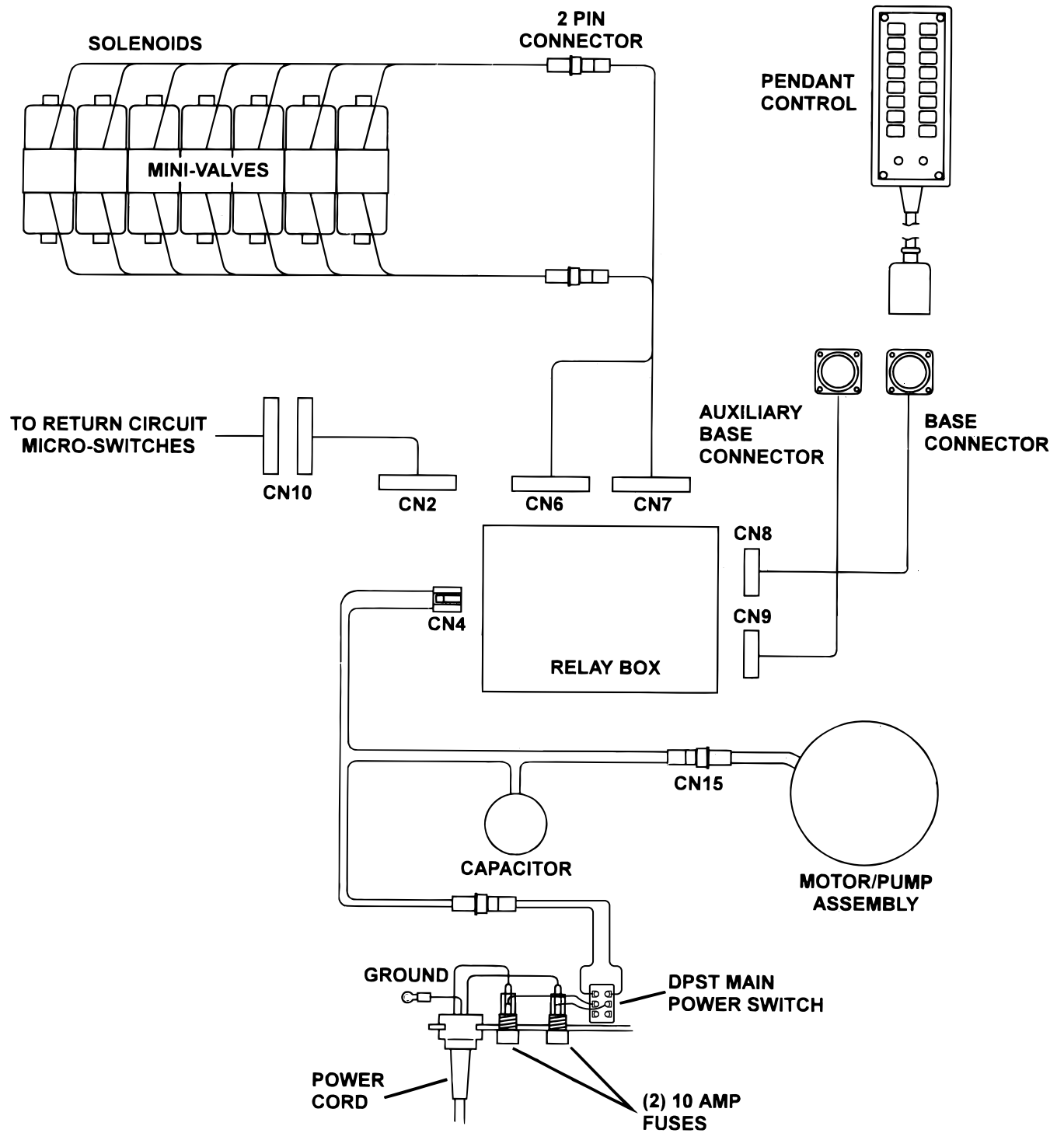

Figure 4-1. 6002 Electrical Circuit Block Diagram

## SECTION IV ELECTRICAL SYSTEM

### 4-1. General

The complete electrical system (with the exception of the hand-held pendant control and the return circuit micro-switches) is contained within the base of the table. The pump motor and the hydraulic valves are controlled electrically with the pendant control.

The electrically operated functions are as follows:

- ELEVATION - Up and Down
- TRENDELENBURG - Head up and down
- LATERAL TILT - Right and left
- BACK SECTION - Up and Down
- LEG SECTION - Up and Down
- FLEX / REFLEX
- RETURN TO LEVEL
- BRAKE UNLOCK - Brake release

The power requirements are 120 VAC, 60 Hz, fuse protected. The main power on-off switch is an enclosed DPST type and the power cord is a three-wire, fifteen foot long, UL listed cord with a three-prong hospital grade plug.

### 4-2. Components

Refer to figure 4-1 for the relationship of the electrical components.

**a.** Wires, Connectors, Switches, Fuse - These provide the path for the various electrical circuits.

**b.** Relay Box - Contains the step down transformer, full wave rectifier, and relay switches. The relay switches are activated by the pendant control and in turn energize the solenoid.

**c.** Hand-Held Pendant Control - Closes micro-switches to activate relay box. Operates on 5 VDC.

**d.** Solenoids - These electrically open and close the hydraulic ports of the mini-valve to direct the fluid to the correct cylinders. They operate on 120 VAC.

**e.** Motor/Pump Assembly - 120 VAC, 60 HZ, 200 Watt capacitor induction motor.

### 4-3. Battery Model Components

The functions of the battery model tables are the same as the standard 120 VAC models. The electrical components and operation however, vary greatly between the two models. To simplify the troubleshooting procedures, the battery model tables are covered separately in Section VI.

## SECTION V ELECTRICAL SYSTEM TROUBLESHOOTING

### 5-1. Troubleshooting Notes

The basic operation of each component will be defined along with a drawing and explanation on how to check it out.

#### NOTE

**This section does not cover the battery table components.** They are covered separately in Section 6.

Certain defective components could cause the entire table to stop functioning or only one control function to stop. It would depend on what part of the component failed. Other defective components would only cause one control function to stop.

The following defective components could cause all control functions to be affected:

- a. Motor/Pump Assembly (starting capacitor)
- b. Main Switch Circuit and Wiring

The following defective components could cause all control functions to be affected or only one control function:

- a. Relay Box
- b. Pendant Control

The component listed below would only affect one control function:

Solenoid

When troubleshooting an electrical circuit, start at the problem and work back to the power source.

### 5-2. Main Switch

The main power supply, 120 VAC, 60 HZ, comes in through the power cord and through the main switch. The main switch opens both lines when in the "OFF" position. An 8 amp or two 10 amp fuses are used to protect the complete electrical system and are located next to the main switch.

#### a. Main Switch Test

The following test will determine if line voltage is applied to connector CN4, which in turn would power the table.

1. Plug the power cord into the 120VAC power supply (wall receptacle) and turn ON the main switch.

2. Disconnect connector CN4 from the relay box. See figure 5-1. Leave all other connectors connected.

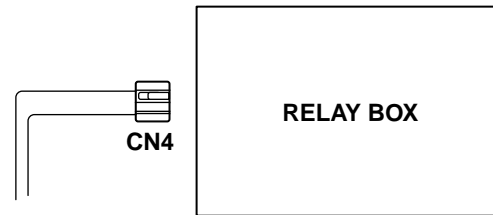

**Figure 5-1. Main Power Test**



**WARNING**



Line voltage (120 VAC) will be measured in this test. Do not touch uninsulated connector pins or meter test leads.

3. Use an AC voltmeter capable of measuring 120 VAC and measure the voltage between pins 1 and 2 (black and white wires) located in connector CN4. See figure 5-2. You should receive line voltage 120 VAC.

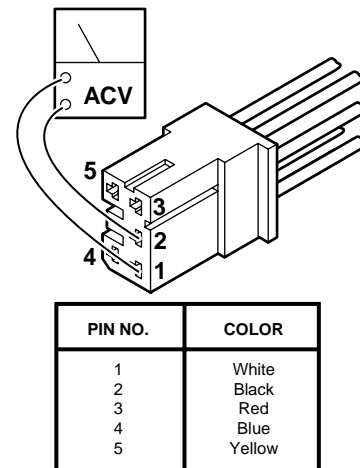

**Figure 5-2. Connector CN4**

## b. Test Results

If you do not receive the correct voltage measurement, the problem would have to be in the wires, main switch, fuses, or power cord. If the correct voltage is obtained, everything is good up to this point and the problem would have to be in another area.

### 5-3. Pendant Control

The Pendant Control consists of 14 micro-switches (buttons). When any of the circuits are completed (by depressing a control button) the appropriate relay contacts (located in the relay box) close applying 120V potential to the appropriate solenoid to operate the mini-valve and the pump/motor. The Pendant Control has only 5-6 volts applied to it.

#### a. Pendant Control Test

The following test will determine if the micro-switches inside the Pendant Control are functioning correctly.

1. Unplug the pendant control from the base of the table. You will be checking the cord side connector.

2. Use an ohmmeter R x 1 scale and check the continuity between pin 1 and pins 4 through 19. See figure 5-3.

3. Ohmmeter must show continuity between the pins that are indicated when the appropriate buttons are pressed.

#### NOTE

Pins 2 and 3 are connected to the LED (power on light on the pendant control) and cannot be checked with an ohmmeter. Pins 17 & 18 are not used.

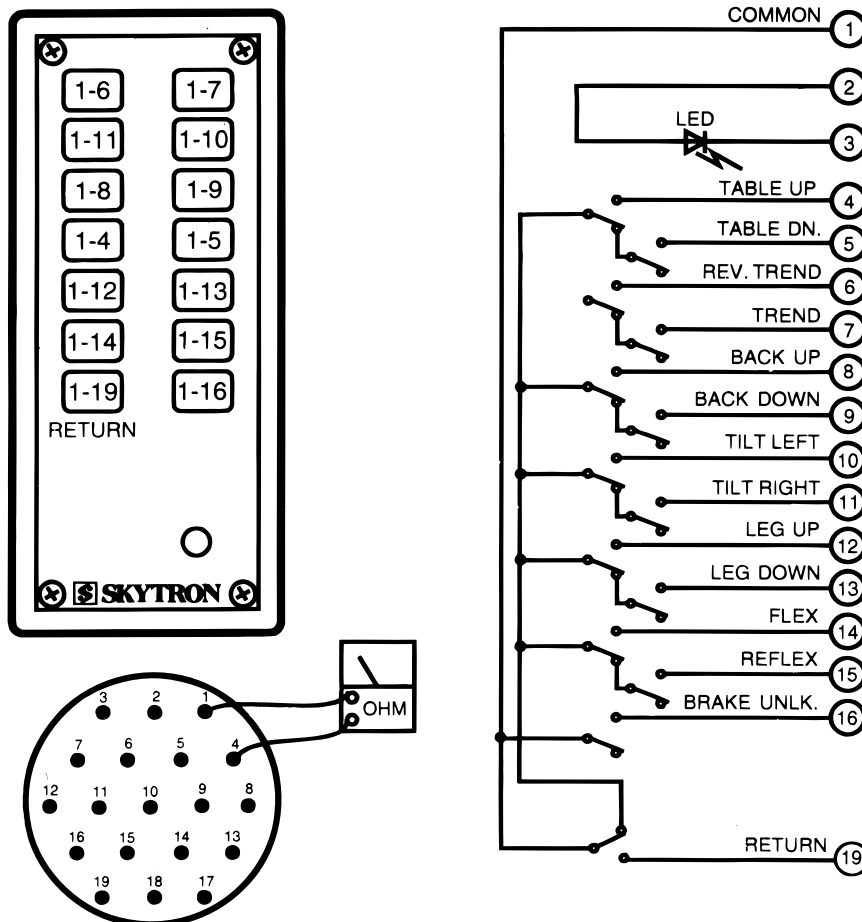

Figure 5-3. Pendant Control Test

**b. Test Results:**

If you do not receive continuity between any of the pins, either the micro-switch in the Pendant Control is defective or a wire is broken. Either of these problems can be repaired easily.

If you receive correct readings with the meter, the Pendant Control is okay.

**c. Wiring Harness Test**

The following test checks the wires leading from the relay box connector CN8 to the 19 pin connector table socket. These wires apply low voltage to the pendant control buttons.

1. The power cord should be plugged into the wall socket and the main switch turned ON.
2. Disconnect the pendant control from the base connector. All other connectors should be connected.
3. Use a DC voltmeter 10V scale and measure the following pins located in the 19 pin table base connector. See figure 5-4.

**NOTE**

Pin 19 will have no voltage potential unless one of the return-to-level micro-switches are activated, i.e. trend or tilt . Pins 17 & 18 are not used.

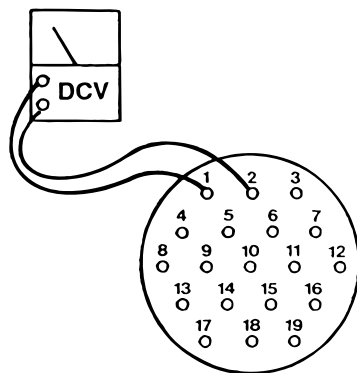

+ TEST LEAD	-TEST LEAD	DC VOLTS
1	2	0
1	3 ~ 16, 19	5 - 6

**Figure 5-4. Table Base Connector**

**d. Test Results:**

If you do not receive the correct voltage reading, the wiring or connector pins may be faulty. Disconnect connector CN8 from the relay box and using an ohmmeter, test the continuity between the corresponding pins in connectors CN8 and the table base connector. See figure 5-5. If the correct readings are obtained, this part of the circuit is okay.

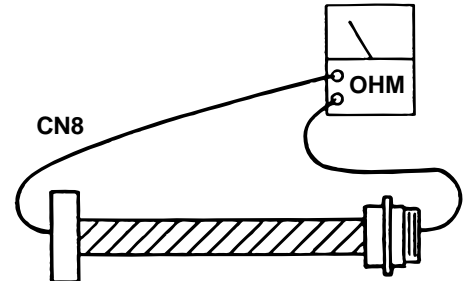

PIN NO.	COLOR	PIN NO.	COLOR
1	Red/White	11	White/Orange
2	White	12	Gray
3	Black	13	White/Gray
4	Red	14	White/Yellow
5	White/Red	15	Purple/White
6	Yellow	16	Black/White
7	Brown	17	Purple
8	White/Brown	18	White/Purple
9	Blue/White	19	Blue/Yellow
10	Orange		

**Figure 5-5. Base Connector Continuity Test**

**5-4. Relay Box**

The 120 volt power supply is directly connected to the relay contacts. When these contacts are closed, 120 volts is supplied to the solenoids which are mounted on the hydraulic mini-valves. One relay is used to supply 120V to the pump/motor and is always activated no matter what control function is selected. The brake locking circuit relay is also activated when any control function other than BRAKE UNLOCK is *initially* selected.

Also, inside the relay box is a step-down transformer and full-wave rectifier which decreases the line voltage to 5.5 volts. This low voltage potential controls the relays by the use of the hand-held pendant control buttons. Basically the relays enable a 5.5 volt potential to control the 120 volt circuit.

The following tests will determine if the relay box is functioning correctly.

**a. Relay Box Input Connector CN4**

1. Plug the power cord into the 120 VAC power supply (wall receptacle) and turn the main switch ON. Leave all connectors connected.



### WARNING



Line voltage (120 VAC) will be measured in this test. Do not touch uninsulated connector pins or meter test leads.

2. Use an AC voltmeter capable of measuring 120 volts and measure the voltage between pins 1 (white) and 2 (black) of connector CN4 for input voltage. See figure 5-6. Meter should read line voltage 120 VAC.

3. Activate any table function with the Pendant Control and using an AC voltmeter, test the voltage at pins 3 and 4 of CN4 for output to the pump. Meter should read 120 VAC.

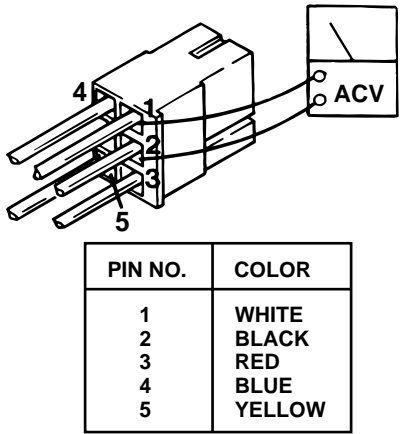

Figure 5-6. Connector CN4

### b. Test Results:

If you do not receive the correct meter readings, the relay box or wiring is defective. If the correct readings are obtained, this part of the relay box is okay. Proceed to the next step.

### c. Relay Box Output Connector CN8

This test checks the low voltage applied to the pendant control buttons.

1. The power cord should be plugged into the wall receptacle and main switch turned ON.

2. Disconnect Pendant Control connector. All other connectors should be connected.

3. Using a DC voltmeter, measure the voltage between pin 1(+) and pins 4 through 19(-) of the table base connector. See figure 5-4. Meter should read 5-6 volts.

### d. Test Results:

If you do not receive the correct meter readings, the relay box or wiring is defective. If the correct readings are obtained, this part of the relay box is okay. Proceed to the next step.

### e. Relay Box Output Connectors CN6 & CN7

This test checks the high voltage (120V) that is used to energize the solenoids.



### WARNING



120 VAC will be measured in this test. Do not touch uninsulated connector pins or meter test leads.

1. The power cord should be plugged into the wall receptacle and main switch turned ON.

2. Disconnect the motor connector CN15. All other connectors should be connected. Test connectors CN6 and CN7 from the back while attached to the relay box.

3. Activate each of the Pendant Control buttons and using an AC voltmeter capable of measuring 120VAC, measure the voltage between the appropriate connector pins located in connector CN6 or CN7. See figure 5-7. Polarity of meter test leads is not important. Meter should read 120VAC.

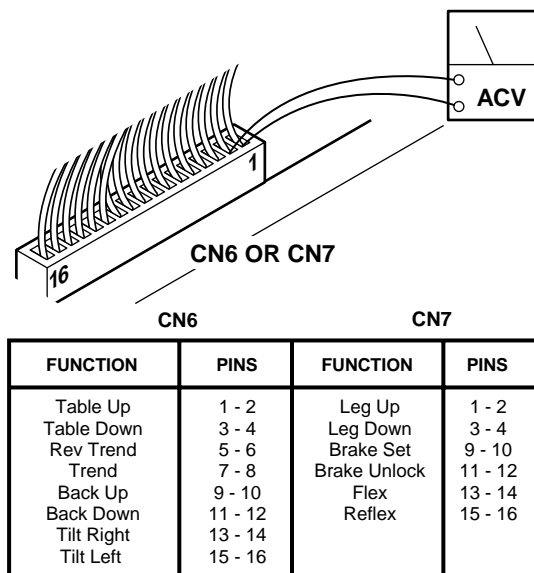

Figure 5-7. Relay Box Output Connectors CN6 and CN7

## f. Test Results:

If you do not receive the correct meter readings, the relay box or wiring is defective and should be replaced.

### NOTE

Before deciding the relay box is defective, check the wires and pins in the connector blocks to make sure they are not loose or making a bad connection with their mate.

## 5-5. Solenoids

The solenoids are energized by 120 volt potential that is controlled by the relays located inside the relay box.

The solenoid windings are protected from excessive heat with an internal thermal fuse that will open after approximately seven (7) minutes of continuous operation. The solenoid must be replaced if the internal thermal fuse has been blown. The solenoids are mounted directly on either side of the hydraulic mini-valves and push the spool valve in one direction or the other depending upon which solenoid is activated.

### a. Solenoid Test

The following tests check the voltage applied to the solenoids and the resistance of the solenoid coil.

### NOTE

If a solenoid does not function when the pendant control button is pushed, the problem could be the pendant control, the relay box, or the solenoid.

### NOTE

Each solenoid is controlled with 120V source coming from the relay box. This source can easily be checked by measuring the voltage at the 2 pin connector in question.



**WARNING**



Line voltage will be measured in this test. Do not touch uninsulated connector pins or meter test leads.

### b. Step #1

1. Plug the table cord into the wall receptacle and turn main switch ON.
2. Disconnect the 2 pin connector from the solenoid in question. See figure 5-8.
3. Use a voltmeter capable of measuring 120 VAC and measure the voltage across the 2 pin connector. Polarity of meter leads is not important.

### NOTE

The appropriate pendant control button must be pushed during this test. The motor will run when this test is performed, and the brake locking solenoid will be activated by any function other than UNLOCK.

### c. Test Results:

If you do not receive the correct voltage, the problem could be in the wires leading to connectors CN6 and CN7. The problem could also be in the relay box or the Pendant Control (refer to appropriate section for troubleshooting).

If the correct voltage is obtained, everything is good up to that point and the problem is more than likely the solenoid.

### d. Step #2

The solenoid can be checked out using an ohmmeter R x 1 scale.

1. Measure the resistance between the two pins of the connector in question. See figure 5-8. Connector being tested must be disconnected. Polarity of meter leads is not important.
2. The meter should read approximately 80-90 ohms at room temperature.

3. Measure the resistance between either pin and ground.
4. Meter should read infinity.

**e. Test Results:**

If the solenoid does not check out with the meter, it is more than likely defective and must be replaced.

**NOTE**

Whenever there are several components of the same type, a defective unit can also be detected by substituting a known good unit or wire connector. In some cases this may be faster than using a multi-meter.

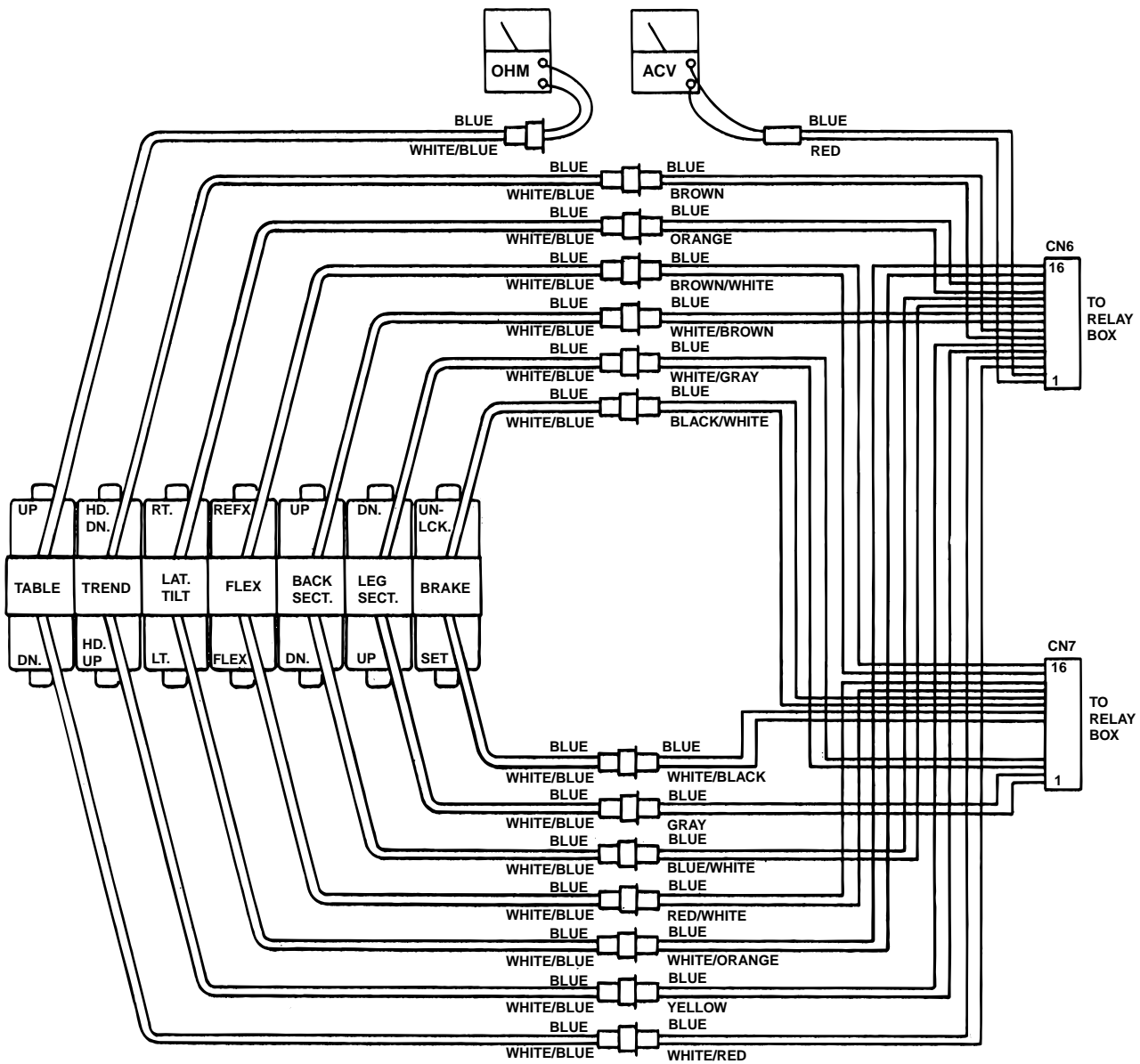

**Figure 5-8. Solenoid Test**



## 5-6. Motor/Pump Assembly

The electric motor is a capacitor start type with a rating of 120 VAC, 200 watts. The field windings are protected with a thermal protector that will open the winding circuit if the motor is run continuously for approximately 10 minutes. This protector will take about 10 minutes to automatically reset. The oil pump unit is attached to the bottom of the motor and is a gear type displacement pump with a pumping capacity of .4 liter per min. The Motor/Pump Assembly is mounted on an insulated motor plate in the base of the table. The starting capacitor is mounted along side the motor/pump assembly

### a. Motor/Pump Test

The following tests will check the voltage applied to the motor and the resistance of the motor field windings.



**WARNING**

Line voltage will be measured in this test. Do not touch uninsulated connector pins or meter test leads.

### b. Step #1

1. Plug the power cord into 120 VAC power supply (wall receptacle). Turn main switch ON.

2. Disconnect the 3 pin connector CN15 at the motor. Leave all other connectors connected. See figure 5-9.

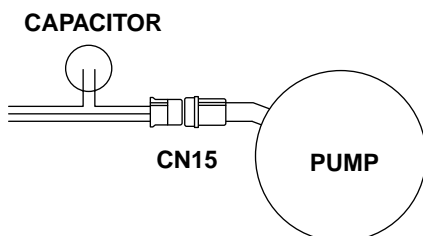

**Figure 5-9.**

3. Use a voltmeter capable of measuring 120 VAC and measure the following connector pins in connector CN15. See figure 5-10.

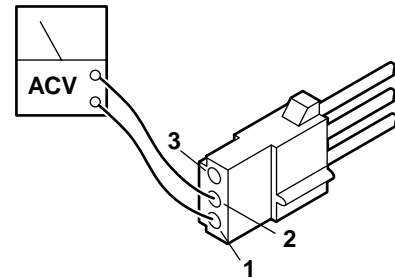

PIN NO	AC VOLTS
1 - 2	120
1 - 3	120
2 - 3	0

**Figure 5-10. Connector CN15**

### c. Test Results:

If you do not receive the correct meter readings, the problem could be in the wires, connectors, relay box, or main switch (refer to appropriate section for troubleshooting).

If the correct voltage is obtained, everything is good up to that point and the problem could be either the motor or the starting capacitor.

### d. Step #2

If the starting capacitor is shorted or grounded, the motor will not run. Capacitors very seldom fail, and it requires a dielectric tester to accurately test one. However, an ohmmeter can be used to determine if the capacitor will store a low voltage charge and most of the time this is adequate.

1. Turn the main switch OFF.
2. Connector CN15 should be disconnected.

3. Use the R x 100 scale of the ohmmeter and touch pins 2 and 3 of connector CN15. See figure 5-10.

**e. Test Results:**

The meter needle should move up scale and then back down to infinity. This would indicate that the capacitor is storing an electrical charge.

**NOTE**

The capacitor may have to be discharged first (by shorting pins 2 and 3 together) before you will be able to see the ohmmeter needle swing up the scale.

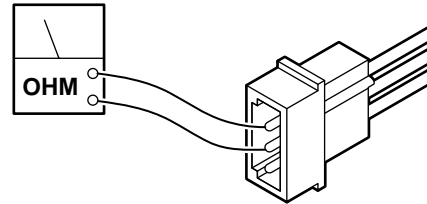

**f. Step #3**

The motor windings can be statically checked for resistance using an ohmmeter.

1. Turn main power switch OFF.
2. Connector CN15 should be disconnected.
3. Use the R x 1 scale of the ohmmeter and measure the resistance between the pins located in the pump connector CN15. See figure 5-11.

PIN NO	METER
1 - 2	Approx. 5 ohms
1 - 3	Approx. 4 ohms
2 - 3	Approx. 8 ohms

**Figure 5-11. Pump Connector CN15**

**g. Test Results:**

If you do not receive the correct meter readings, the motor or wiring is defective.

### 5-7. Return-to-Level Micro-Switches.

The return-to-level feature is activated by a single button on the pendant control and automatically levels the major table functions, lateral tilt, trendelenburg, back section, and leg section.

The return-to-level system consists of 6 micro-switches, 2 electrical connectors, and the related wiring. The micro-switches are mounted on or adjacent to the function they control and are wired for normally open or normally closed operation. The micro-switches are lever actuated and can be adjusted at the individual switch mounting brackets. See figure 5-12.

The micro-switches operate on low voltage, and control the function circuits (pump/motor and appropriate solenoid valves) when activated by the pendant control RETURN button.

The micro-switches are wired to the relay box through a riser cord and to the 15 pin connector CN2. See figure 5-12 for switch location and identification.

### 5-8. Troubleshooting

If a problem is suspected in the return circuits, disconnect the connector CN2 from the Relay Box to eliminate the circuits. Ensure that all table functions operate properly using the Pendant Control. If the functions do not work properly using the Pendant Control, refer to the appropriate test section and make all needed repairs before working on the return circuits.

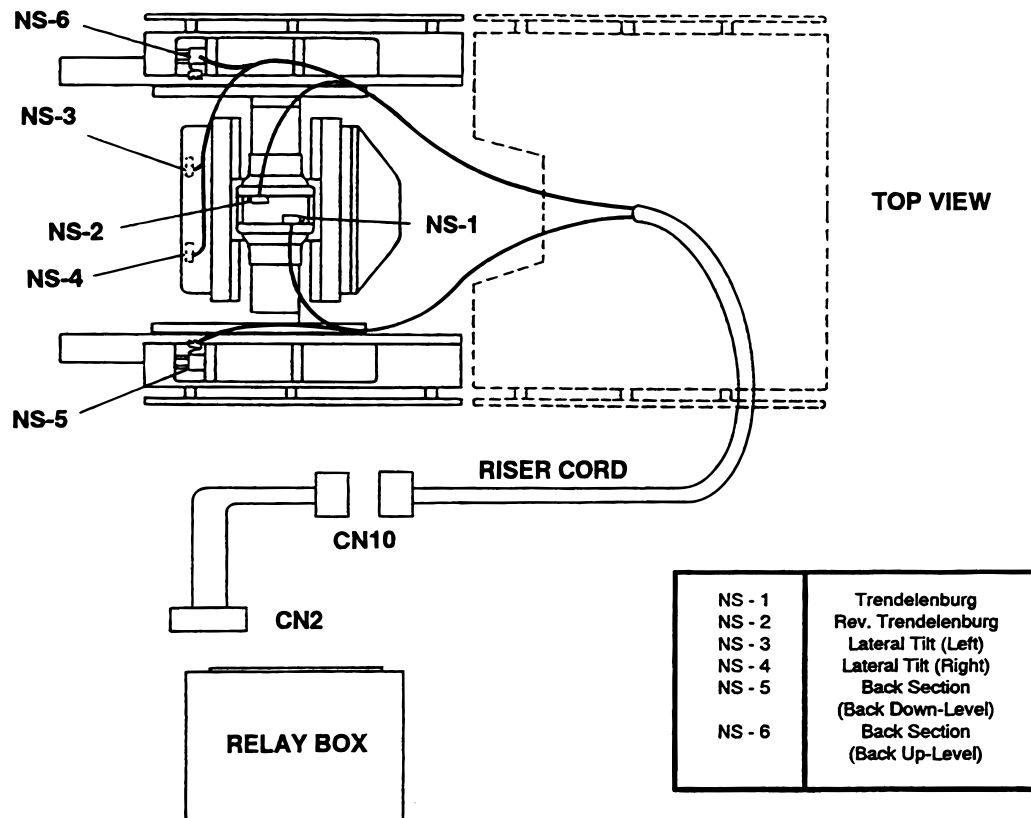

Figure 5-12.

**NOTE**

It is normal for the back section to move up if the RETURN button is pushed when connector CN2 is disconnected from the relay box.

operation at the appropriate pin numbers for the micro-switch in question as shown in figures 5-14 through 5-18.

**NOTE**

Be sure to isolate the circuit when making continuity checks.

All of the micro-switches are connected to the relay box via a wiring harness and the micro-switch riser cord using connectors CN2 and CN10. Connector CN10 is located under the slider shroud in the same area as the hydraulic hoses. Connector CN2 plugs into the relay box and is the most convenient location to make circuit continuity checks. See figure 5-13 for connector pin locations.

**NOTE**

If you do not receive the proper continuity results at connector CN2 it does not necessarily mean the micro-switch is defective. There could be a problem with the riser cord between connectors CN2 and CN10, or in the wiring from the switch to connector CN10. Further tests will have to be made to determine the exact problem.

**a. Switch Test**

Turn Main Power ON, lock the table brakes, and place the table top sections in a level position. Disconnect connector CN2 from the relay box and using an ohmmeter, test the wiring and switch

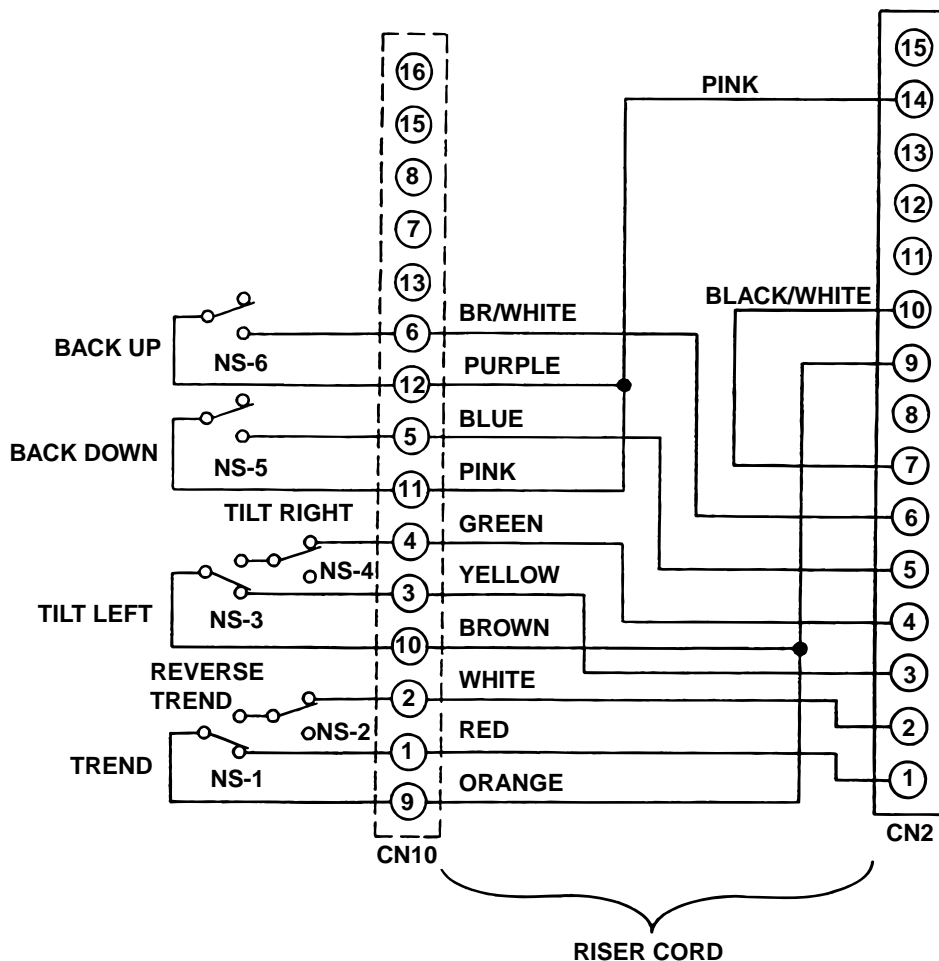
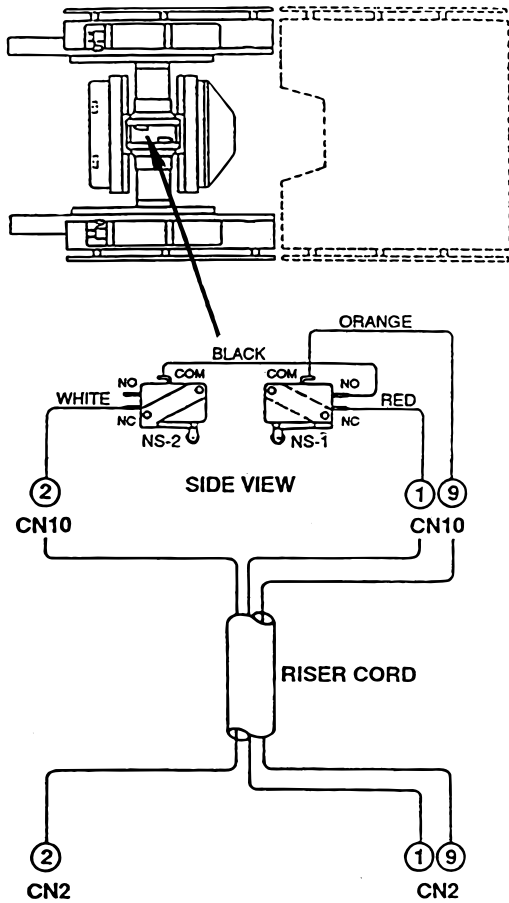

Figure 5-13. Return Micro-Switch Test



**NS-1. Trendelenburg**

Test at pins 1 & 9

Table Position	Switch Position	Meter Reading
Level	Open	Infinity
Head Up	Open	Infinity
Head Dn	Closed	0

When table is in Trendelenburg Position, NS-1 brings the top back to level.

**NS-2. Reverse Trendelenburg**

Test at pins 2 & 9

Table Position	Switch Position	Meter Reading
Level	Open	Infinity
Head Up	Closed	0
Head Dn	Open	Infinity

When table is in Reverse Trendelenburg Position, NS-2 brings the top back to level.

**Figure 5-14. Trendelenburg Return Switches**

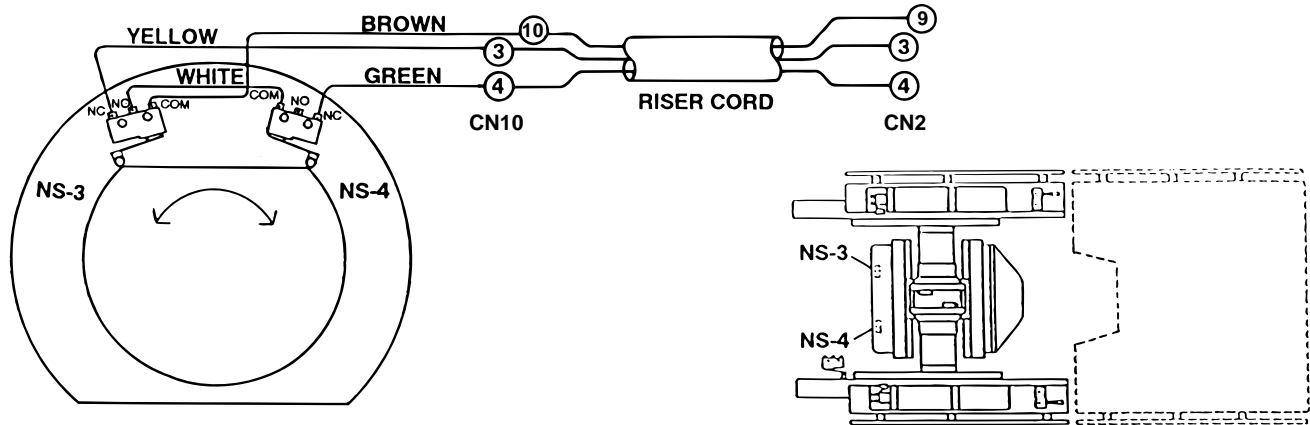

**NS-3. Lateral Tilt-Left**

Test at pins 3 & 9

Table Position	Switch Position	Meter Reading
Level	Open	Infinity
Tilt-Right	Open	Infinity
Tilt -Left	Closed	0

When table is in Tilt-Left Position, NS-3 brings the top back to level.

**NS-4. Lateral Tilt-Right**

Test at pins 4 & 9

Table Position	Switch Position	Meter Reading
Level	Open	Infinity
Tilt-Right	Closed	0
Tilt-Left	Open	Infinity

When table is in Tilt-Right Position, NS-4 brings the top back to level.

**Figure 5-15. Lateral Tilt Return Switches**

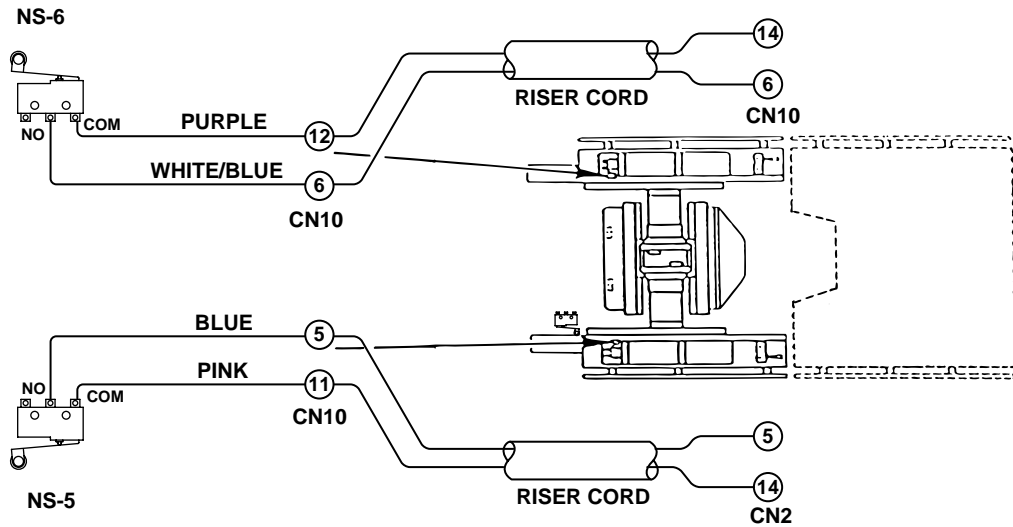

**NS-5. Back Section Down**

Test at pins 5 & 14

Table Position	Switch Position	Meter Reading
Level	Closed	0
Back-Dn	Open	Infinity
Back-Up	Closed	0

When the Back Section is Down, NS-5 brings the Back Section Up to level.

**NS-6. Back Section Up**

Test at pins 6 & 14

Table Position	Switch Position	Meter Reading
Level	Open	Infinity
Back-Dn	Open	Infinity
Back-Up	Closed	0

When the Back Section is Up, NS-6 brings the Back Section Down to level.

**Figure 5-16. Back Section Return Switches**

**b. Switch Adjustment.**

If proper readings are not obtained during test or if table does not properly return to level, use the following procedure to adjust the switches.

1. Apply table brakes and (using a level) level the table top using the TRENDELENBURG and LATERAL-TILT function buttons on the pendant control.

2. For all switches except the Leg Section switches, carefully loosen the switch retaining screws, and adjust the switches as needed. See figure 5-17.

3. To adjust the Leg Section switches remove seat section top, loosen the 2 phillips head screws securing bracket, adjust the switch, tighten the screws and replace the seat section top. See figure 5-18.

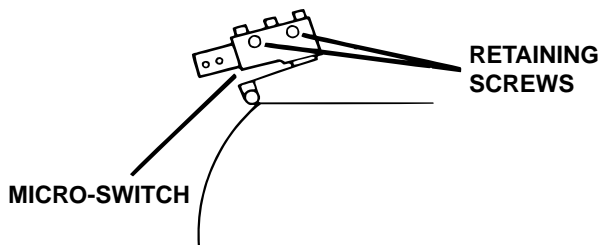

**Figure 5-17. Micro-Switch Adjustment**

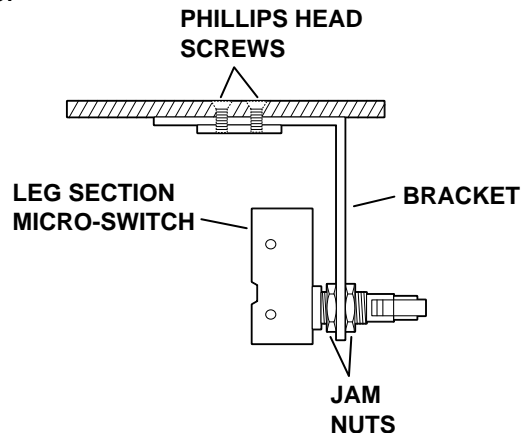

**Figure 5-18. Leg Section Micro-Switch Adjustment**

# 6002B

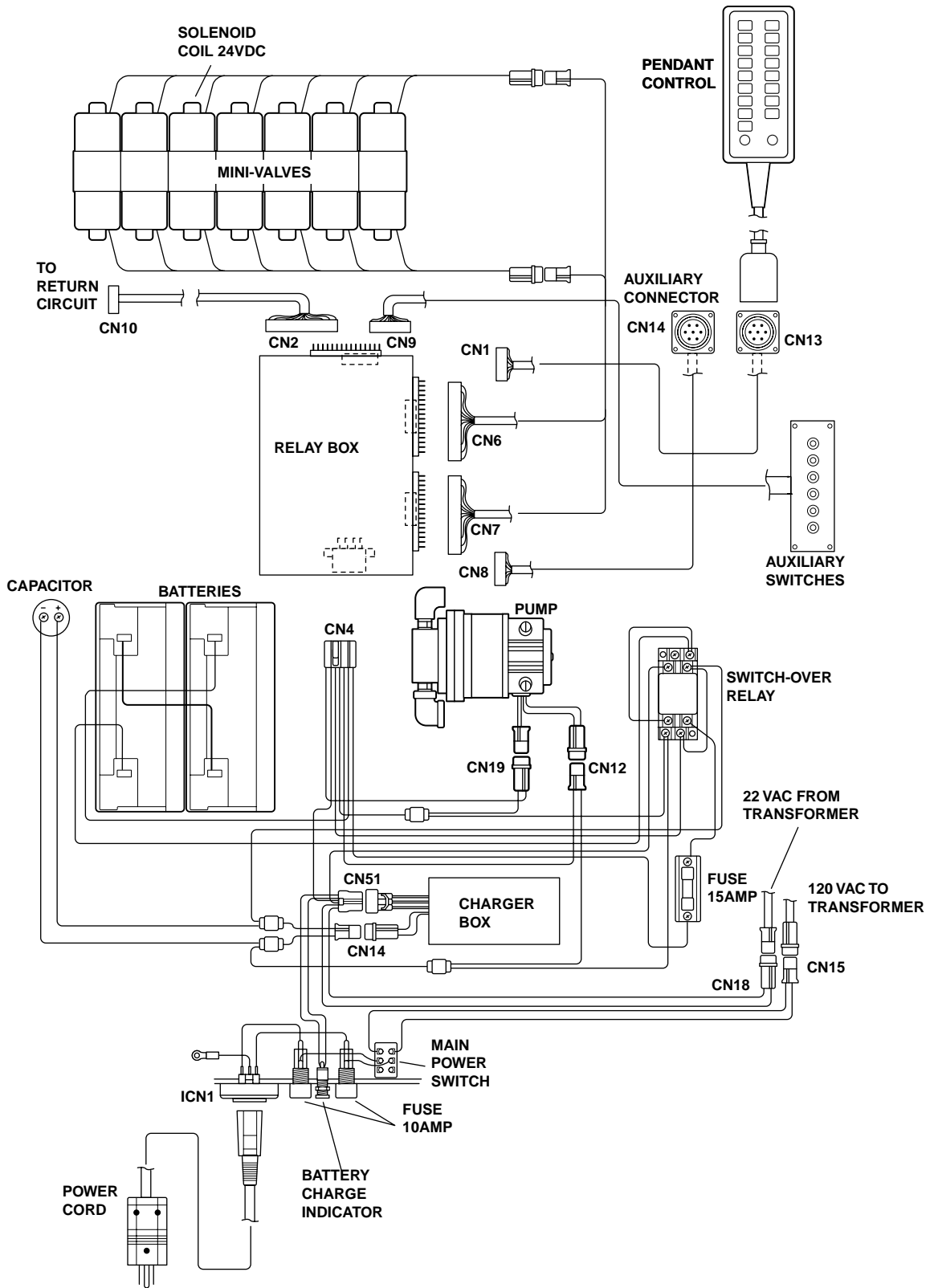

Figure 6-1. Electrical Circuit Block Diagram, Model 6002B

**SECTION VI -6002B- BATTERY MODEL, ELECTRICAL TROUBLESHOOTING****6-1. General**

The battery table components operate on 24VDC. The internal charging system also incorporates the components to transform the 120VAC input to 24VDC output to the components.

**NOTE**

**This section covers the electrical troubleshooting for the 6002B model ONLY.**

**6-2. Troubleshooting Notes**

The basic operation of each component will be defined along with a drawing and explanation on how to check it out.

Certain defective components could cause the entire table to stop functioning or only one control function to stop. It would depend on what part of the component failed. Other defective components would only cause one control function to stop.

The following defective components could cause all control functions to be affected:

- a. Motor/Pump Assembly
- b. Main Switch Circuit and Wiring

The following defective components could cause all control functions to be affected or only one control function:

- a. Relay Box
- b. Pendant Control

The component listed below would only affect one control function:

Solenoid

When troubleshooting an electrical circuit, start at the problem and work back to the power source.

**NOTE**

•On the battery model tables, troubleshooting should begin by switching the operating mode. For example; if a function fails when attempting to operate the table in the AC120V mode, switch to the BATTERY mode. If the function now operates, the problem is probably located between the power cord and the relay box. If the function also fails when in battery operation, use the auxiliary switches to operate the function. If the function now operates, the problem is probably in the pendant control, connectors or wiring from the pendant control to the relay box.

•All connector pins are numbered usually with very small numbers.

**6-3. Main Switch**

The main power supply, 120 VAC, 60 HZ, comes in through the power cord and through the main switch. The main switch opens both lines when in the "OFF" position. Two 10 amp fuses are used to protect the complete electrical system and are located next to the main switch.

**a. Main Switch Test**

The following test will determine if line voltage is applied to connector CN15, which in turn would supply 120VAC power to the table.

1. Plug the power cord into the 120VAC supply (wall receptacle) and turn the main switch ON.
2. Disconnect connector CN15. See figure 6-1. Leave all other connectors connected.

**WARNING**

Line voltage (120 VAC) will be measured in this test. Do not touch uninsulated connector pins or meter test leads.



3. Use an AC voltmeter capable of measuring 120 VAC and measure the voltage between pins 1 and 2 (black and white wires) located in connector CN15. See figure 6-3. You should receive line voltage 120 VAC.

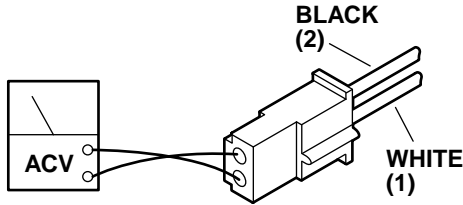

Figure 6-3. Connector CN15 Test

**b. Test Results**

If the correct voltage is obtained, everything is good up to this point and the problem would have to be in another area.

If you do not receive the correct measurements, the problem would have to be in the wires, main switch, fuses, or power cord.

Check the continuity from the power cord connector ICN1, through the fuses, switch and wiring to connector CN15. Remove the power cord, disconnect CN15 (black and white wires), and test as shown in figure 6-4.

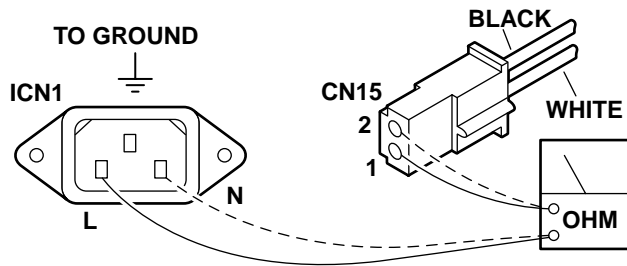

Figure 6-4. CN15 to ICN1 Continuity Test

**6-4. Batteries**

The BATTERY operating mode is powered by two 12 volt batteries connected in series to provide the 24 volt operating power.

The battery system voltage should be 24VDC at a range of 22VDC to 26VDC. If the battery charge level falls below 23.5 volts the BATTERY operation indicator on the pendant control will blink indicating that the batteries require recharging. The built-in

charging system automatically keeps the batteries at the proper charge level when the AC120V operating mode is ON. The charging system will operate while the table is being operated in the AC120V mode.

**a. Battery System Test**

1. Disconnect the main power cord and using a DC voltmeter, test each individual battery at its terminals. Meter should read 12VDC ± 1V.

2. To accurately test the batteries, they must be tested under a full load. Disconnect the main power cord and make sure all other connectors are connected.

3. Turn BATTERY power ON and elevate the table to its full up position.

4. Continue to press the TABLE UP button on the pendant control so that the pump motor continues to run and using a DC voltmeter, check the voltage drop of each battery individually. See figure 6-5.

5. Meter should read 12VDC ± 1VDC.

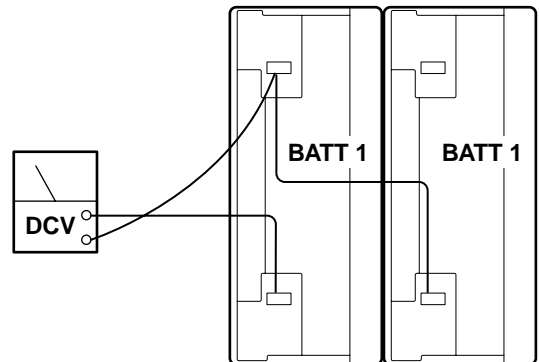

Figure 6-5.

**b. Test Results**

A reading of 11 volts or below indicates the battery needs charging.

After batteries have been fully charged, repeat the full load test. If either battery's voltage drops below 11VDC it should be replaced.

**6-5. Battery Charging Box/AC120V Transformer**

The Battery Charging Box contains the battery charging system as well as the components for AC120V operation (except the transformer).

**a. Transformer Test**

1. Confirm 120VAC input at CN15 using Main Switch test in 6-3a.
2. Connect CN15, disconnect CN18 (brown and red wires) and using an AC voltmeter, test the transformer output at CN18. See figure 6-6.
3. Meter should read 22VAC.

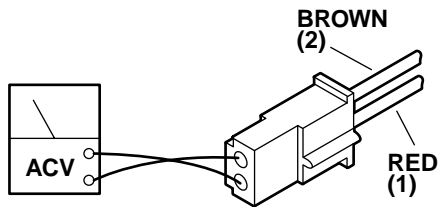

**Figure 6-6. Connector CN18 Test**

**b. Test Results**

If the correct voltage is obtained, everything is good up to this point and the problem would have to be in another area.

If you do not receive the correct measurements, the problem may be in the wires, connectors, or transformer. The transformer is located in the rear of the base under the stainless steel base cover. The stainless steel cover will have to be disconnected and lifted from the base for access to the transformer for further testing.

**c. Battery Charging Box Test**

1. Make sure all connectors are connected and turn AC120V operation ON. Using a DC voltmeter, test pin 3(+) and pin 4(-) of CN51. DO NOT disconnect connector CN51. See figure 6-7.

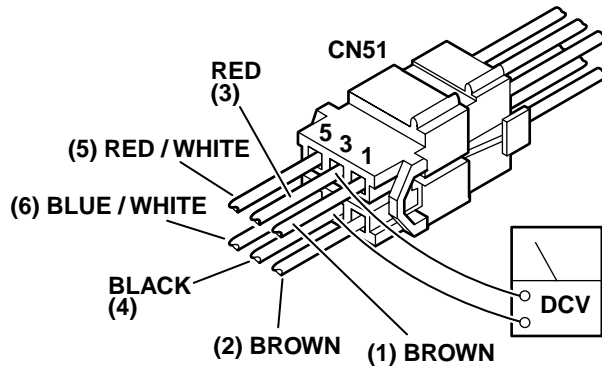

**Figure 6-7. Connector CN51**

2. Meter should read  $26.5 \pm 0.5VDC$ .
3. Test pin 5(+) and pin 6(-) of CN51 with DC voltmeter to test operation of CHARGING indicator light (next to power cord connector).
4. Meter should read  $26.5 \pm 0.5VDC$  if charger is operating. If batteries are fully charged there will be under 5 volts at pins 5 and 6.

**d. Test Results**

If you do not receive the correct readings, the charger system, connectors, wires, or the transformer may be defective.

**e. Charging System Output Adjustment**

If output reading at pins 3 and 4 is not  $26.5 \pm 0.5VDC$ , the output can be adjusted at the variable resistor VR-R59 on the circuit board inside the Charging Box. See figure 6-8. Turn the adjuster clockwise to decrease the voltage. Counterclockwise to increase the voltage.

**NOTE**

The battery connectors must be disconnected to adjust the battery charger output.

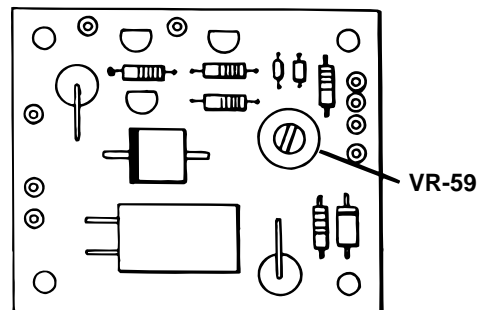

**Figure 6-8**

6-6. Switch-Over Relay

a. Switch-Over Relay in OFF Position

The Switch-Over Relay supplies the 24 volt input power from either the BATTERY or AC120V operating modes to the relay box for table operation. In the normal OFF position, BATTERY power is supplied to the relay box. See figure 6-9.

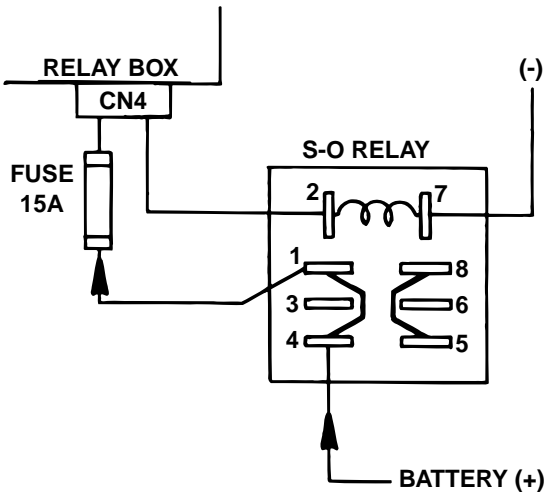

Figure 6-9. Relay in OFF Position

b. Switch-Over Relay in Activated Position

When the AC120V mode is activated by the main switch, a signal from the relay box activates the Switch-Over Relay. The relay then supplies the AC operating mode output power to the relay box and also activates the battery charging circuit. See figure 6-10.

**NOTE**

The battery charging circuit is only operational when the table is in the AC120V operating mode.

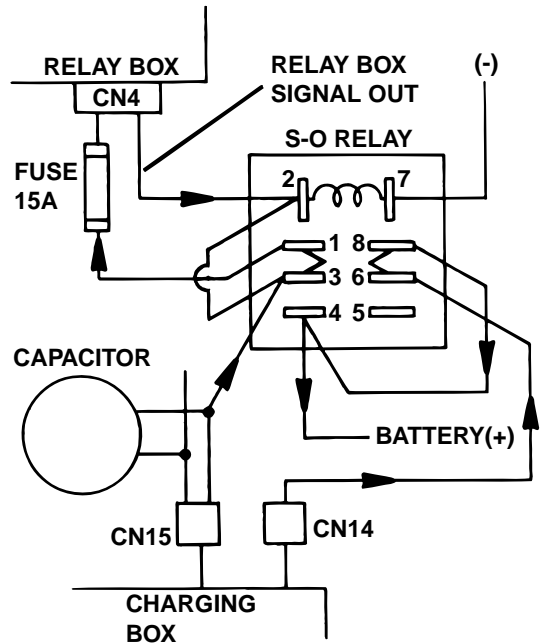

Figure 6-10. Relay in Activated Position

c. Switch-Over Relay Test

Using a DC voltmeter, test the operation of the relay in both the OFF (AC120V- OFF ) and Activated (AC120V - ON ) positions. See figure 6-11.

**NOTE**

The Switch-Over Relay mounting block may have to be removed from the base for test access.

OFF: (AC120V - OFF)

- term. 7(-) and term. 1(+) = 24 to 28VDC
- term. 7(-) and term. 6(+) = 0VDC

Activated: (AC120V - ON)

- term. 7(-) and term. 6(+) = 26.5±1VDC

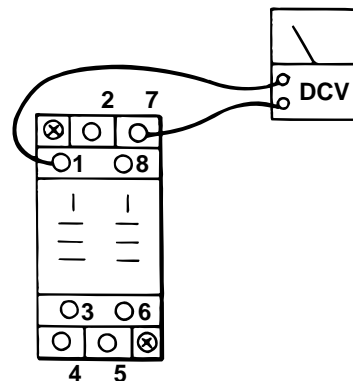

Figure 6-11. Switch-Over Relay

**6-7. Pendant Control**

The Pendant Control consists of 15 micro-switches (buttons). When any of the circuits are completed (by depressing a function button) the appropriate relay contacts (located in the relay box) close and a 24V potential is applied to the solenoid to operate the hydraulic mini-valve and to the hydraulic pump motor. The Pendant Control has 5 volts applied to it.

**a. Pendant Control Test**

The following test will determine if the micro-switches inside the Pendant Control are functioning correctly.

1. Unplug the 24 pin Pendant Control connector from the base of the table. You will be checking the cord side connector.
2. Use an ohmmeter R x 1 and check the continuity between pins 1 and pins 4 through 19 while pressing the appropriate button. Also test

between pins 21 and 22. See figure 6-12.

3. Ohmmeter must show continuity between the pins that are indicated when the appropriate buttons are pressed.

**NOTE**

Pins 2 and 3 are connected to the LEDs (AC120V and BATTERY indicator lights on the pendant control) and cannot be checked with an ohmmeter. Pins 17, 18, 20, 23 & 24 are NOT USED.

**b. Test Results:**

If you do not receive continuity between any of the pins, either the micro-switch in the Pendant Control is defective or a wire is broken. Either of these problems can be repaired easily.

If you receive correct readings with the meter, there is nothing wrong with the Pendant Control.

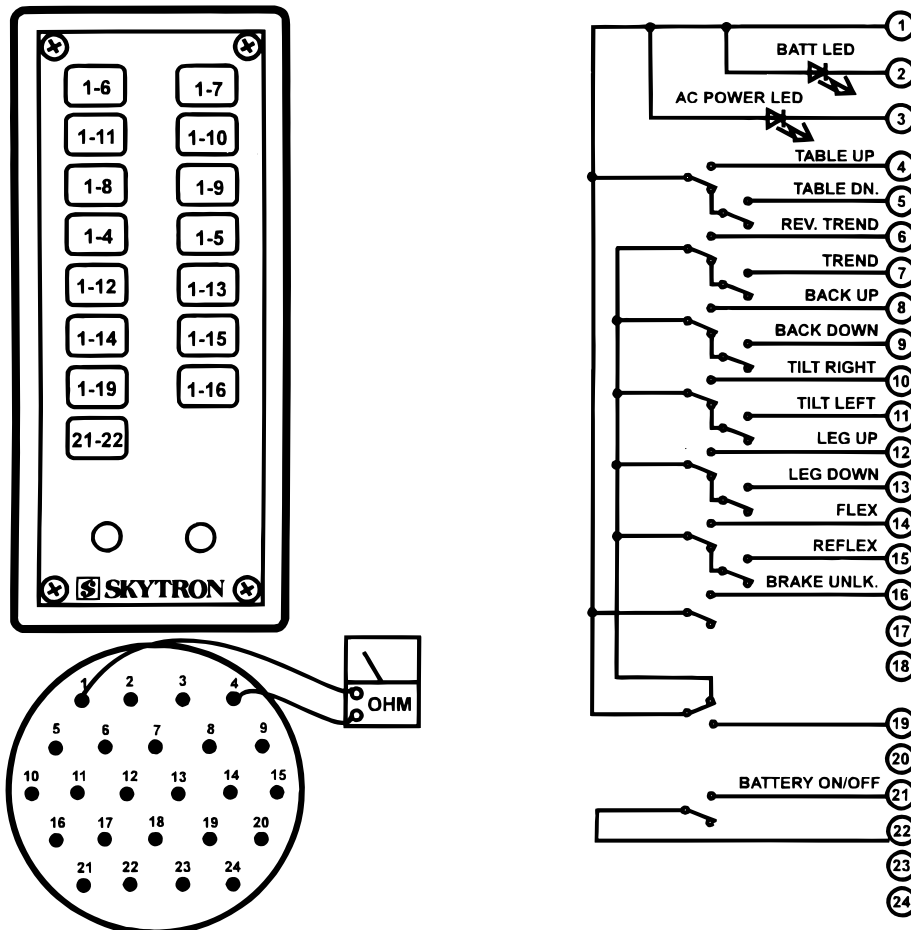
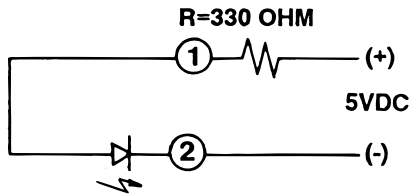

Figure 6-12. Pendant Control Test

**c. LED Test**

The BATTERY and AC120V power ON indicators can be checked with an LED tester. Test BATTERY indicator at pin 1(+) and pin 2(-) of 24 pin Pendant Control connector. Test AC120V indicator at pin 1(+) and pin 3(-). See figure 6-12.

If no LED tester is available the LEDs can be tested by applying 5 volts to the appropriate pins. To avoid damage to the LED a 330 ohm resistor must be placed between the power source and the connector pins. See figure 6 -13.



**Figure 6-13. LED Test**

**d. Wiring Harness Test**

The following test checks the wires leading from the relay box connector to the 24 pin connector table socket. These wires apply low voltage to the pendant control buttons.

1. Activate the AC120V operating mode.
2. Disconnect the pendant control from the table base connector. All other connectors should be connected.
3. Use a DC voltmeter and measure the following pins located in the 24 pin table base connector CN13. See figure 6-14.

**NOTE**

- A fine wire or a paper clip may be needed to accurately test the small sockets in the connector. The connector is low voltage and there is no danger of electrical shock.
- Pin 19 will have no voltage potential unless one of the return-to-level micro-switches are activated.

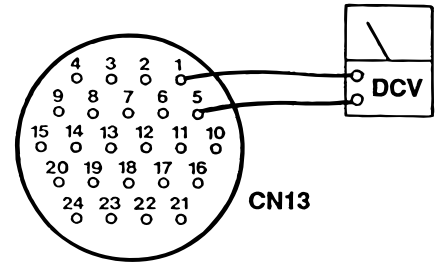

+ TEST LEAD	-TEST LEAD	DC VOLTS
1 21	3 - 16, 19 22	5.5 24

**Figure 6-14. Table Base Connector**

**e. Test Results:**

If you do not receive the correct voltage reading, the wiring or connector pins may be faulty. Disconnect connector CN1 from the Relay Box and using an ohmmeter, test the continuity between the corresponding pins in connectors CN1 and CN13. See figure 6-15. If the correct readings are obtained, this part of the circuit is okay and the problem may be the relay box.

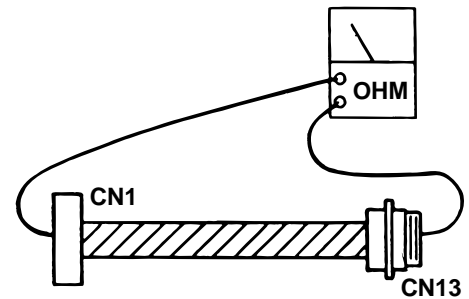

CN - 14 PIN NO.	CN - 1 WIRE COLOR	CN - 14 PIN NO.	CN - 1 WIRE COLOR
1	Red/White	12	Gray
2	White	13	White/Gray
3	Black	14	White/Yellow
4	Red	15	Purple/White
5	White/Red	16	Black/White
6	Yellow	17	Purple
7	Brown	18	White/Purple
8	White/Brown	19	Blue/Green
9	Blue/White	20	Brown/White
10	Orange	21	Blue/Purple
11	White/Orange	22	

**Figure 6-15. Base Connector Continuity Test**

6-8. Auxiliary Switches

The following tests will determine if the auxiliary switches are functioning properly.

a. Switch Test

Disconnect connector CN9 at the Relay Box and using an ohmmeter check for continuity at the connector pins (pin 1A common) while activating the appropriate switch. See figure 6-16. Meter should read 0 ohms.

b. Test Results

If proper meter readings are not received, test the individual switches as necessary. Using an ohm-

meter, test the operation of an individual switch with the (+) test lead at the center terminal of the switch and the (-) test lead at the terminal opposite the direction of the switch actuation. See figure 6-17. Meter should read 0 ohms. If the switches check out, the problem would have to be in the wires or connector CN9.

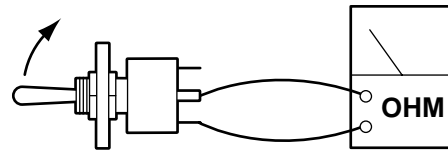
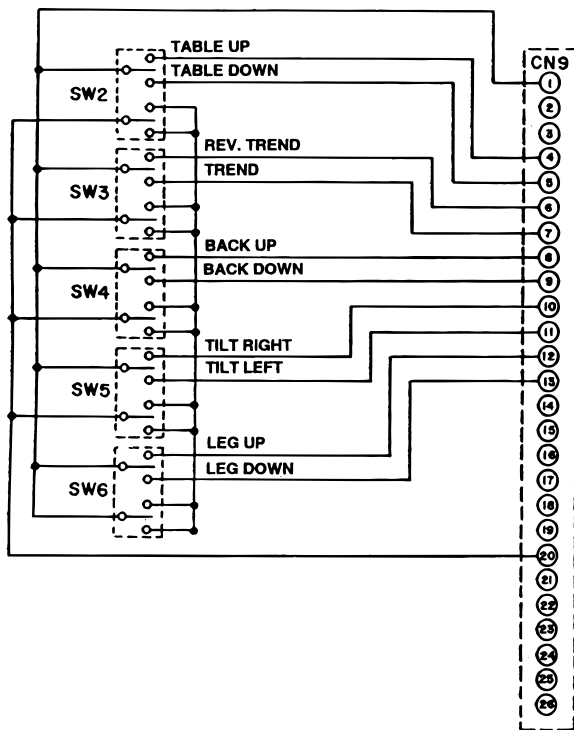
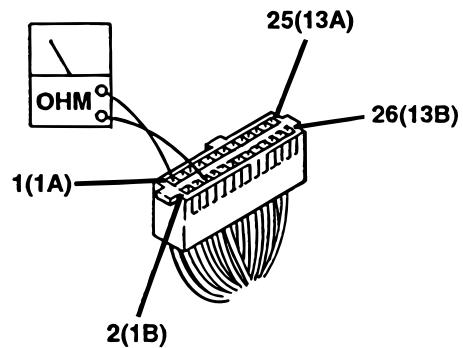
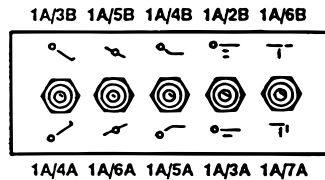

Figure 6-17. Auxiliary Switch Test



PIN NO.	COLOR	PIN NO.	COLOR
1(1A)	Red/White	14(7B)	
2(1B)		15(8A)	
3(2A)		16(8B)	
4(2B)	Red	17(9A)	
5(3A)	White/Red	18(9B)	
6(3B)	Yellow	19(10A)	
7(4A)	White/Yellow	20(10B)	White/Black
8(4B)	Brown	21(11A)	
9(5A)	White/Brown	22(11B)	Purple/White
10(5B)	Orange	23(12A)	
11(6A)	White/Orange	24(12B)	
12(6B)	Grey	25(13A)	
13(7A)	White/Grey	26(13B)	

Figure 6-16. Auxiliary Switch Connector CN9

### 6-9. Relay Box

The power supply is directly connected to the relay contacts. When these contacts are closed, 24 volts is supplied to the solenoids which are mounted on the hydraulic mini-valves. One relay is used to supply power to the pump/motor and is always activated no matter what control function is selected. The brake locking circuit relay is also activated when any control function other than BRAKE UNLOCK is *initially* selected.

Also, inside the 6002B relay box is a step-down transformer and full-wave rectifier which decreases the voltage to 5-6 volts. This low voltage potential controls the relays by the use of the hand-held pendant control buttons. Basically the relays enable a 5-6 volt potential to control the 24 volt circuit.

The following tests will determine if the relay box is functioning correctly.

#### a. Checking Relay Box Input Power

1. Plug the power cord into the 120VAC supply (wall receptacle). Disconnect connector CN4, leave all other connectors connected.
2. Using a DC voltmeter, test input power for both the BATTERY and AC120V operating modes. See figure 6-18. Meter should read approximately 24-28 volts.

BATTERY mode	AC120V mode
pin 1=(+)	pin 5=(+)
pin 2=(-)	pin 6=(-)

**Connector CN4 Color Code**

Pin 1 Red	Pin 5 White
Pin 2 Blue	Pin 6 Black
Pin 3 Yellow	Pin 7 Yellow
Pin 4 Blue	

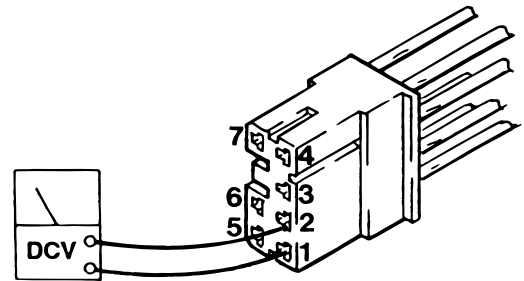

Figure 6-18. Relay Box Input

#### b. Test Results:

If you do not receive the correct meter readings, the problem is in the input wiring, connectors or components. If the correct readings are obtained, proceed to the next step.

#### c. Checking Output to Pump

1. Disconnect pump connector CN12, connect all other connectors and activate the AC120V operating mode.
2. Test CN12 at pin 1(+) and pin 2(-) with a DC voltmeter. Meter should read approximately 24-28 volts when any function button is activated. If no voltage is present, use an ohmmeter to test the continuity from CN12 to CN4 (yellow and blue wires). Refer to figure 6-18 for pin locations.

**d. Checking Output to Pendant Control**

**NOTE**

The Relay Box connectors CN1 (Pendant Control), and CN8 (Auxiliary Base Connector), are interchangeable.

1. Disconnect the Pendant Control connector from the base connector, connect all other connectors and use a DC voltmeter to measure the following sockets located in the table base connector CN13. See figure 6-19.

**NOTE**

- A fine wire or a paper clip may be needed to accurately test the small sockets in the connector. The connector is low voltage and there is no danger of electrical shock.

- To make sure all operating modes are OFF, connect the pendant control, turn AC120V power OFF at the main switch, wait approximately 5 seconds to make sure BATTERY operating mode is not activated and disconnect the pendant control.

2. With the AC120V and BATTERY operating modes in the OFF position, test connector CN13 at pin 1(+) and pins 2 through 16(-). Meter should read 0VDC. Test at pin 21(+) and 22(-), meter should read 24-28VDC.

3. With AC120V power ON (Main Power Switch activated), test connector CN13 at pin 1(+) and pins 3 through 16(-). Meter should read 5-6VDC.

4. Activate BATTERY operating mode by switching Main Power Switch OFF and momentarily placing a jumper wire between pin 21 and pin 22. Test pin 1(+) and pins 2 through 16(-). Meter should read 0VDC for pin 3; 5-6VDC for pins 2 and 4 through 16.

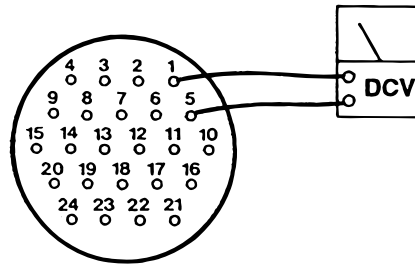

+ TEST LEAD	- TEST LEAD	DC VOLTS
1 21	AC 120V - OFF 3 - 16 22	5.5 44
1	AC 120V - ON 3 - 16	5.5
(+)	W/JMPR WIRE 21 - 22 (-)	v
1 1 1	2 3 4 - 16	5.5 0 5.5

**Figure 6-19. Table Base Connector CN13**

**e. Test Results:**

If you do not receive the correct meter readings, the relay box or wiring is defective. Test appropriate wires and connectors as necessary. If the correct readings are obtained, this part of the relay box is okay. Proceed to the next step.



## f. Checking Output to Solenoids

This test checks the voltage that is used to energize the solenoids.

1. Activate either BATTERY or AC120V operating mode.

### NOTE

- The Brake Lock function is activated by pressing any function button (except BRAKE UNLOCK). A timer in the Relay Box allows continuous output for about 7 seconds. If the brakes are already locked, no output is provided.
- The BRAKE UNLOCK button activates another timer in the relay box which allows continuous output for the brake release function for approximately 7 seconds. If the brakes are already released (using the BRAKE UNLOCK button) no output is provided.

2. Test connectors CN6 and CN7 from the back while attached to the relay box. All connectors should be connected.

3. Activate each of the pendant control buttons and measure the output voltage for the corresponding connector pins with a DC voltmeter. See figure 6-20.

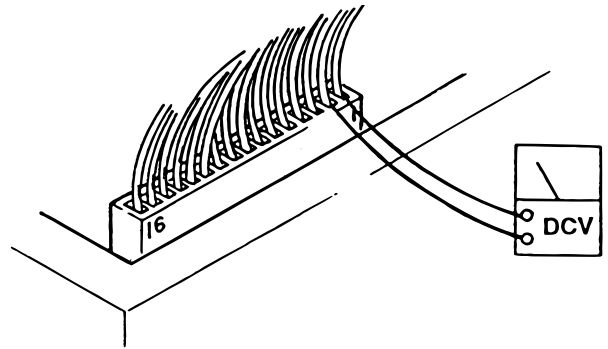

CN6			
OPERATION BUTTONS	+ TEST LEAD	- TEST LEAD	DC VOLTS
Table Up	1	2	24
Table Down	3	4	24
Trend	5	6	24
Rev Trend	7	8	24
Back Up	9	10	24
Back Down	11	12	24
Tilt Right	13	14	24
Tilt Left	15	16	24

CN7			
OPERATION BUTTONS	+ TEST LEAD	- TEST LEAD	DC VOLTS
Leg Up	1	2	24
Leg Down	3	4	24
Brake Set	9	10	24
Brake Unlock	11	12	24
Flex	13	14	24
Reflex	15	16	24

Figure 6-20. Connector CN6 or CN7

## g. Test Results:

If you do not receive the correct meter readings, the relay box is defective and should be replaced.

### NOTE

- Before deciding the relay box is defective, check the wires and pins in the connector blocks to make sure they are not loose or making a bad connection with their mate.
- If the battery power is ON and no table functions have been activated for 3 hours, the power off circuit will interrupt the battery power.

**6-10. Main Wire Harness Continuity Tests**

If correct meter readings are not received in tests between components, before replacing the components, test the Main Wire Harness to be sure all connectors and wires are making a good connection.

**a. CN4 to Batteries Test**

1. Disconnect connectors CN4 and the (+) and (-) connectors from the batteries. Leave all other connectors connected.

2. Using an ohmmeter, test for continuity between pin 1 of CN4 and battery (+) connector. Also test between pin 2 of CN4 and battery (-) connector. See figure 6-21.

**NOTE**

The 15 amp battery protection fuse is in the line between CN4 pin 1 and the battery connector. Test the continuity of the fuse if correct meter reading is not received.

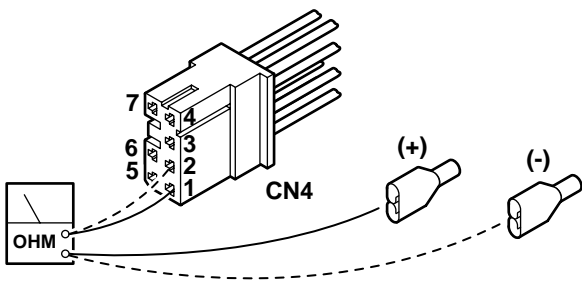
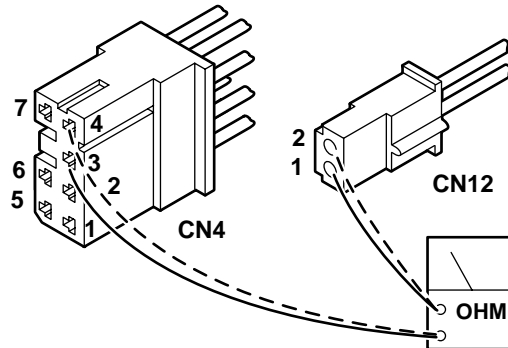

**Figure 6-21.**

**b. CN4 to CN12 Test**

1. Disconnect connectors CN4 and CN12. Leave all other connectors connected.

2. Using an ohmmeter, test for continuity between pins 3 and 4 of CN4 and pins 1 and 2 of CN12. See figure 6-22.



CN-4	CN-12	OHMS
3	1	0
4	2	0

**Figure 6-22.**

**c. CN4 to Charging Box Test**

1. Disconnect connectors CN4, CN11 and CN51. Leave all other connectors connected.

2. Using an ohmmeter, test for continuity between pins 4, 5 and 6 of CN4, pins 1 and 2 of CN11, and pin 4 of CN51. See figure 6-23.

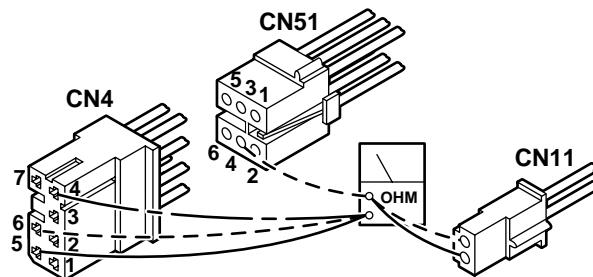

CN-11	CN-4	CN-51	OHMS
1	5		0
	6	4	0
2	4		0

**Figure 6-23. CN4, CN11, and CN51**

6-11. Solenoids

The solenoids are energized by 24 volt potential that is controlled by the relay box.

The solenoid windings are protected from excessive heat by an internal thermal fuse that will open after approx. 7 minutes of continuous operation. The solenoid must be replaced if the internal thermal fuse has been blown.

The solenoids are mounted directly on either side of the hydraulic mini-valves and push the spool valve in one direction or the other depending upon which solenoid is activated.

a. Solenoid Test

The following tests will check the voltage applied to the solenoids and the resistance of the solenoid coil.

b. Test #1

1. Activate either BATTERY or AC120V operating mode.
2. Disconnect the 2 pin connector from the solenoid in question, all other connectors should be connected. See figure 6-24.
3. Use a DC voltmeter and measure the voltage across the 2 pin connector. Pin 1(+), and pin 2(-). Meter should read approximately 24-28 volts.

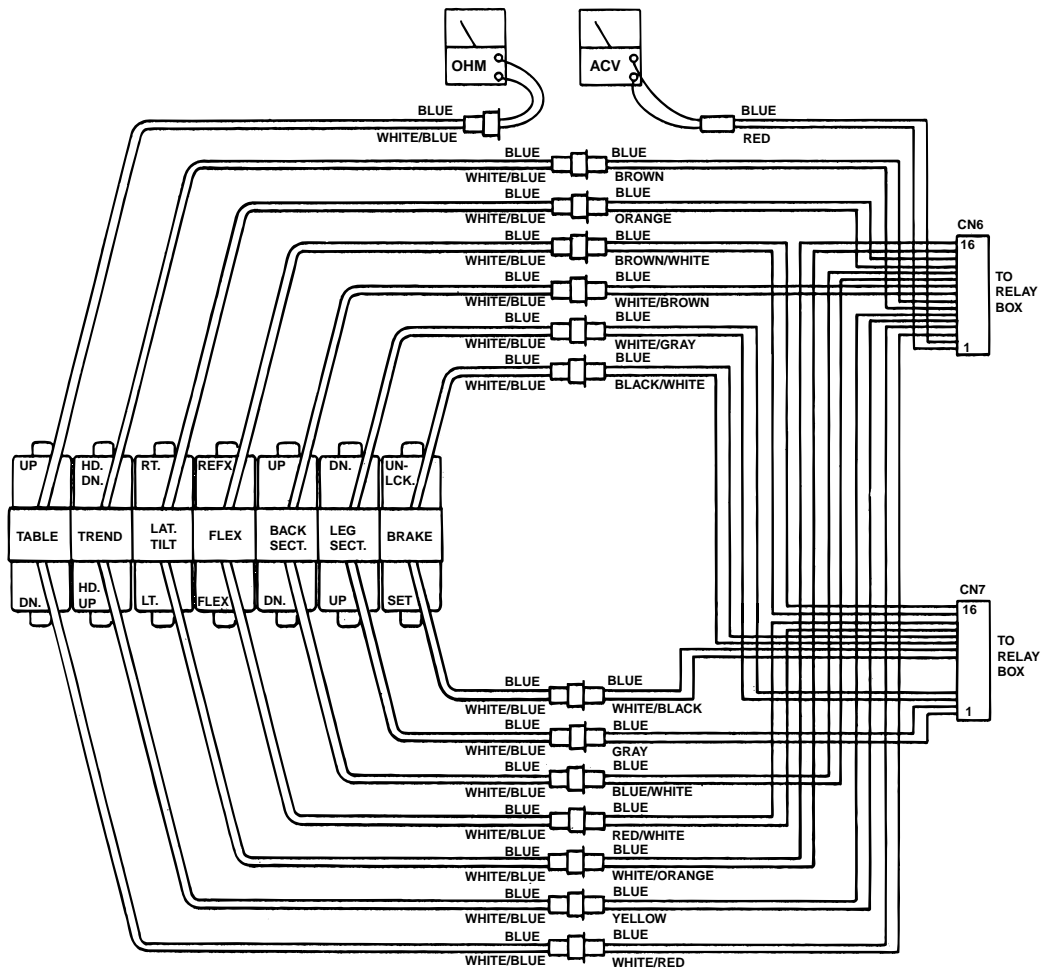

Figure 6-24. Solenoid Test

**NOTE**

- The appropriate pendant control button must be pushed during this test. The motor will run when this test is performed, and the brake locking solenoid will be activated by any function other than MOVE.

- If a solenoid does not function when the pendant control button is pushed, the problem could be the pendant control, the relay box, or the solenoid.

**c. Test Results:**

If you do not receive the correct voltage, the problem could be in the wires leading down to the connector. The problem could also be in the relay box or the Pendant Control (refer to appropriate section for troubleshooting).

If the correct voltage is obtained, everything is good up to that point and the problem is more than likely the solenoid.

**d. Test #2**

The solenoid can be checked out using an ohm-meter R x 1 scale.

1. Measure the resistance between the two pin connector in question as shown in figure 7-24. Connector must be disconnected. Polarity of meter leads is not important.

2. The meter should read approximately 16 ohms at room temperature.

3. Measure the resistance between either pin and ground.

4. Meter should read infinity.

**e. Test Results:**

If the solenoid does not check out with the meter, it is more than likely defective and must be replaced.

**NOTE**

Whenever there are several components of the same type, a defective unit can also be detected by substituting a known good unit or wire connector. In some cases this may be faster than using a multi-meter.

## 6-12. Motor/Pump Assembly

The hydraulic pump motor is a 24 volt DC electric motor. The oil pump unit is attached to the bottom of the motor and is a gear type displacement pump with a pumping capacity of .4 liter per min. The Motor/Pump Assembly is mounted on insulators in the base of the table.

### a. Motor/Pump Test

1. Disconnect motor connector CN12. Leave all other connectors connected and activate either BATTERY or AC120V operating mode.

2. Activate any function and use a DC voltmeter to measure across the two pin connector. Pin 1(+) and pin 2(-). See figure 6-25. Meter should read 24-28 volts.

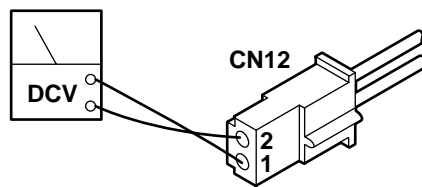

Figure 6-25. Motor Input Voltage

### NOTE

If the pump has been activated continuously for 1-1/2 to 2 minutes, the thermal relay will interrupt the power to the pump.

### b. Motor Resistance Test

The motor can be statically checked for resistance using an ohmmeter. This test is not 100% accurate because you are checking the motor with very low voltage from the meter and without any load.

1. Using an ohmmeter R x 1 scale, measure the resistance between the two pins of CN12. See figure 6-26.

2. The meter should read 1 to 2 ohms at room temperature.

3. Measure the resistance between either pin and ground.

4. Meter should read infinity.

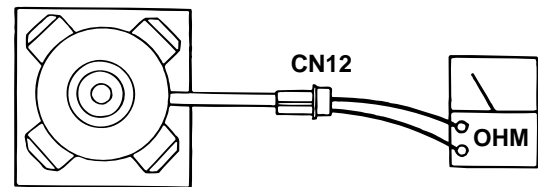

Figure 6-26. Motor Connector CN12

### c. Test Results:

If you do not receive the correct meter readings, the motor or wiring is defective.

## SECTION VII ELECTRICAL SYSTEM ADJUSTMENTS

### 7-1. Relay Box Adjustments - Models 6002 & 6002B

The Relay Box contains variable resistors for adjusting the operating timers for the BRAKE SET and BRAKE UNLOCK functions. The Relay Box for the battery model tables (6002B) also has variable resistors for setting the Power Off timer and the battery recharge warning circuit. These timers are set at the factory and usually never need adjustment. If an adjustment is necessary, remove the relay box cover and use the following procedures. See figures 7-1 and 7-2.

#### a. Brake Release Timer

The Brake Release Timer is set for about 7 seconds and is controlled by the variable resistor VR1 on the relay box circuit board. Turn the adjuster clockwise to increase the operating time. Counterclockwise to decrease the operating time.

#### b. Brake Set Timer

The Brake Set Timer is set for about 7 seconds and is controlled by the variable resistor VR2 on the relay box circuit board. Turn the adjuster clockwise to increase the operating time. Counterclockwise to decrease the operating time.

#### c. Battery Low Voltage Indicator

When the battery voltage drops below 23.5 volts, the BATTERY power indicator will begin to "Flash" indicating low battery power. This circuit is controlled by the variable resistor VR3 and should be set at 23.5 volts. Turn the adjuster clockwise to increase the voltage at which the circuit is activated, counterclockwise to decrease.

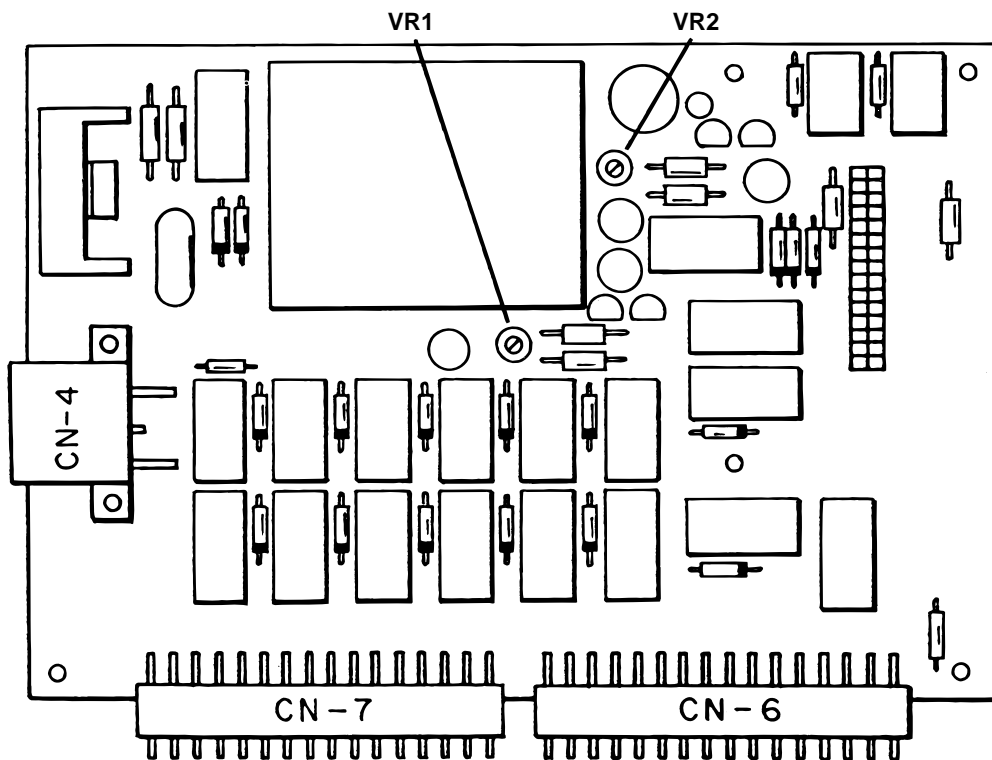

Figure 7-1. Relay Box Adjustments Model 6002

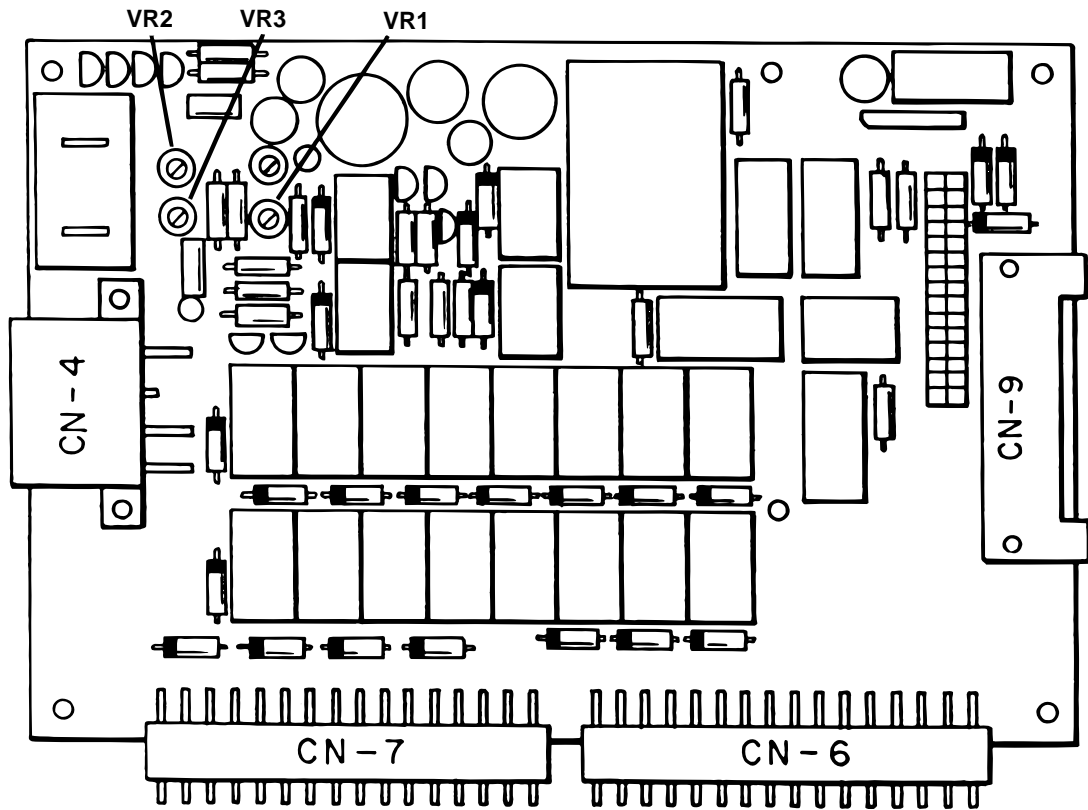

Figure 7-2. Relay Box Adjustments Model 6002B