

ELITE SERIES SURGICAL TABLES
OPERATORS MANUAL

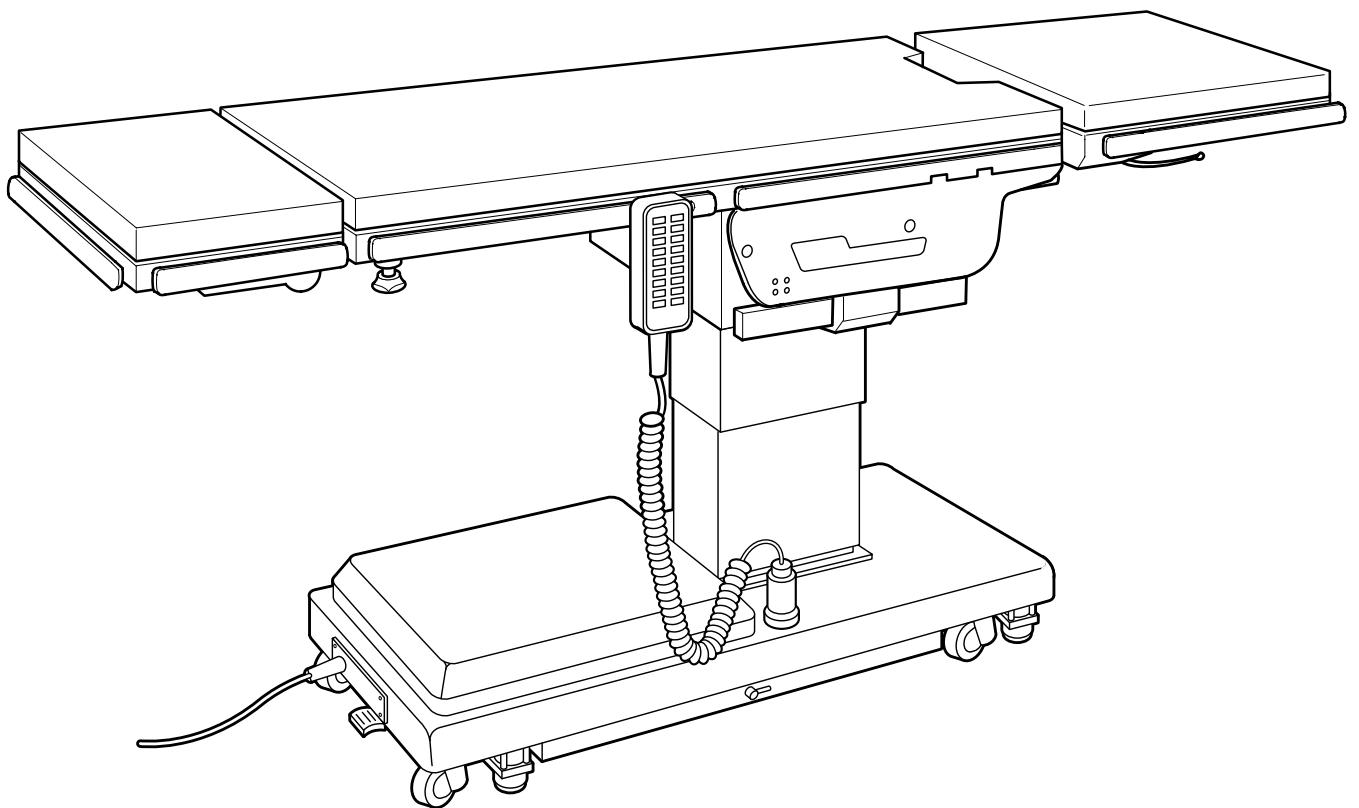

MODEL ELITE 3500
INCLUDING BATTERY MODELS

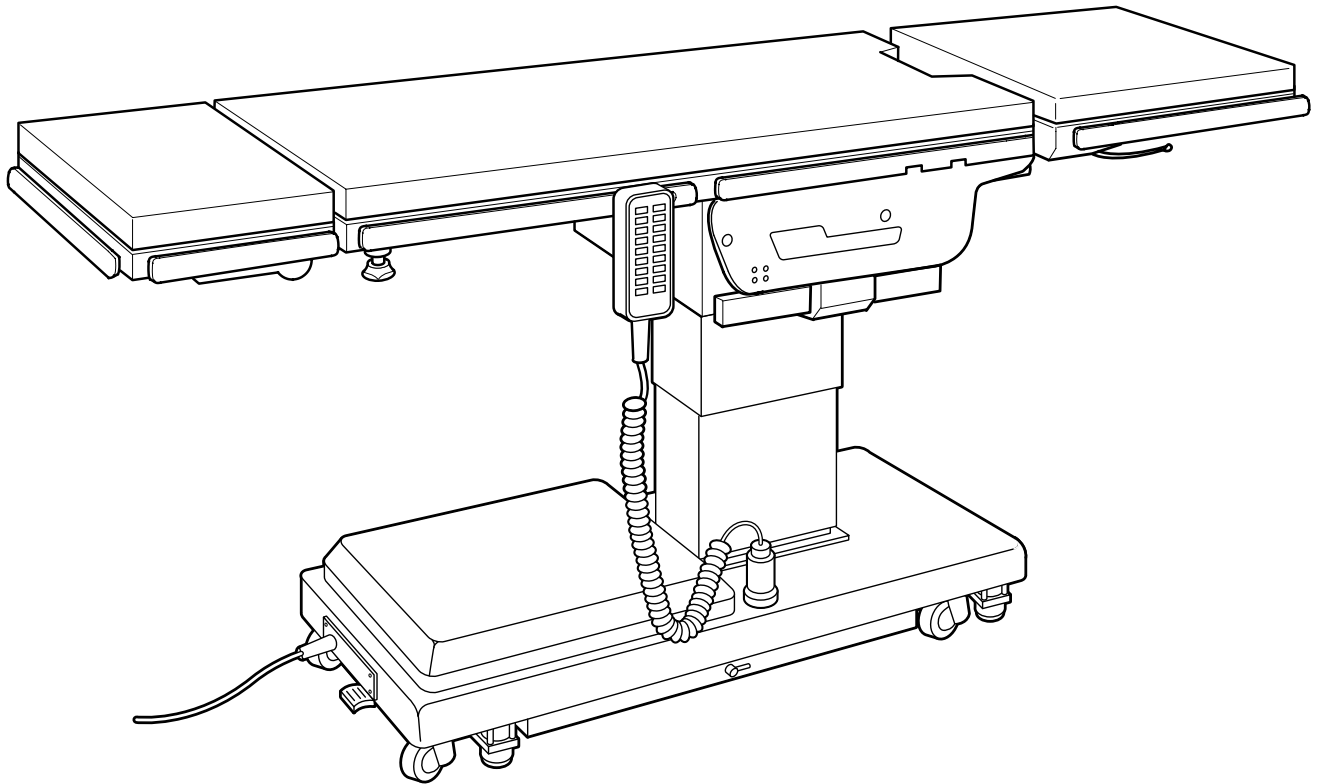

MODEL ELITE 3500

SKYTRON STANDARD LIMITED WARRANTY

SKYTRON, a Division of the KMW Group, Inc. (SKYTRON) warrants all new products sold by it directly or through a dealer or other authorized representative, with exception to replacement parts, spares, bulbs (surgical lights), pads, and accessory items (surgical tables) to be free from defects in material or workmanship, under normal use and service, for a period of two (2) years. This warranty shall include the cost of repair or replacement of defective parts including the cost of service labor and travel time to the site of equipment use. Delays caused by the user in accessing the equipment for repair will be chargeable at the normal hourly rate for service by SKYTRON's authorized service representative. The warranty period shall begin with the initial operation or one (1) year after receipt of the product, whichever shall occur first.

Replacement parts, spares, bulbs (surgical lights), pads and accessory items (surgical tables) are warranted to be free from defects in material or workmanship, under normal use and service, for a period of ninety (90) days from receipt by the ultimate user, with exception to replacement parts supplied by SKYTRON, for products under warranty, which shall be covered for any remaining period of the original product warranty, or for 90 days, whichever is of greater benefit to the ultimate user.

SKYTRON's responsibility and liability shall be limited to the repair or replacement of any part which we, SKYTRON, determine to be defective within the applicable warranty period. Minor adjustments required as a result of normal wear during the use of the product within the warranty period are not covered under warranty. The labor portion of this warranty is covered by SKYTRON's Authorized Service Agent. Repairs made by others are not authorized nor covered by SKYTRON with respect to labor costs.

SKYTRON shall not be liable for any other expense, loss or damage, whether direct, incidental, consequential or exemplary arising in connection with the sale or use of or the inability to use SKYTRON products.

NO EXPRESS WARRANTY IS GIVEN BY SKYTRON WITH RESPECT TO ITS PRODUCTS EXCEPT AS SPECIFICALLY SET FORTH HEREIN. ANY WARRANTY IMPLIED BY LAW, INCLUDING ANY WARRANTY OF MERCHANTABILITY OR FITNESS FOR A PARTICULAR PURPOSE, IS EXPRESSLY LIMITED TO THE TWO-YEAR AND 90-DAY TERMS SET FORTH ABOVE. THE FOREGOING STATEMENTS OF WARRANTY ARE EXCLUSIVE AND IN LIEU OF ALL OTHER REMEDIES.

No dealer, agent, employee or other representative of SKYTRON is authorized to extend or enlarge this warranty.

REV. 10/02

Although current at the time of publication, SKYTRON's policy of continuous development makes this manual subject to change without notice.

TABLE OF CONTENTS

Title	Page
EQUIPMENT LABELS AND SPECIFICATIONS	2
3500 Series General Purpose Surgical Table Specifications	3
SPECIAL USER ATTENTION	4
SECTION I INTRODUCTION	7
1-1. General	7
1-2. Power Requirements	7
1-3. Pendant Control Unit	8
1-4. Floor Lock/Brake System	8
SECTION II LINE POWER MODEL OPERATION	9
2-1. Electrical Power	9
2-2. Positioning Functions	9
a. Floor Lock/Brake system	9
b. Trendelenburg	10
c. Lateral Tilt	10
d. Back Section	10
e. Elevation	11
f. Top Slide	11
g. Leg Section	11
h. Flex Positioning	12
i. Kidney Lift	12
j. Return To Level	12
2-3. Emergency Brake Release	12
2-4. Head Section	13
2-5. Leg Section Removal.	13
SECTION III BATTERY MODEL OPERATION	14
3-1. Battery Model Table, AC 120V Operation	14
3-2. Battery Operation	14
3-3. Automatic Shut-Off	15
3-4. Charging the Battery	15
3-5. Emergency Back-up Controls	15
3-6. Positioning Functions	16
a. Floor Lock/Brake system	16
b. Trendelenburg	16
c. Lateral Tilt	17
d. Back Section	17
e. Elevation	17
f. Top Slide	18
g. Leg Section	18
h. Flex Positioning	18
i. Kidney Lift	19
j. Return To Level	19
3-7. Emergency Brake Release	19
3-8. Head Section	20
3-9. Leg Section Removal.	20
3-10. Positioning.	21
SECTION IV MAINTENANCE	24
4-1. Preventive Maintenance	24
4-2. Cleaning Recommendations	24
4-3. Service	25

EQUIPMENT LABELS AND SPECIFICATIONS

10A

FUSE TYPE 10 AMP, FAST ACTING (FA)



INDICATES DANGEROUS VOLTAGE, 120 V, 60 Hz



CLASS I DEFIBRILLATION PROOF, TYPE B EQUIPMENT- IPX4 RATED.
INTERNALLY POWERED EQUIPMENT



PROTECTIVE GROUNDING.
IN ORDER TO ENSURE PROPER GROUNDING RELIABILITY,
THIS TABLE MUST BE CONNECTED TO A PROPERLY GROUNDED
HOSPITAL GRADE OUTLET.



CONNECTION FOR NEUTRAL CONDUCTOR SUPPLIED



UNIT TO BE USED ONLY IN SPECIFIED ENVIRONMENTAL CONDITIONS
TEMPERATURE: 15° - 30° C (60° -85° F)
HUMIDITY: 30% - 60% RELATIVE HUMIDITY, NON CONDENSING



AC VOLTAGE

IPX4

ENCLOSURE CLASS

V

VOLTAGE RATING OF THE UNIT

A

AMPERAGE RATING OF THE UNIT

HZ

FREQUENCY OF THE UNIT



ATTENTION, CONSULT MANUAL FOR FURTHER INSTRUCTIONS.
INDICATES SPECIAL USER ATTENTION.

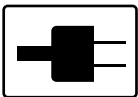

POWERED BY AC VOLTAGE

BATTERY MODELS

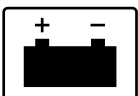

POWERED BY BATTERY

BATTERY TYPE: SEALED
LEAD ACID 12V, VALVE REGULATED
16AH, 10HR (530W/10MIN)

FUSE: **15A** 15 AMP FAST ACTING INTERNAL FUSE

3500 Series General Purpose Surgical Table Specifications

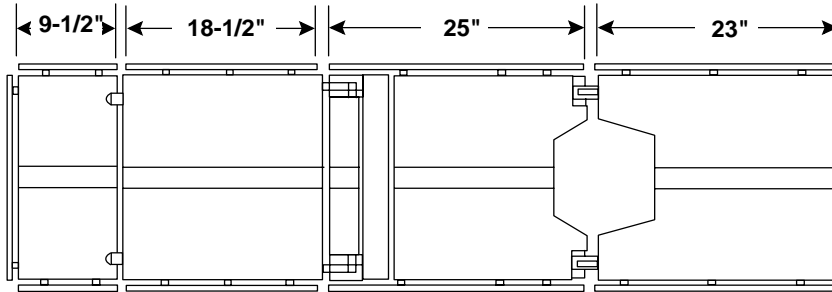

TOP VIEW

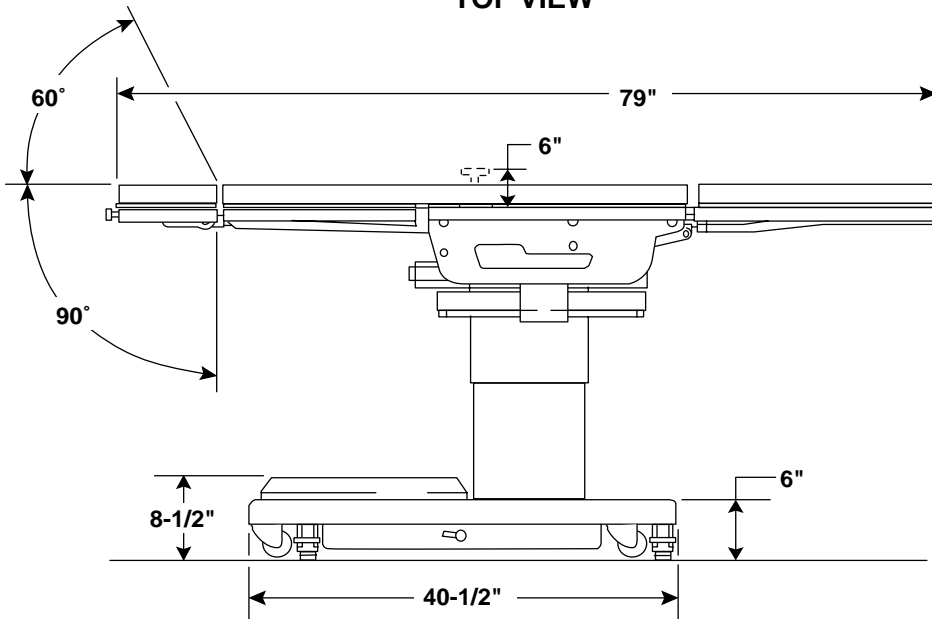

SIDE VIEW

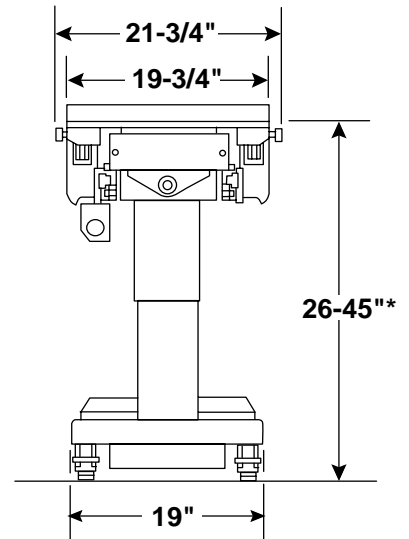

END VIEW

Electrical Specifications

Power requirements	120 VAC, 60Hz, 450 Watts
Current Leakage	Less than 100 micro amps
Power Cord	15 feet w/hospital grade connector (removeable on battery model)

ENTE LA CERTIFIED
 TO UL2601-1,
 CAN/CSA601.1, IEC 60601-2-46



SPECIAL USER ATTENTION

The extreme positioning capabilities of the 3500 Series Table requires special attention for possible interference points when using multiple function points. As with the operation of any surgical table, a certain amount of care should be exercised to position the patient safely. Although the thick pads and sheets substantially protect the patient, pinch points, located at the joints of the top section should always be considered. **BE SURE THAT THE ARMS, HANDS AND FINGERS OF THE PATIENT AND THOSE OF THE OPERATING ROOM PERSONNEL ARE CLEAR OF ALL MOVING PARTS BEFORE MOVING THE TABLE.** Proper restraints should always be used for patient safety.

Certain accessories such as the Uro-Drain Tray, Armboards and X-Ray top can be damaged when changing the position of the table top sections. Always look first to see if a desired movement is going to interfere with any accessories in use.

The operator has the ultimate responsibility of preventing damage to the table and surrounding equipment or possible injury to the patient or staff. In general, common sense will dictate when there is a potential hazard.

The following precautions should be reviewed by all personnel prior to operating the table.

A routine Instructional Program should be implemented by the facility for proper usage instructions for all personnel that may operate this table.



WARNING



Indicates a possibility of personal injury.



CAUTION



Indicates a possibility of damage to equipment.

NOTE

Indicates important facts or helpful hints.



WARNING



Risk of electrical shock. Make sure power cord is disconnected prior to accessing fuses.

NOTE

Activating any function button will activate the brake system. Using the TABLE-UP function to set the brakes provides a visual assurance that the brakes are locked. As the brake cylinders are extending, the entire table will move slightly. When the table top begins to elevate, the brakes are fully locked.



WARNING



DO NOT unlock brakes when a patient is on the table. An uneven patient weight load may cause instability.



WARNING



Prior to operating the table, observe all table caution labels and review the SPECIAL USER ATTENTION section in the front of this manual.



WARNING



DO NOT use the table in the presence of **FLAMMABLE GASES** (Flammable gases are not commonly used in the U.S.)

NOTE

The main power switch can be placed in the OFF position to completely deactivate all table functions if required during certain procedures or in case of emergency.

NOTE

With an evenly distributed patient weight load, all table positioning functions will operate smoothly and quietly with a patient weight of up to 500 pounds.



WARNING



DO NOT unlock brakes when a patient is on the table. An uneven patient weight load may cause instability.

**WARNING**

To maximize patient safety, utilize proper restraint methods during extreme Trendelenburg positioning.

**WARNING**

To maximize patient safety, utilize proper restraint methods during extreme lateral tilt positioning.

NOTE

If the table top is slid toward the foot end, the back section will not go below horizontal.

NOTE

To prevent damage to the kidney lift, a safety interlock prevents the back section from going up more than 45° if the kidney lift is not all the way down.

NOTE

If the leg section is positioned more than 45° below horizontal, the top will not slide toward the head end.

NOTE

If the back section is positioned below horizontal, the top will not slide toward the foot end.

**CAUTION**

The leg section may hit the table base or floor if both the leg and elevation systems are placed in their full down position.

NOTE

If the top is slid toward the head end, the leg section will only go down 45°.

NOTE

When FLEX button is activated and if the top is slid toward the foot end, the back section will not go below horizontal.

NOTE

To prevent damage to the kidney lift, a safety interlock prevents the kidney lift from going up if the back section is 45° above horizontal.

NOTE

Elevation, kidney lift, top slide and brake system functions are not affected by the return to level function.

NOTE

The Emergency Brake Release Valve must be closed and tightened (clockwise) before activating any function.

•If the Emergency Brake Release Valve has been operated, the UNLOCK button on the pendant control will have to be pressed before brakes will lock again.

**WARNING**

In the unlikely event that a procedure requires the reversal of the patient on the table top with the head section attached to the leg section, the patient weight limit is reduced to 300 pounds.

NOTE

The leg section with the x-ray top + pad attached weighs 31 lbs. It is recommended that the x-ray top and pad be removed before detaching the leg section.

NOTE

•Turning the Main Power Switch ON will change the table operation to 120 VAC power regardless of the position of the BATT button.

•If Battery operation is activated while Main Power Switch is ON there will be approximately a 4 second delay before Battery operation activates.

NOTE

The power cord may be removed from the table. The table will operate correctly on battery power with the power cord connected to a wall outlet or disconnected.

NOTE

Battery Operation must be turned OFF at the pendant control. It can not be turned Off using the main power switch.

NOTE

If the table is stored for a period greater than 6 months, the batteries should be removed and stored in a dry, clean condition at a storage temperature of 68° F (20° C). Batteries should be recharged every 6 months of product storage.

NOTE

•When the red light starts to blink (indicating low power in battery) the table will operate for approximately 5 continuous minutes, typically long enough to use the table for the rest of the day.

•The charging system operates ONLY when the table is in AC 120V mode.

NOTE

In battery mode, only the red indicator light will be on. In AC 120V mode, both the green indicator light and red indicator light will be on.

NOTE

The table can be operated on 120VAC power while the battery is being recharged.

NOTE

The emergency back-up control switches will function when the table is operating on 120VAC power, battery power, or turned off.



CAUTION



•The Emergency Release Valve must be closed and tightened (clockwise) before activating any hydraulic function.

•If the Emergency Brake Release Valve has been operated, the UNLOCK button on the pendant control will have to be pressed before brakes will lock again.



WARNING



Consult manufacturer's instructions when using high frequency surgical equipment, cardiac defibrillator and cardiac defibrillator monitors.



WARNING



When an antistatic pathway is required, the table has to be used on an antistatic floor.



WARNING



The antistatic properties of the table are dependent on the use of the original pad set which was furnished with the table or an alternate approved replacement.



WARNING



Certain accessories may limit weight capacities. Check with your SKYTRON representative.

NOTE

Always follow current AORN Journal Guidelines to ensure proper cleaning and disinfection procedure.



WARNING



Always follow OSHA blood-borne pathogens standards for protective clothing, including gloves, masks and eye protection when cleaning the surgical table.



CAUTION



Thoroughly read and follow the manufacturer's directions for all cleaning fluids. DO NOT use cleaners containing phenolics.



CAUTION



When using spray cleaners DO NOT spray fluids directly into electrical receptacles or micro switches.



CAUTION



Before replacing pads on the table, make sure the pads and all mating surfaces are completely dry. Moisture trapped between the pads and mating surfaces may cause distortion of table tops.

SECTION I INTRODUCTION

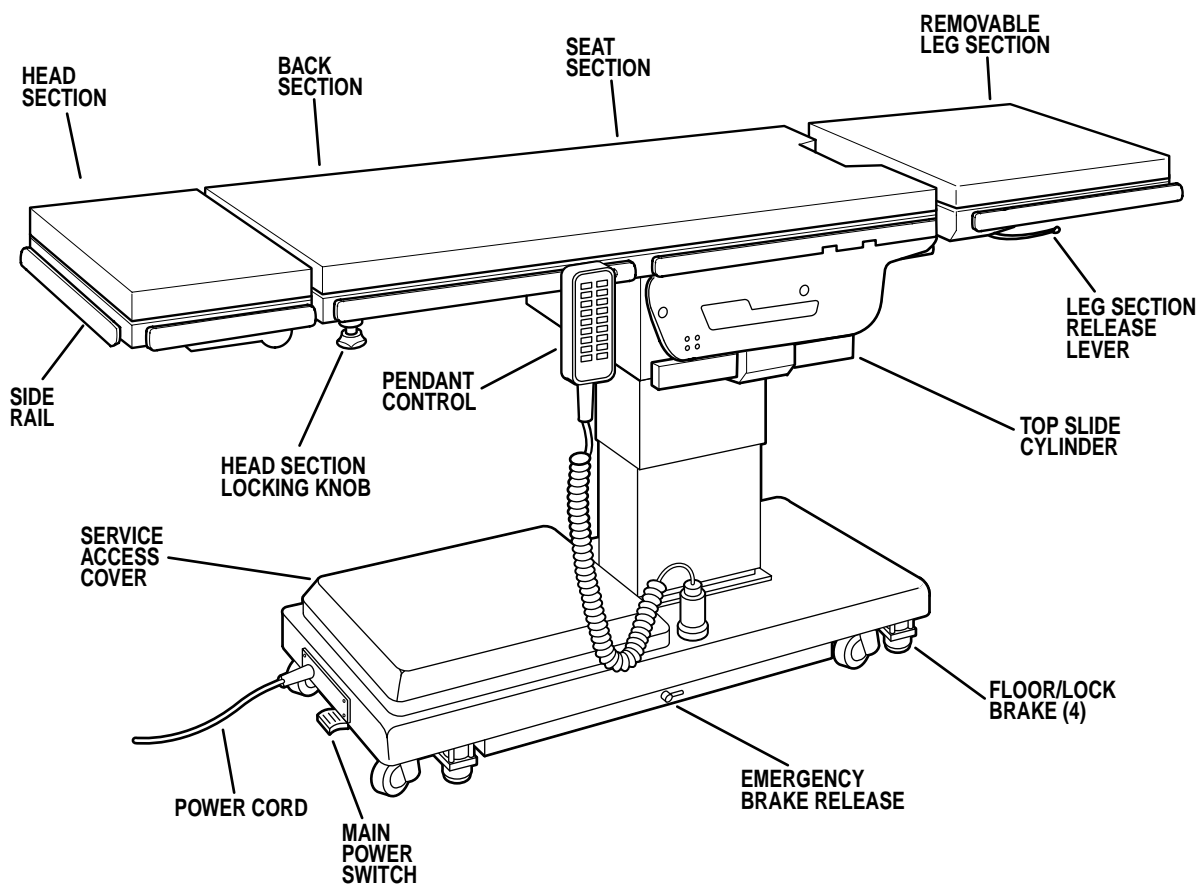

Figure 1-1. Elite 3500

1-1. General

SKYTRON's Elite 3500 Series Surgical Tables are electro-hydraulically operated, general purpose surgical tables. See figure 1-1.

The electro-hydraulic positioning functions operated by the hand-held, push button, pendant control unit are: trendelenburg, lateral tilt, back section, elevation, leg section, top slide, flex/reflex, kidney lift, return to level, and the floor lock/brake system.

Manual controls are provided for head section positioning, emergency brake release and leg section removal.

1-2. Power Requirements

The Elite 3500 Surgical Table requires a 120VAC, 60 Hz electrical power supply. The table is equipped with a 15 foot long power cord with a standard three prong, hospital grade plug. The electrical protection fuses (2) are located behind a cover plate in the

electrical enclosure on the front edge of the base. See figure 1-2. The main power ON/OFF switch is located on the electrical enclosure.



WARNING



Risk of electrical shock. Make sure power cord is disconnected prior to accessing fuses.

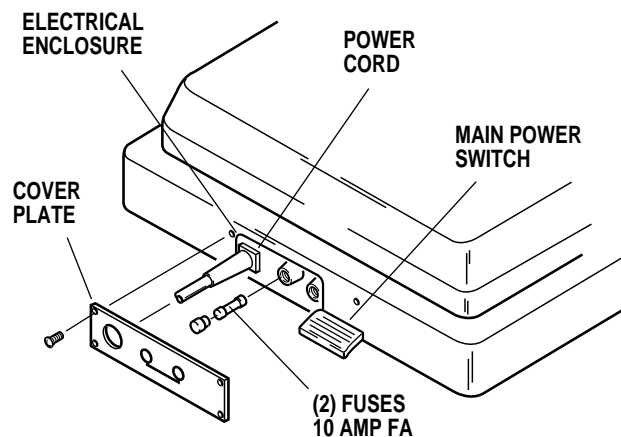

Figure 1-2. Power Switch and Fuse Location

1-3. Pendant Control Unit

The hand-held pendant control unit (figure 1-3) has a non-slip rubber cover which assures a positive grip during use. A spring clip hanger located on the back of the control allows it to be stored on the table side rails.

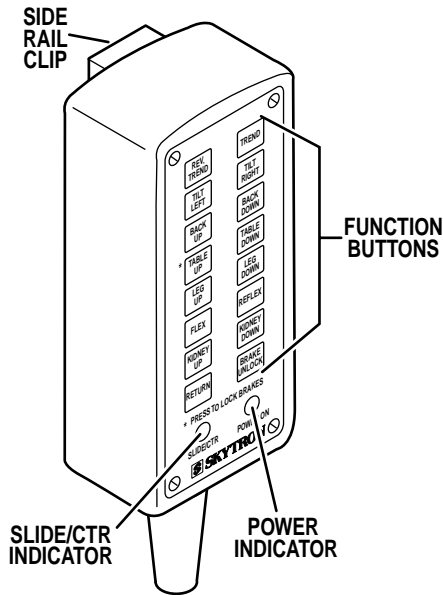

Figure 1-3. Pendant Control Unit

The function push buttons are identified with abbreviated descriptions for all functions. See figure 1-4. The trendelenburg and table-up buttons are red, the remaining buttons are all black.

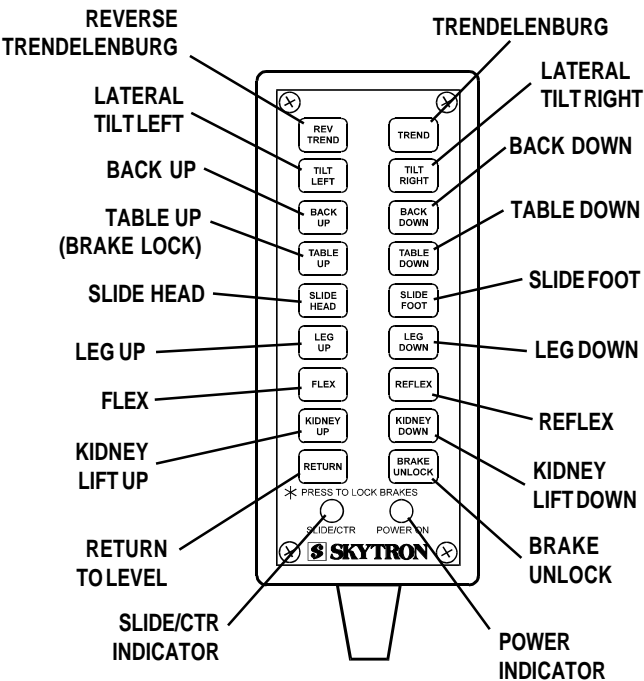

Figure 1-4. Function Push Buttons

1-4. Floor Lock/Brake System

The floor lock/brake system consists of four self-leveling, hydraulic brake cylinders which raise and support the table base off from the casters. Press the TABLE-UP button on the pendant control to set the table's brakes. An electronic timer in the brake circuit will activate the brake system until the brakes are completely set, approximately 8-10 seconds.

NOTE

Activating any function button will activate the brake system. Using the TABLE-UP function to set the brakes provides a visual assurance that the brakes are locked. As the brake cylinders are extending, the entire table will move slightly. When the table top begins to elevate, the brakes are fully locked.

To unlock the brakes, press the UNLOCK button and release. The brakes will retract automatically in approximately 7-8 seconds.



WARNING

DO NOT unlock brakes when a patient is on the table. An uneven patient weight load may cause instability.

SECTION II LINE POWER MODEL OPERATION

2-1. Electrical Power

a. Check to be sure the power cord is plugged into a properly grounded, Hospital Grade, 120VAC outlet. Make sure the power cord is routed so as to prevent it from being in the way of the operating personnel.



WARNING



Prior to operating the table, observe all table caution labels and review the SPECIAL USER ATTENTION section in the front of this manual.



WARNING



DO NOT use the table in the presence of FLAMMABLE GASES (Flammable gases are not commonly used in the U.S.)

b. Depress Main Power ON/OFF switch on the electrical enclosure. See figure 2-1. The green Power ON indicator light on the pendant control unit should now be illuminated.

NOTE

The main power switch can be placed in the OFF position to completely deactivate all table functions if required during certain procedures or in case of emergency.

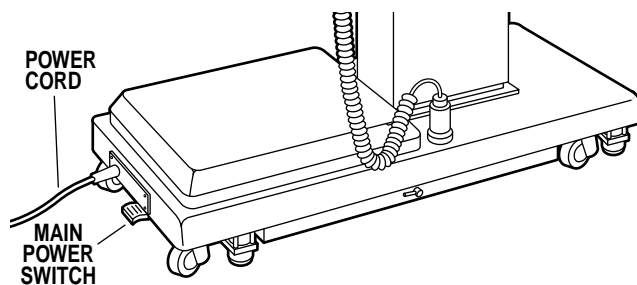

Figure 2-1. Main Power Switch

2-2. Positioning Functions

The hand-held pendant control unit (figure 2-2) activates the following table functions:

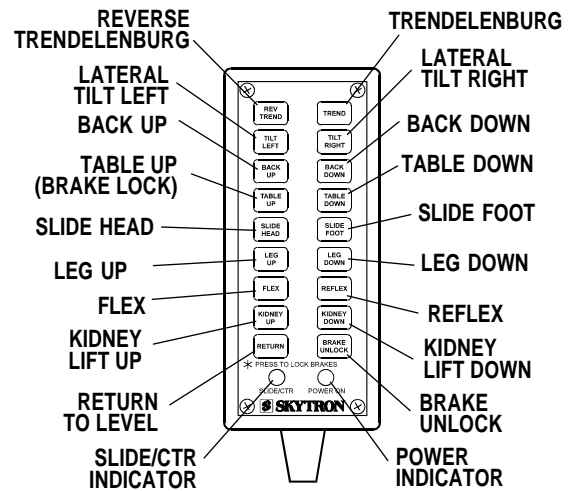

Figure 2-2. Pendant Control Unit

NOTE

With an evenly distributed patient weight load, all table positioning functions will operate smoothly and quietly with a patient weight of up to 500 pounds.

a. **Floor Lock/Brake System.** To activate the brakes without affecting table positioning, press the TABLE-UP button. See figure 2-3. The elevation cylinder will not function until the brakes are completely extended.

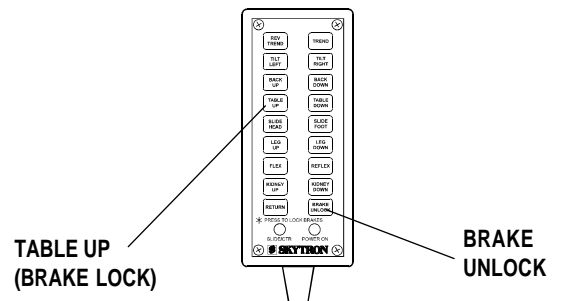

Figure 2-3. Brake System Activation

Press the BRAKE-UNLOCK button on the pendant control to release the four self-leveling brake feet in order to move the table. See figure 2-3. The brake delay circuit automatically retracts the brake system with just one press of the BRAKE-UNLOCK button. It takes approximately 7-8 seconds to totally release the system.



WARNING



DO NOT unlock brakes when a patient is on the table. An uneven patient weight load may cause instability.

b. Trendelenburg. To place the surgical table in a trendelenburg (head down) position, press the TREND button (figure 2-4). Trendelenburg positioning of up to 25° may be obtained. To place the table in a reverse trendelenburg (head up) position, press the REV TREND button. Reverse Trendelenburg positioning of up to 20° may be obtained.



WARNING



To maximize patient safety, utilize proper restraint methods during extreme Trendelenburg positioning.

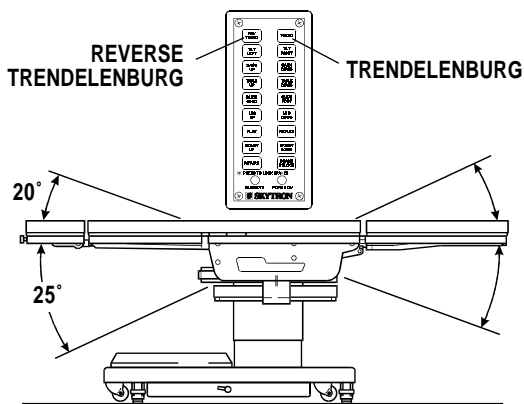

Figure 2-4. Trendelenburg Positioning

c. Lateral Tilt. To achieve lateral tilt right (as viewed from the head end of the table), press the TILT-RIGHT button (figure 2-5). Tilt of up to 20° may be obtained. To achieve lateral tilt left, press the TILT-LEFT button. Tilt of up to 20° may be obtained.



WARNING



To maximize patient safety, utilize proper restraint methods during extreme lateral tilt positioning.

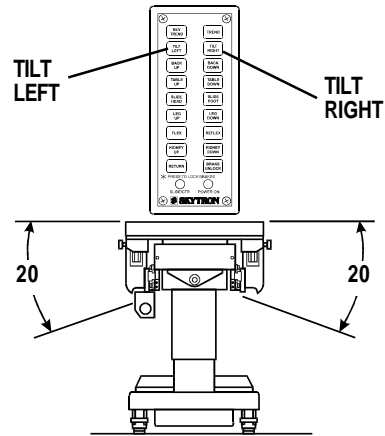

Figure 2-5. Lateral Tilt Positioning

d. Back Section. To raise the back section, press the BACK-UP button (figure 2-6). The back section will raise up to 90° above horizontal. To lower the back section, press the BACK-DOWN button. The back section will go down to 40° below horizontal.

NOTE

If the table top is slid toward the foot end, the back section will not go below horizontal.

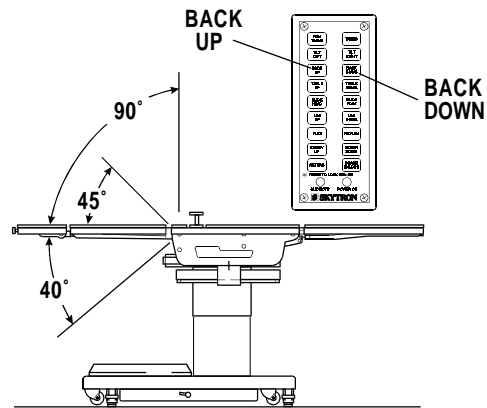

Figure 2-6. Back Section Positioning

NOTE

To prevent damage to the kidney lift, a safety interlock prevents the back section from going up more than 45° if the kidney lift is not all the way down.

e. **Elevation.** To raise table top, press the TABLE-UP button (figure 2-7.). The table will lift a patient weight of 500 pounds up to a maximum height of 45". To lower the table top, press the TABLE-DOWN button. The table top will go down to a minimum height of 26" (minus pad).

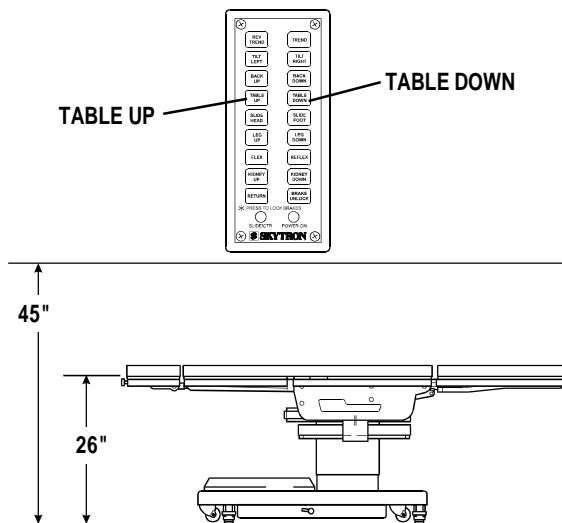

Figure 2-7. Elevation Function

f. **Top Slide.** To move the table top toward the head end, press the SLIDE HEAD button. From center position, the top will slide up to 7-1/2". See figure 2-8.

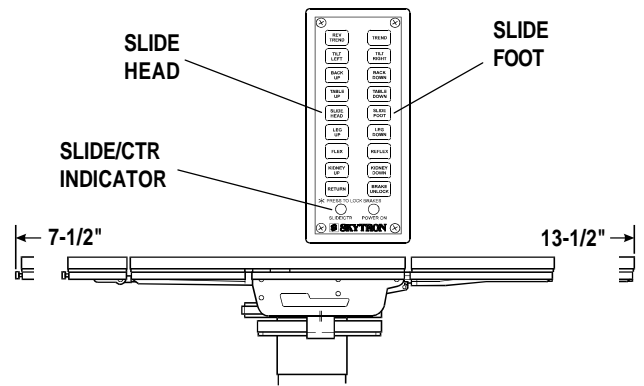

Figure 2-8. Top Slide

g. **Leg Section.** To lower the leg section, press the LEG-DOWN button (figure 2-9). The leg section will go down to 98° below horizontal. To raise the leg section, press the LEG-UP button. The leg section will go up to 2° above horizontal.

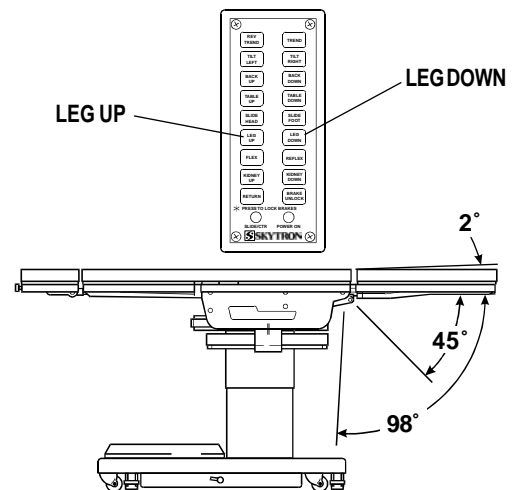

Figure 2-9. Leg Section Positioning

NOTE

If the leg section is positioned more than 45° below horizontal, the top will not slide toward the head end.

To move the table top toward the foot end, press the SLIDE FOOT button. From center position, the top will slide up to 13-1/2". Slide function will stop and Slide/Ctr Indicator will illuminate when table is centered.

NOTE

If the back section is positioned below horizontal, the top will not slide toward the foot end.



CAUTION



The leg section may hit the table base or floor if both the leg and elevation systems are placed in their full down position.

NOTE

If the top is slid toward the head end, the leg section will only go down 45°.

h. Flex Positioning. To place the table top in a flex position from horizontal, press the FLEX button (figure 2-10). To return the table top to a horizontal position or into a reflex position, press the RETURN or REFLEX button.

NOTE

When FLEX button is activated and if the top is slid toward the foot end, the back section will not go below horizontal.

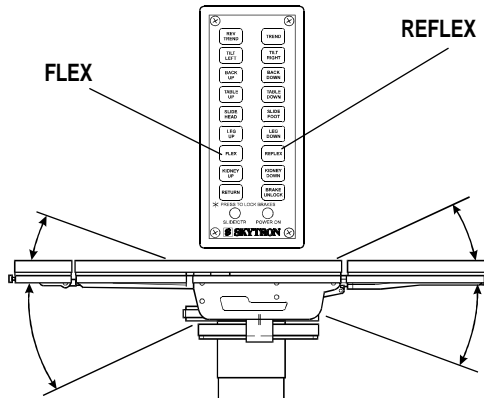

Figure 2-10. Flex/Reflex Positioning

i. Kidney Lift. To raise the built-in kidney lift, press the KIDNEY-UP button (figure 2-11). Up to 5-1/2 inches of lift can be achieved. Press the KIDNEY -DOWN button to lower the kidney lift.

NOTE

To prevent damage to the kidney lift, a safety interlock prevents the kidney lift from going up if the back section is 45° above horizontal.

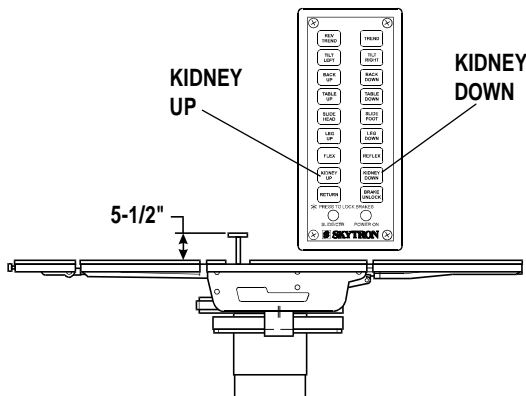

Figure 2-11. Kidney Lift Positioning

j. Return To Level. To return the table top to a level position, press the RETURN button (figure 2-12).

NOTE

Elevation, kidney lift, top slide and brake system functions are not affected by the return to level function.

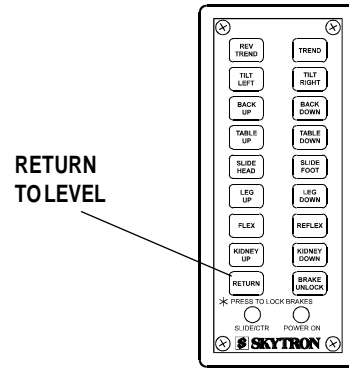

Figure 2-12.

2-3. Emergency Brake Release

In case of a power failure or an electrical problem within the table, the emergency brake release system can be used to move the table. The control lever for this function is located on the side of the table base and is identified by an EMERGENCY BRAKE RELEASE label. Turn the lever counter-clockwise to release the brakes. See figure 2-13.

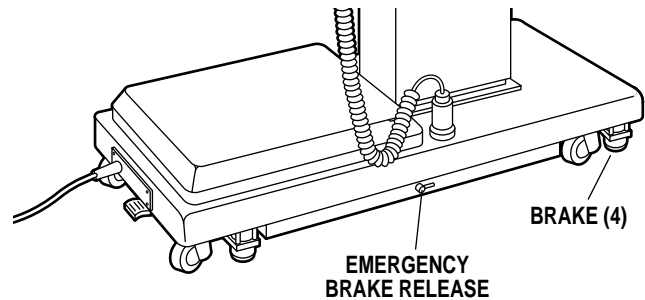

Figure 2-13. Emergency Brake Release

NOTE

The Emergency Brake Release Valve must be closed and tightened (clockwise) before activating any function.

- If the Emergency Brake Release Valve has been operated, the UNLOCK button on the pendant control will have to be pressed before brakes will lock again.

2-4. Head Section

a. A quick release positioning bar located under and to the front of the head section (figure 2-14) is used to raise or lower the head section. Pull the release bar toward the head end to allow the section to pivot up or down. Positioning from 60° above horizontal to 90° below horizontal in 15° increments is available. Release the bar to lock the head section in position.

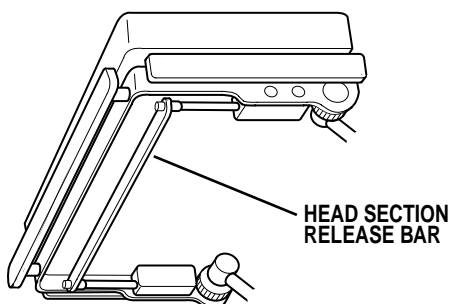

Figure 2-14. Head Section Adjustment

b. By loosening two locking knobs beneath the back section, an additional 5" of longitudinal adjustment can be achieved. If desired, the head section may be removed by loosening the locking knobs and pulling it straight out of the back section. 3500 Series Tables have the capability of attaching the head section to the leg section for use as a foot extension. Two locking knobs are located on the inside of the leg section for securing the head section. See figure 2-15.

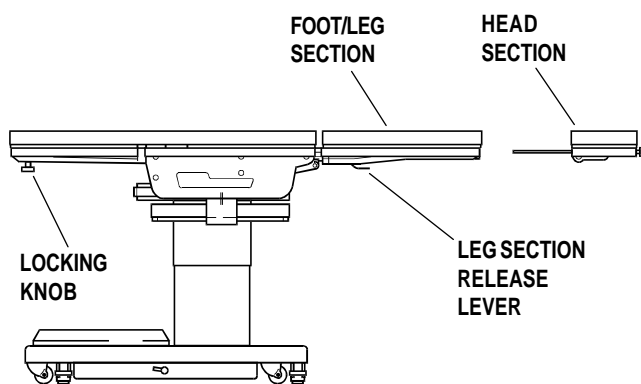

Figure 2-15. Repositioning Head Section



WARNING



In the unlikely event that a procedure requires the reversal of the patient on the table top with the head section attached to the leg section, the patient weight limit is reduced to 300 pounds.

2-5. Leg Section Removal.

NOTE

The leg section with the x-ray top + pad attached weighs 31 lbs. It is recommended that the x-ray top and pad be removed before detaching the leg section.

a. To remove the leg section, simultaneously depress both release levers and pull the leg section out. See figure 2-16. Press the LEG-DOWN button on the pendant control to position the leg section attachment pins down and out of the way.

b. To Install Leg Section, press and hold the LEG-UP button until the leg section attachment pins completely stop before reinstalling the leg section to the table. Pull out on the leg section after installation to make sure the release levers are completely locked.

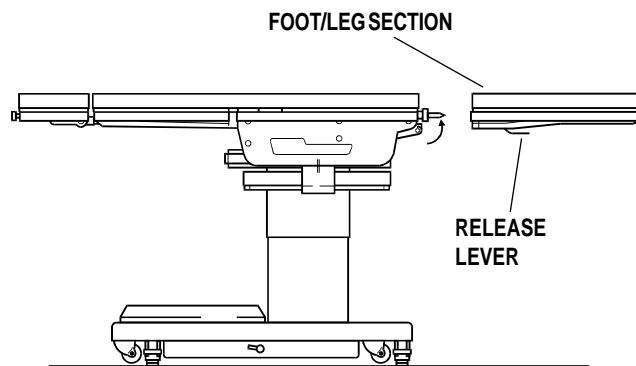

Figure 2-16. Leg Section Release Levers

SECTION III BATTERY MODEL OPERATION

3-1. Battery Model Table, AC 120V Operation

a. Be sure the power cord is plugged into a properly grounded, Hospital Grade, 120VAC outlet. Make sure the power cord is routed to the outlet to prevent it from being in the way of operating personnel.

b. Depress the main power ON/OFF switch located on the electrical enclosure. See figure 3-1. The green AC 120V, Power-On indicator light located in the upper right corner of the pendant control will illuminate. See figure 3-2.

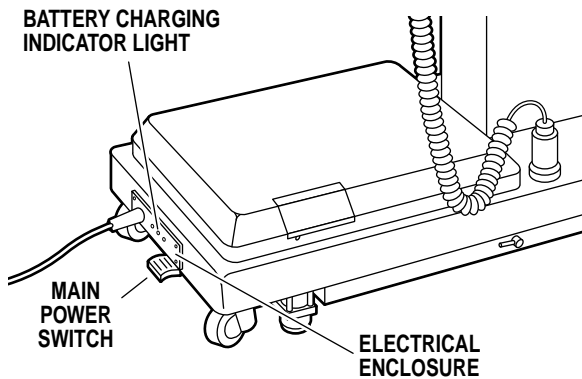

Figure 3-1. Main Power Switch

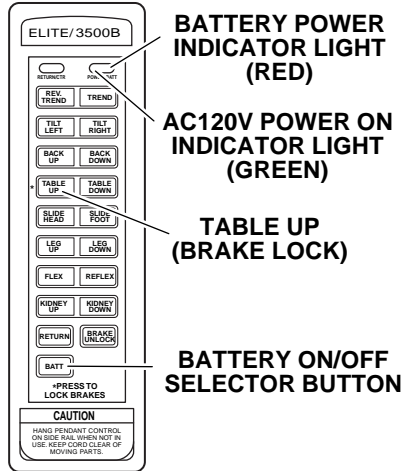

Figure 3-2. Pendant Control

c. The table is now ready for 120VAC operation. Press the TABLE UP button on the pendant control to set the table's brakes. An electronic timer will activate the brake system until the brakes are completely set, approximately 8-10 seconds. Press the desired function button to position the table.

NOTE

•If brakes fail to set, make sure the Emergency Brake Release Lever is tight (clockwise).

•If the Emergency Brake Release Valve has been operated, the BRAKE UNLOCK button on the pendant control will have to be pressed before brakes will lock again.

NOTE

•Turning the Main Power Switch ON will change the table operation to 120 VAC power regardless of the position of the BATT button.

•If Battery operation is activated while Main Power Switch is ON there will be approximately a 4 second delay before Battery operation activates.

3-2. Battery Operation

a. Make sure the green, AC 120V, Power-On indicator light, on the hand-held pendant control, is OFF. See figure 2-2. If the indicator light is ON, depress the main power ON/OFF switch, located on the electrical enclosure to turn AC120V operation OFF.

NOTE

The power cord may be removed from the table. The table will operate correctly on battery power with the power cord connected to a wall outlet or disconnected.

b. Press the BATT button on the hand-held pendant control. The red BATTERY indicator light, located in the upper right corner of the pendant control, will illuminate. This confirms that the table is now being operated with battery power.

c. The table is now ready to operate on battery power. Press TABLE UP button on the pendant control to set the table's brakes. An electronic timer will activate the brake system until the brakes are completely set, approximately 8-10 seconds. Press desired function button to position the table.

d. To extend the battery charge life, turn the BATTERY power OFF with the pendant control when the table is not going to be used.

NOTE

Battery Operation must be turned OFF at the pendant control. It can not be turned Off using the main power switch.

3-3. Automatic Shut-Off

a. To prevent unnecessary discharge of the battery, a timer is built into the battery circuit. This timer will automatically shut the battery power OFF after 3-4 hours of table inactivity.

b. To turn the table "ON" again, simply press the BATT button on the pendant control and the red indicator light will illuminate. Select any control button to operate the table.

3-4. Charging the Battery

Batteries should be charged:

- When the table is placed into initial service
- As indicated by red indicator light blinking
- Every week in normal service

NOTE

If the table is stored for a period greater than 6 months, the batteries should be removed and stored in a dry, clean condition at a storage temperature of 68° F (20° C). Batteries should be recharged every 6 months of product storage.

a. If the battery needs to be charged when operating the table on battery power, the red indicator light on the pendant control will begin to blink. At this time the battery needs to be recharged.

NOTE

- When the red light starts to blink (indicating low power in battery) the table will operate for approximately 5 continuous minutes, typically long enough to use the table for the rest of the day.
- The charging system operates ONLY when the table is in AC120V mode.

b. To recharge the battery, connect the power cord to the table and plug the power cord into a 120VAC wall outlet. Turn the main power ON/OFF switch ON by depressing it. The green AC120V light on the pendant control must be ON. The red indicator light will remain ON as well.

NOTE

In battery mode, only the red indicator light will be on. In AC 120V mode, both the green indicator light and red indicator light will be on.

c. A full battery charge will last approximately 2 weeks under normal operating conditions. However, it is recommended to charge the batteries at the end of each week to establish a normal routine protocol. Lead acid batteries last longer if they are not permitted to fully discharge. The table features (2) 12 volt, sealed, lead acid batteries which require no manual maintenance. Lead acid gel batteries, under a proper charging program, feature an approximate normal life of 4 years.

NOTE

The table can be operated on 120VAC power while the battery is being recharged.

3-5. Emergency Back-up Controls

a. The emergency back-up control switches are located under the access door on the service access cover in the table base. See figure 3-3.

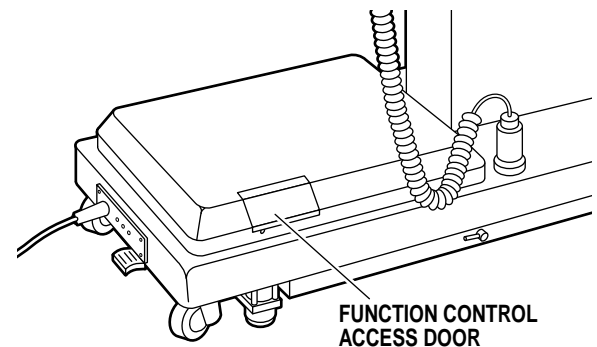

Figure 3-3. Emergency Controls Location

b. In the event of either a power failure or a problem with the hand-held pendant control, the table can be operated using the emergency back-up switches. Simply push the desired emergency switch in the appropriate direction to operate the table functions. See figure 3-4. These switches are spring-loaded so they return to the neutral or center position when released.

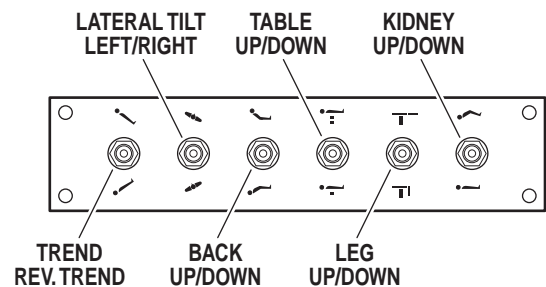

Figure 3-4. Emergency Back-up Controls

NOTE

The emergency back-up control switches will function when the table is operating on 120VAC power, battery power, or turned off.

3-6. Positioning Functions

The hand-held pendant control unit (figure 3-5) activates the following table functions:

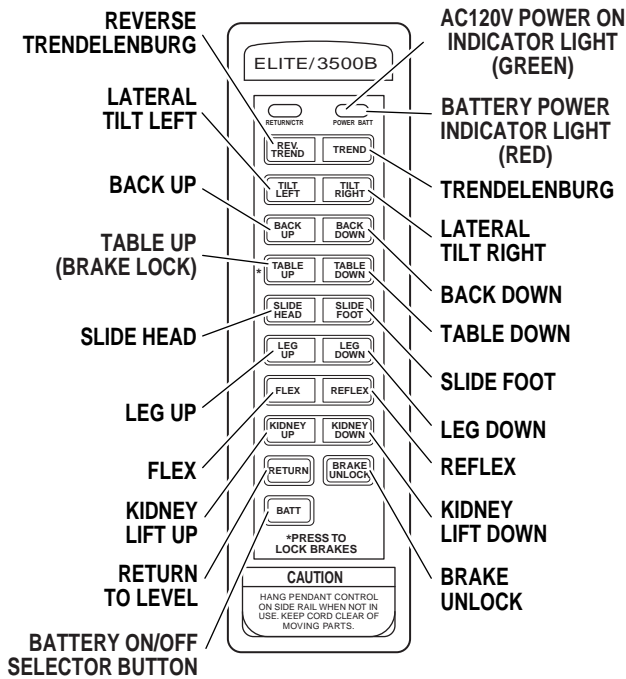

Figure 3-5. Pendant Control Unit

NOTE

With an evenly distributed patient weight load, all table positioning functions will operate smoothly and quietly with a patient weight of up to 500 pounds.

a. Floor Lock/Brake System. To activate the brakes without affecting table positioning, press the TABLE-UP button. See figure 3-6. The elevation cylinder will not function until the brakes are completely extended.

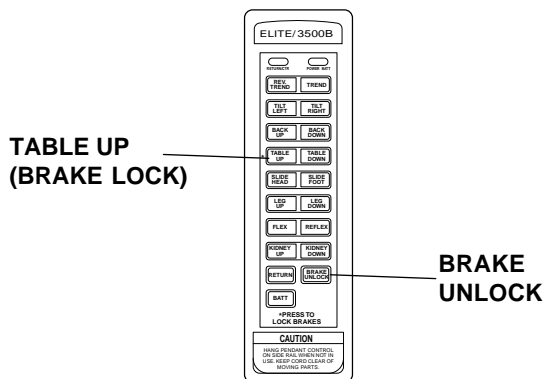

Figure 3-6. Brake System Activation

Press the BRAKE-UNLOCK button on the pendant control to release the four self-leveling brake feet in order to move the table. See figure 3-6. The brake delay circuit automatically retracts the brake system with just one press of the BRAKE-UNLOCK button. It takes approximately 7-8 seconds to totally release the system.



WARNING

DO NOT unlock brakes when a patient is on the table. An uneven patient weight load may cause instability.

b. Trendelenburg. To place the surgical table in a Trendelenburg (head down) position, press the TREND button (figure 3-7). Trendelenburg positioning of up to 25° may be obtained. To place the table in a reverse Trendelenburg (head up) position, press the REV TREND button. Reverse Trendelenburg positioning of up to 20° may be obtained.



WARNING

To maximize patient safety, utilize proper restraint methods during extreme Trendelenburg positioning.

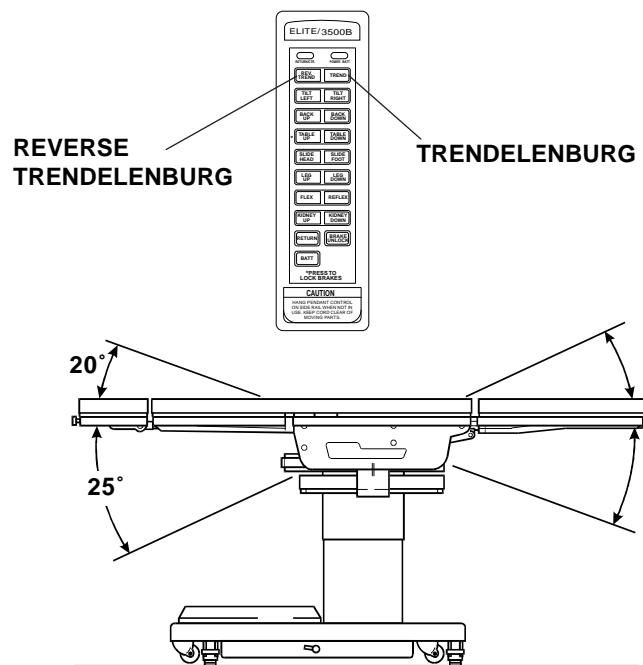

Figure 3-7. Trendelenburg Positioning

c. Lateral Tilt. To achieve lateral tilt right (as viewed from the head end of the table), press the TILT-RIGHT button (figure 3-8). Tilt of up to 20° may be obtained. To achieve lateral tilt left, press the TILT-LEFT button. Tilt of up to 20° may be obtained.

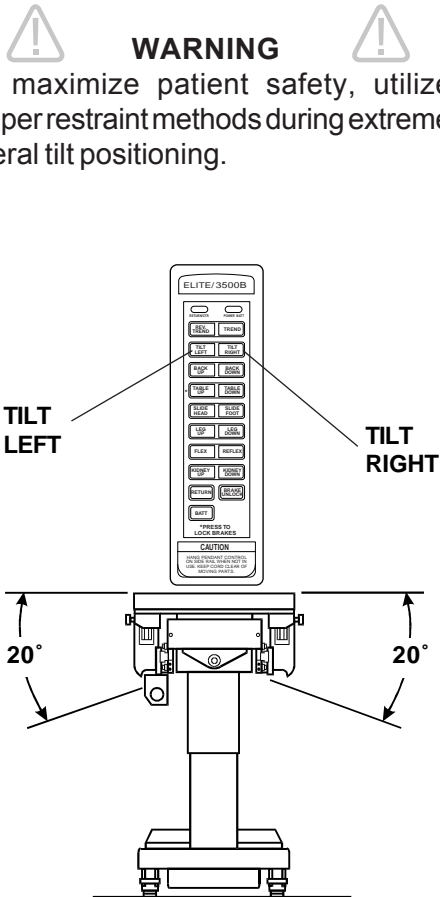

Figure 3-8. Lateral Tilt Positioning

d. Back Section. To raise the back section, press the BACK-UP button (figure 3-9). The back section will raise up to 90° above horizontal. To lower the back section, press the BACK-DOWN button. The back section will go down to 40° below horizontal.

NOTE

If the table top is slid toward the foot end, the back section will not go below horizontal.

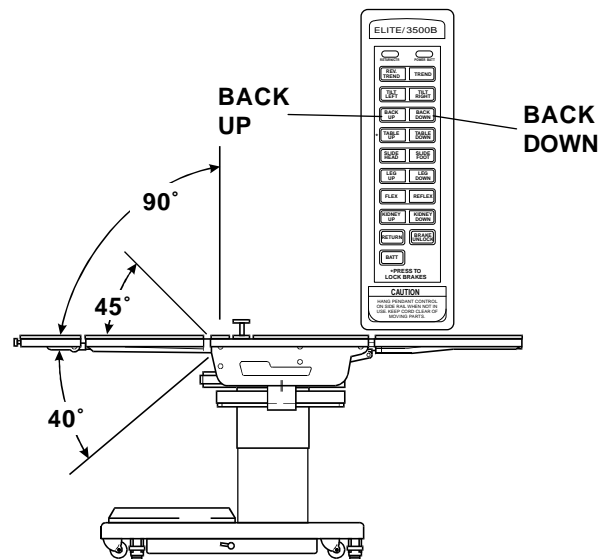

Figure 3-9. Back Section Positioning

NOTE

To prevent damage to the kidney lift, a safety interlock prevents the back section from going up more than 45° if the kidney lift is not all the way down.

e. Elevation. To raise table top, press the TABLE-UP button (figure 3-10.). The table will lift a patient weight of 500 pounds up to a maximum height of 45". To lower the table top, press the TABLE-DOWN button. The table top will go down to a minimum height of 26" (minus pad).

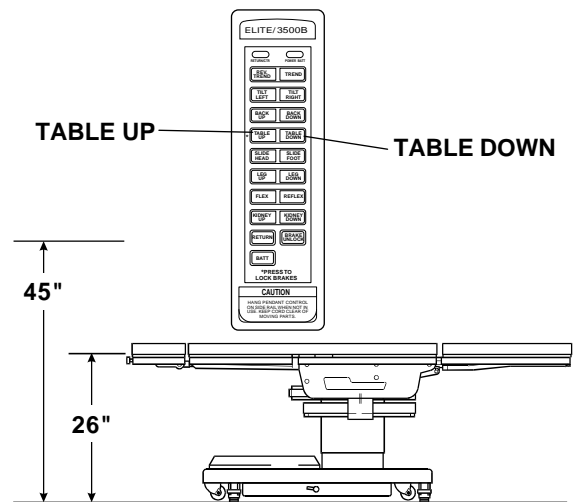

Figure 3-10. Elevation Function

f. Top Slide. To move the table top toward the head end, press the SLIDE HEAD button. From center position, the top will slide up to 7-1/2". See figure 3-11.

NOTE

If the leg section is positioned more than 45° below horizontal, the top will not slide toward the head end.

To move the table top toward the foot end, press the SLIDE FOOT button. From center position, the top will slide up to 13-1/2". Slide function will stop and Slide/Ctr Indicator will illuminate when table is centered.

NOTE

If the back section is positioned below horizontal, the top will not slide toward the foot end.

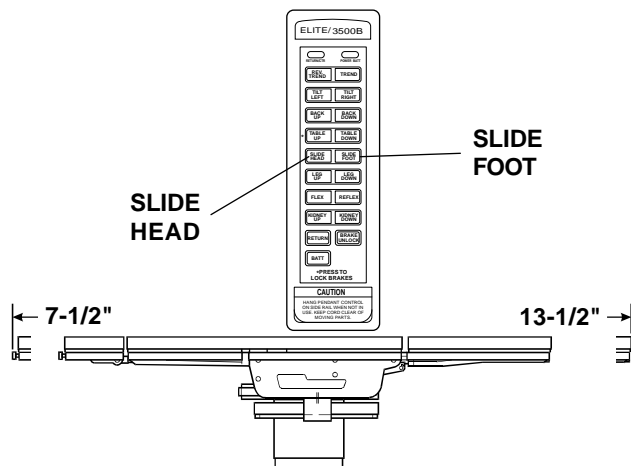

Figure 3-11. Top Slide

g. Leg Section. To lower the leg section, press the LEG-DOWN button (figure 3-12). The leg section will go down to 98° below horizontal. To raise the leg section, press the LEG-UP button. The leg section will go up to 2° above horizontal.

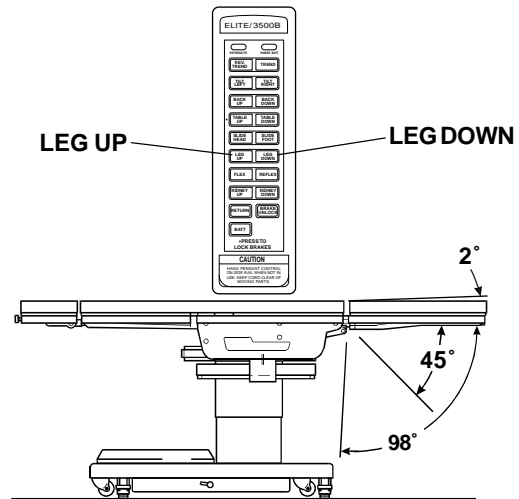

Figure 3-12. Leg Section Positioning



CAUTION



The leg section may hit the table base or floor if both the leg and elevation systems are placed in their full down position.

NOTE

If the top is slid toward the head end, the leg section will only go down 45°.

h. Flex Positioning. To place the table top in a flex position from horizontal, press the FLEX button (figure 3-13). To return the table top to a horizontal position or into a reflex position, press the RETURN or REFLEX button.

NOTE

When FLEX button is activated and if the top is slid toward the foot end, the back section will not go below horizontal.

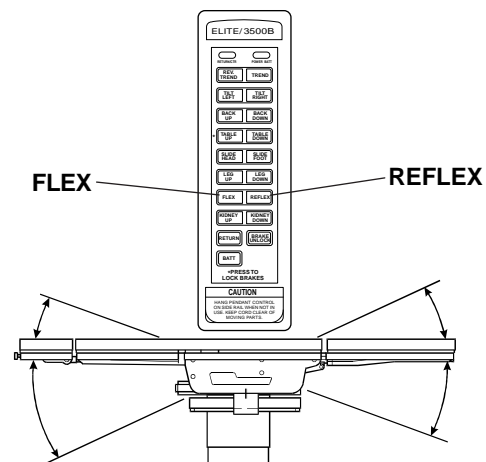

Figure 3-13. Flex/Reflex Positioning

i. **Kidney Lift.** To raise the built-in kidney lift, press the KIDNEY-UP button (figure 3-14). Up to 5-1/2 inches of lift can be achieved. Press the KIDNEY -DOWN button to lower the kidney lift.

NOTE

To prevent damage to the kidney lift, a safety interlock prevents the kidney lift from going up if the back section is 45° above horizontal.

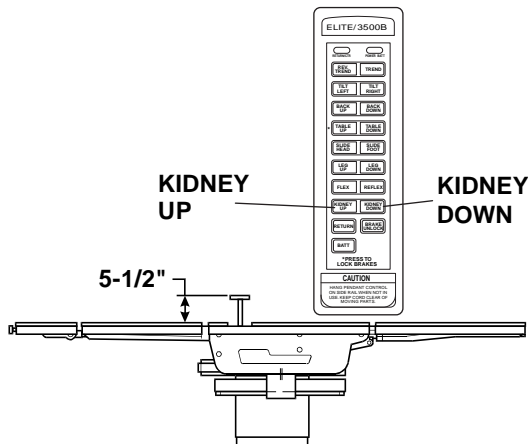

Figure 3-14. Kidney Lift Positioning

j. **Return To Level.** To return the table top to a level position, press the RETURN button (figure 3-15).

NOTE

Elevation, kidney lift, top slide and brake system functions are not affected by the return to level function.

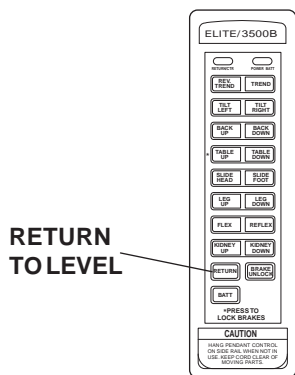

Figure 3-15.

3-7. Emergency Brake Release.

In case of a power failure or an electrical problem within the table, the emergency brake release system can be used to move the table. The control lever for this function is located on the side of the table base and is identified by an EMERGENCY BRAKE RELEASE label. Turn the lever counter-clockwise to release the brakes. See figure 3-16.

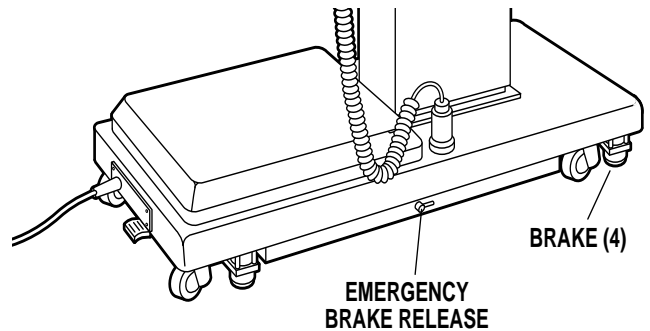

Figure 3-16. Emergency Brake Release



CAUTION



- The Emergency Release Valve must be closed and tightened (clockwise) before activating any hydraulic function.

- If the Emergency Brake Release Valve has been operated, the UNLOCK button on the pendant control will have to be pressed before brakes will lock again.

3-8. Head Section

a. A quick release positioning bar located under and to the front of the head section (figure 3-17) is used to raise or lower the head section. Pull the release bar toward the head end to allow the section to pivot up or down. Positioning from 60° above horizontal to 90° below horizontal in 15° increments is available. Release the bar to lock the head section in position.

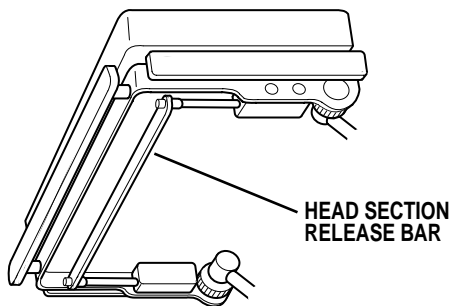

Figure 3-17. Head Section Adjustment

b. By loosening two locking knobs beneath the back section, an additional 5" of longitudinal adjustment can be achieved. If desired, the head section may be removed by loosening the locking knobs and pulling it straight out of the back section. 3500 Series Tables have the capability of attaching the head section to the leg section for use as a foot extension. Two locking knobs are located on the inside of the leg section for securing the head section. See figure 3-18.

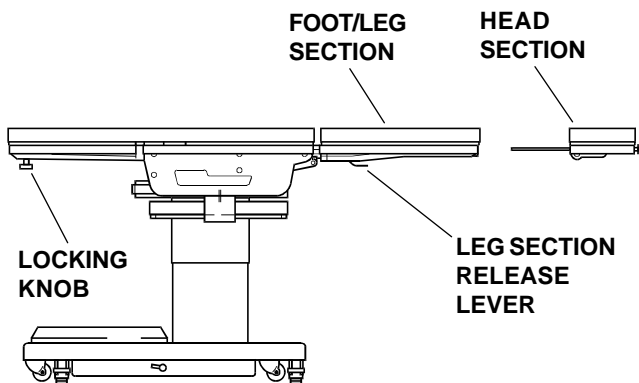

Figure 3-18. Repositioning Head Section



WARNING



In the unlikely event that a procedure requires the reversal of the patient on the table top with the head section attached to the leg section, the patient weight limit is reduced to 300 pounds.

3-9. Leg Section Removal.

NOTE

The leg section with the x-ray top + pad attached weighs 31 lbs. It is recommended that the x-ray top and pad be removed before detaching the leg section.

a. To remove the leg section, position the table top height to elbow height, and simultaneously depress both release levers and pull the leg section out. See figure 3-19. Press the LEG-DOWN button on the pendant control to position the leg section attachment pins down and out of the way.

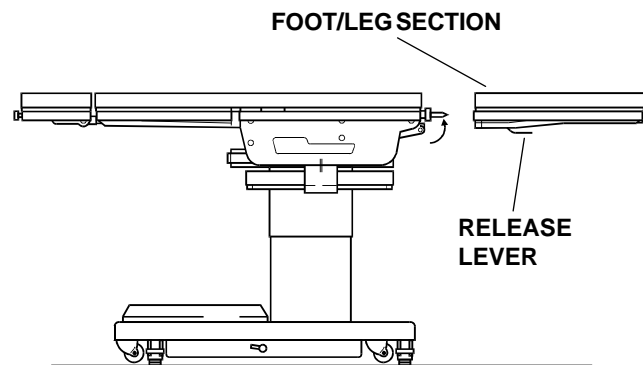

Figure 3-19. Leg Section Release Levers

b. To Install Leg Section, press and hold the LEG-UP button until the leg section attachment pins completely stop before reinstalling the leg section to the table. Pull out on the leg section after installation to make sure the release levers are completely locked.



WARNING



Consult manufacturer's instructions when using high frequency surgical equipment, cardiac defibrillator and cardiac defibrillator monitors.



WARNING



When an antistatic pathway is required, the table has to be used on an antistatic floor.



WARNING



The antistatic properties of the table are dependent on the use of the original pad set which was furnished with the table or an alternate approved replacement.

3-10. Positioning

The use of certain optional accessories available from SKYTRON further extend the positioning capabilities of the 3500 Series Tables. Refer to the following "Positioning Guidelines" or contact your SKYTRON representative for further details.



WARNING



Certain accessories may limit weight capacities. Check with your SKYTRON representative.

3500 Series Patient Positioning Guidelines

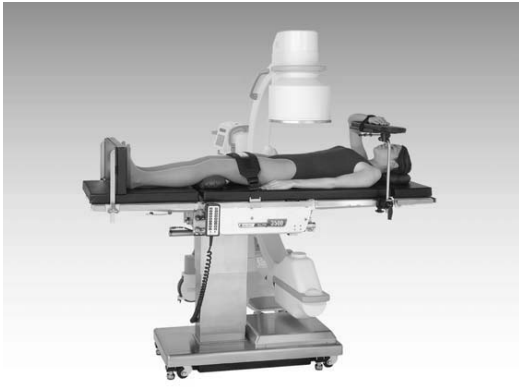

Upper Body Imaging Accessories: 10" Foot Extension and 2" Pad, Snap Strap, Multi-Task Armboard with Pad.

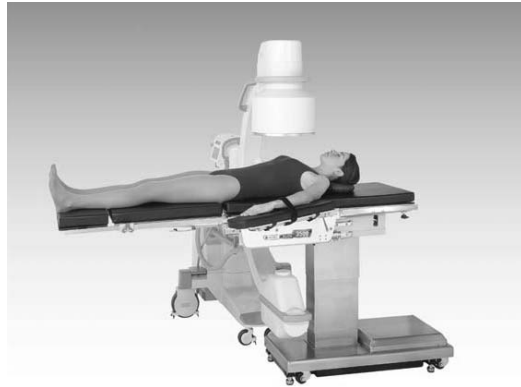

Lower Body Imaging Accessories: 10" Foot Extension and 2" Pad, Standard Armboard and 2" Pad.



Endovascular (with 48" Leg Extension)
Accessories: 48" Carbon Fiber Leg Extension and 2" Pad, Standard Armboard and 2" Pad.



Urology Accessories: Ankl-Lock Stirrups, Uro Catcher, Uro Catcher Pouch, Radiographic Top, Multi-Task Armboard with Pad.

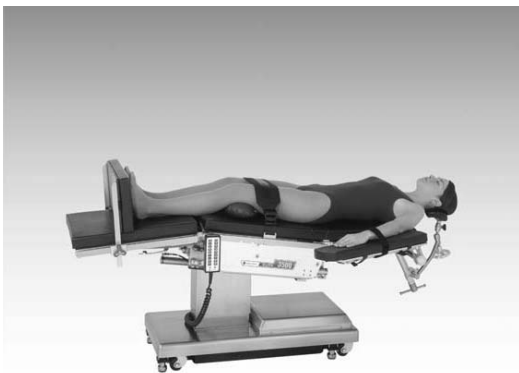

Ophthalmic/ENT Accessories: 10" Foot Extension and 2" Pad, Snap Strap, General Purpose Head Support, Standard Armboard and 2" Pad.

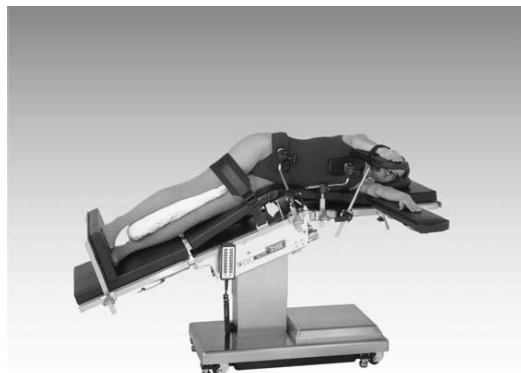

Nephrectomy Accessories: 10" Foot Extension and 2" Pad, Snap Strap, Universal Patient Positioner (pr.), Standard Armboard and 2" Pad, Multi-Task Armboard with Pad.

3500 Series Patient Positioning Guidelines



Neuro (neck) Accessories: 10" Foot Extension and 2" Pad, Snap Strap, Multi-Task Armboard with Pad.

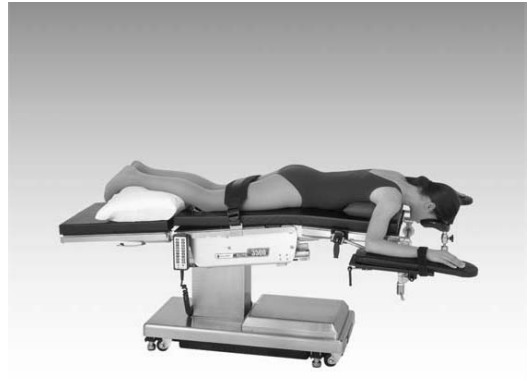

Neuro (lumbar) Accessories: Snap Strap, General Purpose Head Support, Multi-Task Armboard with Pad.



Shoulder Arthroscopy Accessories: 10" Foot Extension and 2" Pad, Lateral Brace, Shoulder Arthroscopy Positioner, Multi-Task Armboard with Pad.



Lumbar Accessories: Knee Rest and 4" Pad, Snap Strap, Multi-Task Armboard with Pad.

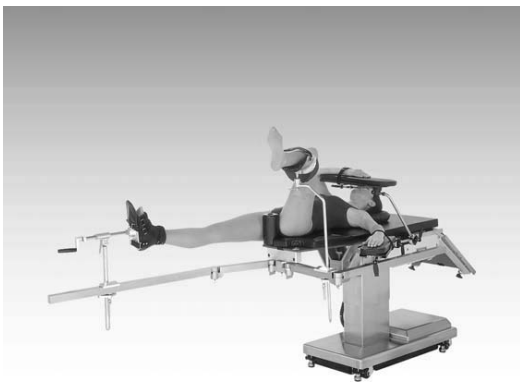

Orthopedic (with Traction Accessories)
Accessories: Orthopedic Extension Package, Multi-Task Armboard with Pad.



Endovascular (with 48" Leg Extension)
Accessories: 48" Carbon Fiber Leg Extension and 2" Pad, Standard Armboard and 2" Pad.

SECTION IV MAINTENANCE

4-1. Preventive Maintenance

The following preventive maintenance checks and services are recommended to ensure the serviceability and proper operation of your SKYTRON Surgical Table.

a. During normal cleaning, a general visual examination should be made checking for leaks, loose bolts or parts and cracked, chipped, or missing paint. Any necessary repairs should be made.

b. Semi-annually the following checks and services should be performed:

1. Check all hydraulic fittings, mini-valves and slave cylinders for proper operation and any signs of leaks.
2. Check the hydraulic speed controls and adjust if necessary.
3. Pressure check (with a gauge) the pressure relief valve.
4. Check all mechanical adjustments and adjust as necessary.
5. Check hydraulic fluid level.
6. Lubricate the elevation slider assembly.
7. Lubricate the top slide components.

4-2. Cleaning Recommendations

NOTE

Always follow current AORN Journal Guidelines to ensure proper cleaning and disinfection procedure.

The following procedures should be followed when cleaning the surgical table between cases.

Place table top in level position prior to starting cleaning procedure.



WARNING



Always follow OSHA blood-borne pathogens standards for protective clothing, including gloves, masks and eye protection when cleaning the surgical table.

Remove major contaminants from the table with disposable materials following appropriate biohazard waste disposal procedures.

Remove all table pads and place them on a flat surface for cleaning.



CAUTION



Thoroughly read and follow the manufacturer's directions for all cleaning fluids. DO NOT use cleaners containing phenolics.

Apply cleaning fluid liberally to top and sides of each pad and wipe with a clean lint-free cloth.

Using a clean, damp, lint-free cloth, wipe the pads to remove the cleaning fluid.

Using a clean, dry, lint-free cloth, wipe the pads to remove all moisture.

Repeat the steps to clean the bottom of the each pad.



CAUTION



When using spray cleaners DO NOT spray fluids directly into electrical receptacles or micro switches.

Repeat cleaning procedure for all table surfaces including the top, sides, elevation column, base and all accessories.



CAUTION



Before replacing pads on the table, make sure the pads and all mating surfaces are completely dry. Moisture trapped between the pads and mating surfaces may cause distortion of table tops.

When the cleaning procedure is complete, replace all pads and accessories as applicable.

Remove pendant control from table side rail and apply cleaning solution to the pendant control and cord.

Use a clean cloth dampened with water to remove cleaning solution.

Use another clean damp cloth to remove any remaining residue.

Install pendant control on side rail for storage when cleaning procedure is complete.

4-3. Service

Table maintenance can be performed by trained maintenance personnel using SKYTRON authorized replacement parts and service techniques. Service instructions and parts are available from SKYTRON.

To obtain service instructions, replacement parts, factory service or preventive maintenance contracts, contact the SKYTRON representative listed below.

Or contact:

SKYTRON

5000 - 36th Street S.E.

Grand Rapids, MI 49512

1-800-SKYTRON (1-800-759-8766)

FAX: (616) 957-5053

