

# Axial Piston Variable Pump A7VK

**RE 94010/03.09** 1/12  
Replaces: 11.08

## Data sheet

Series 10  
Size 12, 28  
Nominal pressure 250 bar  
Peak pressure 315 bar  
Closed circuit



## Contents

Ordering Code / Standard Program	2
Technical Data	3
MA Control	5
Dimensions, Size 12	6
Dimensions, Size 28	8
High-Pressure Relief Valve, Direct Operated	10
Installation Instructions	11
General Instructions	12

## Features

2	– Compact dimensions
3	– Mounting flange, drive shaft and functions identical to A2VK...-SO2 yet with more compact dimensions, thus easy to replace
5	
6	– Increased corrosion protection through special surface treatment of all main components
8	
10	– Manual adjustment with precision display and clamp unit to prevent accidental adjustment
11	
12	– Double shaft sealing made of special material and flushing chamber to identify damage and protect the environment
	– High permissible filling pressure for highly-viscous metered fluid by separating the filling channel and pump case
	– Good volumetric efficiency through robust rotary group using proven axial tapered piston technology

## Note

The axial piston pump is approved for pumping polyurethane components (polyol and isocyanate).

# Ordering Code / Standard Program

<b>A7VK</b>	<b>G</b>		<b>MA</b>	<b>/</b>	<b>10</b>	<b>M</b>		<b>S</b>			<b>5</b>		
01	02	03	04		05	06	07	08	09	10	11	12	13

## Axial piston unit

01	Variable bent axis design, nominal pressure 250 bar, peak pressure 315 bar	<b>A7VK</b>
----	--	-------------

## Operation mode

02	Pump in closed circuit	<b>G</b>
----	------------------------	----------

## Size

03	≈ Displacement $V_{g \max}$ in $\text{cm}^3$	<b>012</b>	<b>028</b>
----	--	------------	------------

## Control device

04	Control, manual with handwheel	<b>MA</b>
----	--------------------------------	-----------

## Series

05	Series 1, index 0	<b>10</b>
----	-------------------	-----------

## Version for service line ports and fixing threads

06	Metric (Europe, ROW)	<b>M</b>
----	----------------------	----------

## Direction of rotation

07	Viewed from drive shaft	clockwise, standard	<b>R</b>
		counter-clockwise, option	<b>L</b>

## Seals

08	FKM (fluor-caoutchouc), PTFE (polytetrafluor ethylene)	<b>S</b>
----	--	----------

## Mounting flange

		<b>012</b>	<b>028</b>		
09	Similar to ISO 3019-2 – 4 bolt	80-4	●	-	<b>K4</b>
		100-4	-	●	<b>L4</b>

## Drive shaft

		<b>012</b>	<b>028</b>		
10	Parallel keyed shaft according to DIN 6885	ø20	●	-	<b>P3</b>
		ø25	-	●	<b>P5</b>

## Service line ports

11	Threaded ports A and B, at side, opposite side	<b>5</b>
----	--	----------

## High-pressure valves

12	Without, standard	<b>0</b>
	With high-pressure relief valve, direct operated	<b>A</b>

## Standard / special version

12	Standard version		<b>-0</b>
		with attachment part	<b>-K</b>
	Special version		<b>-S</b>
		with attachment part	<b>-T</b>

● = Deliverable    - = Not deliverable

## Note

Short description X means a special version that is not covered by the ordering code.

# Technical Data

## Hydraulic fluid

The pump is approved for pumping and metering polyurethane components (polyol and isocyanate). For other hydraulic fluids, consult with Rexroth Service.

## Operating viscosity range

The limiting values for viscosity are as follows:

$v_{\min}$  \_\_\_\_\_ 2 mm<sup>2</sup>/s,

$v_{\max}$  \_\_\_\_\_ 2000 mm<sup>2</sup>/s

Please contact us if higher values are required.

## Operating temperature range

Optimum operating temperature range t \_\_\_\_\_ 10 to 50 °C

Maximum operating temperature  $t_{\max}$  \_\_\_\_\_ 80 °C

The permissible operating temperature is dependent on the lubricity of the respective hydraulic fluid.

The maximum operating temperature must not be exceeded even locally.

## Filtering the fluid

The filter should be arranged so that only filtered fluid enters the pump. The finer the filter, the longer the service life of the axial piston pump.

We recommend a filter grade  $\eta_{\text{abs}}$  \_\_\_\_\_  $\leq 125 \mu\text{m}$

## Operating pressure range

### Pressure at the service line ports A or B (meter in)

Minimum filling pressure \_\_\_\_\_ 1 bar absolute

Maximum filling pressure \_\_\_\_\_ 30 bar absolute

Depending on viscosity and flow, the filling pressure must be adjusted in such a way that a complete filling of the low pressure side of the pump is ensured.

### Pressure at the service line ports A or B (outlet)

Nominal pressure  $p_{\text{nom}}$  \_\_\_\_\_ 250 bar absolute

Peak pressure  $p_{\text{max}}$  \_\_\_\_\_ 315 bar absolute

total operating period \_\_\_\_\_ 50 h

individual operating period \_\_\_\_\_ 10 s

Minimum pressure (high pressure side) \_\_\_\_\_ 10 bar  
for lower pressure, please contact us.

Pressure change speed  $R_A$  \_\_\_\_\_ 9000 bar/s

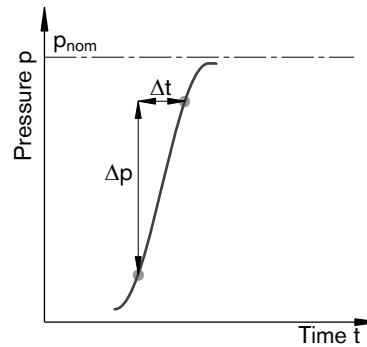

## Definition

### Nominal pressure $p_{\text{nom}}$

The nominal pressure corresponds to the maximum design pressure.

### Peak pressure $p_{\text{max}}$

The peak pressure corresponds to the maximum pressure within the individual operating period. The total of the individual operating periods must not exceed the total operating period.

### Minimum pressure (high pressure side)

Minimum pressure on the high pressure side (A or B) that is required in order to prevent damage to the axial piston unit.

### Pressure change speed $R_A$

Maximum permissible pressure build-up and pressure reduction speed with a pressure change over the entire pressure range.

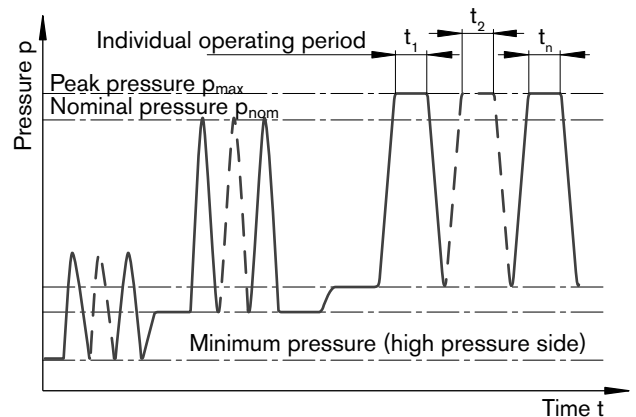

Total operating period =  $t_1 + t_2 + \dots + t_n$

# Technical Data

## Table of values

(theoretical values, without efficiencies and tolerances; values rounded)

Size				12	28
Displacement		$V_{g \max}$	cm <sup>3</sup>	11.6	28.1
		$V_{g \min}$	cm <sup>3</sup>	0	0
Flow at $V_{g \max}$ and at speed n	n = 1500 rpm	$q_{v \max}$	l/min	17.4	42.2
	n = 1800 rpm		l/min	20.9	50.6
Power at $\Delta p = 250$ bar, $V_{g \max}$ and at speed n	n = 1500 rpm	$P_{\max}$	kW	7.3	17.6
	n = 1800 rpm		kW	8.7	21.1
Torque at $\Delta p = 250$ bar and at $V_{g \max}$		$T_{\max}$	Nm	46.2	111.8
Mass (approx.)		m	kg	11.7	22.1

## Case drain fluid

Maximum case drain pressure  $p_{L \max}$  \_\_\_\_\_ 6 bar

The pump ports A and B are separated from the case interior. The case drain fluid must be removed via port T<sub>1</sub> or T<sub>2</sub> using a separate line.

## Shaft seal ring

### Permissible pressure loading

The service life of the shaft seal ring is affected by the speed of the pump, the case drain pressure and the properties of the medium being pumped. It is recommended that the continuous case drain pressure of 6 bar absolute at operating temperature not be exceeded. Short term ( $t < 0.1$  s) pressure spikes of up to 10 bar absolute are permitted. The service life of the shaft seal ring decreases with an increase in the frequency of pressure spikes.

### Note

For monitoring the shaft seal rings for zero leakage, we recommend connecting a barrier fluid monitor at ports U1 to U4.

The minimum case pressure must be equal to or greater than the barrier fluid pressure. In addition, the barrier fluid pressure must be equal to or greater than the external pressure on the outer shaft seal ring.

## Determining the size

$$\text{Flow} \quad q_v = \frac{V_g \cdot n \cdot \eta_v}{1000} \quad [\text{L/min}]$$

$$\text{Torque} \quad T = \frac{V_g \cdot \Delta p}{20 \cdot \pi \cdot \eta_{mh}} \quad [\text{Nm}]$$

$$\text{Power} \quad P = \frac{2 \pi \cdot T \cdot n}{60000} = \frac{q_v \cdot \Delta p}{600 \cdot \eta_t} \quad [\text{kW}]$$

$V_g$  = displacement per revolution in cm<sup>3</sup>

$\Delta p$  = differential pressure in bar

n = speed in rpm

$\eta_v$  = volumetric efficiency

$\eta_{mh}$  = mechanical-hydraulic efficiency

$\eta_t$  = total efficiency ( $\eta_t = \eta_v \cdot \eta_{mh}$ )

## MA Control

Turning the handwheel turns a threaded spindle which steplessly adjusts the pump's rotary group, and thus the flow in the range from  $V_{g \min}$  to  $V_{g \max}$ .

A manual locking device, which is fitted as standard equipment, prevents unintentional adjustment.

The position indicator is integrated in the handwheel.

Size	12	28
Rotation on the handwheel $V_{g \min}$ to $V_{g \max}$ approx. $U_s$	23.4	30
Maximum torque on the handwheel $T_{\max}$ approx. Nm	3.5	3.5

### Circuit diagram counter-clockwise

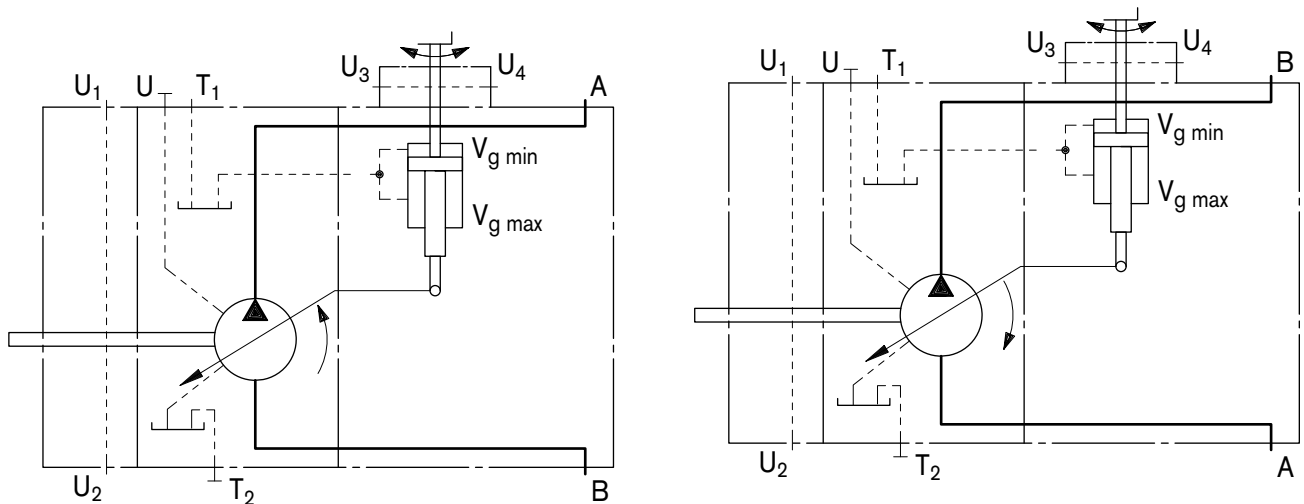

### Flow direction

Direction of rotation, viewed from drive shaft	
clockwise	counter-clockwise
A to B	B to A

### Circuit diagram clockwise

# Dimensions, Size 12

Before finalizing your design, request a binding installation drawing. Dimensions in mm.

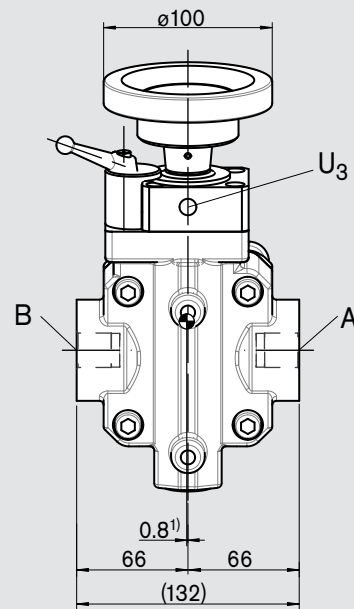
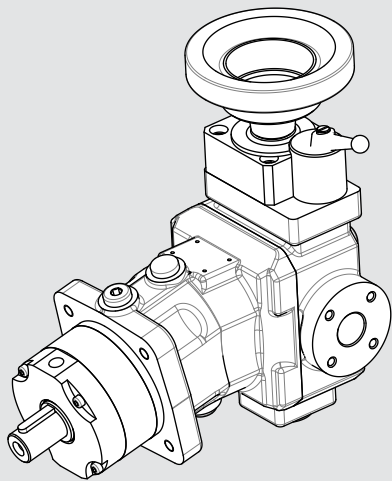
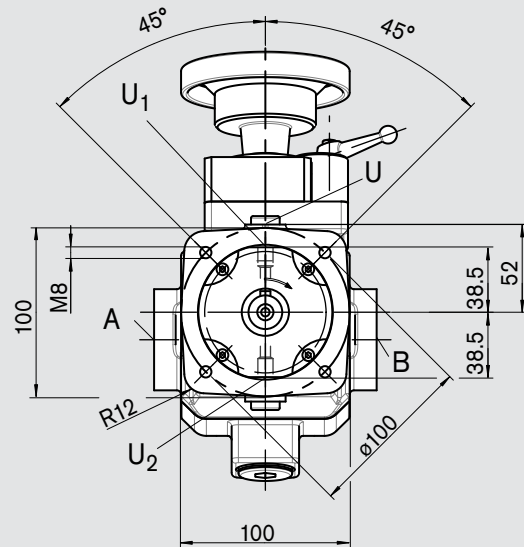
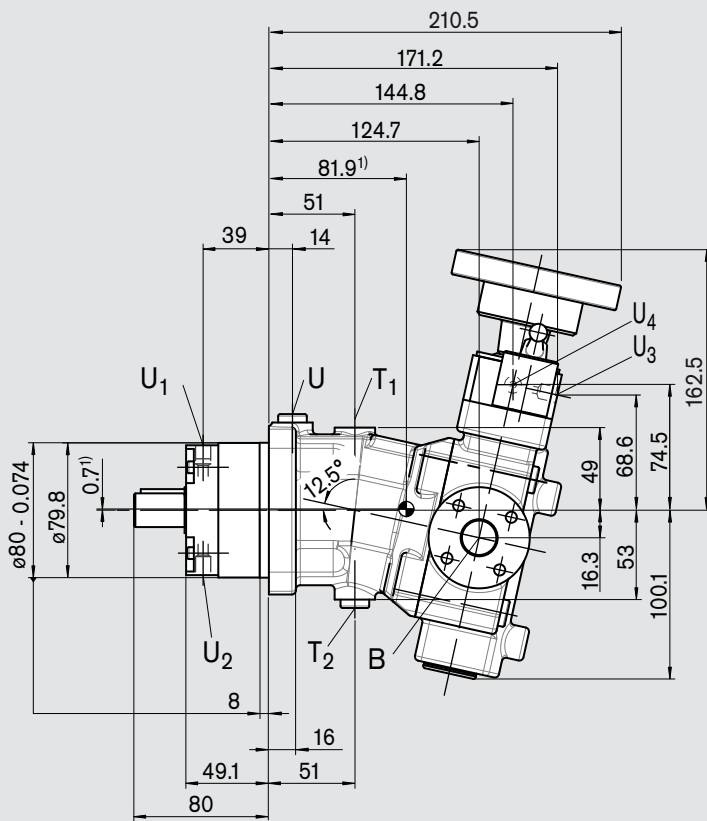

1) Center of gravity

# Dimensions, Size 12

Before finalizing your design, request a binding installation drawing. Dimensions in mm.

## Drive shaft

**P3** Parallel keyed shaft  
DIN 6885 - A 6x6x25.5

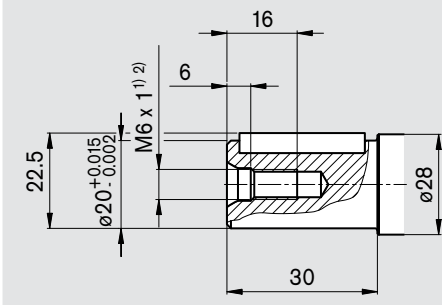

## Ports

Designation	Port for	Standard	Size <sup>2)</sup>	Peak pressure [bar] <sup>3)</sup>	State
A	Service line	DIN 3852	M22 x 1.5; 14 deep	30 <sup>4)</sup>	O
B	Service line	DIN 3852	M22 x 1.5; 14 deep	315 <sup>4)</sup>	O
T <sub>1</sub>	Case drain fluid	DIN 3852	M12 x 1.5; 12 deep	6	O <sup>5)</sup>
T <sub>2</sub>	Case drain fluid	DIN 3852	M12 x 1.5; 12 deep	6	X <sup>5)</sup>
U	Bearing flushing	DIN 3852	M12 x 1.5; 12 deep	6	X
U <sub>1</sub> , U <sub>2</sub>	Barrier fluid	DIN 3852	M10 x 1; 8 deep	3	O
U <sub>3</sub> , U <sub>4</sub>	Barrier fluid	DIN 3852	M10 x 1; 8 deep	3	O

1) Center bore according to DIN 332 (threads according to DIN 13)

2) For maximum tightening torques, the general instructions on page 12 are to be observed

3) Dependent on settings and operating pressure

4) For clockwise only; values for counter-clockwise rotation: A = 315 bar, B = 30 bar

5) Dependent on installation position, T<sub>1</sub> or T<sub>2</sub> must be connected (see also page 10)

O = Must be connected (in the delivered state sealed with plastic plugs)

X = Plugged (in normal operation)

## Dimensions, Size 28

Before finalizing your design, request a binding installation drawing. Dimensions in mm.

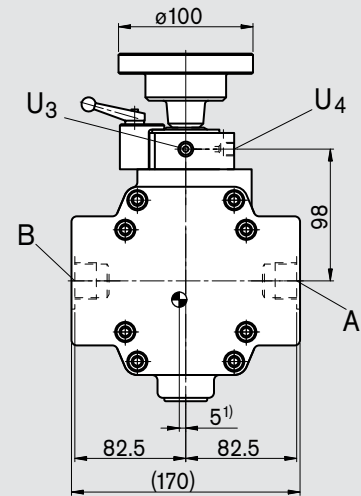
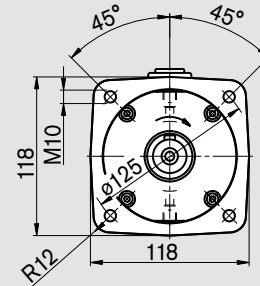
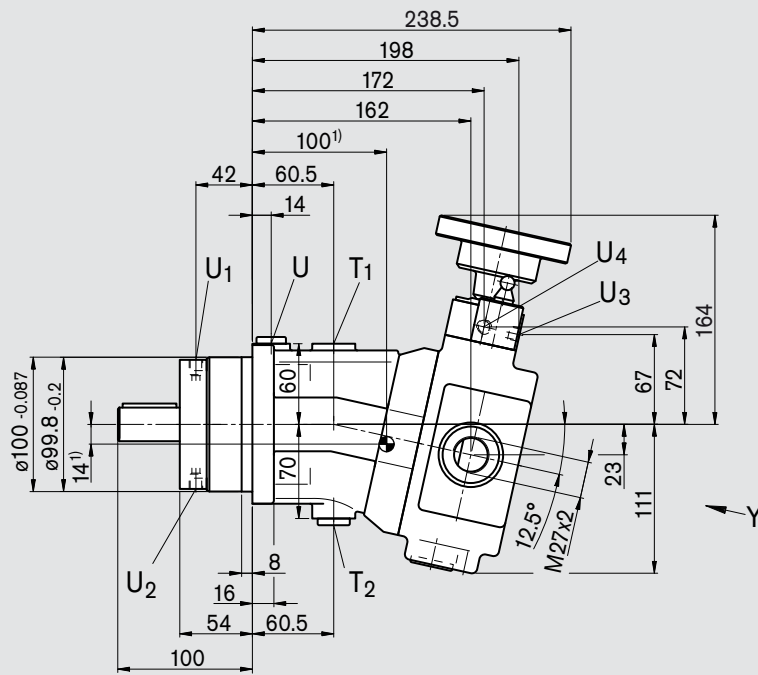

1) Center of gravity



# Dimensions, Size 28

Before finalizing your design, request a binding installation drawing. Dimensions in mm.

## Drive shaft

**P5** Parallel keyed shaft  
DIN 6885 - AS8x7x40

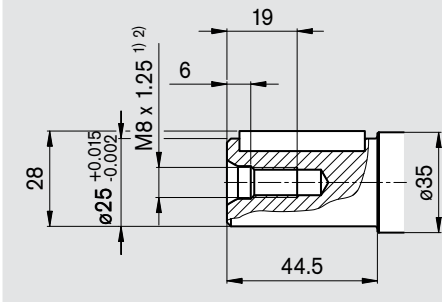

## Ports

Designation	Port for	Standard	Size <sup>2)</sup>	Peak pressure [bar] <sup>3)</sup>	State
A	Service line	DIN 3852	M27 x 2; 16 deep	30 <sup>4)</sup>	O
B	Service line	DIN 3852	M27 x 2; 16 deep	315 <sup>4)</sup>	O
T <sub>1</sub>	Case drain fluid	DIN 3852	M18 x 1.5; 12 deep	6	O <sup>5)</sup>
T <sub>2</sub>	Case drain fluid	DIN 3852	M18 x 1.5; 12 deep	6	X <sup>5)</sup>
U	Bearing flushing	DIN 3852	M16 x 1.5; 12 deep	6	X
U <sub>1</sub> , U <sub>2</sub>	Barrier fluid	DIN 3852	M10 x 1; 8 deep	3	O
U <sub>3</sub> , U <sub>4</sub>	Barrier fluid	DIN 3852	M10 x 1; 8 deep	3	O

1) Center bore according to DIN 332 (threads according to DIN 13)

2) For maximum tightening torques, the general instructions on page 12 are to be observed

3) Dependent on settings and operating pressure

4) For clockwise only; values for counter-clockwise rotation: A = 315 bar, B = 30 bar

5) Dependent on installation position, T<sub>1</sub> or T<sub>2</sub> must be connected (see also page 10)

O = Must be connected (in the delivered state sealed with plastic plugs)

X = Plugged (in normal operation)

# High-Pressure Relief Valve, Direct Operated

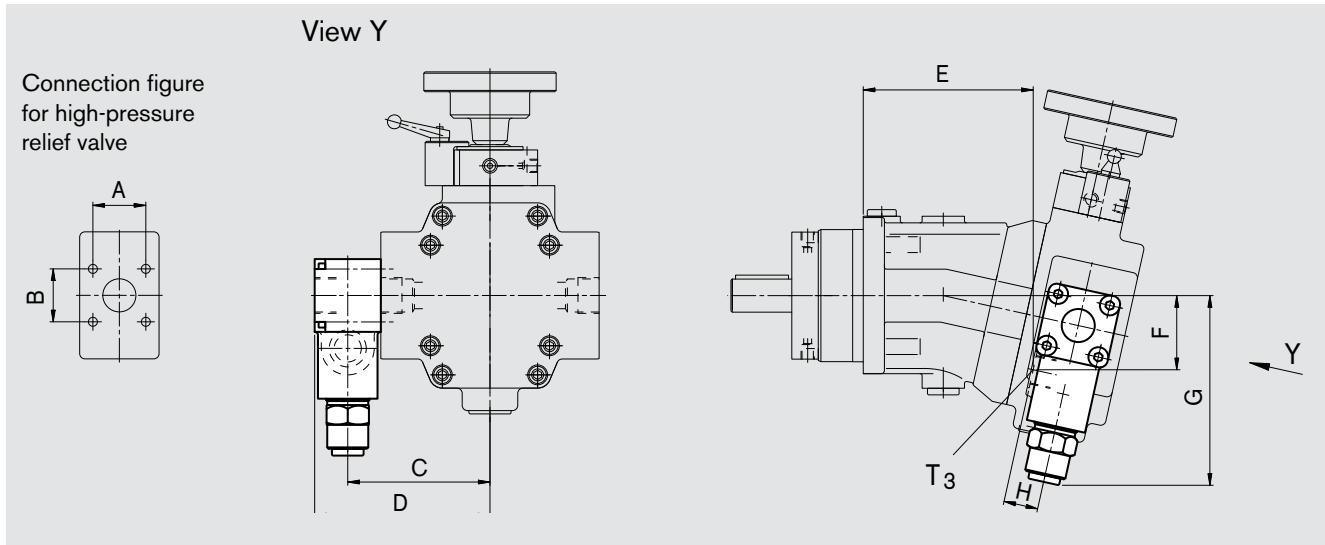

Size	A <sup>2)</sup>	B <sup>2)</sup>	C	D	E	F	G	H	Service ports A, B <sup>1)</sup>	Return port T <sub>3</sub> <sup>1)</sup>
12	32	32	89	112	93.5	42	131	25	M22 x 1.5	M18 x 1.5
28	40	40	108	132.5	128	56	143	26	M27 x 2	M22 x 1.5

1) DIN 3852, for maximum tightening torques, the general instructions on page 12 are to be observed.

2) Fixing threads according to DIN 13; for maximum tightening torques, the general instructions on page 12 are to be observed.

Adjustment range \_\_\_\_\_ 100 to 315 bar

Standard adjustment \_\_\_\_\_ 250 bar

If not specified when ordering, the valves are set to 250 bar.

# Installation Instructions

## General

During commissioning and operation, the axial piston unit must be filled with hydraulic fluid and air bled. This is also to be observed following a relatively long standstill as the system may empty via the hydraulic lines.

The case drain fluid in the case interior must be directed to the tank via the highest case drain port. An air pocket inside the unit will damage the pump and may cause consequential damage.

In all operational states, the case drain line must flow into the tank below the minimum fluid level.

## Installation position

See examples below. Additional installation positions are available upon request.

### Below-tank installation (standard)

Pump under minimum fluid level of the tank.

### Above-tank installation

Pump above minimum fluid level of the tank.

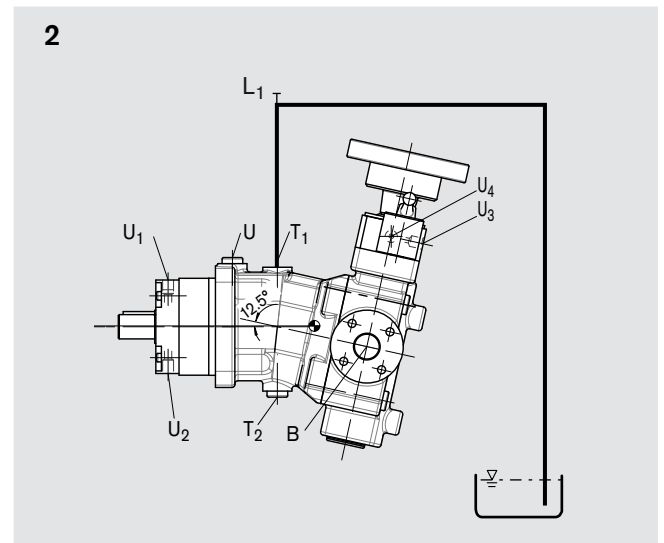
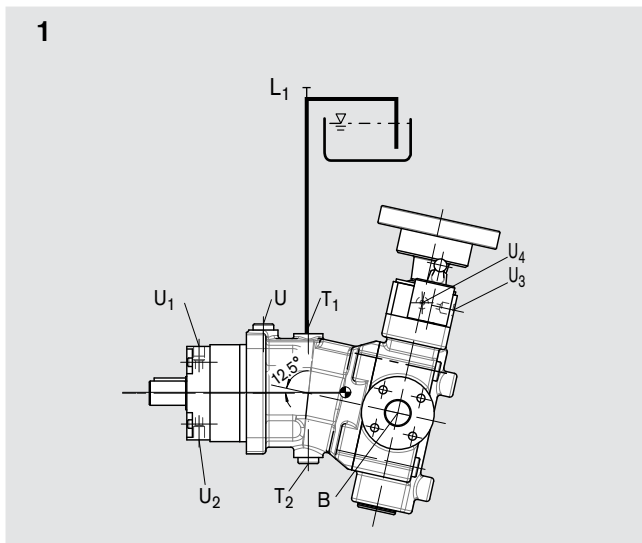

Installation position	Air bleeding	Filling
1	L <sub>1</sub>	T <sub>1</sub> (L <sub>1</sub> )

Installation position	Air bleeding	Filling
2	L <sub>1</sub>	T <sub>1</sub> (L <sub>1</sub> )

# General Instructions

- The A7VK pump is designed to be used in closed circuits.
- The project planning, assembly and commissioning of the axial piston unit require the involvement of qualified personnel.
- The service ports and function ports are only designed to accommodate hydraulic lines.
- During and shortly after operation, there is a risk of burns on the axial piston unit. Take suitable safety measures (e.g. wear protective clothing).
- Pressure ports:  
The ports and fixing threads are designed for the specified peak pressure. The machine or system manufacturer must ensure that the connecting elements and lines correspond to the specified operating conditions (pressure, flow, hydraulic fluid, temperature) with the necessary safety factors.
- The data and notes contained herein must be adhered to.
- The product is not approved as a component for the safety concept of a general machine according to DIN EN 13849.
- The following tightening torques apply:
  - Threaded hole of the axial piston unit:  
The maximum permissible tightening torque  $M_{G \max}$  are maximum values of the threaded holes and must not be exceeded. Refer to the following table for values.
  - Armatures:  
Observe the manufacturer's instructions regarding tightening torques of the armatures used.
  - Fixing screws:  
For fixing screws according to DIN 13, we recommend checking the tightening torque in individual cases as per VDI 2230.
  - Locking screws:  
For the metallic locking screws supplied with the axial piston unit, the required tightening torques of locking screws  $M_V$  apply. Refer to the following table for values.

Threaded port sizes		Maximum permissible tightening torque of the threaded holes $M_{G \max}$	Required tightening torque of the locking screws $M_V$	WAF hexagon socket of the locking screws
M10 x 1	DIN 3852	30 Nm	12 Nm	5 mm
M12 x 1.5	DIN 3852	50 Nm	25 Nm	6 mm
M16 x 1.5	DIN 3852	100 Nm	50 Nm	8 mm
M18 x 1.5	DIN 3852	140 Nm	60 Nm	8 mm
M22 x 1.5	DIN 3852	210 Nm	80 Nm	10 mm
M27 x 2	DIN 3852	330 Nm	135 Nm	12 mm