



---

**Contact Info:**

**Phone:** 855-629-5484

**Email:** [Customerservice@SprintRBattery.com](mailto:Customerservice@SprintRBattery.com)

**Fax :** 440-548-2235

# **12V Battery**

# **Installation Guide**

## Charging Parameters

### **Bulk/Absorption**

For your Bulk/Absorption stage, the ideal voltage is between 14.2V-14.4V. For full charge and balance, the absorption mode should be set to last for at least 20 minutes per battery (for multiple batteries in parallel).

### **Float**

LiFePO4 batteries do not need a float stage for charging, but a float voltage between 13.5V and 13.8V can be used when connected to shore power.

### **Equalization**

Equalization is not recommended for our batteries. Most chargers will allow you to shut this feature off or use a setting that does not use equalization. If you cannot turn off this mode, then you will need to adjust the equalization voltage to below 14.6V and hours.

### **Temperature Compensation**

Temperature compensation is not needed with our batteries and in some cases, may trigger the built-in BMS to go into protect mode. For this reason, we recommend that temperature compensation be shut off or set to 0.

### **Low Battery Disconnect/Shut down**

If an individual cell falls below 2.2V/8.8V during discharge, the battery will shut off the output current. At this time there will be only 1 or 2V present at the terminals. When this happens a standard lead acid battery charger will not be able to recognize the battery and will not start the charging process. For this reason we highly recommend using approved LiFePO4 lithium battery charger.



---

## BMS Basic Features

All SprintR Batteries come with a built-in battery management system (BMS) that protects the cells for long-term cycling. The BMS protects against the following conditions:

**High voltage: > 15.0V or 3.75V per cell**

If an individual cell voltage exceeds 3.75V during charging, the BMS will prevent a charge current from continuing. Discharge is always allowed under this condition.

**Low voltage: < 8.8V**

If an individual cell falls below 2.2V during discharge, the BMS will prevent further discharge. Although the battery is in “low-voltage disconnect” mode, it will still allow a charging current.

**High temperature: > 150°F**

The BMS will not allow a charging or discharging current.

**Low temperature: <32°F**

The BMS will not allow a charging current.

**High Current**

The BMS allows constant current 100 (+/- 5%) Amps, 500 (+/- 10%) Amps for 1s.

A passive balancing process is activated by the BMS at the top of each charge cycle, when the battery voltage exceeds around 14V. This ensures that all the cells remain at the same state of charge, which helps for pack longevity and performance.

## Installation

The batteries may be hooked in any orientation. But care must be taken in connecting to the battery terminals. The positive and negative terminals are labeled and color coded (red for +, black for -).

**DO NOT REVERSE POLARITY THE BATTERY AS THIS WILL DAMAGE BOTH THE BATTERY AND THE DEVICE BEING CONNECTED!!!**

The batteries come with a standard flag style terminal post with a 3/8" hole to accommodate a M8 bolt and lug sizes up to 2 AWT. All batteries ship with 18-8 stainless steel M8 bolts, washers. If multiple lugs are used, the washers may be removed, or longer bolts may be required in order for the bolt to fully seat into the copper pillar.



### Parallel

Max. 4 units are supported for parallel connections, but do please make sure the load power doesn't reach the limited power, like one 12V 100ah is for 1200W, it's better lower than 2400W for 2 in parallel, to avoid the peak current of one battery pack is over 260A, due to the out-sync caused by the length difference of cables.

However, all cables and connections **MUST** be able to accommodate the high currents that can be delivered by the battery. Appropriate fuses and circuit breakers are also highly recommended to protect downstream components from current spikes and short circuits.

---

**Note: The voltage of each battery for parallel connection should be same before connecting and operation.**

**Parallel & Current Specs =**

- 1 - Battery = 100A Max. Charge - Discharge**
- 2 - Batteries = 150A Max. Charge - Discharge**
- 3 - Batteries = 200A Max. Charge - Discharge**
- 4 - Batteries = 250A Max. Charge - Discharge**



### **Series**

Up to four 12100 batteries may be connected in series to increase the voltage of the system up to a 48V system. When batteries are hooked in series, current capacities remain the same, but the system voltage is additive. Two 12100 batteries hooked in series to form a nominally 25.6V system should be charged using a bulk and absorption voltage of 28.8V. Four 12100 batteries hooked in series to form a nominally 51.2V system should be charged using a bulk and absorption voltage of 58.4V. Batteries to be connected in series should be at the same state-of-charge before they are connected. For best results, fully charge each 12v battery using a 12V charger prior to connecting them in series, in order to ensure that they are at the same state-of charge



## Series and Parallel

12100 could be connected max.4 in series and parallel in theory, to reach 48V 400ah. But we don't

suggest to work like this, it's very hard to keep all the cables and connections in ideal condition.

Therefore, max. 2S4P is suggested, batteries to be connected in series should be at the same state-of-charge before they are connected. For best results, fully charge each 12V battery using a 12V charger

prior to connecting them in series, in order to ensure that they are at the same state-of-charge. The

connecting diagram for 4S2P and 2S4P are showing below,

**2S-4P**  
24V 400Ah Set up

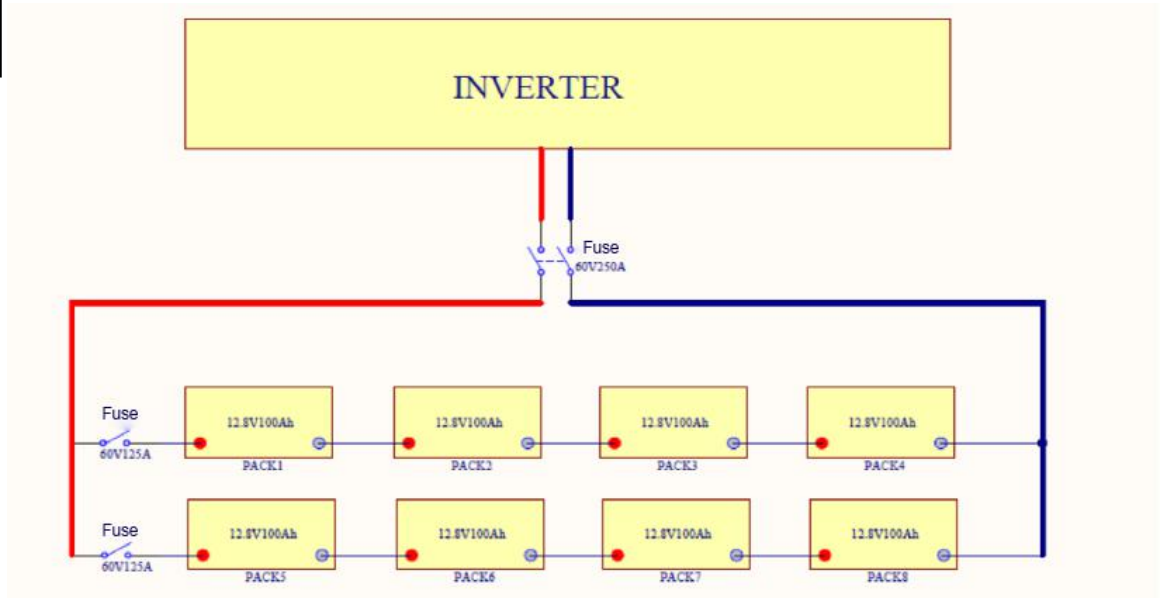

**4S-2P**  
48V 200Ah Set up

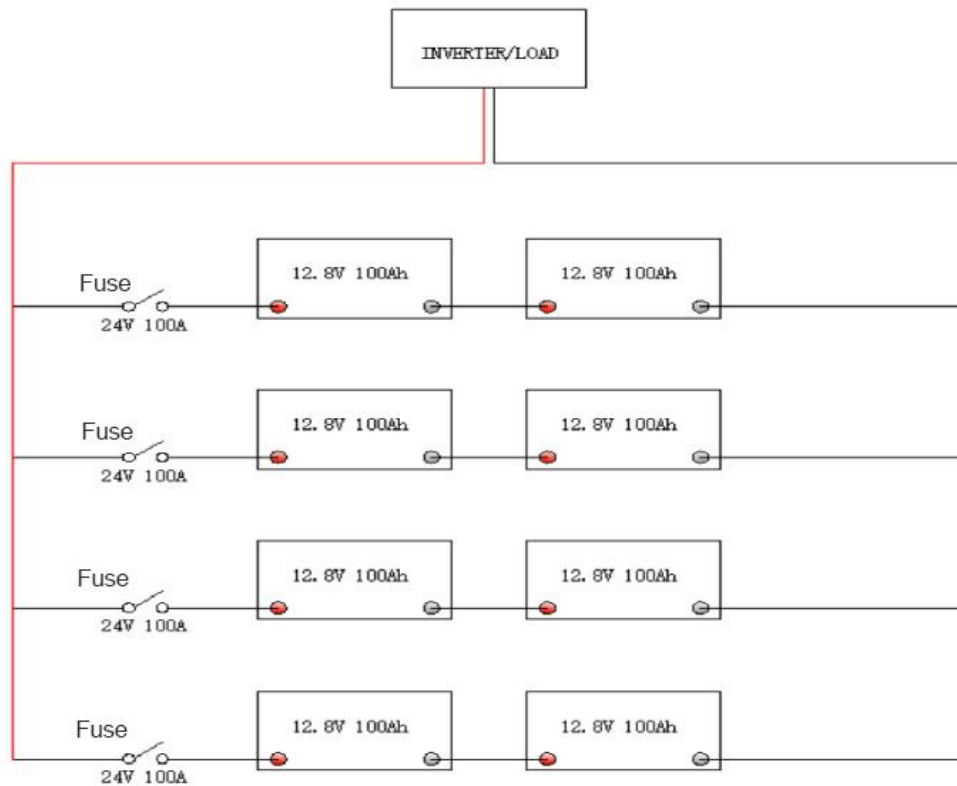

## Charge/Discharge Curve & Cycle life

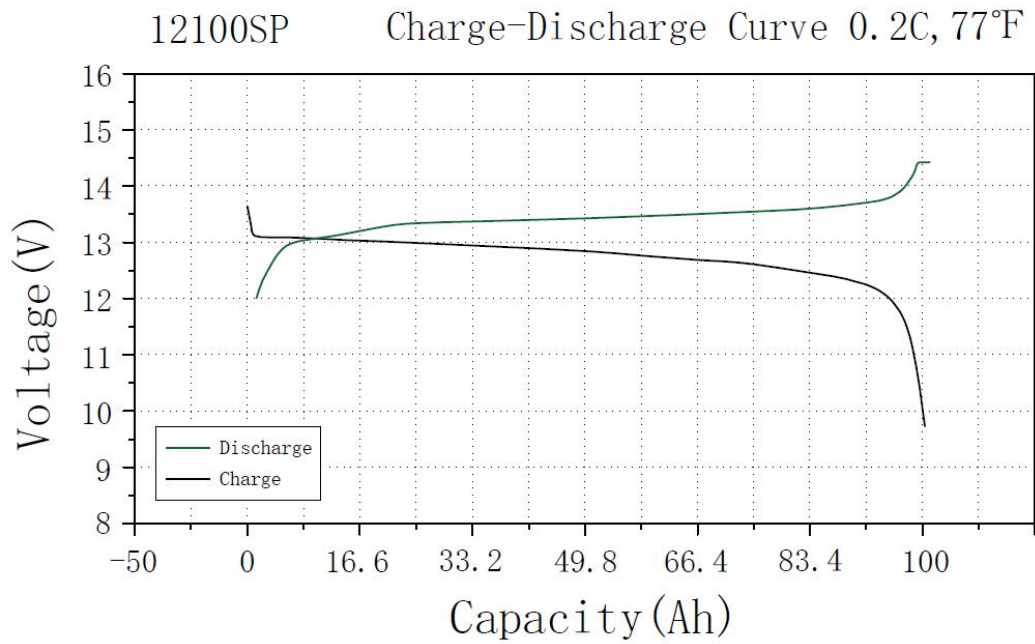

### 80% Remaining Capacity after these Cycles

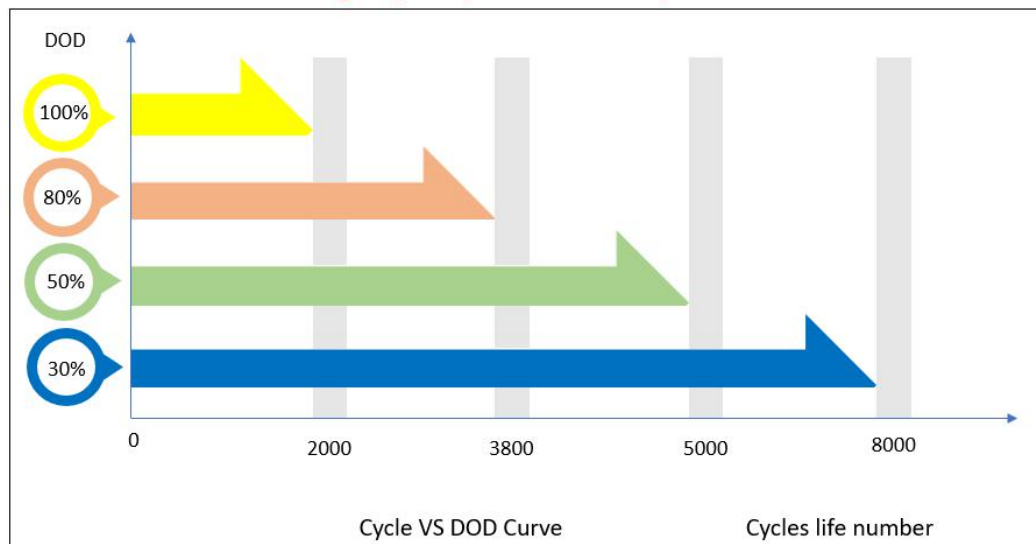



## **SprintR Cautions:**

When connecting your lithium battery for charging or discharging, always tighten connector bolts with torque wrench set to the specified torque setting, not by hand. If the connection is not good and stable, the terminals could become very hot and cause internal damage to battery.

- Do not charge battery with an alternator or other unapproved chargers!
- Do not cross-circuit battery
- Do not immerse battery in water.
- This battery is water-resistant. Do not use in direct rain or other wet conditions.
- Never charge or discharge battery with more than its rated Amps.
- Built-in low temp charging protection. Do not charge if under 32°F
- Always use ring terminals if charging or discharging with more than 5 Amps
- The SprintR fuel guage is only accurate if battery is in standby mode.
- Failure to follow the above instructions could be dangerous and can void the warranty
- In case of deformation or leakage of the battery, immediately place outside and away from buildings, and contact a SprintR sales representative

## **Storage and maintenance**

### **Storage**

Storage could not be easier simply charge the batteries to at least 50%/13.3V state-of-charge and disconnect from any charge or discharge and repeat this step every quarter/3 months

### **Maintenance**

The LiFePo4 batteries require very little maintenance if any at all. If your batteries are in series and not being charged by a multi-bank charger, it is recommended that you fully charge the batteries individually once a year. This will balance out the entire battery bank to ensure the batteries will reach its expected life span. If your batteries are in parallel this is not necessary. The BMS has a built in passive balancing system that will take care of this.

## Warranty Policy and Quality Statement

### Warranty



#### **ULTIMATE 3 YEAR WARRANTY:**

Things do go wrong. If you ever have a warranty claim we will address your needs as quickly and fairly as possible. We at Millertech are passionate about the products we design and build, and are committed to backing them up! We believe a warranty, may it be 1yr or 10yrs is only as good as the company standing behind it, along with the people that care about your satisfaction! Millertech warrants each SprintR branded battery sold by Millertech or any of its authorized dealers or distributors worldwide, to be free of defects for a period of 3 years from the date of sales. Within the warranty time frame, subject to the issues listed below, manufacturer will repair or replace the battery and/or parts of the battery if the components in question are defective in materials or workmanship.

#### **NOT COVERED BY THIS WARRANTY:**

Manufacturer is not obligated to warrant the SprintR battery in question if defects are related to damages caused by abuse/neglect, or from the following:

- Damage from shipping, loose terminal bolts or corroded hardware.
- Manufacturer codes tampering or removal
- Failure to properly install the battery, in addition to keeping the battery properly charged or maintained
- Breakage from collision, fire or freezing which includes damage from extreme heat or cold, improper storage, water damage or tampering

The Warranty does not cover a battery reaching its normal end of life which may occur prior to warranty periods stated above. Depending on the application, a battery can reach its normal end life before the end of Applicable Warranty Period. A battery can deliver only a fixed number of usable amp hours over its lifetime and is considered to have reached its normal end of life if the application used up all of these amp hours, regardless of the time the battery has been in service. Therefore Manufacturer reserves the rights to deny a warranty claim if it determines the battery to be at its normal end of life even if the claim is lodged within the Applicable Warranty Period. Please see the graph below to find out what set points to use in order to reach your desired cycle life!



**FOR WARRANTY SERVICE CALL:855-MAX-LITH(855-629-5484) OR EMAIL [CUSTOMERSERVICE@SPINTRBATTERY.COM](mailto:CUSTOMERSERVICE@SPINTRBATTERY.COM)**

If it is determined that your battery requires further inspection, arrangements will be made to ship it to the SprintR manufacturer site. Proof of purchase is required and should include the original invoice and serial number.

Recommended Operating Conditions for 3 Year Warranty									
Equivalent to 80% Retained Capacity	3800 Cycles			2800 Cycles			2000 Cycles		
Discharge/Charge Rate <sup>1,2</sup>	C/2 = 20% of AH								
DoD <sup>4</sup>	80%			90%			100%		
Operating Temperature °F	32 to 110			32 to 120			32 to 120		
Programming Setting for Ancillary Equipment	12V	24V	48V	12V	24V	48V	12V	24V	48V
Absorb / High Cut-Off Voltage (V) <sup>3</sup>	14	28	56	14.2	28.4	56.8	14.4	28.8	57.6
Recharge / Low Cut-Off Voltage (V) <sup>3</sup>	12.8	25.6	51.2	12.5	25	50	12	24	48

## QUALITY STATEMENT

Proper use and maintenance will ensure that the battery (or battery system) will operate reliably and consistently for long periods of time.

- After receiving the product, please contact with our after-sales or sales staff within five working days
- Anyone who does not use or maintain the battery according to the manual shall be deemed to give up the warranty right. Suppliers and its service station have the right to no longer guarantee the warranty, and will not compensate for any losses arising from it. However, the corresponding paid service can be provided according to the situation.