

# 간단 설치 안내서

PM32F·PM43F·PM49F·PM55F

PH43F·PH49F·PH55F



## 구성품

- ☑ 누락된 품목이 있으면 구매한 판매점에 문의하세요.
- ☑ 구성품의 그림은 실물과 다를 수 있습니다.
- ☑ 스탠드는 기본으로 제공하지 않습니다. 별도로 구매하여 설치하세요.

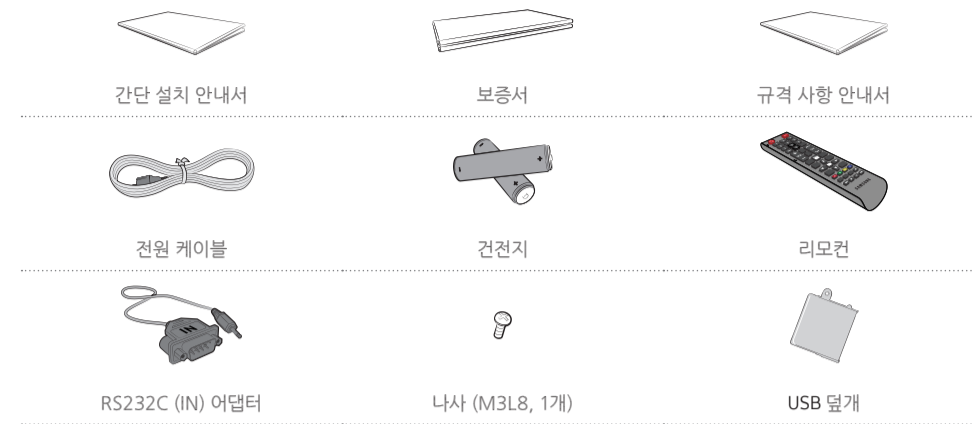

- 자세한 내용은 웹사이트(www.samsung.com/displaysolutions)에서 사용자 설명서를 다운로드하여 참고하세요.
- 설명서에는 NAVER에서 제공한 나눔고딕에코 글꼴이 적용되어 있습니다. 링크를 클릭할 수 있는 친환경 글꼴입니다.

**HDMI** The terms HDMI and HDMI High-Definition Multimedia Interface, and the HDMI Logo are trademarks or registered trademarks of HDMI Licensing LLC in the United States and other countries.



## 외부기기 연결 및 사용하기

### PC와 연결하기

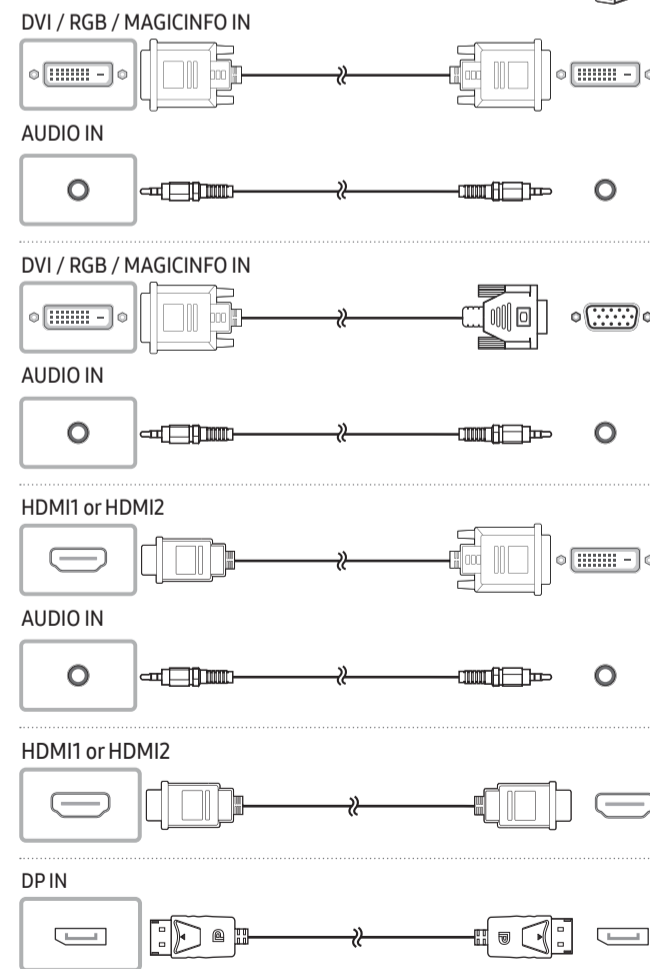

### 다른 모니터 연결하기

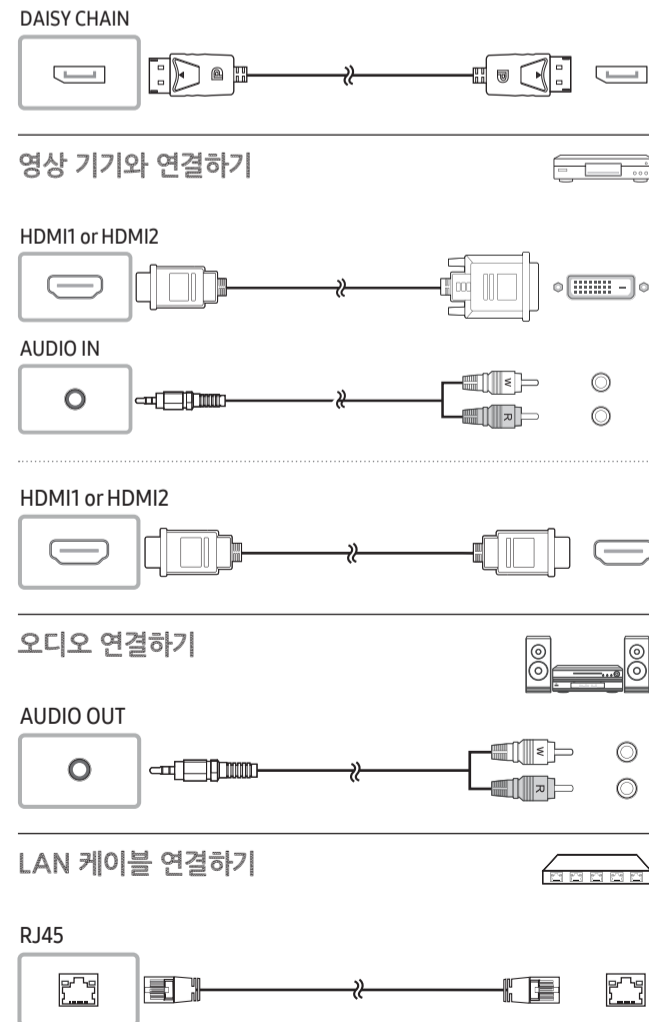

### MDC 연결하기

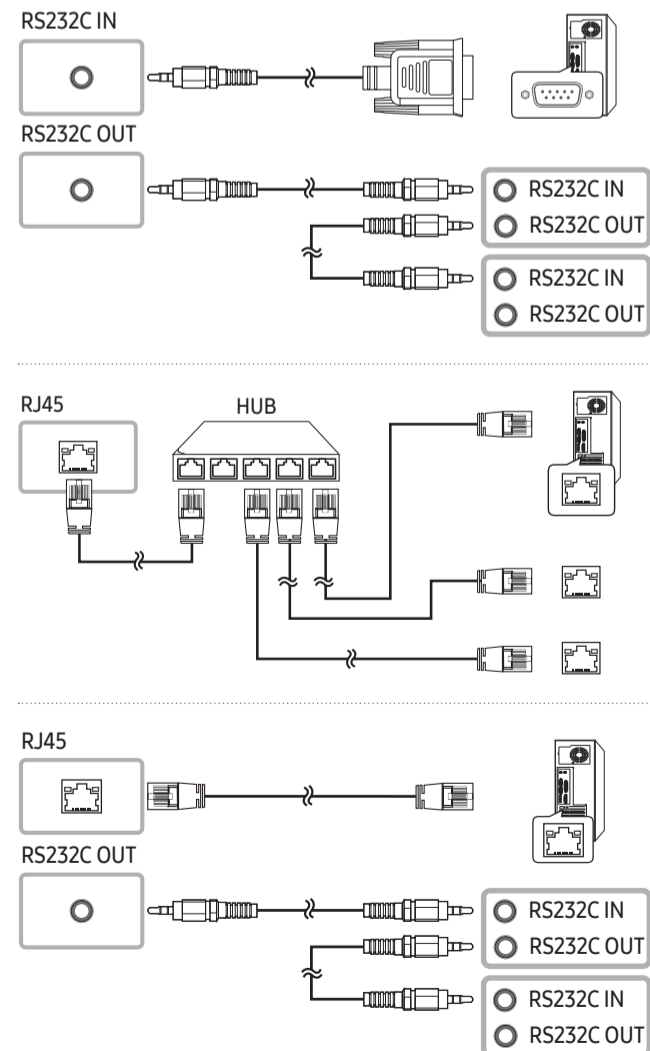

## 뒷면 설명

- ☑ 제품에 따라 색상 및 형상이 다를 수 있으며 규격내용은 성능개선을 위해 예고 없이 변경될 수 있습니다.

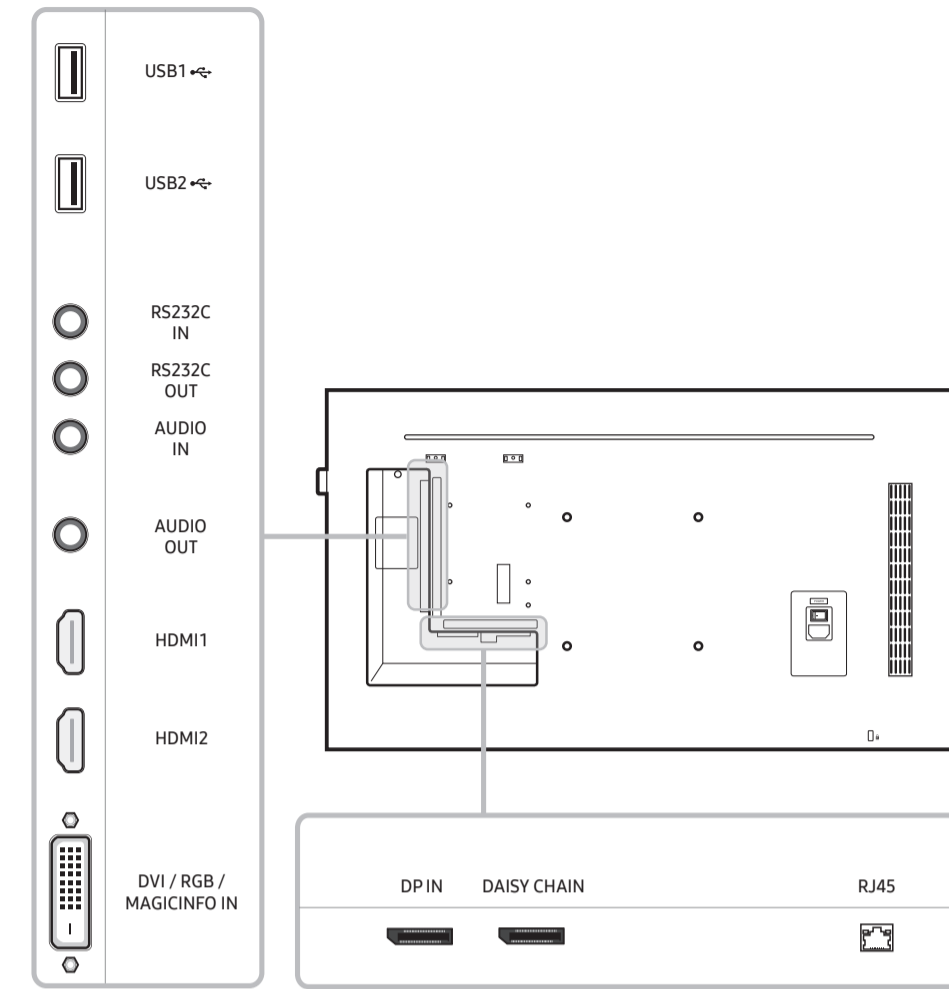

단자	설명
USB1	USB 장치를 연결할 때 사용합니다.
USB2	
RS232C IN	RS232C 어댑터를 이용하여 MDC를 연결할 때 사용합니다.
RS232C OUT	
AUDIO IN	음향 케이블을 이용하여 소리를 입력할 때 사용합니다.
AUDIO OUT	헤드폰이나 외부스피커로 소리를 내보낼 때 사용합니다.
HDMI1	HDMI 케이블을 이용하여 외부기기를 연결할 때 사용합니다.
HDMI2	
DVI / RGB / MAGICINFO IN	DVI IN: DVI 케이블 또는 HDMI-DVI 케이블을 이용하여 외부기기를 연결할 때 사용합니다. RGB IN: PC 연결시 D-SUB - DVI(전용) 케이블 또는 D-SUB 케이블과 D-SUB - DVI 어댑터를 사용합니다. MAGICINFO IN: 네트워크 박스(별매품) 연결시 DP-DVI(전용) 케이블을 사용합니다.
DP IN	DP 케이블을 이용하여 다른 제품을 연결할 때 사용합니다.
DAISY CHAIN	Daisy chain 방식의 케이블을 이용하여 다른 제품과 연결할 때 사용합니다.
RJ45	LAN 케이블을 이용하여 MDC를 연결할 때 사용합니다.

## 문제발생시 해결방안





문제	해결 방안
화면이 나타났다가 사라졌다 해요.	제품과 PC의 케이블 연결 상태를 확인하고, 연결 장치의 잠금 상태를 확인하세요.
화면에 입력 신호가 약하거나 없습니다. 메시지가 나타나요.	제품과 연결된 케이블이 바르게 연결되어 있는지 확인하세요. 제품과 연결된 제품의 전원이 켜져 있는지 확인하세요.
적당하지 않은 모드입니다. 라는 메시지가 나타나요.	그래픽 카드에서 나오는 신호가 제품의 최대 해상도 및 최대 주파수를 넘을 경우에 발생합니다. 표준신호모드표를 참조하여 최대 해상도 및 주파수를 제품 성능에 맞도록 설정하세요.
화면이 흘러내리는 것처럼 보여요.	제품과 연결된 케이블을 확인하세요.
화면이 깨끗하지 못해요. 화면이 흐릿해요.	주파수 조정과 미세 조정을 조절하세요. 부속품(비디오 확장 케이블 등)을 제거한 후 다시 실행하세요. 해상도 및 주파수를 권장 사양으로 조정하세요.
화면이 불안정하고 떨려요. 화면에 그림자 자취가 남아요.	PC나 그래픽 카드의 해상도와 주파수가 제품에서 사용 가능한 범위 내에 설정되어 있는지 확인한 후 제품 메뉴의 부가정보와 표준신호모드표를 참조하여 다시 화면 설정을 하세요.
화면이 너무 밝아요. 화면이 너무 어두워요.	밝기와 명암을 조절하세요.
화면의 색상이 일정하지 못해요.	메뉴의 화면에서 색 재현 범위 메뉴를 조절하세요.
흰색처럼 보이지 않아요.	메뉴의 화면에서 화이트 밸런스 메뉴를 조절하세요.
소리가 안나와요.	음향신호 연결코드의 연결상태를 재확인하거나 음량을 조정해 보세요. 음량을 확인해 보세요.
소리가 너무 작아요.	음량 조절을 최대한 해도 소리가 작다면 PC 사운드 카드나 소프트웨어 프로그램의 음량을 다시 조절하세요.

문제	해결 방안
화면은 나오는데 소리가 나오지 않아요.	민약 HDMI 케이블을 이용하여 연결한 상태라면, PC에 설정된 오디오 출력을 확인하세요. 음향 메뉴에서 스피커 설정을 내부로 설정하세요. 외부 기기를 사용하는 경우 • 오디오 케이블이 제품의 오디오 입력 단자에 올바르게 연결되어 있는지 확인하세요. • 외부 기기의 오디오 출력 옵션을 확인하세요. (예를 들어, 모니터에 HDMI가 연결되어 있는 경우에는 케이블 박스의 오디오 옵션을 HDMI로 변경해야 할 수 있습니다.)
DVI-HDMI 케이블을 이용하여 연결한 상태라면, 별도의 오디오 케이블이 필요합니까.	DVI-HDMI 케이블을 이용하여 연결한 상태라면, 별도의 오디오 케이블이 필요합니다.
제품에 헤드폰 단자가 있는 경우에는 헤드폰 단자에 아무것도 연결되지 않았는지 확인하세요.	제품에 헤드폰 단자가 있는 경우에는 헤드폰 단자에 아무것도 연결되지 않았는지 확인하세요.
기기의 전원 케이블을 다시 연결해서 연결된 기기를 재부팅 하세요.	기기의 전원 케이블을 다시 연결해서 연결된 기기를 재부팅 하세요.
리모컨이 작동하지 않아요.	건전지의 +/- 위치를 확인하세요. 건전지가 다 소모되었는지 확인하세요. 정전된 것은 아닌지 확인하세요. 전원 케이블이 연결되어 있는지 확인하세요. 주변에 특수 형광 및 내온사인 등이 켜져 있는지 확인하세요.
메뉴에서 자막이 선택할 수 없는 회색으로 표시돼요.	TV 의 다른 소스 선택 시에는 화면 표시 메뉴에서 자막을 선택할 수 없습니다. 자막은 외부 기기에서 활성화해야 합니다.
PC 부팅 시 "삐뽀" 소리가 나요.	PC 부팅 시 "삐뽀" 소리가 울리면 PC 본체를 서비스 받으세요.
PC 해상도를 바꿀 때, 지원하지 않는 모드입니다라고 나타날 수 있습니다. 라는 메시지가 나타나요.	입력 신호의 해상도가 디스플레이의 동작 범위보다 경우, 지원하지 않는 모드입니다라고 나타날 수 있습니다. 이 문제를 해결하기 위해서, PC의 해상도를 디스플레이가 지원하는 정도의 해상도로 변경하세요.



## 안전을 위한 주의사항

### 표시 내용

	<b>경고</b>	지키지 않았을 경우 사용자가 사망하거나 중상을 입을 수 있습니다.
	<b>주의</b>	지키지 않았을 경우 사용자가 부상을 당하거나 재산상의 손해를 입을 수 있습니다.
	금지를 나타냅니다.	 반드시 지켜야 할 것을 나타냅니다.

### 전원 관련

 이 이미지는 참조용으로 경우에 따라 다를 수 있습니다.

### 경고

손상된 전원 케이블이나 플러그, 헐거은 콘센트는 사용하지 마세요.

- 감전, 화재가 발생할 수 있습니다.

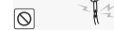

하나의 콘센트에 여러 제품을 동시에 사용하지 마세요.

- 콘센트 이상 발열로 인한 화재의 원인이 됩니다.



전원 케이블을 뽑을 때나 끼울 때 껌은 손으로 만지지 마세요. 감전의 위험이 있습니다.

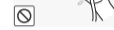

전원 케이블이 흔들리지 않도록 안쪽 끝까지 정확히 꽂아 주세요.

- 결속이 불안정한 경우는 화재의 원인이 됩니다.

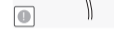

반드시 접지된 콘센트에 전원 케이블을 연결하세요. (절연 1층 기기에 한함)

- 전기적 쇼크(감전) 및 상해를 입을 수 있습니다.

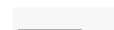

전원 케이블을 무리하게 구부리거나 잡아당기지 마세요. 또한 무거운 물건에 놓이지 않도록 주의하세요.

- 코드가 손상되어 화재, 감전의 원인이 됩니다.

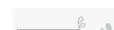

전원 케이블이나 제품을 열기구에 가까이 닿지 않게 하세요.

- 화재, 감전의 원인이 될 수 있습니다.

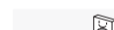
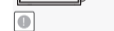
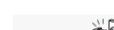
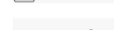
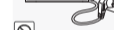
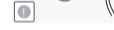
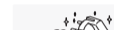

### 설치 관련

### 경고

촛불, 모기향, 담뱃불 등을 제품 위에 올려놓거나 열기구와 가까운 곳에 설치하지 마세요.

- 화재의 위험이 있습니다.

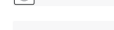
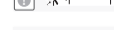
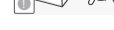
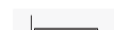
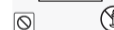

먼지, 습기 (샤우나 등), 기름, 연기가 많은 곳이나 물(빗물)이 튀는 곳, 차양에는 설치하지 마세요.

- 화재, 감전의 위험이 있습니다.

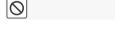
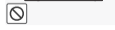
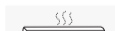
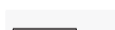
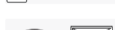
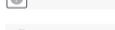
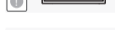
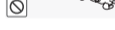
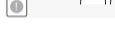
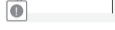
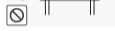
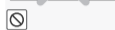
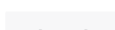
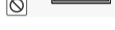
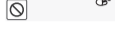
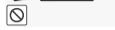
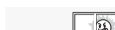

제품을 이동 시 떨어뜨리지 마세요.

- 고장 및 상해를 입을 수 있습니다.

