

P-Series Versatile Tilt Mount Family

Models: **PTDM1, PTDM2**

Weight Capacity: 100 lb / 45.5 kg.

Features

- 1** Easily mounts to walls, and 4.5" Bolt Pattern makes it versatile to use adapters to mount to carts & stands, or suspend from the ceiling
 - 2** Mounts in portrait or landscape orientations
 - 3** Low-profile mount allows displays to be less than 2 inches from their mounting surface
- 10° of continuous downward tilt
 - Open back panel design for easy cable and electrical access
 - Lock-It™ security barrel included
 - Post-installation leveling system
 - Built-in lateral shift
 - Optional extension adapters bring VESA pattern to 600x400 in landscape orientation for PTDM2
 - Mounting kit includes wood and concrete stud attachment hardware

The P-Series Versatile Tilt Mounts are low-profile mounts for flat panels up to 100-lb./45.5 kg., with a display range of 40" & 42" (PTDM1), or 46"-55" (PTDM2). Both models can be mounted to the wall, and also have a 4.5" bolt pattern that make them extremely versatile to use with adapters to suspend from the ceiling, as well as mount to carts and stands. These low profile mounts can be mounted in landscape or portrait orientations. Other features include 10° of downward tilt, post-installation leveling, and built-in lateral shift.

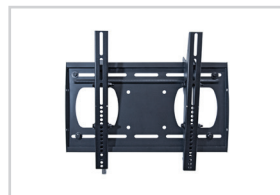

Use one mount for either portrait or landscape mode



Displays sit less than 2 inches from their mounting surface



Mounts to walls, carts and stands, or suspended from the ceiling

P-Series Versatile Tilt Mount Family

PTDM1, PTDM2

Specifications

Weight		Color	Mounting Pattern
PTDM1	12 lb. 5.5 kg	Black	200 x 200 mm (Min) x 300 x 400 mm (Max)
PTDM2	13 lb. 5.9 kg	Black	200 x 200 mm (Min) x 400 x 400 mm (Max)
Width x Height x Depth		Total Weight Capacity	Warranty
PTDM1	14.39 x 16.5 x 1.99 in. 366 x 419 x 51 mm	100 lb. 45.5 kg	Lifetime
PTDM2	20.8 x 16.5 x 1.99 in. 528 x 419 x 51 mm	100 lb. 45.5 kg	Lifetime

Packaging

Width x Height x Depth
18 x 4 x 21 in. 457 x 102 x 533 mm

Contents
Wall Plate (x1), Mounting Bracket (x2), Universal Hardware Pack (x1)

Architectural Drawing

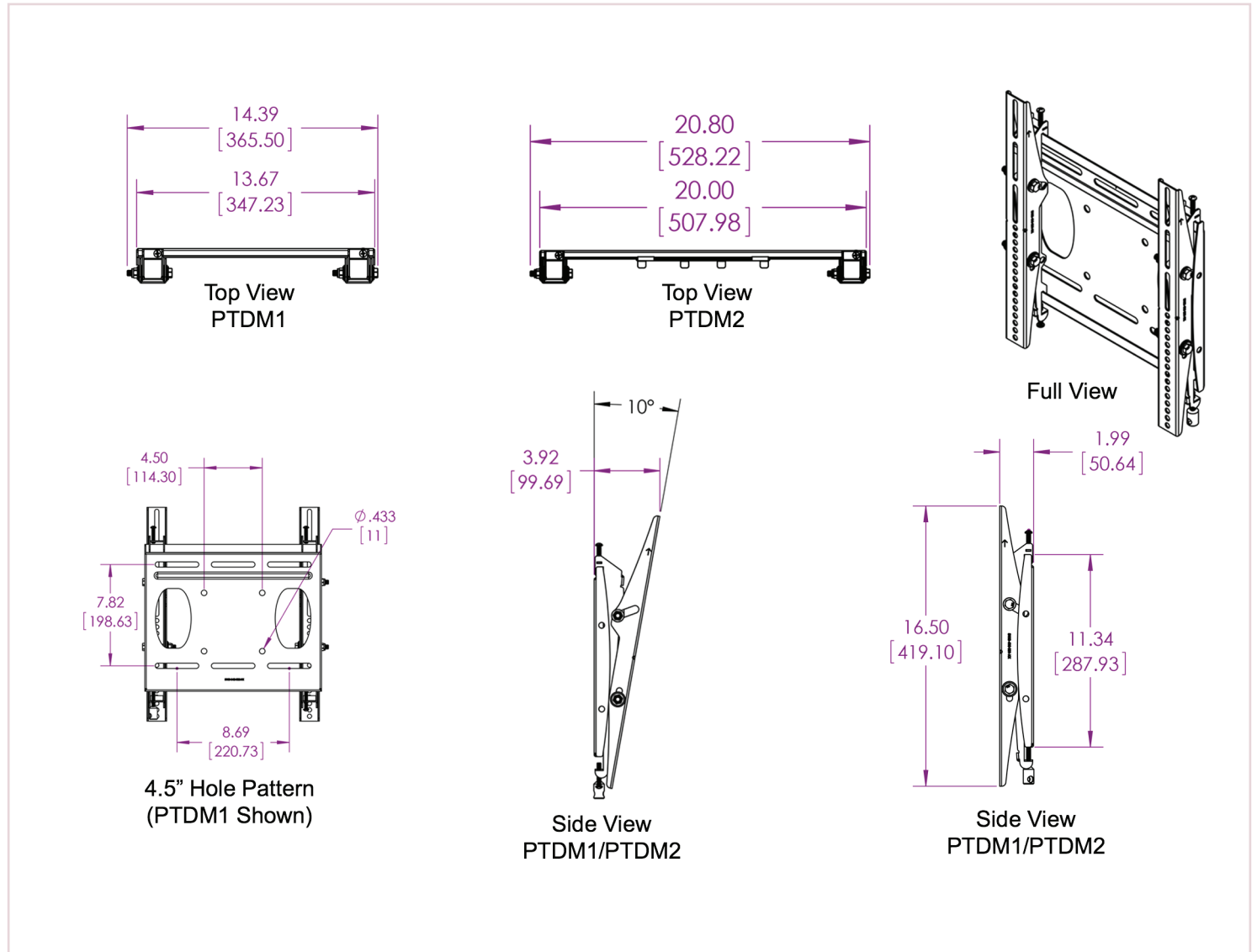

Specifications subject to change without notice