

Articulating Mega Wall Mount for Displays up to 500 lb.

Model: **AM500-U**

Weight Capacity: 500 lb / 227.3 kg.

Features

- 1** Mounting head provides 90 degree rotation capability to the left and right
- 2** Positive and negative tilt (+4.00°/-4.00°) adjustment for a level installation
- 3** 15" extension from the wall for full display access
 - Rotation allows for portrait, landscape or any other angled configuration
 - Dual articulating arms provide weight capacity of up to 500 lb. for any heavy weight display
 - Three different mounting brackets available for different sized displays

The AM500-U is an articulating wall mount for displays weighing up to 500 lbs. Older or just plain heavy displays are no match for the weight this mount can hold. You will be hard-pressed to find a display on the market today that is too heavy for the AM500-U. In addition to its ability to hold large or heavy displays, the AM500-U is an incredibly versatile wall mount. Fully extended the mount sits 24.5 inches from the wall using heavy duty dual arms and is 8.5 in fully collapsed. These articulating arms allow even the heaviest display to be pulled away from the wall with relative ease for service or alignment. Tilt adjustments of +/- 4 degrees are also included. One of the defining features of the AM500-U is its capability to rotate an entire display 90 degrees - from landscape to portrait. Once you find the perfect angle, you can lock the mount into place to avoid unwanted movement. This is easy to do, even with very heavy displays. The mount is great for digital signage, commercial building, command and control, government, and entertainment applications.

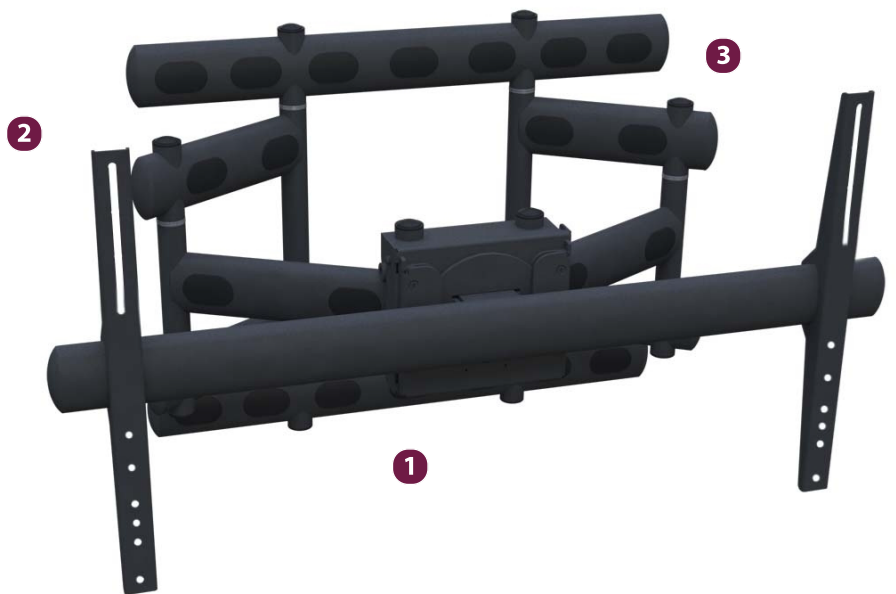

Positive and negative tilt adjustment for multiple viewing angles



90 degree rotation to the left or right for portrait or landscape options



Organized cable management throughout mounting arms

Articulating Mega Wall Mount for Displays up to 500 lb.

AM500

Specifications

Weight 90.15 lb. 41 kg	Color Black	Weight Capacity / Mount 500 lb. 227.3 kg	Mounting Pattern 300 x 200 mm (Min) - 900 x 600 mm (Max)
Width x Height x Depth 41 x 24.41 x 8.52-24.52 in. 1041.4 x 620 x 216.5-622.9 mm		Total Weight Capacity 500 lb. 227.3 kg	Warranty Lifetime

Packaging

Width x Height x Depth
Box 1 46.75 x 11.5 x 4.25 in. 1187 x 292 x 108 mm
Box 2 35.5 x 25.63 x 7.63 902 x 651 x 194 mm

Contents
Fully Assembled Mount (x1), Back Plate (x1), Universal Hardware Pack (x1)

Architectural Drawing

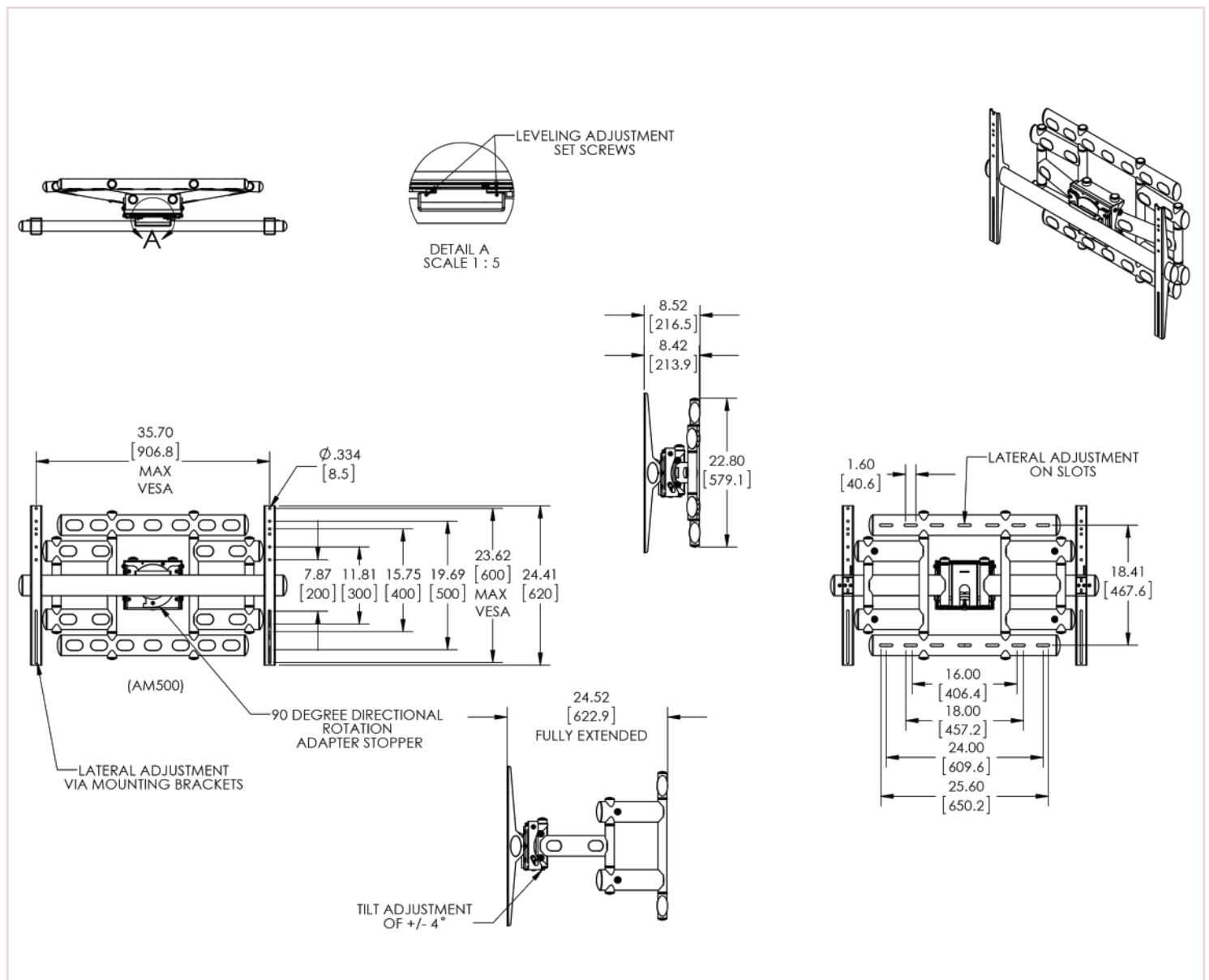

Specifications subject to change without notice