

PRODUCT PLACING MANUAL

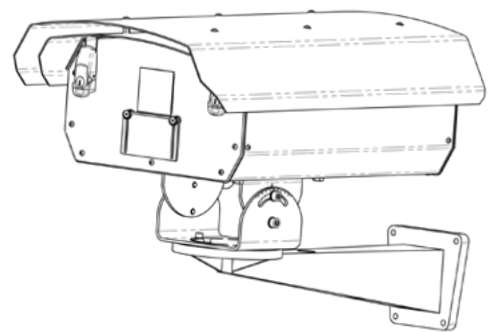

LogoLas FB4 series

Introduction

The **new LogoLas [2020 version]** is a professional laser display system built into an industrial-grade housing, developed for outdoor laser advertising, high visibility signage, facade illumination and crowd flow management applications. With its inbuilt control interface and IP rated robust build, it is a comprehensive solution for permanent installations at demanding environments.

The LogoLas laser projector is suitable for applications such as the replacement of LED strips and neon tubes often used for building illumination and signage, laser billboard projection medium, or fast-to-react tool for public flow control, traffic control and announcements during emergencies.



This laser entertainment system is rated as a **Class IV laser product** and manufactured in accordance to **EN 60825-1:2014**. Avoid eye or skin exposure to direct or scattered radiation. Wear protective goggles of suitable optical density if necessary.



You can install this laser display system on various surfaces, which may require tools such as pliers, wrenches, masonry drill, etc.

We recommend having a minimum of two people available for the installation.



If the laser is operated in a situation where health or property injury may occur the operation must be stopped immediately.



The manufacturer and its distributors cannot be held responsible for any damages caused by improper use or misuse of this KVANT laser system. The owner/user is fully responsible for using this product in accordance to laser safety regulations of the country or state where the system is being used.



Technical drawings

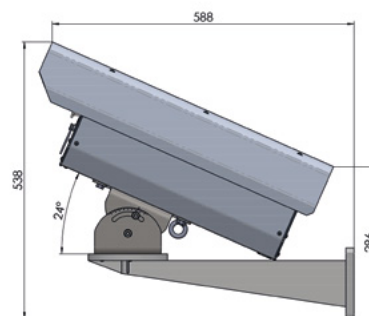
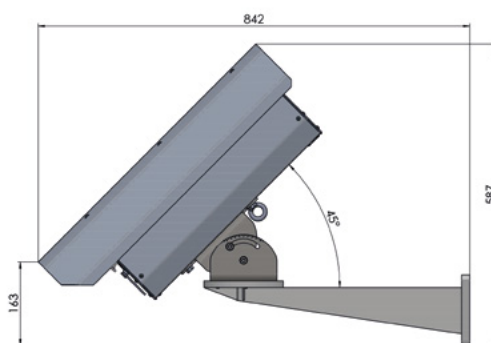
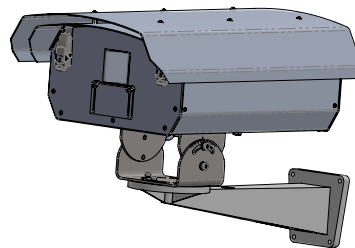
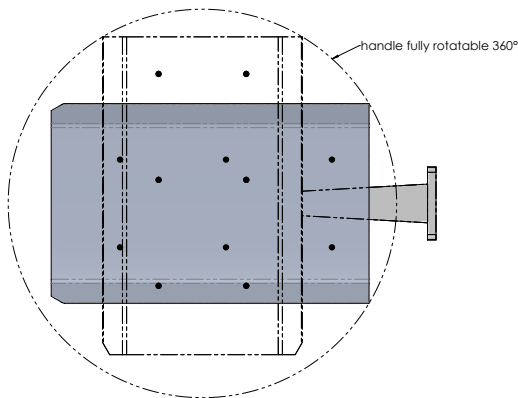
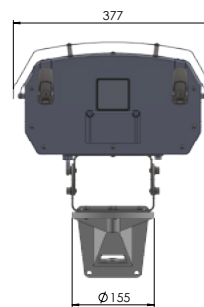
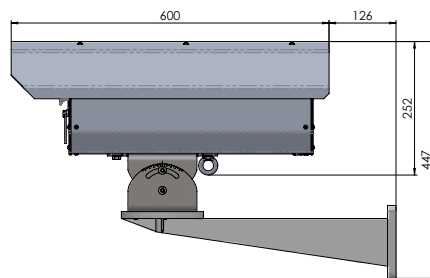

Model:	Logolas 2000	Logolas 3000	Logolas 6000	Logolas G10 OPSL
Guaranteed optical output [mW]:	2 000	3 000	6 000	10 000
R G B [mW]:	340 700 1200	680 900 1500	1300 1800 3000	532 OPSL
Weight [kg]:	21	21	21	21
Size [WxHxD, mm]:	377x252x600	377x252x600	377x252x600	377x252x600

Installation

Installation and mounting on flat surfaces

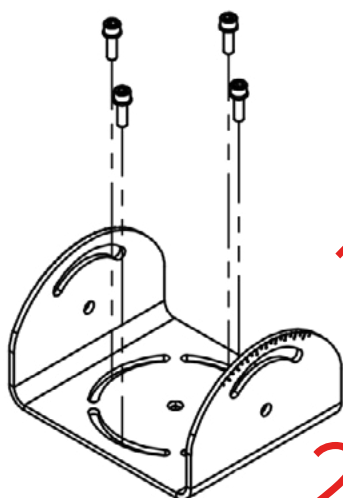

1.

1. Loosen and remove 2 hex-head bolts located on each side of attachment bracket at the bottom of the unit

2a.

2. Remove the bottom part of the bracket, and install it on a suitable flat surface with 5 bolts inserted through the hole and slots (keep them loose)

2b.

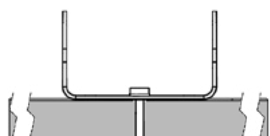

2c.

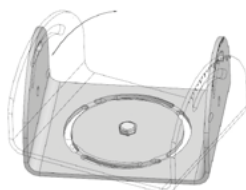

2d.

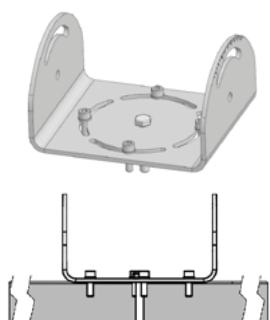

3. Place the LogoLas unit over the bottom part of the bracket and reassemble the 4 hex-head bolts previously taken out (keep them loose)

4. Correct the holder so it is pointing to the direction of the object you want your laser to project to.

3a.

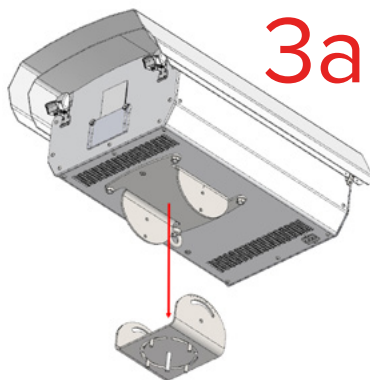

3b.

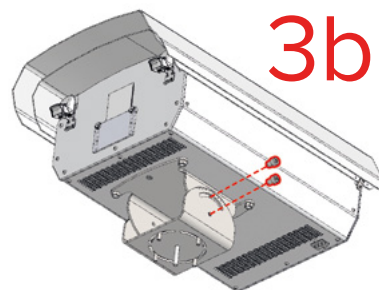

4.

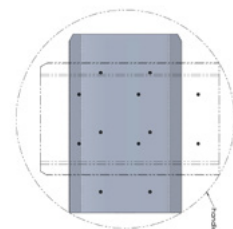
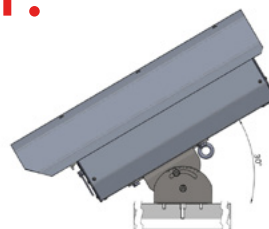
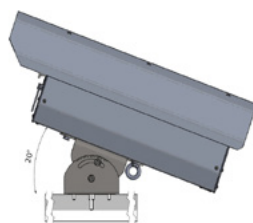

You will find a 1:1 template of placement of the holes for mounting on the last page of this document. You can print it and use it for drilling holes into the wall where the bracket will be mounted.

Installation and mounting on to walls

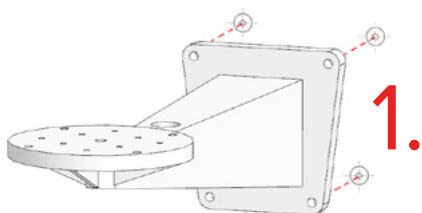

1.

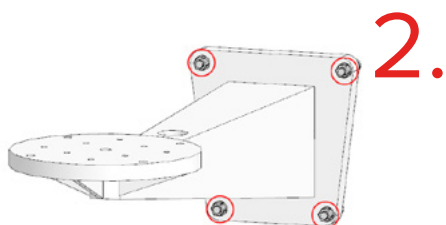

2.

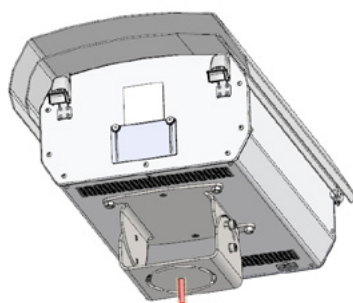

3.

1. Mark holes on the wall surface by using the bracket or the template of placement of the holes for mounting on the last page of this document.
2. Mount the bracket on the wall. We recommend to use adhesive anchors for concrete and masonry.
3. Place a bolt into the middle hole of the bottom holder on your Logolas projector. This way you will easily navigate and place your projector on the bracket.
4. Locate the middle hole on the bracket and place the projector on top and tighten the hex key to ensure your projector will not fall or slip from the bracket.
5. Adjust the tilting, rotation of your laser projector and tighten the bolt
6. Add the remaining side screws for tightening the holder and bracket.

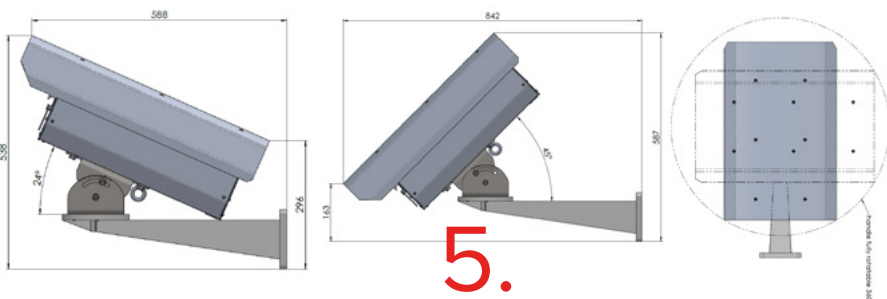

5.

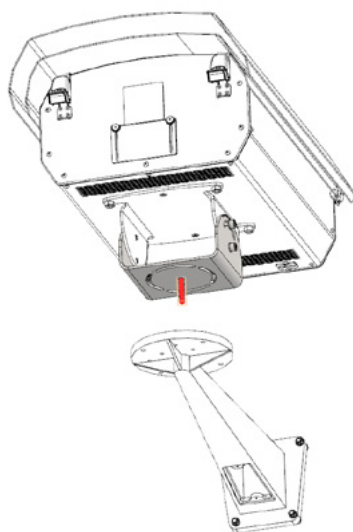

4.

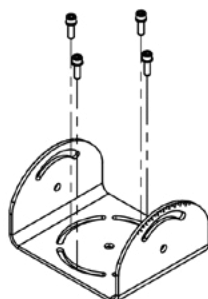

6.

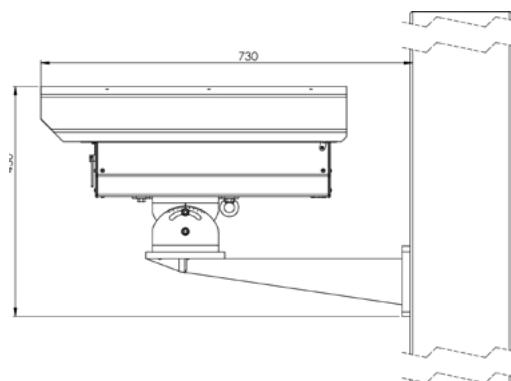

You will find a 1:1 template of placement of the holes for mounting on the last page of this document. You can print it and use it for drilling holes into the wall where the bracket will be mounted.

Installation and mounting on to poles

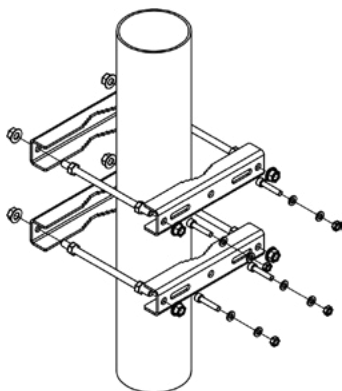

1.

You can also buy the mounting system for flagpoles, street light lamps with diameter from Ø40 to Ø90mm or other profiles of width of 90mm.

1. Mount the console on to chosen object and tighten the bolts. Think in advance where the laser should point to and adjust the console accordingly.

2. Install the bracket on the console using 4 bolts and tighten

3. Place a bolt into the middle hole of the bottom holder on your Logolas projector. This way you will easily navigate and place your projector on the bracket.

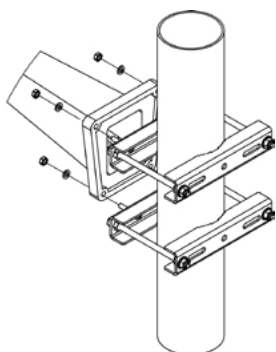

2.

4. Locate the middle hole on the bracket and place the projector on top and tighten the hex key to ensure your projector will not fall or slip from the bracket.

5. Adjust the tilting, rotation of your laser projector and tighten the bolt

6. Add the remaining side screws for tightening the holder and bracket.

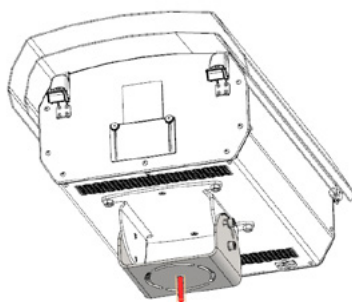

3.

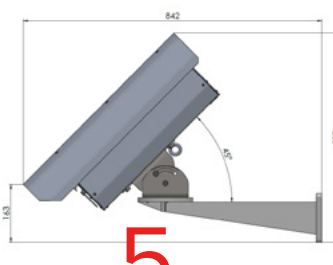
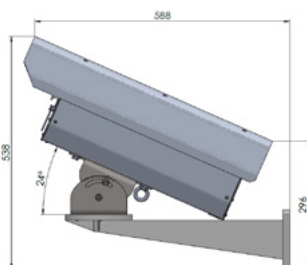

5.

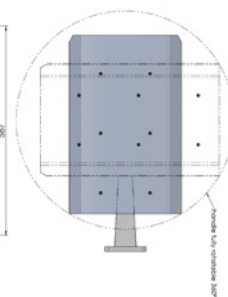

4.

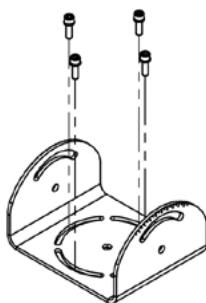

6.

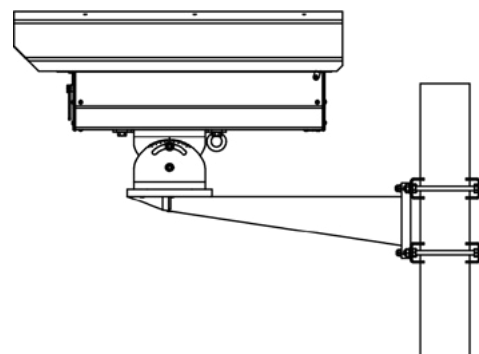



Technical specification

KVANT LogoLas – full colour, semiconductor diode laser system

Laser source	Optically Pumped Semiconductor Laser (OPSL) single colour GREEN laser projector Semiconductor diode full colour RGB laser projector
Suitability	permanent indoor / outdoor laser displays
System control	FB4-SK [Ethernet, ArtNet, Autoplay PC or Lighting Console]
Compliant with	EN 60825 [certification in progress]
Ingress protection rating	IP65
Weight [kg]	21
Size - laser projector [mm]:	377 x 252 x 600 [WxHxD]
Size - incl. bracket [mm]:	377 x 447 x 726 [WxHxD]
Power requirements [V] Input	100-230/50-60Hz
Max. power consumption [VA]	340 - 600
Operation temperature [°C]	0-40 [currently being tested in the range -20 to +40 degrees]

Included in Standard set: „LogoLas laser system, flat surface bracket and wall mount bracket with fixings, 5M power lead, 5M Ethernet rj45 signal cable, E-STOP remote with 5M 3-pin XLR cable, set of 2 keys for the lid and 2 E-STOP keys, interlock bypass dongle [supplied for the USA only], USB memory stick with the user manual. Pangolin QuickShow laser control and creation software is available for FREE download. Everything is safely packed and delivered in a plywood pallet export box.“

HW features: „All the basic system settings and adjustments such as power output adjustment of colour(s), X & Y axes invert, X & Y size and position, etc. are managed via the built-in FB4 control interface. The laser system is equipped with a scanning system overload protection.“

Laser safety features: Keyed interlock, emission delay, magnetic interlock, scan-fail safety, fast electromechanical shutter [reaction time <20ms], adjustable aperture masking plate, Emergency STOP system with keyed remote and manual RESTART button.

note A „*The beam divergence total is calculated as an average arithmetic value of all individual colours. The divergence of each colour is calculated as:

1. FWHM of the beam cross-section for round beams, or
2. The arithmetic average of the beam's horizontal and vertical divergence for all rectangular beams.“

Templates for printing

On the next two pages you will find templates of the console for printing to make the installation easier. Print out the desired template and use it for marking holes in the wall.

“Look before you leap”

Use settings for printing 1:1 or printing without borders to maintain the real size of the template. Use the measurement tool on the template to compare results with tools that measure in millimeters. You can also compare the template with the face of the console, if the holes fit your template. It is said, you should measure twice, before you cut.

4x holes tapping min 25mm
Recommended Minimum M6

