

OASIS® Water Coolers

VERSAFILLER®

Model PWSMSBF

Installation Instructions

The Hands-Free VersaFiller is an extension of the Aqua Pointe® product line.

No electrical connections are required.

The VersaFiller is shipped partially assembled.

When completed, the finished assembly will look like this:

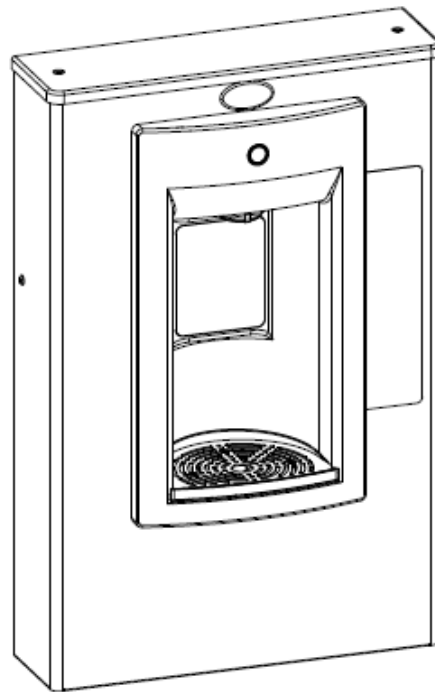

WARNING

•THE WARRANTY FOR THIS MACHINE IS AUTOMATICALLY VOIDED IF THIS MACHINE IS ALTERED, MODIFIED, OR COMBINED WITH ANY OTHER MACHINE OR DEVICE. ALTERATION OR MODIFICATION OF THIS MACHINE MAY CAUSE SERIOUS FLOODING.

•EXCEPT AS SET FORTH HEREIN, THE MANUFACTURER MAKES NO OTHER WARRANTY, GUARANTEE OR AGREEMENT EXPRESS, IMPLIED OR STATUTORY, INCLUDING ANY IMPLIED WARRANTY OR METCHANTABILITY OR FITNESS FOR A PARTICULAR PURPOSE.

Section 1: Getting Started

What's Included:

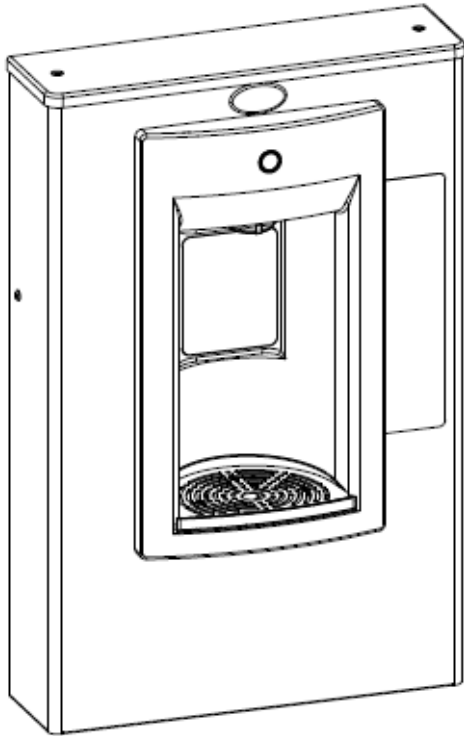

Fitting, reducing union

4" straight tube

Inline strainer

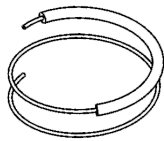

38" of ¼ OD plastic tubing with 19" of sponge tubing insulation

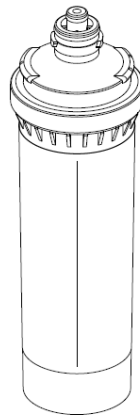

Versafilter II
Versafilter II is optional

Tools required:

- # 2 Phillips screw driver
- #15 torx bit driver

Section 2: Rough In Drawing

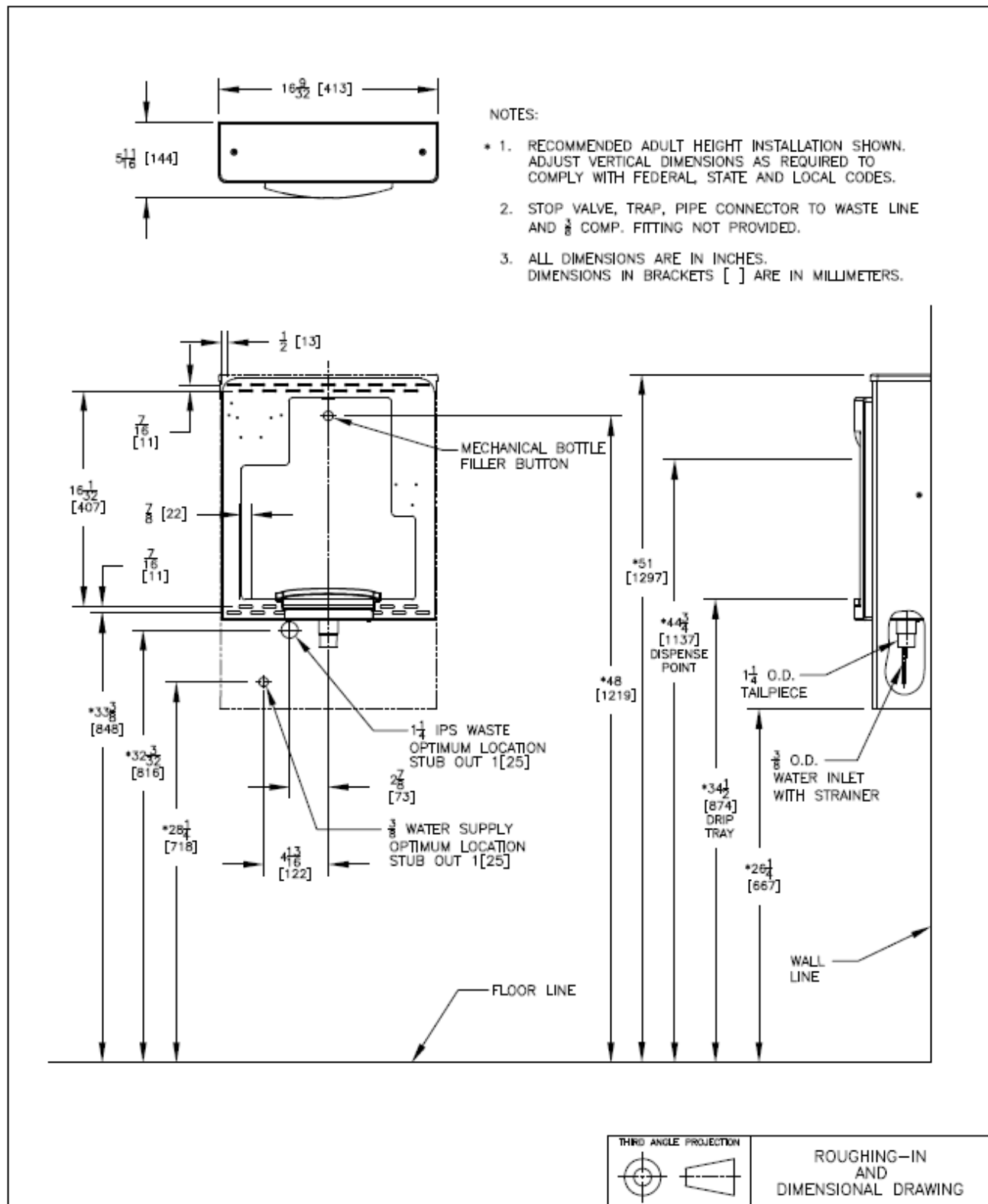

Section 3: Plumbing Diagram

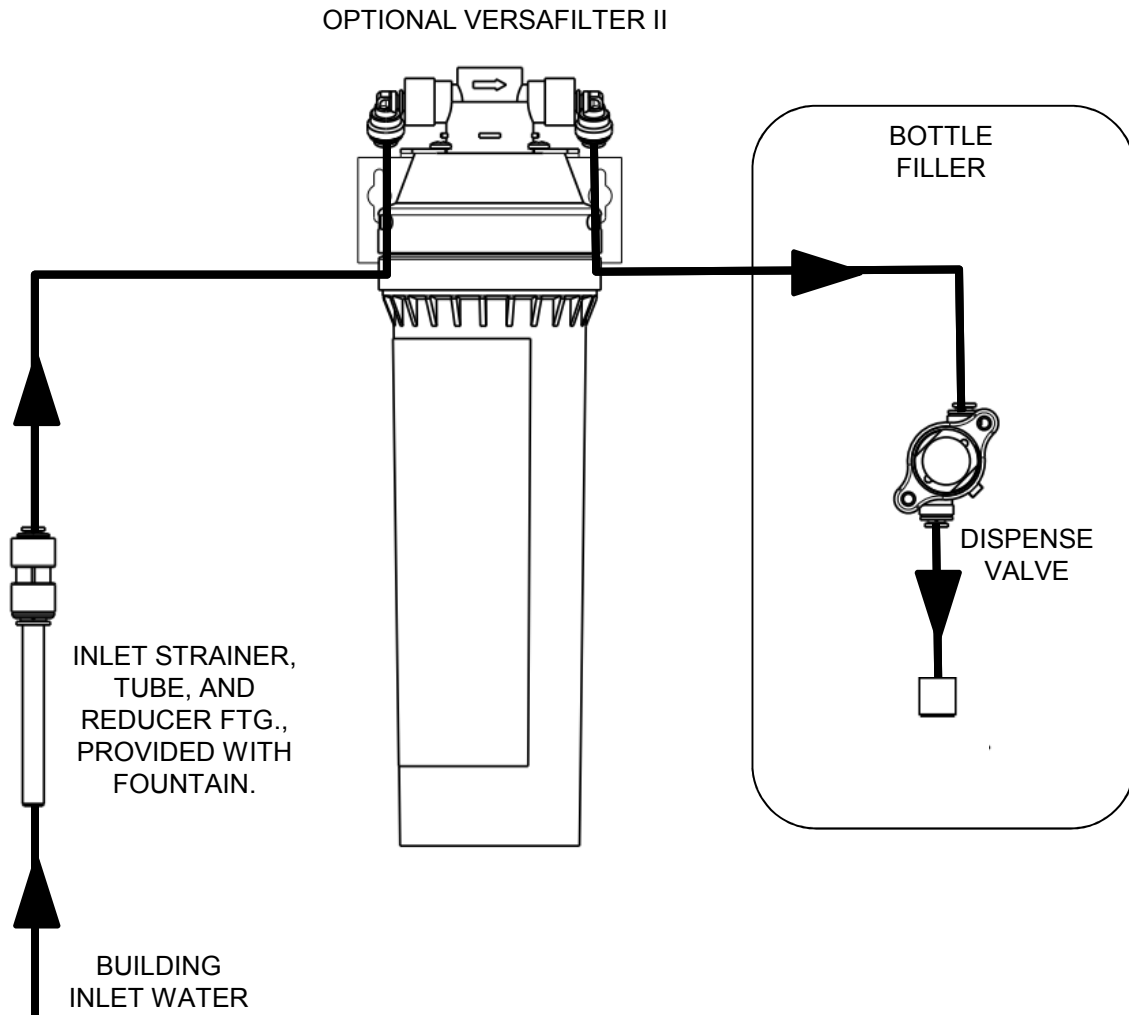

Section 4: Installation

A. INSPECTION

Inspect the cartons and various components for evidence of rough handling and concealed damage. Damage claims should be filed with the carrier.

B. INSTALLATION & PLUMBING CONNECTIONS

1. **Note:** The following states require a licensed plumber to install cooler; AR, GA, MA, MI, OK, RI, SC, SD, TX, VT and WI.
2. CA, KS, MN, NM, and OR allow for state-registered installer or contractor as well. State and local plumbing codes may prohibit use of saddle tapping valves for water line connection in some applications. All connections must conform to applicable plumbing codes.
3. Plumbing rough-in and wall opening should be prepared as shown on Rough-in drawing and template. This drinking water cooler is designed to be operated at a water supply line pressure of up to 100 psi (690 kPa). A pressure regulator must be installed in front of the unit's water inlet if the water pressure (including any possible pressure spikes) could exceed 100 psi (690 kPa).
4. Prep the unit for installation by removing the internal wall frame from cabinet. Remove 2 torx screws (T15) from the sides. Save the screws for reassembly later.
5. Place the wall frame in the appropriate location and attach to the wall. The back panel has 4 rows of slots to provide optimum securing location. NOTE: As the frame is put in place, slide the drain tube into the drain stub extending from the wall.
6. Connect the water supply line. Check plumbing connections for leaks.
7. Assemble the bottle filler cabinet to the frame using the 2 torx screws.
8. On new plumbing installations, run water through the spout until the water taste is satisfactory.

Section 5: Parts Breakdown

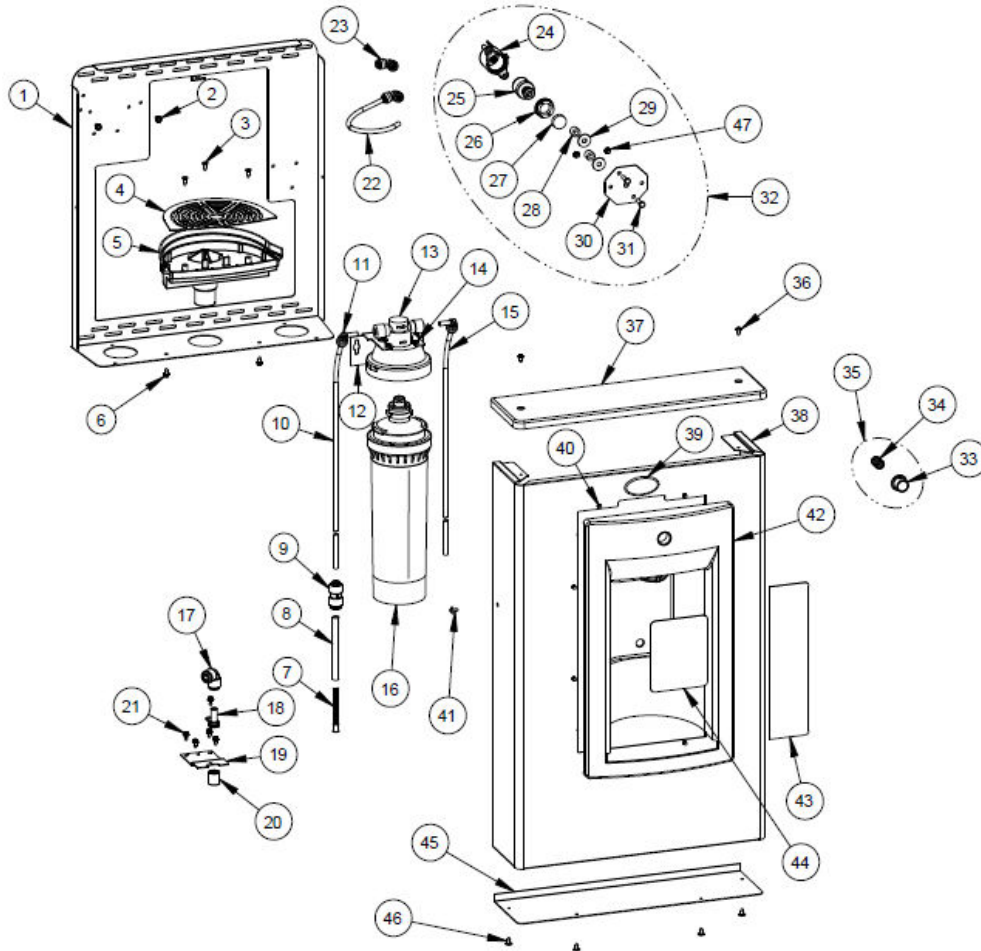

ITEM	QTY	P/N	DESCRIPTION	ITEM	QTY	P/N	DESCRIPTION
1	1	036687-003	FRAME, PWFSBF-K12	25	1	029967-002	CARTRIDGE
2	1	026642-004	SCREW, HEX HD TAPPING	26	1	A020957	NUT, RETAINING PLASTIC
3	3	026675-003	SCREW, FLAT HD TAPPING	27	1	030172-002	PLUG, HOLE
4	1	036192-001	GRILLE, BOTTLE FILLER DRAIN	28	2	028706-036	WASHER, SPACER, NON METAL
5	1	036191-001	DRAIN, MSBF	29	2	016377-042	WASHER/SPACER, METAL
6	2	026642-003	SCREW, HEX HD TAPPING	30	1	036690-001	BRACKET, VALVE PWSBF
7	1	033264-003	STRAINER, IN-LINE	31	2	026670-007	SCREW, HEX HD MACHINE
8	1	026794-014	TUBE, STRAIGHT (4")	32	1	036231-001-SP	VALVE ASSY., PWSBF DISPENSE
9	1	028668-101	FTG, PP REDUCING UNION	33	1	036194-002	BUTTON, PWSBF
10	1	030152-046-SP	TUBE, PE WHITE 38"	34	1	034649-001	SPRING
11	2	028481-101	FTG, PP UNION, ELBOW WHT 0.25	35	1	036702-001	BUTTON ASSY., PWSBF SERVICE
12	1	041073-001	BRKT, VERSAFILTER II (OPTIONAL)	36	2	031875-003	SCREW, TRUSS HD TAPPING TORX
13	1	041072-001	FILTER HEAD, VERSAFILTER II (OPTIONAL)	37	1	036686-001	CAP, PWSBF
14	4	026630-022	SCREW, PAN HD TAPPING (OPTIONAL)	38	1	038003-004	WRAPPER, PWSMSBF
15	1	030152-157	TUBE, PE CUT LENGTH WHI 21.0" (OPTONAL)	39	1	031434-014	NAMEPLATE, OASIS
16	1	041071-001	FILTER CARTRIDGE, VERSAFILTER II (OPTIONAL)	40	8	026642-003	SCREW, HEX HD TAPPING
17	1	028668-101	FTG, PP REDUCING UNION	41	2	031875-003	SCREW, TRUSS HD TAPPING TORX
18	1	038029-001	ADAPTER, FLOW NOZZLE	42	1	036190-003	ALCOVE, EBF
19	1	036209-003	BRACKET, SBF DISPENSE	43	1	038031-007	LABEL, PANEL (OPTIONAL)
20	1	038032-001	FLOW NOZZLE ASSY	44	1	038031-008	LABEL, ALCOVE SENSOR
21	5	026642-003	SCREW, HEX HD TAPPING	45	1	038004-001	PLATE, WRAPPER BOTTOM
22	1	030152-043	TUBE, PE CUT LENGTH WHI 8.5"	46	4	031875-003	SCREW, TRUSS HD TAPPING TORX
23	2	028481-101	FTG, PP UNION ELBOW WHT	47	2	026642-003	SCREW, HEX HD TAPPING
24	1	035990-001	HOLDER, CARTRIDGE STEM				



222 East Campus View Blvd. • Columbus, OH 43235 U.S.A.
1-800-950-3226
www.oasiscoolers.com

OASIS, Versafilter, Aqua Pointe and Versafilter are registered trademark of LVD Acquisition, LLC dba Oasis International

© 2020 LVD Acquisition
030099-471 Rev C 4/2020