

ELKAY[®]

SPECIFICATIONS

Stone Pedestal Upright Fountain Model LK4591

GENERAL

Pedestal, weather-resistant exposed stone aggregate fountain for year-round beauty with minimum maintenance. Contour-formed stainless steel basin with rounded corners and edges reduces splatter, insures proper drainage and prevents standing waste water.

NO LEAD DESIGN

THIS DRINKING FOUNTAIN COMPLIES WITH THE LEAD-FREE DEFINITION IN THE SAFE DRINKING WATER ACT OF 1986 AND LEAD CONTAMINATION CONTROL ACT OF 1988.

Elkay Drinking Fountains are manufactured with a waterway system utilizing copper components and completely lead-free material. These waterways have no lead because all leaded materials, such as leaded brass, have been removed.

CONSTRUCTION

Bubbler: Single-stream, self-closing, pushbutton operated with integral volume control for maintaining proper stream height. Also includes hood guard and anti-squirt feature.

Automatic Stream Height Regulator: Self-closing assembly is located inside unit to prevent tampering. Unit resists corrosion and liming. A constant stream height is automatically maintained under line pressures that vary from 20 to 105 psi.

Inlet Strainer: Easily cleaned in-line strainer screen traps particles of 140 microns or larger before they enter the waterway.

Water Inlet: 3/8" O.D. tubing.

Drain Outlet: 1-1/4" tube outlet for 1-1/4" slip joint connection.

Access Panel: Manufactured of heavy-gauge steel with vandal-resistant self-locking screws. Baked on enamel protective coating is resistant to wear, moisture, and sunlight. Provides access for easy hook-up of all plumbing connections.

SUGGESTED SPECIFICATIONS

Fountain shall be upright pedestal with exposed stone aggregate. Shall include contoured-formed stainless steel basin to eliminate splashing and standing water, and shall have rounded corners and edges. Projector shall be single-stream with integral hood guard and anti-squirt feature. The manufacturer shall certify the unit to meet the requirements of NSF/ANSI 61/372, and the Safe Drinking Water Act.

Shipping Weight: 155 lbs.

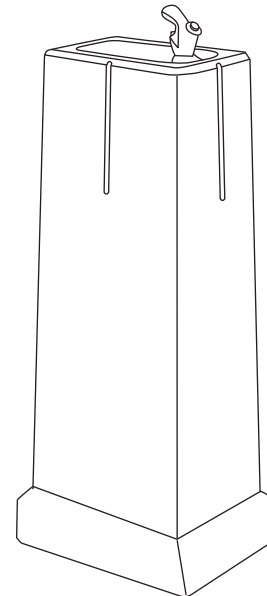

Model LK4591

This fountain is certified by WQA to lead-free compliance including **NSF/ANSI 61 and 372**.



In keeping with our policy of continuing product improvement, Elkay reserves the right to change product specifications without notice.

This specification describes an Elkay product with design, quality and functional benefits to the user. When making a comparison of other producers' offerings, be certain these features are not overlooked.

**Stone Pedestal
Upright Fountain
Model LK4591**

**ELKAY®
ROUGH-IN DIMENSIONS**

**MOUNTING INSTRUCTIONS and
PLUMBING INSTRUCTIONS**

Provide solid, well-drained surface to mount pedestal fountain (concrete pad recommended). (4) 1/2" anchor bolts (not included) should be attached firmly to mounting surface in order to secure fountain. (Refer to rough-in diagram.)

Locate and install plumbing through ground as required.
NOTE: Fountain is not furnished with service valve.

Position pedestal over plumbing and secure base to anchor bolts. Remove access panels and connect supply and water lines. Remember to check your local plumbing and other applicable codes before installation.

Turn on water supply, check for leaks.

Reassemble access panels to pedestal.

Trap and service stop not included.

Operating Pressures: Supply water - 105 psi maximum.

TOP VIEW

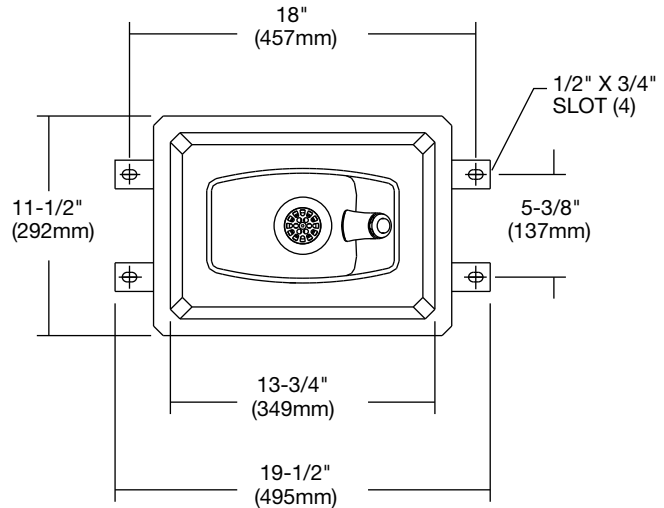

FRONT VIEW

SIDE VIEW

