



OUTDOOR BOTTLE FILLERS

OBF Series

MODEL M-OBF4 OUTDOOR BOTTLE FILLER

STANDARD FEATURES

- All Stainless Steel Construction
- Battery Pack 6AA
- 100 Mesh Inlet Strainer
- Laminar Flow Water Supply
- Hands Free Sensor Operation
- Lead and Cyst Filter
- Meets ADA Forward and Side Reach Requirements

SUGGESTED SPECIFICATIONS

Model M-OBF4 Bottle filler shall be activated by a 9 volt sensor or the push-button as standard. Unit shall contain a 100 mesh inlet strainer, lead and cyst filter, 6-AA battery pack and laminar flow spout. Construction shall be heavy gage, all stainless steel and pedestal base of bottle filler shall have four mounting holes. Access covers shall be secured with vandal-resistant stainless steel screws. A self-closing push-button, needing less than 5 pounds force, shall activate an internally mounted valve. Unit is certified to meet NSF/ANSI 61, Section 9, Public Law 111-380 (No-Lead) and CHSC 116875.

Option Notes:

¹ See separate option sheet

² This option is not available freeze-resistant



Model M-OBF4-PF Shown

MODEL:

(Must Specify)

PUSHBUTTON AND SENSOR OPERATION

- M-OBF4 Satin Stainless Finish
- M-OBF5 Green Powder-Coated
- M-OBF6 Red Powder-Coated
- M-OBF7 Blue Powder-Coated

PUSHBUTTON OPERATION ONLY

- M-OBFM4 Satin Stainless Finish
- M-OBFM5 Green Powder-Coated
- M-OBFM6 Red Powder-Coated
- M-OBFM7 Blue Powder-Coated

Custom color finishes available upon request

OPTIONAL ACCESSORIES

(additional costs may be incurred)

- FRU1 Underground freeze-resistant single valve (push-button operation only, less filter)
- FRU2 Underground freeze-resistant double valves (push-button operation only, less filter)¹
- HB1 Hose bibb with vacuum breaker^{1 2}
- HB3 Vandal resistant Hose bibb with vacuum breaker^{1 2}
- IAP In-ground anchor plate¹
- LOGO Customer specified logo¹
- PF Pet fountain with push-button valve¹



Member of
U.S. Green
Building
Council



Recyclable
Product



Water
Conserving
Product

Please visit www.murdockmfg.com
for most current specifications.

Complies
with the
following
standards:



Federal
Public Law
111-380
(No Lead)



MURDOCK MFG. • 15125 Proctor Avenue • City of Industry, CA 91746 USA
Phone 800-453-7465 or 626-333-2543 • Fax 626-855-4860 • www.murdockmfg.com

Member of
MORRIS GROUP
INTERNATIONAL



OUTDOOR BOTTLE FILLERS

OBF Series MODEL M-OBF4 OUTDOOR BOTTLE FILLER

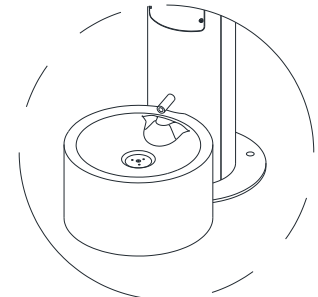
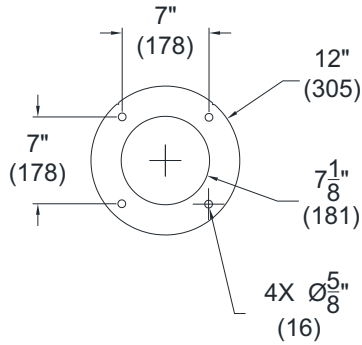

OPTIONAL -PF PET FOUNTAIN
DETAIL

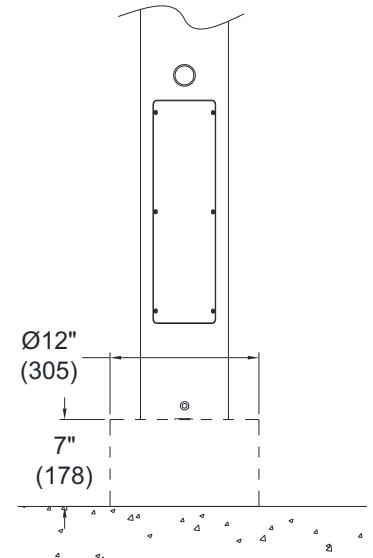
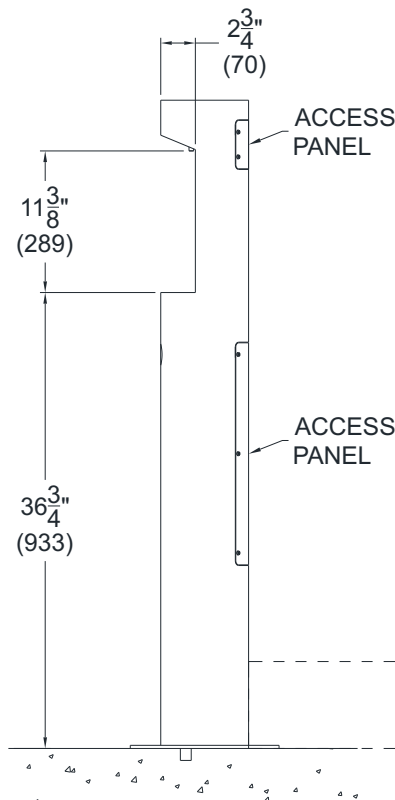
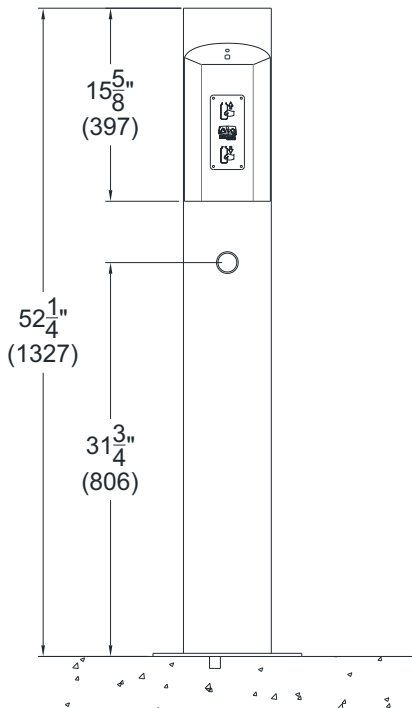

OPTIONAL -PF PET FOUNTAIN

GENERAL DIMENSIONS:

1. ALL DIMENSIONS ARE IN INCHES (MM).
2. STOP VALVE NOT PROVIDED.

ONE YEAR LIMITED WARRANTY - Parts are warranted for one (1) year from date of shipment.

SELECTION SUMMARY
& APPROVAL FOR
MANUFACTURING

Model Number & Options _____	Quantity _____
Company _____	
Contact _____	Title _____
Signature (Approval for Manufacturing) _____	Date _____

All dimensions are nominal and subject to change without notice. Murdock assumes no responsibility for use of void or suspended data.
© Copyright Murdock Mfg, Morris Group International
Please visit www.murdockmfg.com for most current specifications.