



# model 2000SMS

## Surface-Mount Hydration By Haws™ Bottle Filler

### FEATURES & BENEFITS

#### SENSOR OPERATED

Electric sensor allows for touch-free hygienic operation, eliminating the need for manual activation.

#### QUALITY CONTROL

The Haws bottle filling station is pre-built and fully water and pressure tested to ensure no leaks and proper function for reduced installation time and added peace of mind.

#### DURABLE FINISH

#4 satin stainless steel back panel can be easily cleaned and maintained while also resisting corrosion.

#### SERVICING & SECURITY

Durable ABS plastic front panel allows simple access to internal components. 30-second time-out prevents unwanted use. Hidden lock and hinges discourage vandals.

#### ADVANCED FILTRATION

2,500-gallon (9464 L) capacity, electronic lifecycle control filter cartridge will shut off water flow when capacity is reached to ensure fresh, filtered water with every activation. Filter replacement indicator light will flash yellow when filter life is at 10% and will flash red when replacement is necessary. Preparing to replace filter is important when the filter light flashes yellow.

#### EXTENDED WARRANTY

Superior engineering incorporated into this product carries an extended 3 year warranty.



### SPECIFICATIONS

Model 2000SMS Hydration By Haws™ water dispenser is a wall-mounted bottle or cup filling station constructed of durable ABS plastic and 16-gauge, Type 304 Stainless Steel with a satin finish. It features an electric sensor allowing for touch-free hygienic operation, laminar flow to prevent splashing, and a .5 gpm (1.3 L) flow rate for quick fill-up. 2,500 gallon (9464 L) carbon block filter reduces chlorine (taste and odor) and lead, and removes 99.99% of cysts. Hidden lock and hinges on ABS plastic front panel allows access to internal components. The mounting consists of heavy-gauge galvanized steel mounting bracket and hardware, and an adjustable, external electrical cord with maximum length of 6'. 110 volt, 60Hz, and .1 amp draw when in use. A removable water catch basin is provided; this may be converted to a hard-plumbed drain with a retrofit kit.

### APPLICATIONS

The surface-mount Hydration By Haws™ bottle filling station is perfect for mounting on block or solid walls which cannot be cut into and where a recessed mount station is not an option. The surface-mount unit does not require a drain trap and has an integrated drain pan allowing it to be mounted in any location where there is a reasonable access to a water line. Specifically, this bottle filling station is ideal for office buildings, airports, schools, manufacturing facilities and municipalities.

Model 2000SMS meets the Americans with Disabilities Act when mounted at the correct height, and cane bump bar is properly installed (see Operators Manual). Haws manufactures drinking fountains and electric water coolers to be lead-free by all known definitions including NSF/ANSI Standard 61, Section 9, NSF/ANSI Standards 42 & 53, NSF/ANSI 372, and CSA Standard B483.1. Product is compliant to California Health and Safety Code 116875 (AB 1953), California Proposition 65 and the Federal Safe Drinking Water Act. Model 2000SMS is certified to the standard for Water Treatment Appliances (UL979).

### OPTIONS

- Replacement Filter: Model 6423 is the 2,500-gallon (9464 L) replacement filter with electronic lifecycle control for the Hydration By Haws™ Model 2000SMS
- Remote Drinking Fountain Water Chiller: Model HCR8, 8 GPH (30.3 L) remote chiller provides for instantaneous cooling to meet a continuous demand for chilled water.
- Surface-Mount Bottle Filler Drain Kit: Model 6470, optional drain assembly kit for 2000SMS surface-mount bottle filling stations.



THIS DOCUMENT IS TRUE AND CORRECT AT TIME OF PUBLICATION. CONTINUED PRODUCT IMPROVEMENTS MAKE SPECIFICATIONS AND MEASUREMENTS SUBJECT TO CHANGE WITHOUT NOTICE.

**DIMENSIONS OUTSIDE OF WALL:**  
 30-1/4" [768] HEIGHT  
 15" [381] WIDTH  
 6-15/16" [176] DEPTH

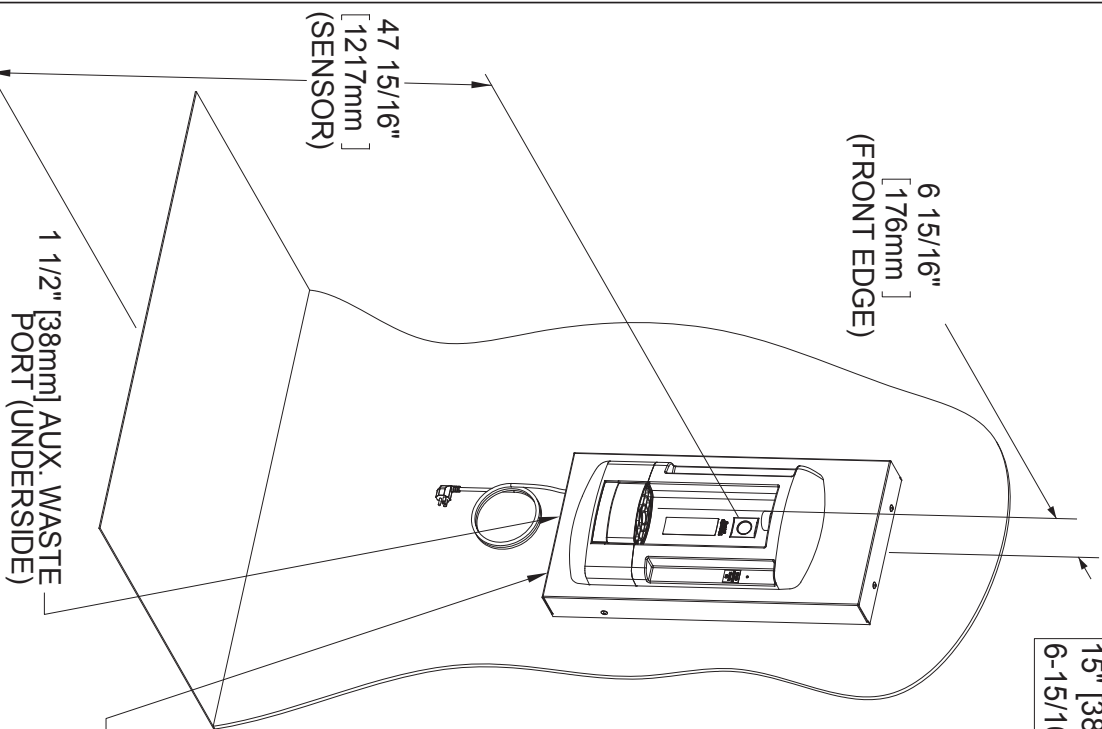

**FRONT VIEW**

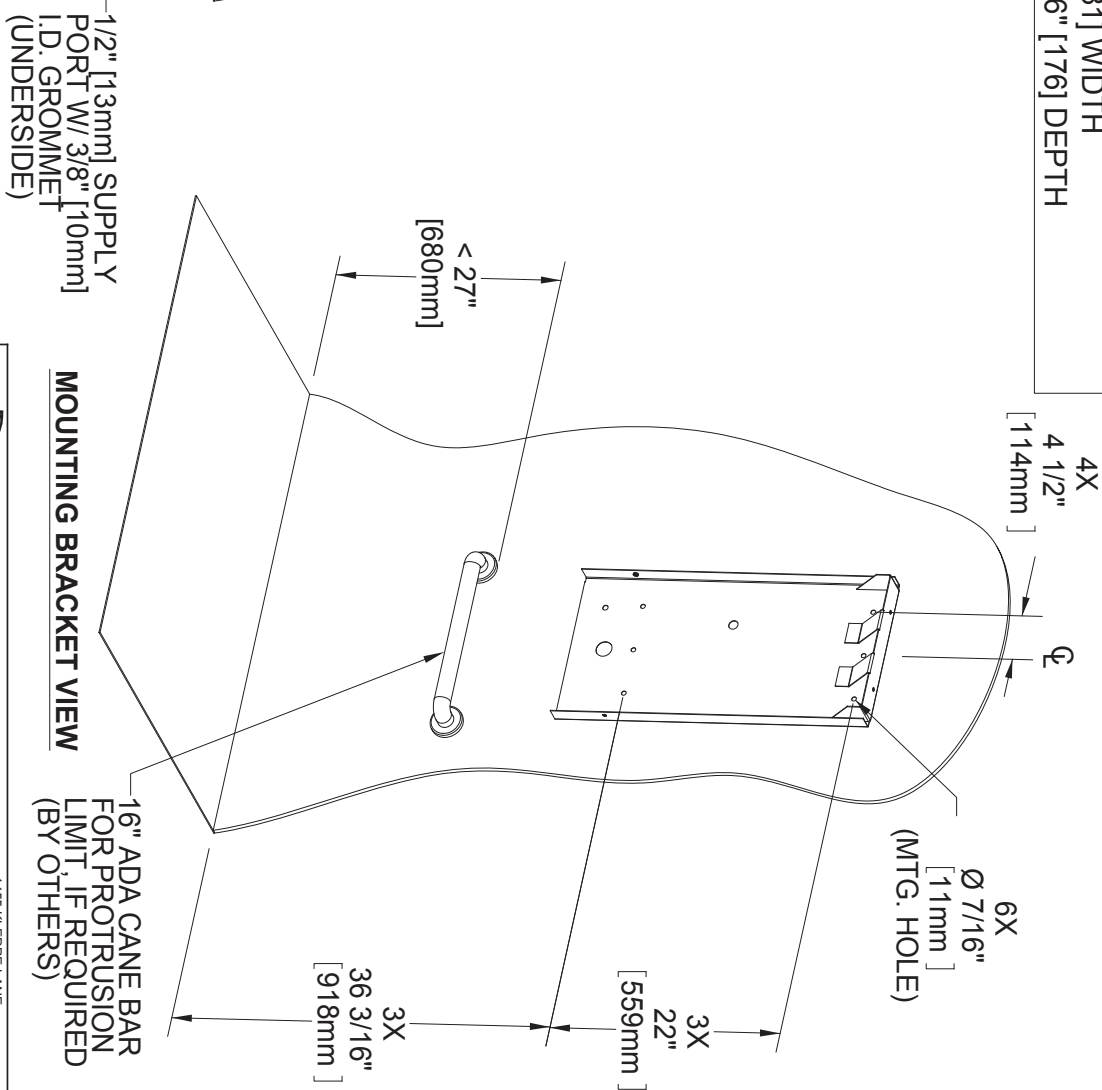

**MOUNTING BRACKET VIEW**



**Haws**

1455 KLEPPE LANE  
 SPARKS, NEVADA, 89431  
 (775) 399-4712 FAX (775) 399-7424  
 E-MAIL: HAWS@HAWSCO.COM  
 WEBSITE: WWW.HAWSCO.COM

ENGINEER	REVISION	PER	DATE	SCALE	MODEL(S)
DL	1	DL	06/15/17	N/A	HAWS BOTTLE FILLER
DRAWN	DATE	SCALE	DATE	SCALE	MODEL(S)
DL	06/15/17	N/A	GC	N/A	HAWS BOTTLE FILLER
APPROVED	DATE	SCALE	DATE	SCALE	MODEL(S)
FV	06/15/17	N/A	GC	N/A	HAWS BOTTLE FILLER
PART NUMBER			INSTALLATION		
0510000664.D			1		
REVISION			SHEET		
1			1 OF 2		

©2017 Haws Corporation - All Rights Reserved. HAWS® and other trademarks used in these materials are the exclusive property of Haws Corporation.