



# model 3500FR

## Barrier-Free Freeze Resistant Pedestal Fountain

### FEATURES & BENEFITS

#### PUSH BUTTON

Polished chrome-plated push-button requires less than 5 lbs. (2.7 kg) of push force to activate.

#### CONSTRUCTION

Superior strength and durability are achieved with the use of 12 gauge Type 304 Stainless Steel, along with integral 3/8" (.95 cm) thick cast stainless bowls. The unit is trimmed with a glossy green powder-coat finish and it is secured to the ground with an integral mounting plate.

#### DRAIN CLEAN-OUT

Top-down access to the drain allows the fountain portion to be cleaned without taking the unit apart, good for outdoor settings with drain-clogging sediment such as leaves, garbage, and other debris.

#### ACCESSIBILITY

Ease of maintenance is achieved with the use of an extra-large access door supplied with heavy-duty door hinges, and is locked by square key pins.

#### FREEZE-RESISTANT VALVE

Fully-engineered system with the pneumatic-operated, freeze-resistant valve installed below frost line to drain water to non-freezing depth allowing fountain to function year round. Assembly can be lifted to surface and lowered back into casing for easy maintenance without disturbing the fountain.

#### BARRIER-FREE

Barrier-free capabilities combined with its ease of use allows for a number of installation location possibilities.

#### BUBBLER HEAD

Polished chrome-plated brass bubbler head with integral basin shank for added strength. Shielded, angled stream opening provides a steady, sanitary source of drinking water at .45 gpm.



### SPECIFICATIONS

Model 3500FR "Hi-Lo" barrier-free, superior-duty vandal-resistant pedestal drinking fountain shall include a 12 gauge Type 304 Stainless Steel pedestal with integral 3/8" (.95 cm) thick cast stainless steel basins, all powder-coated green, polished chrome-plated brass buttons, polished chrome-plated brass vandal-resistant bubbler heads, polished chrome-plated brass vandal-resistant waste strainer with top-down clean-out access, large access door with heavy duty hinges and square key locks, vandal-resistant bottom plate, integral mounting plate, and 1-1/2" slip waste.

REQUIRES MODEL 6518.2FR PRICED SEPARATELY.

### APPLICATIONS

This unique drinking fountain is the perfect addition to parks, rest areas, and correctional facilities where vandalism may be more prone to take place. By welding the bowls directly to the upright, they become one with the unit, preventing removal. That, in addition to many other features for vandal-resistance, makes this fountain virtually indestructible. This series fountain may also be applicable in a wide assortment of other places not mentioned due to its great appeal through its vandal proof and wheelchair accessible design. Model meets all current Federal Regulations for the disabled including those in the Americans with Disabilities Act. Haws manufactures drinking fountains, faucets and electric water coolers to be lead-free by all known definitions including NSF/ANSI/CAN 61-Section 9, NSF/ANSI/ CAN 372, California Proposition 65, and the Federal Safe Drinking Water Act. Product is compliant to California Health and Safety Code 116875 (AB 1953-2006), and NSF/ANSI/CAN 61: Q ≤ 1.

### OPTIONS

- Mounting Plate: Model MTG.3500 mounting plate gives in-ground support for the 3500 series pedestal fountains and includes the mounting hardware.
- Mounting System: Model MTG.3501, galvanized steel anchors.

For more information, visit [www.hawsc.com](http://www.hawsc.com) or call (888) 640-4297.



**NOTES:**

☐ MOUNTING HARDWARE NOT SUPPLIED. SEE PARTS BREAKDOWN DRAWING FOR HARDWARE SUPPLIED WITH EACH OPTIONAL KIT.

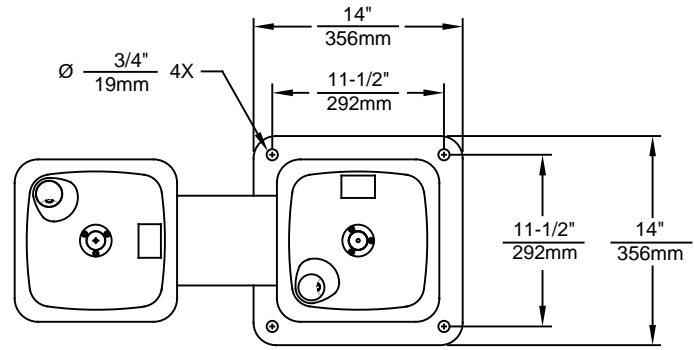

**PEDESTAL MOUNTING DETAIL**

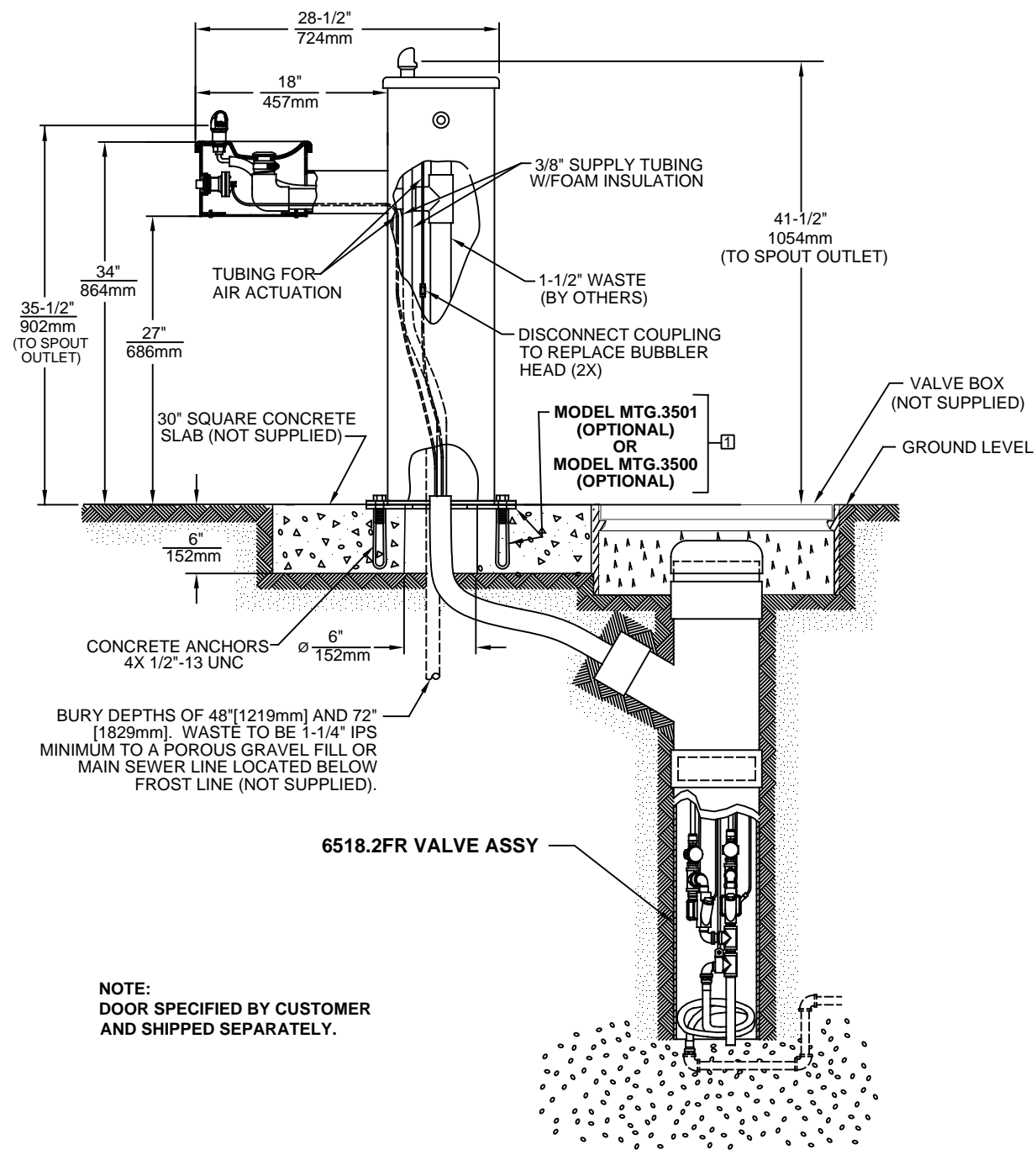

BURY DEPTHS OF 48" [1219mm] AND 72" [1829mm]. WASTE TO BE 1-1/4" IPS MINIMUM TO A POROUS GRAVEL FILL OR MAIN SEWER LINE LOCATED BELOW FROST LINE (NOT SUPPLIED).

**NOTE:**  
DOOR SPECIFIED BY CUSTOMER AND SHIPPED SEPARATELY.

<b>3500FR</b>	
ECN NO. REVISED PER BY: DRAWN: EON: S362 FV/ F. VASQUEZ 6/29/18 JP APPROVED: DATE: 10/23/18 SCALE: 1:16 DRAWING TYPE: INSTALLATION SIZE: A SHEET 1 OF 1	MODEL(S) 3500FR PART NUMBER: 0002077455 D REVISION: 13
1455 KLEPPE LANE SPARKS, NEVADA 89431 (775) 359-4712 FAX (775) 359-7424 E-MAIL: HAWS@HAWSCO.COM WEBSITE: WWW.HAWSCO.COM	