

FEATURES & BENEFITS

CONSTRUCTION

Barrier-free designed fountain for child or adult ADA access. Made of air-entrained concrete with exposed aggregate finish and galvanized wire. Air entrainment ensures strength and freeze-thaw durability. Unit has a stainless steel basin, and hood extension to protect the bubbler head with a partial enclosure. Vandal-resistant bottom plate, and chrome-plated 1-1/2" (3.81 cm) IPS trap.

DRAIN CLEAN-OUT

Top-down access to the drain allows the fountain to be cleaned without taking the unit apart, good for outdoor settings with drain-clogging sediment such as leaves, garbage, and other debris.

BARRIER-FREE

Designed for Adult or Child ADA access, the spacious fountain design allows for the trap to be internally mounted which allows for easy access.

MOUNTING

3/16" (.47 cm) steel mounting plate with supplied mounting hardware for a solid unit base allows for easy installation to a framed wall.

BUBBLER HEAD

Polished chrome-plated brass bubbler head with integral basin shank for added strength. Shielded, angled stream opening provides a steady, sanitary source of drinking water at .45 gpm.

PUSH BUTTON VALVE

The push-button activated valve assembly allows for front access stream adjustment as well as cartridge and strainer access. The valve works at an operating pressure range of 30 to 90 psi (2.1 to 6.2 bar).



SPECIFICATIONS

Model 1047 wall mounted adult or child barrier-free drinking fountain shall include a stainless steel basin contained in a vandal-resistant air-entrained concrete wall bracket with exposed aggregate finish, 100% lead-free waterways, push-button operated valve with front-accessible cartridge and flow adjustment, polished chrome-plated brass vandal-resistant bubbler head, polished chrome-plated brass vandal-resistant waste strainer with top-down access, vandal-resistant bottom plate, and chrome-plated 1-1/2" IPS trap. REQUIRES MODEL 6700 PRICED SEPARATELY.

APPLICATIONS

Perfect for either public or private settings, our concrete series is a great fit in "open-air" environments. Suitable in areas where weather conditions may be cause for concern, this series stands strong from the forest to the beach. Reinforced concrete design not only protects from corrosion, its Portland gray color makes it recognizable enough to locate without compromising the outdoor atmosphere. Specifically, this type of wall mounted drinking fountain may be placed in settings such as: parks, schools, and other recreational outdoor environments where the temperature remains above freezing. Model meets all current Federal Regulations for the disabled including those in the Americans with Disabilities Act. Haws manufactures drinking fountains and electric water coolers to be lead-free by all known definitions including NSF/ANSI Standard 61, Section 9, NSF/ANSI 372, California Proposition 65, and the Federal Safe Drinking Water Act. Product is compliant to California Health and Safety Code 116875 (AB 1953-2006) as evaluated by CSA International.

OPTIONS

- ❑ Support Frame: Model 6800 universal in-wall mounting support for use with most fountains.
- ❑ Remote Drinking Fountain Water chiller: Model HCR8, 8 gph (30.3 L) remote water chiller provides instantaneous cooling to meet a continuous demand for chilled water.

For more information, visit www.hawsc.com or call (888) 640-4297.

THIS DOCUMENT IS TRUE AND CORRECT AT TIME OF PUBLICATION. CONTINUED PRODUCT IMPROVEMENTS MAKE SPECIFICATIONS AND MEASUREMENTS SUBJECT TO CHANGE WITHOUT NOTICE.

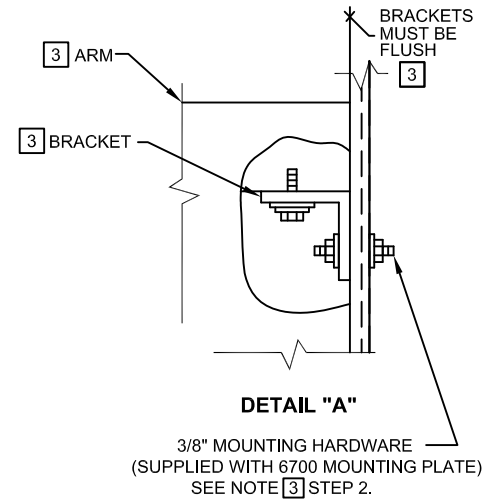
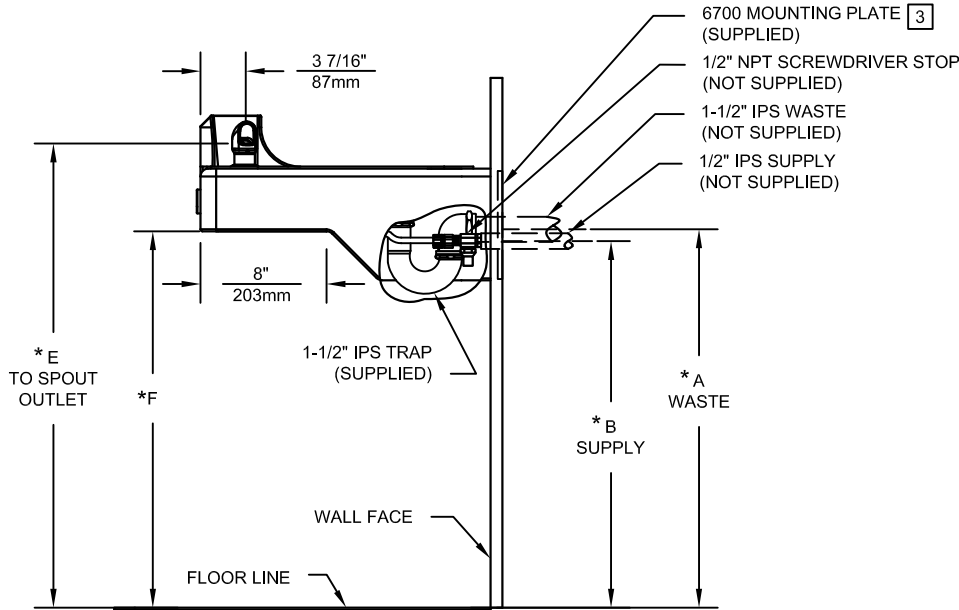
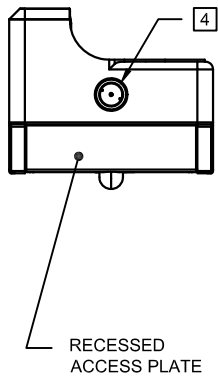
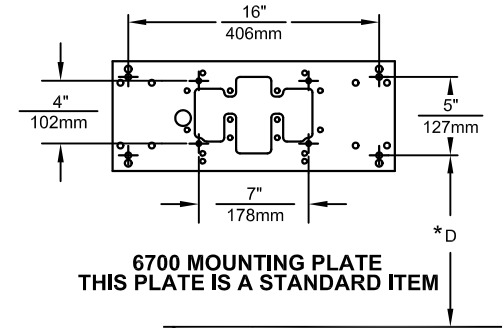
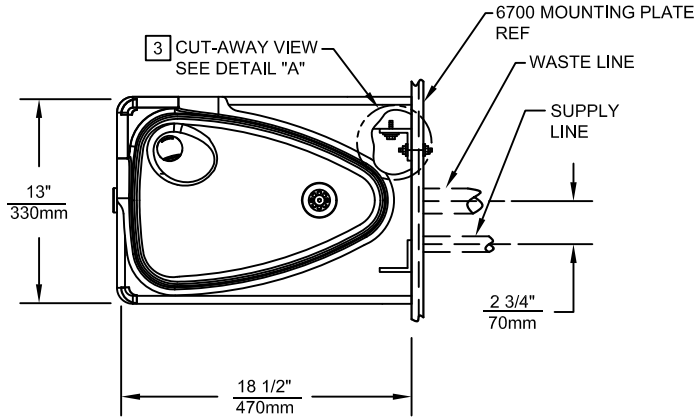
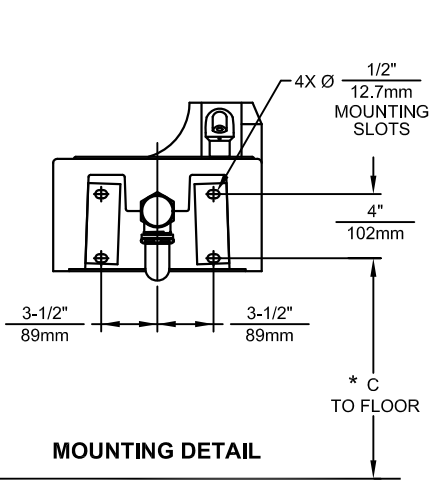

DIM	ADULT ADA	CHILD ADA
A	27-1/2" / 699mm	24-1/2" / 622mm
B	26-3/8" / 670mm	23-3/8" / 594mm
C	25-1/8" / 638mm	22-1/8" / 562mm
D	24-3/8" / 619mm	21-3/8" / 543mm
E	32-3/4" / 832mm	29-3/4" / 756mm
F	27" / 686mm	24" / 610mm

NOTES:

- HOLD ROUGH-IN DIMENSIONS $\pm 1/4"$ (6.4mm).
- WHEN INSTALLING THIS UNIT, LOCAL, STATE OR FEDERAL CODES SHOULD BE ADHERED TO. FOR INSTALLATION HEIGHTS OTHER THAN SHOWN, DIMENSIONS MARKED (*) MUST BE ADJUSTED ACCORDINGLY.
- PROCEDURE FOR ASSEMBLING ARM TO WALL:**
IMPORTANT: L-BRACKETS ARE PRE-ASSEMBLED AND **MUST NOT** BE LOOSENED FOR ANY REASON.
STEP 1: ATTACH ENTIRE ARM ASSEMBLY TO WALL USING 6700 MOUNTING PLATE (SUPPLIED) USING THE 3/8"-16 X 4" THREADED RODS, WASHERS AND NUTS (SUPPLIED WITH 6700 MTG PLT) AND TIGHTEN SECURELY IN PLACE.
STEP 2: (OPTIONAL) APPLY CAULKING AS NEEDED TO FILL ANY GAP PRESENT BETWEEN ARM AND PEDESTAL.
- REFER TO 5874SS OPERATION AND MAINTENANCE MANUAL FOR PUSH BUTTON AND VALVE INSTALLATION/MAINTENANCE INSTRUCTIONS.

Haws

1455 KLEPPE LANE
SPARKS, NEVADA 89431
(775) 359-4712 FAX (755) 359-7424
E-MAIL: HAWS@HAWSCO.COM
WEBSITE: WWW.HAWSCO.COM

ECN NO. 4144	REVISED PER 4725	BY: HM	MODEL(S) 1047	PART NUMBER 0002076418.D
DRAWN: SLS	DATE: 07/22/08	CHKD:	WALL MOUNTED DRINKING FOUNTAIN	DRAWING NO. 10390C00
APPROVED:	DATE:		SCALE: 1:25	REV 19
			DRAWING TYPE: INSTALLATION	SIZE: A SHEET 1 OF 1