

# STAR WARS™

## SERVICE AND OPERATION MANUAL

### WARNING

**IMPORTANT HEALTH WARNING: PHOTSENSITIVE SEIZURES** - A very small percentage of people may experience a seizure when exposed to certain visual images, including flashing lights or patterns. Even people with no history of seizures or epilepsy may have an undiagnosed condition that can cause "photosensitive epileptic seizures" due to certain visual images, flashing lights or patterns. Symptoms can include lightheadedness, altered vision, eye or face twitching, jerking or shaking of arms or legs, disorientation, confusion, momentary loss of awareness, and loss of consciousness or convulsions that can lead to injury from falling down or striking nearby objects.

IMMEDIATELY STOP PLAYING AND CONSULT A DOCTOR IF YOU EXPERIENCE ANY OF THESE SYMPTOMS.

---

Stern Pinball machines are assembled in Elk Grove Village, Illinois, USA. Stern Pinball has inspected each game element to ensure it meets our quality standards.

Each pinball machine has unique characteristics that make it a one-of-a-kind American made product. Each will have variations in appearance resulting from differences in the machine's particular wood parts, individual printed art and mechanical assemblies. No playfield is perfectly flat and varies depending on the season. Game play will result in playfield dimpling as the harder steel ball contacts the wood and coating; over time multiple dimples will blend to make them less noticeable. Normal plastic insert crazing (tiny stress cracks) and ghosting (small cloudy areas around insert edges) are often seen in pinball machines, due to a combination of plastic mold stress, pushing of inserts into purposely undersized holes, and heating and breaking of inserts' plastic "skin" when the playfield field is sanded.

---

REBEL BLOCKADE RUNNER Composed by John T. Williams © 1977 WARNER-TAMERLANE PUBLISHING CORP. (BMI) AND BANTHA MUSIC (BMI) ALL RIGHTS RESERVED. USED BY PERMISSION.

THRONE ROOM (AND END TITLE) Composed by John T. Williams © 1977 WARNER-TAMERLANE PUBLISHING CORP. (BMI) AND BANTHA MUSIC (BMI) ALL RIGHTS RESERVED. USED BY PERMISSION.

THE IMPERIAL MARCH Composed by John T. Williams © 1977 WARNER-TAMERLANE PUBLISHING CORP. (BMI) AND BANTHA MUSIC (BMI) ALL RIGHTS RESERVED. USED BY PERMISSION.

---

© & ™ Lucasfilm Ltd.

---

Games configured for North America operate on 60 cycle electricity only. These games will not operate in countries with 50 cycle electricity (Europe, UK, Australia).



MANUAL #780-50J6-00  
STAR WARS LE #500-55J6-01  
STAR WARS PREMIUM #500-55J7-01

---

1-800-KICKERS - [parts.service@sternpinball.com](mailto:parts.service@sternpinball.com)  
[www.sternpinball.com](http://www.sternpinball.com) - [facebook.com/sternpinball](https://facebook.com/sternpinball)

# TABLE OF CONTENTS

<b>1. Setup and Moving</b>	<b>3</b>	5.11 Slingshot Assembly	42
1.1 First-Time Setup Instructions	3	5.12 Flipper Assembly, Left	43
1.2 Adjustments Menu	6	5.13 Flipper Assembly, Right	43
1.3 Transporting the Game	7	5.14 Pop Bumper Assembly	44
1.4 Maintenance	8	5.15 Pop Bumper Top Assembly	45
1.5 Maintenance Kits	8	5.16 Bumper Ring Top Assembly	45
1.6 Common Parts	8	5.17 Five-Bank Drop Target Assembly	45
<b>2. SPIKE System and Node Guide</b>	<b>9</b>	5.18 Vertical Up-Kicker Assembly	46
2.1 SPIKE System Overview	9	5.19 Up Post Assembly, Long, No Diode	46
2.2 Node Bus Cabling	9	5.20 Fork Ramp Opto Assembly	47
2.3 System Power	9	5.21 Spinner Assembly, Ball Guide Mount	47
2.4 SPIKE Node addresses	9	5.22 Fork Ramp Assembly - Motorized	47
2.5 SPIKE Node Programming	10	5.23 TIE Fighter Spring Assembly	48
2.6 SPIKE System Terminology	10	5.24 TIE Fighter Post Assembly	48
2.7 Common SPIKE Node Boards	10	5.25 Star Wars LE Spot Lamp Assembly	48
<b>3. Light, Switch, and Driver Reference</b>	<b>11</b>	5.26 LCD Display Assembly	49
3.1 SPIKE Node Boards	11	5.27 LCD Display HDMI Cable Assembly	49
3.2 Driver Reference	12	5.28 Up Post Assembly - Long No Diode	49
3.3 Switch Reference	14	5.29 VUK with Spacer Assembly	49
3.4 Light Reference	18	5.30 Millennium Falcon Ship Subassembly	50
3.5 Motor Reference	23	5.31 Compact Diverter Assembly	50
<b>4. Electronic Pinouts and Schematics</b>	<b>24</b>	5.32 Star Wars LE Left Ramp Assembly	51
4.1 SPIKE-2 CPU Node 0	24	5.33 Star Wars LE Right Ramp Assembly	51
4.2 Cabinet Node 1	26	5.34 Death Star LE Main Assembly	52
4.3 Lower Playfield 48V Driver Pinout Node 8	27	5.35 Death Star LE Right Assembly	52
4.4 Mid Upper Playfield 48V Driver Pinout Node 9	28	5.36 Death Star LE Frame Assembly	52
4.5 Through Serial Opto Receiver Extension 8a	29	5.37 Death Star Actuator Assembly	53
4.6 Mode Small LED Board 8b	29	5.38 Death Star Linkage Assembly	53
4.7 Mode Small LED Board 8c	29	5.39 Death Star Light Assembly	53
4.8 Mode Small LED Board 8d	30	5.40 Electric Gate Rail Mount Assembly	54
4.9 Mode small LED Board 8e	30	5.41 Star Wars LE Wire Ramp Assembly	54
4.10 Five Bank LED Board 8f	31	5.42 Electric Gate Back Panel Mount	54
4.11 Right Eject LED Board 9a	31	5.43 Orbit Opto Assembly	54
4.12 Right Ramp LED Board 9b	31	5.44 Ball Guide 01 Assembly	55
4.13 Serial 16 LED Board 9c	32	5.45 Plastic 08L Assembly	55
4.14 Serial Motor Driver Board 9d	32	5.46 Plastic 12L Assembly	55
4.15 SPI core Playfield Node 10	33	5.47 Plastic 20L Assembly	55
4.16 Main Power Supply	33	5.48 Accelerator Exit Diverter Actuator Assembly	56
4.17 Main LED Board 10a	33	5.49 Accelerator Exit Diverter Assembly	56
4.18 Backpanel 48V Driver Pinout Node 11	34	5.50 Accelerator Assembly	56
4.19 Power Distribution Board	35	5.51 Accelerator Coil Spacer Assembly	57
4.20 Power Plug Wiring	35	5.52 Accelerator Coil Spacer Assembly	57
<b>5. Parts Reference</b>	<b>36</b>	5.53 Star Wars LE Back Panel Assembly	57
5.1 Playfield Rubber Parts	36	<b>6. Specifications</b>	<b>58</b>
5.2 Rubber Size Chart	36	6.1 Game Dimensions	58
5.3 Playfield Assemblies, Top	37	6.2 Warranty	59
5.4 Playfield Assemblies, Bottom	38	6.3 Warnings, Compliance, and Legal Notices	59
5.5 Backbox Parts	39		
5.6 Speaker Panel Parts	39		
5.7 Cabinet Parts	40		
5.8 Ball Shooter Assembly	41		
5.9 Auto Launch Assembly	41		
5.10 Ball Trough Assembly	42		



# 1. SETUP AND MOVING

## 1.1 FIRST-TIME SETUP INSTRUCTIONS

Your brand new Stern Pinball Machine is carefully packed for safety and security. For your safety, exercise caution and use the correct tools and sufficient help when setting up your new game.

### TOOLS REQUIRED

- 5/8" Socket Wrench
- Utility Knife
- Snips
- An Assistant

**CAUTION: AT LEAST TWO (2) PEOPLE ARE REQUIRED TO MOVE AND MANEUVER THE GAME. USE PROPER MOVING EQUIPMENT AND EXTREME CARE WHILE HANDLING. STERN PINBALL MACHINES WEIGH OVER 250LBS BOXED.**

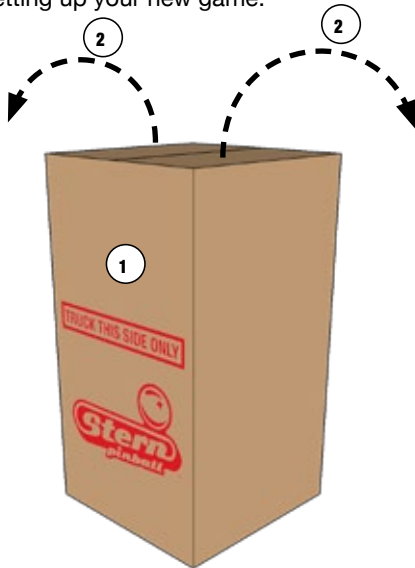

1. Locate the side labeled "TRUCK THIS SIDE ONLY". The bottom of the game faces this side.
2. Open the top box flaps by pulling hard in an upward motion on each flap. If the flaps are taped, cut the tape first, taking care to avoid the box staples.

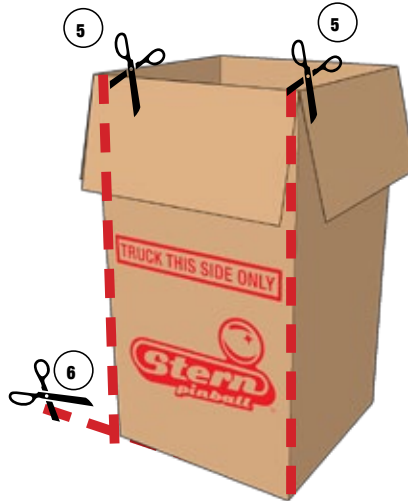

3. Remove the four (4) foam pieces and two (2) narrow box tubes which contain the four (4) identical legs with levelers.
4. DO NOT CUT STRAPPING YET. Keep backbox secured in the down position.
5. With the utility knife, carefully cut down the left and right corners of the box.

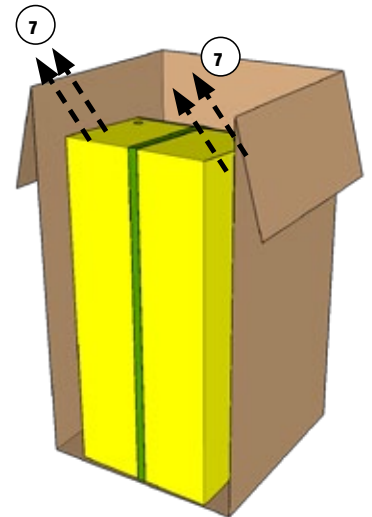

6. Let the face fall forward and remove the entire side by carefully cutting the bottom.
7. With the game still in its folded position, use a 5/8" wrench to loosen and remove the 2 leg bolts on each side of the front cabinet. Ensure the leg levelers are screwed all the way into the legs.

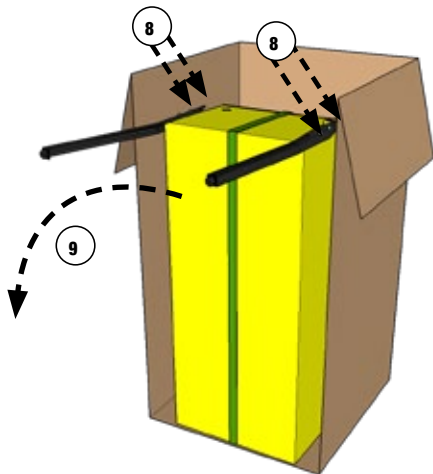

8. Install front legs using the bolts removed from the cabinet. Secure tightly.
9. Have someone help you carefully set the game down on the front legs.

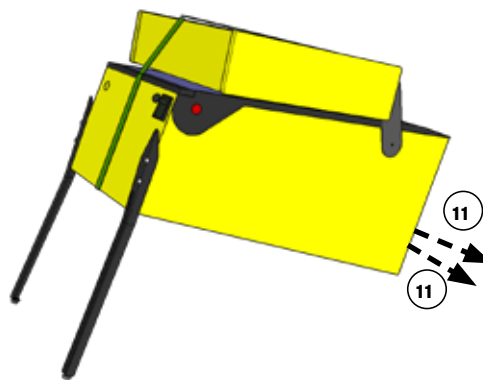

10. Set aside the open box.
11. With a 5/8" socket wrench, loosen and remove the 2 leg bolts on each side of the rear cabinet, 4 total.

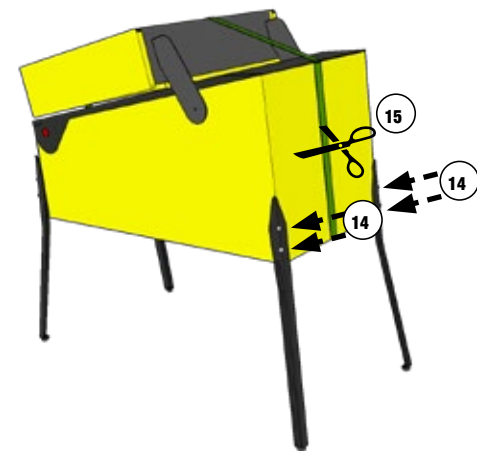

12. Using supports or two people, prop the rear of the cabinet up.
13. Ensure the rear leg levelers are screwed all the way into the legs.
14. Install rear legs using the 4 bolts removed from step 11.



FIRST-TIME SETUP CONTINUED



- 15. Cut nylon strapping and remove protective strap corner guards.
- 16. Locate the factory keys, either on the shooter rod or taped to the playfield glass.
- 17. Using snips, cut the tie-wrap securing the keys if required. One set of keys is for the front coin door, the other set of keys is for accessing components in the backbox.

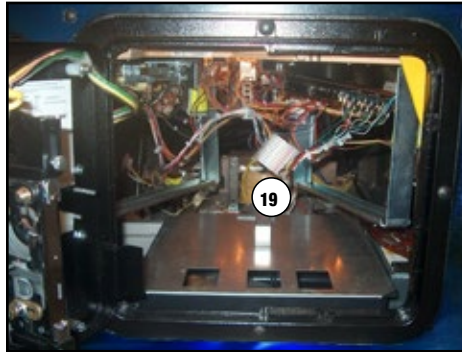

- 18. Open the front coin door.
- 19. Reach into the game and remove the retaining clip at the rear of the cash box.
- 20. Remove the cash box lid by sliding it toward you.

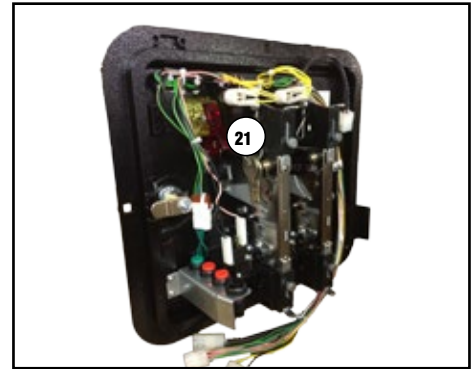

- 21. Store the backbox keys, if desired, on the metal hook located in the coin door.
- 22. Locate and remove the pinballs, plumb bob, and backbox bolts from the cash box.
- 23. Replace the cash box lid and retaining clip for future use.

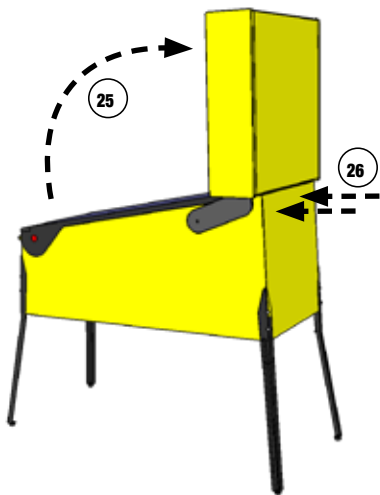

- 24. Locate the two (2) backbox bolts in the cash box.
- 25. Carefully raise backbox to upright position while ensuring that cables are not pinched.
- 26. Use the 5/8" wrench to install the two (2) backbox bolts to secure the backbox as indicated on the back of the cabinet.

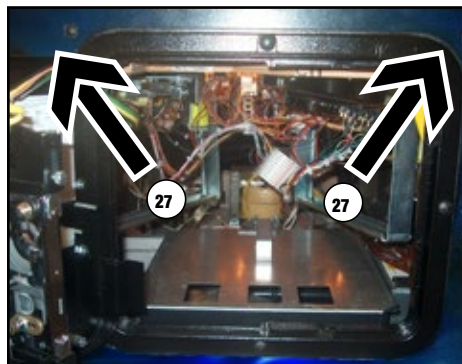

- 27. Reach inside the cabinet and lift the two latches located on either side of the coin door.
- 28. Remove the front top molding.



- 29. Remove the playfield glass by sliding it toward you and carefully place it in a safe location. Remove all playfield shipping tie downs, shipping blocks, and packing foam, and follow any game-specific unpacking instructions included in the playfield, if present.

**CAUTION: PLAYFIELD GLASS IS MADE FROM HIGH-STRENGTH TEMPERED GLASS. TEMPERED GLASS IS SENSITIVE TO EXTREME TEMPERATURE SHIFTS AND CORNER NICKS, WHICH CAN CAUSE THE GLASS TO FAIL CATASTROPHICALLY. TAKE CARE TO STORE THE GLASS ON A SOFT, ROOM-TEMPERATURE SURFACE AND PREVENT THE CORNERS FROM BEING DAMAGED.**

## FIRST-TIME SETUP CONTINUED

30. If pinballs were already installed into the lower ball trough, remove them before lifting the playfield.
31. Grasp the lower arch between the flippers, and firmly but gently pull directly up to raise the playfield 8 to 12 inches.
32. While holding the playfield up, pull the playfield toward you until the two playfield supports are over the front edge of the cabinet.
33. Rest the playfield on the front edge of the cabinet.
34. Raise the playfield and rest it against the backbox.
35. Visually inspect all cabinet cables and connector terminations; ensure no wires or cables are pinched and that cable harnesses are not pulled tight.
36. Locate the plumb bob in the parts bag in the cash box.
37. Slide plumb bob onto the hanger wire. Note: the vertical position of the plumb bob affects tilt sensitivity - higher makes the game more sensitive to tilting.
38. Tighten the thumb screw finger-tight.
39. Install the correct number of pinballs. Refer to the decal on the lock down assembly for the correct number of pinballs.

## LOCATING, LEVELING, AND FINAL SETUP

1. Select a location that is indoors, out of direct sunlight, and climate controlled. Excessive moisture/humidity can cause long-term damage to your game.
2. Adjust the front or rear levelers as necessary to position the playfield level bubble, located on the front right of the playfield next to the shooter lane, to float between the two (2) black lines. This will place the playfield at the recommended 6.5° pitch. Playfield angles greater than 6.5° can be achieved by turning out the rear leg leveler(s) for increased difficulty and faster gameplay.
3. Use a pinball to roll down the center of the playfield for side-to-side leveling, or use an external bubble level, digital level, or smartphone level app.
4. Plug into a grounded outlet and check for proper operation through DIAGNOSTICS.
5. Check the coin door: With the door closed, insert coins to verify proper operation.
6. Play game: Check for satisfactory operation and adjust game volume (push the Red Buttons inside the Coin Door).
7. If desired, perform any game diagnostics, game adjustments, and pricing settings at this time.



## SPIKE PINBALL SOFTWARE UPDATE INSTRUCTIONS

1. Obtain game software update file (filename ends in “.spk”) from [www.sternpinball.com](http://www.sternpinball.com) or from authorized Stern distributor.
2. Place game software update file (“.spk”) in root directory of a blank FAT32-formatted USB flash drive
3. Use backbox power switch to turn off game
4. Plug in USB flash drive to CPU board USB connector (CN20 or CN21). Refer to [www.sternpinball.com](http://www.sternpinball.com)
5. Turn on game
6. The game will automatically begin software update
7. Select the correct .spk update file from list.
8. Press Enter on the service switches to start update
9. When the display indicates “Update Complete”, turn off game
10. Remove USB flash drive from CPU board
11. Turn game on to complete the update and play pinball!
12. Detailed instructions and troubleshooting tips are available in the game manual, [www.sternpinball.com](http://www.sternpinball.com) and authorized Stern distributors.

## 1.2 ADJUSTMENTS MENU

### STANDARD ADJUSTMENTS

Perform the below steps to review the adjustments.

Enter the Service Menu, then enter the Standard Adjustments Menu.

Press SELECT. Press BACK to exit or escape at any time.

Press [>]. Go to the ADJ icon. Press SELECT.

Go to the S.P.I. icon. Press SELECT.

ID	Adjustment Name	Default Setting
1	REPLAY TYPE	AUTO
2	REPLAY PERCENTAGE	10%
3	REPLAY AWARD	CREDIT
4	REPLAY LEVELS	1
5	AUTO REPLAY START	20,000,000
6	DYNAMIC REPLAY START	60,000,000
7	REPLAY LEVEL #1	15,000,000
8	REPLAY LEVEL #2	30,000,000
9	REPLAY LEVEL #3	45,000,000
10	REPLAY LEVEL #4	60,000,000
11	REPLAY BOOST	YES
12	SPECIAL LIMIT	1
13	SPECIAL PERCENTAGE	10%
14	SPECIAL AWARD	CREDIT
15	FREE GAME LIMIT	5
16	EXTRA BALL LIMIT	5
17	EXTRA BALL PERCENTAGE	25%
18	GAME PRICING	USA 11
19	MATCH PERCENTAGE	9%
20	MATCH AWARD	CREDIT
21	BALLS PER GAME	3
22	TILT WARNINGS	2
23	CREDIT LIMIT	30
24	ALLOW HIGH SCORES	YES
25	HIGH SCORE AWARD	CREDIT
26	GRAND CHAMPION AWARDS	1
27	HIGH SCORE #1 AWARDS	1
28	HIGH SCORE #2 AWARDS	0
29	HIGH SCORE #3 AWARDS	0
30	HIGH SCORE #4 AWARDS	0
31	GRAND CHAMPION SCORE	75,000,000
32	HIGH SCORE #1	55,000,000
33	HIGH SCORE #2	40,000,000

STANDARD ADJUSTMENT #1 appears with the adjustment name flashing. While the adjustment name is flashing press [<] [>] to move between adjustments.

To change the adjustment setting press SELECT. While the adjustment setting is flashing, press [<] [>] repeatedly until the desired setting appears. Press the SELECT button to “install” the change. The adjustment comment (bottom line) will indicate if the factory default setting is selected or will display INSTALLED if the change is not a factory default setting.

ID	Adjustment Name	Default Setting
34	HIGH SCORE #3	30,000,000
35	HIGH SCORE #4	25,000,000
36	HSTD INITIALS	3 INITIALS
37	HSTD RESET COUNT	2000
38	FREE PLAY	NO
39	LANGUAGE	ENGLISH
40	PLAYER LANGUAGE SELECT	YES
41	CUSTOM MESSAGE	ON
42	FLASH LAMP POWER	NORMAL
43	COIL PUSLE POWER	NORMAL
44	KNOCKER VOLUME	NORMAL
45	GAME RESTART	YES
46	BILL VALIDATOR	NO
47	MUSIC VOLUME	1
48	BALL SAVE TIME	0:05
49	TIMED PLUNGER	OFF
50	FLIPPER BALL LAUNCH	OFF
51	COINDOOR BALL SAVER	NO
52	COMPETITION MODE	NO
53	CONSOLATION BALL	YES
54	FAST BOOT	YES
55	Q24 OPTION	COIN METER
56	TICKET DISPENSER	NO
57	PLAYER COMPETITION	YES
58	TEAM SCORES	NO
59	LOCATION ID	0
60	GAME ID	0
61	TIME FORMAT	12-HOUR
62	COIN INPUT DELAY	30
63	LOST BALL RECOVERY	YES
64	COIN DOOR DISABLE TILT	NO
65	BACKBOX BRIGHTNESS	100%
66	COIN DOOR OPEN B.BOX BRIGHTNESS	10%

### FEATURE ADJUSTMENTS

Each table has feature adjustments specific to the characteristics of that game. To access feature adjustments enter the Service Menu and then enter the Adjustments Menu.

Press SELECT to access the Service Menu. Press BACK to exit or escape at any time.

Press [>]. Go to the ADJ icon. Press SELECT.

Go to the game icon. Press SELECT.

FEATURE ADJUSTMENT #1 appears with the adjustment name flashing. With the adjustment name flashing press [<] [>] to move between adjustments. Feature adjustments are changed similarly to standard adjustments using the SELECT button to choose options and the [<] [>] buttons to cycle through available settings.

# 1.3 TRANSPORTING THE GAME

When transporting the game, such as in the back of a truck or with a hand truck, the game's backbox must be secured to prevent damage to the side rails.

## 1. SECURE THE BACKBOX

1. Ensure that the pinballs are removed from the playfield, and secure any free-moving mechanisms that may get damaged in transport

**TOOLS REQUIRED** ⓘ

- STRAP (500LB OR GREATER)
- AN ASSISTANT
- HAND TRUCK

**CAUTION** ⚠

**NEVER TRANSPORT THE GAME IN A MOVING VEHICLE WITH THE BACKBOX RAISED! TWO PEOPLE ARE REQUIRED TO REMOVE THE LEGS!**

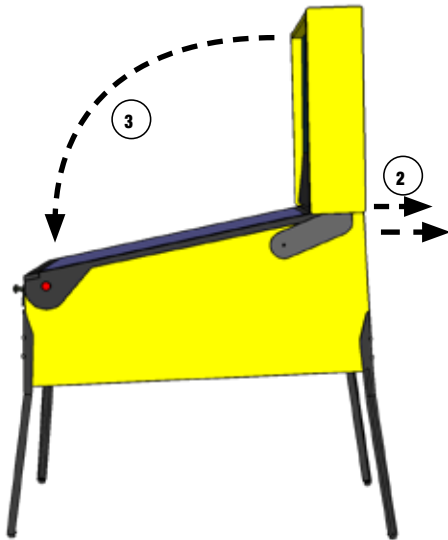

2. Remove the backbox securing bolts
3. Carefully lower the backbox onto the side rails. Use a piece of cardboard or suitable padding between the backbox and the game.

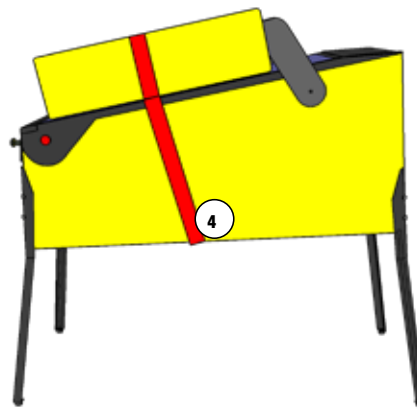

4. Securely strap the back box to the game
5. The game may be transported with the legs on. If the legs must be removed, follow the remaining steps.

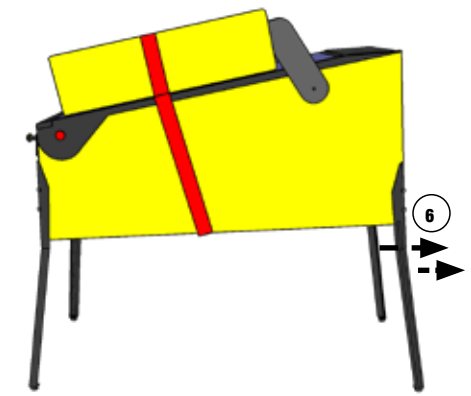

6. Remove the legs, rear legs first. Use a stool or a friend to support the rear of the game.
7. Rest the rear of the game on the ground.

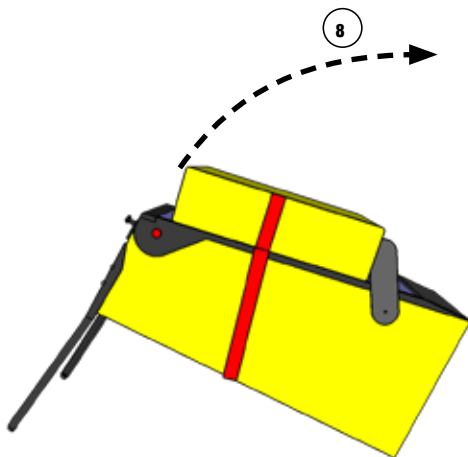

8. Stand the game up on its back.

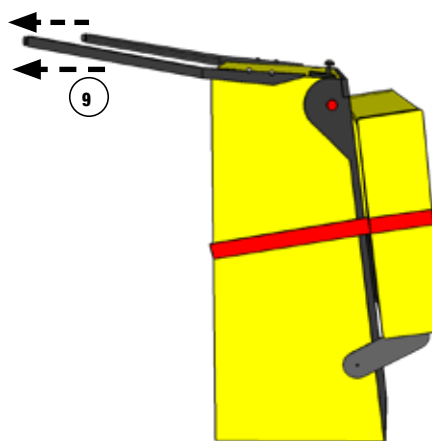

9. Remove the front two legs.

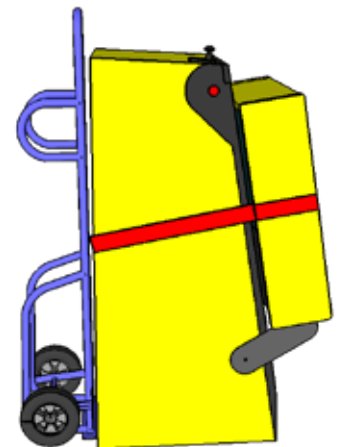

10. Secure all loose parts and transport with a hand truck in the upright position.

## 1.4 MAINTENANCE

### REGULAR MAINTENANCE - (MONTHLY/500 GAMES)

- Remove the playfield glass
- Enter the software diagnostics menu, start lamp test, then clean and wax the playfield.
- ◊ While cleaning the playfield, identify and repair malfunctioning lights, loose parts, cracked plastics and worn rubber parts.
- While in diagnostics, enter the switch test (Select the "SW" Icon, then "TEST" Icon).
- ◊ Use a pinball to actuate all switches and verify the correct switch registers with the switch test.
- ◊ The game will play a sound to confirm the switch.
- Lift the playfield and inspect all assemblies for loose parts, broken wires or excessive wear. Look at the bottom of the cabinet for any parts that may have worked loose, then find the source.
- Check all coin door mechanisms and bill acceptor (if installed) for proper operation
- Play the game to ensure all coils and features are working
- Check the playfield to ensure it is level and set to the proper pitch using the bubble level on the right side wood rail.
- Check game audits: Replay % and Ball Time and note abnormal values which can indicate problems.
- Ensure game volume is set appropriately for the location.
- Clean both sides of the playfield glass and reinstall.
- Check and clean pinballs and replace if excessively worn or scuffed. Dirty pinballs accelerate game wear.

### OVERHAUL MAINTENANCE - (5000 GAMES)

- Verify latest game software is installed
- Check flippers for excessive wear. Excessive flipper sloppiness (vertical or horizontal) or weakness indicates a flipper rebuild is required.
- Clean machine inside and out and check leg levelers for free operation.
- Visual check for loose or broken playfield and cabinet parts and repair as necessary.
- Electrical check: Plug into grounded outlet and check for proper operation through DIAGNOSTICS.
- Replace worn or dirty rubbers.
- Replace pinballs.
- Check all playfield switches with a pinball.
- Check all settings (refer to manual for factory settings).
- Check coin door: With door closed, insert coins to verify proper operation.
- Check for proper adjustment of the plumb bob tilt.
- Play game: Check for satisfactory operation.

### COMMON PINBALL TOOLS

- Common nut drivers (1/4", 5/16", 11/32", 3/8")
- Phillips screwdriver
- Standard Allen wrench/Hex key set
- 3/8" Socket with ratchet
- Adjustable wrench (5/8" & 9/16")
- 6" Torpedo Level (or use a pinball)
- Flashlight or headlamp
- Soldering Iron (60w with flat tip), lead-free solder
- Wire cutter
- Wire stripper
- Long nose ("needle nose") pliers

## 1.5 MAINTENANCE KITS

Description	Part Number
Star Wars LE/Premium Maintenance Kit	502-6002-J6
8 oz pinball playfield wax (Novus # 2) (675-0003-01)	502-6002-J7
Standard Pinball (260-5000-00)	
Cleaning Cloth	
All Playfield Rubber Rings	
Spare Fuses	
Star Wars LE/Premium Deluxe Maintenance Kit	502-6003-J6
All standard kit items, plus:	502-6003-J7
Flipper rebuild kits, Left and Right (500-6307-10,-00)	
Star Wars LE Playfield Plastics Kit	803-5000-J6
Star Wars Premium Playfield Plastics Kit	803-5000-J7
Star Wars LE Playfield Decals Kit	802-5000-J6
Star Wars Premium Playfield Decals Kit	802-5000-J7
Star Wars LE Backbox Decal Left	820-78J6-01
Star Wars Premium Backbox Decal Left	820-78J7-01
Star Wars LE Backbox Decal Right	820-78J6-02
Star Wars Premium Backbox Decal Right	820-78J7-02
Star Wars LE Cabinet Decal Left	820-78J6-03
Star Wars Premium Cabinet Decal Left	820-78J7-03
Star Wars LE Cabinet Decal Right	820-78J6-04
Star Wars Premium Cabinet Decal Right	820-78J7-04
Star Wars LE Cabinet Decal Front	820-78J6-05
Star Wars Premium Cabinet Decal Front	820-78J7-05
Star Wars LE Playfield, Bare	830-5000-J6
Star Wars Premium Playfield, Bare	830-5000-J7
Star Wars LE Mirror Backglass	830-52J6-00
Star Wars Premium Translite Backglass	830-52J7-00

## 1.6 COMMON PARTS

Description	Part Number
8 oz Pinball Playfield wax (Novus # 2)	675-0003-01
Standard Pinball, 1-1/16 in	260-5000-00
Flipper Rebuild Kit Left (Standard)	500-6307-10
Flipper Base Plate Kit Left	515-6617-01
Flipper Rebuild Kit Right	500-6307-00
Flipper Base Plate Kit Right	515-6617-00



## 2. SPIKE SYSTEM AND NODE GUIDE

### 2.1 SPIKE SYSTEM OVERVIEW

The SPIKE Pinball system is a rugged, distributed, and embedded platform custom-designed for the rigors of the pinball machine environment. SPIKE takes advantage of modern technologies to deliver an immersive pinball experience that supports modern features, reduces cabling, and increases serviceability and reliability.

A Stern Pinball machine based on the SPIKE system will have at least two nodes networked together with the SPIKE node bus, a custom industrial pinball control bus that is designed around industry standards and optimized for the pinball environment. The primary CPU node is networked to one or more input/output nodes over standard Category 5 UTP (unshielded twisted pair) ethernet cabling.

There are five primary types of nodes that are found in the game.

- CPU node (Node 0) - The primary node that controls other nodes in the system. Contains the primary game software for the system and provides SPIKE node bus power for other nodes.
- Cabinet 48V node (Node 1) - Specialized node with specific inputs and outputs for coin doors, tilt mechanisms, and other bottom-cabinet devices.
- 48V playfield node - Controls high power devices such as coils and flashers, and also supports a few switch and low-power outputs. Powered by the system 48V power supply.
- Light and switch node - High-density switch and low-power LED outputs, bus-powered from the node bus. These boards contain as many as 32 switch inputs and light outputs.
- Node extensions - These sub-nodes add additional low-power input and outputs to a specific Power or I/O node and are connected with simple serial bus.

### 2.2 NODE BUS CABLING

The SPIKE node bus utilizes standard Ethernet-style RJ45 8-pin modular jacks, and off-the-shelf Category 5e or better ethernet cabling. The node bus is electrically different from Ethernet and does not utilize Ethernet or TCP/IP protocols or signaling standards. SPIKE nodes are not compatible with standard computer networking equipment.

**CAUTION:** Plugging a SPIKE Node or CPU board into a standard Ethernet port may damage one or both devices and void your warranty.

### 2.3 SYSTEM POWER

The SPIKE System is powered from an 48V DC power supply bus. Each SPIKE node converts this voltage to lower voltages required by the node and its specific components. A SPIKE 48V node typically controls high-power outputs such as game coil mechanisms and high-brightness LEDs. These powered nodes are supplied directly with 48V system power. SPIKE standard I/O nodes are low-power nodes that read switch inputs and output to standard-brightness LEDs. Standard I/O nodes use the node bus power, which is supplied by the main CPU node over the node bus modular jack connectors.

### 2.4 SPIKE NODE ADDRESSES

Each SPIKE node has a unique address ranging from 0 to 15. Not all addresses are used in all games. Nodes can be of the same part number, so the address is specified on the DIP switches on each node. When replacing a node, be certain that the correct address is set. Nodes can have 3-position and 4-position DIP switches. Refer to the appropriate table to set the address for each type of Node. The correct address for a node can be found in the SPIKE node reference section of the manual or in the game diagnostic software. Address 0 is reserved for the backbox CPU node, where the game software resides. Address 1 is reserved for the cabinet node, located inside the coin door. These two nodes do not have DIP switches as their address is not configurable.

Address	1	2	3
8	OFF	OFF	OFF
9	OFF	OFF	ON
10	OFF	ON	OFF
11	OFF	ON	ON
12	ON	OFF	OFF
13	ON	OFF	ON
14	ON	ON	OFF
15	ON	ON	ON

SPIKE node addresses for nodes with 3-position DIP switches. Addresses 0-7 are not used by SPIKE nodes with 3-position DIP switches.

Address	1	2	3	4
8	OFF	OFF	OFF	OFF
9	OFF	OFF	ON	OFF
10	OFF	ON	OFF	OFF
11	OFF	ON	ON	OFF
12	ON	OFF	OFF	OFF
13	ON	OFF	ON	OFF
14	ON	ON	OFF	OFF
15	ON	ON	ON	OFF

SPIKE node addresses for nodes with 4-position DIP switches. Addresses 0-7 are reserved for fixed-function nodes and do not require configuration.

## **SPIKE SYSTEM AND NODE GUIDE CONTINUED**

### **2.5 SPIKE NODE PROGRAMMING**

The SPIKE nodes are smart nodes that have on-board processors and run embedded code. The nodes are programmed automatically by the CPU node whenever software updates are installed to the CPU. When replacing a node, the CPU node will detect and update the node to the latest software with no user intervention. Always replace nodes with the power to the game turned OFF.

### **2.6 SPIKE SYSTEM TERMINOLOGY**

#### **MULTI GENERAL ILLUMINATION LIGHTING**

General Illumination Lighting is two or more lights powered by one control source. These are often a number of LEDs connected in parallel and the system controls these as one large LED. A missing LED will not affect these circuits, however a shorted LED can cause the entire string of LEDs to turn off.

#### **SINGLE LIGHTS**

Single lights and LEDs are direct-controlled from SPIKE node boards. A common power source is grounded by individual transistors to turn individual LEDs on and off. Groups of LEDs, usually by node connector, share a common power source, so if a group of LEDs is out, check the wiring for the power source.

#### **FLASHERS**

SPIKE games treat flashers the same as single LEDs that draw more power. Flashers are controlled from the same circuits that power regular lights.

#### **DRIVERS**

A driver is a circuit that controls a high power-device such as a coil, magnet, or motor. Each device has a common 48V power source that is then connected to ground by a dedicated control transistor. Each driver is protected against shorting, static electricity, and over-current conditions. Take caution as 48V is always present on a device even when it is not energized.

#### **OPTOS**

Certain types of optical switches (“optos”) require external signal conditioning. For these optos, they will interface to a SPIKE node via an opto signal conditioning board. Other optical switches connect directly to the Spike node board.

System Protections

**CAUTION:** Unless explicitly directed by an Authorized Stern Repair technician, perform ALL work on your pinball machine with the power disabled!

### **INPUT/OUTPUT PROTECTIONS**

SPIKE features built-in short-circuit, static electricity, and other protections to maximize reliability. If an LED, coil or other device shorts, it will be disabled but will not shut down the entire system in most circumstances. Groups of LEDs, coils, and switches often share common power supplies or other circuits, so it is possible that a bad device will affect the group of related devices and require removal or repair to fix the group. The system diagnostics will inform the technician of shorted or otherwise malfunctioning devices whenever possible. While the system is protected against permanent damage, it is strongly recommended to repair or replace these bad components as soon as possible to minimize downtime and maximize game earnings.

### **2.7 COMMON SPIKE NODE BOARDS**

<b>Description</b>	<b>Type</b>	<b>Part Number</b>
SPIKE CPU Node	Node	509-1000-00
Cabinet Node	Node	520-6967-00
Playfield 48V Core-Driver Node	Node	520-7017-72
Trough Serial Opto Receiver Extension	Extension	520-7001-00

# 3. LIGHT, SWITCH, AND DRIVER REFERENCE

# STAR WARS

PREMIUM/LIMITED EDITION

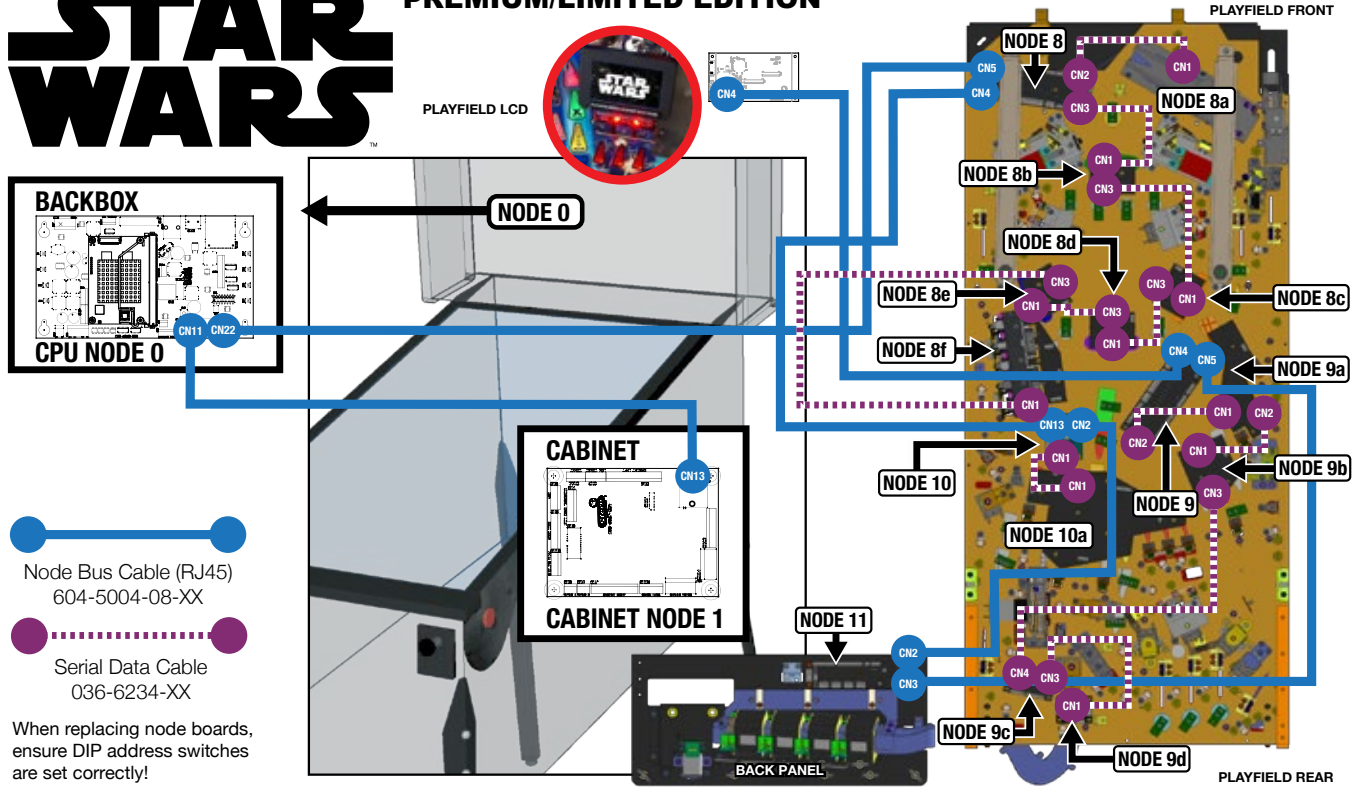

## 3.1 SPIKE NODE BOARDS

ID	DIP Address	Description	Location	Part Number
Node 0	n/a	SPIKE CPU Node	Backbox	520-1003-01
Node 1	n/a	Cabinet Node	Cabinet	520-6967-72
Node 8	OFF-OFF-OFF-OFF	Playfield 48V Core-Driver Node	Lower Playfield	520-7017-72
8a	n/a	Trough Serial Opto Receiver Extension	Playfield	520-7001-00
8b	n/a	Mode Small LED ASY	Playfield	520-7042-00
8c	n/a	Mode Small LED ASY	Playfield	520-7042-00
8d	n/a	Mode Small LED ASY	Playfield	520-7042-00
8e	n/a	Mode Small LED ASY	Playfield	520-7042-00
8f	n/a	Five Bank LED ASY	Playfield	520-7043-00
Node 9	OFF-OFF-ON-OFF	Playfield 48V Core-Driver Node	Playfield	520-7017-72
9a	n/a	Right Eject LED ASY	Playfield	520-7053-00
9b	n/a	Right Ramp LED ASY	Playfield	520-7054-00
9c	n/a	Serial 16 LED Board	Playfield	520-6831-01
9d	n/a	Serial Motor Driver Board	Playfield	520-6996-00
Node 10	OFF-ON-OFF-OFF	SPI Only Node	Playfield	520-6976-72
10a	n/a	Main LED ASY	Playfield	520-7052-00
Node 11	OFF-ON-ON	Playfield 48V 4-Driver Node	Backpanel	520-6998-72



## 3.2 DRIVER REFERENCE

ID	Name	Node	Connector	Ret. Pin	Ret. Wire	Voltage	V+ Pin	V+ Color	Location	Type	Address	Part Number
1	Trough	8	CN8	7	ORG GRY	48V	1-4	GRY ORG	Playfield	Coil - 27-1500	8-DR-1	090-5004-ND
2	Auto Plunger	8	CN8	9	ORG WHT	48V	1-4	GRY ORG	Playfield	Coil - 26-1200	8-DR-4	090-5044-ND
3	Left Flipper	8	CN8	6	ORG YEL	48V	1-4	GRY ORG	Playfield	Coil - 22-1080	8-DR-5	090-5032-ND
4	Right Flipper	8	CN8	5	ORG GRN	48V	1-4	GRY ORG	Playfield	Coil - 22-1080	8-DR-0	090-5032-ND
5	Left Slingshot	8	CN8	11	ORG BLU	48V	1-4	GRY ORG	Playfield	Coil - 26-1200	8-DR-3	090-5044-ND
6	Right Slingshot	8	CN8	10	ORG VIO	48V	1-4	GRY ORG	Playfield	Coil - 26-1200	8-DR-2	090-5044-ND
7	Shaker Motor	1	CN2	1	BLU	48V	5	RED	Cabinet	Motor	1-DR-0	041-5029-04
8	5 Bank Drop Reset	9	CN8	7	YEL ORG	48V	1-4	GRY BRN	Playfield	Coil - 25-1240	9-DR-1	090-5034-ND
9	Lock post	8	CN7	4	YEL BLK	48V	1	GRY ORG	Playfield	Coil - 26-1200	8-DR-7	090-5044-ND
10	Up Post-Loop	9	CN7	3	YEL VIO	48V	1	GRY BRN	Playfield	Coil - 26-1200	9-DR-6	090-5044-ND
11	Death Star	9	CN7	4	YEL GRY	48V	1	GRY BRN	Backpanel	Coil - 24-940	9-DR-7	090-5036-ND
12	L/R Control Gates	9	CN8	6	YEL GRN	48V	1-4	GRY BRN	Backpanel/ PF	Coil - 32-1250	9-DR-5	090-5060-01-ND
13												
14	Left Pop Bumper	9	CN8	10	ORG BLK	48V	1-4	GRY BRN	Playfield	Coil - 26-1200	9-DR-2	090-5044-ND
15	Right Pop Bumper	9	CN8	11	ORG BRN	48V	1-4	GRY BRN	Playfield	Coil - 26-1200	9-DR-3	090-5044-ND
16	Top Sling	9	CN8	9	ORG RED	48V	1-4	GRY BRN	Playfield	Coil - 26-1200	9-DR-4	090-5044-ND
17												
18	Outlane Gate	9	CN7	2	YEL WHT	48V	1	GRY BRN	Playfield	Coil - 32-1800	9-DR-8	515-9980-ND
19	Right Eject	8	CN7	3	YEL BRN	48V	1	GRY ORG	Playfield	Coil - 23-800	8-DR-6	090-5001-ND
20	Diverter	9	CN8	5	YEL BLU	48V	1-4	GRY BRN	Playfield	Coil - 26-1200	9-DR-0	090-5044-ND
21	TIE Fighter	8	CN7	2	YEL RED	48V	1	GRY ORG	Playfield	Coil - 26-1200	8-DR-8	090-5044-ND
22												
23												
24												
25												
26	Accelerator Magnet 1	11	CN5	3	BRN RED	48V	4	GRY BLK	Playfield	Coil - 20-700	11-DR-0	500-6915-00
27	Accelerator Magnet 2	11	CN7	3	BRN ORG	48V	4	GRY BLK	Playfield	Coil - 20-700	11-DR-1	500-6915-00
28	Accelerator Magnet 3	11	CN9	3	BRN YEL	48V	4	GRY BLK	Playfield	Coil - 20-700	11-DR-2	500-6915-00
29	Accelerator Magnet 4	11	CN11	3	BRN GRN	48V	4	GRY BLK	Playfield	Coil - 20-700	11-DR-3	500-6915-00
30												
31												
32												
33	Coin Meter	1	CN3	2	BLK	12V	1	RED	Cabinet	Digital Out	1-DR-2	500-9946-00
34	Ticket Meter	1	CN4	2	BLK	12V	1	RED	Cabinet	Digital Out	1-DR-3	500-9946-00
35	Ticket Dispenser	1	CN11	3		12V	1		Cabinet	Digital Out	1-DR-4	
M-1	Magnet 1 LED indicator	11	CN5	3	BRN RED	48V		GRY RED	Backpanel			112-5034-05
M-2	Magnet 2 LED indicator	11	CN7	3	BRN ORG	48V		GRY ORG	Backpanel			112-5034-05
M-3	Magnet 3 LED indicator	11	CN9	3	BRN YEL	48V		GRY YEL	Backpanel			112-5034-05
M-4	Magnet 4 LED indicator	11	CN11	3	BRN GRN	48V		GRY GRN	Backpanel			112-5034-05

DRIVER REFERENCE CONTINUED

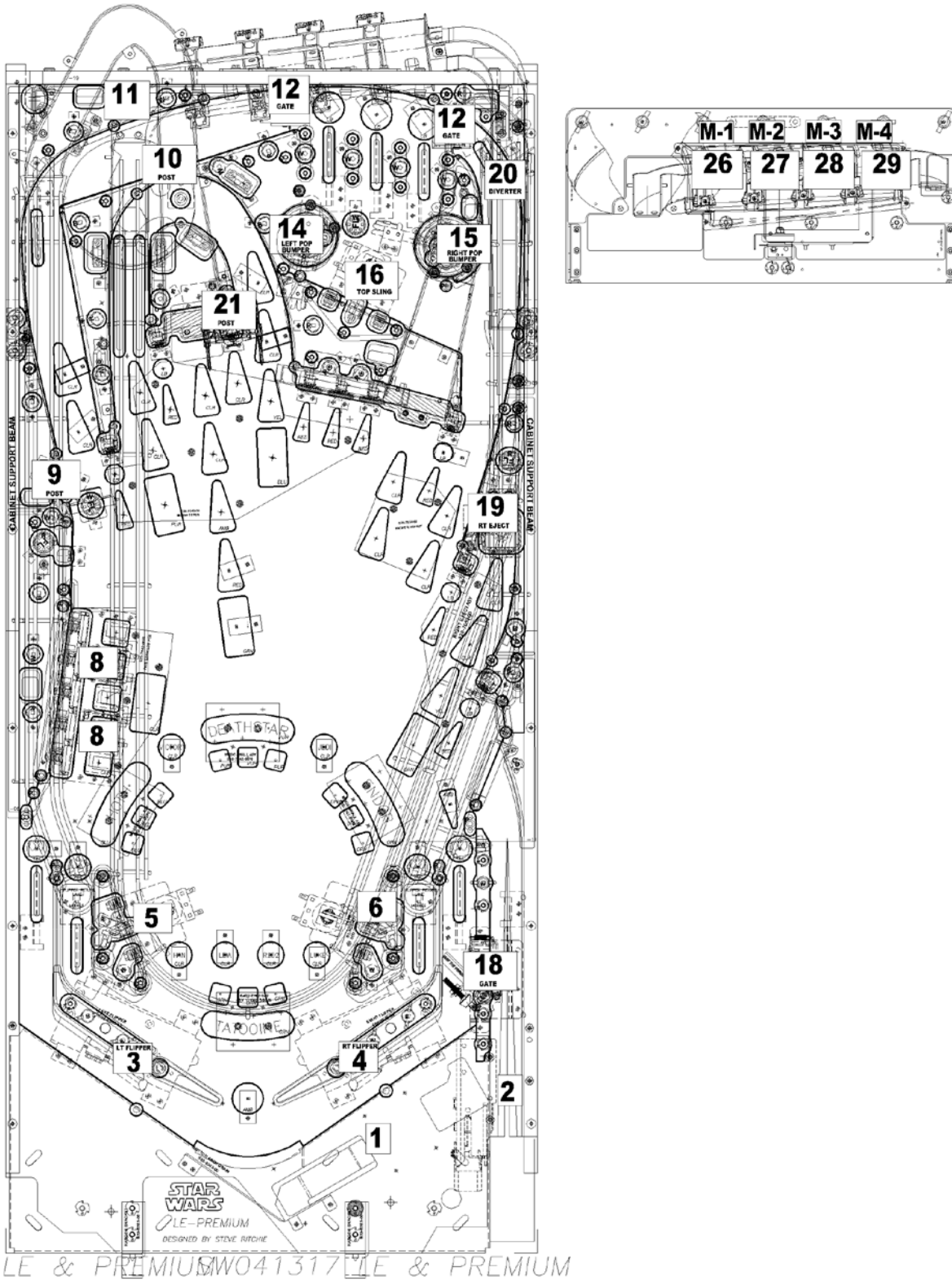

Figure 3.2.1. Playfield driver locations (top view).

### 3.3 SWITCH REFERENCE

ID	Name	Node	Node Ext	Conn.	Input Pin	Input Wire	GND Pin	Ground Wire	Location	Type	Address	Part Number
1	Left Outlane	8	-	CN11	4	LGN RED	11-12	BLK ORG	Playfield	Rollover	8-SW-17	500-9935-04
2	Left Return Lane	8	-	CN11	5	LGN ORG	11-12	BLK ORG	Playfield	Rollover	8-SW-18	500-9935-03
3												
4												
5	Right Return Lane	8	-	CN11	6	LGN YEL	11-12	BLK ORG	Playfield	Rollover	8-SW-19	500-9935-04
6	Right Outlane	8	-	CN11	7	LGN BLU	11-12	BLK ORG	Playfield	Rollover	8-SW-20	500-9935-04
7	Left Slingshot	8	-	CN10	4	GRY BLU	8	BLK GRN	Playfield	Leaf	8-SW-30	180-5231-00
8	Right Slingshot	8	-	CN10	3	GRY VIO	8	BLK GRN	Playfield	Leaf	8-SW-29	180-5231-00
9	Left Flipper Button	8	-	CN9	4	GRY BRN	7	BLK GRN	Cabinet	Leaf	8-SW-25	180-5160-01
10	Right Flipper Button	8	-	CN9	3	GRY RED	7	BLK GRN	Cabinet	Leaf	8-SW-24	180-5160-01
11	Left Flipper EOS	8	-	CN10	6	GRY YEL	9	BLK GRN	Playfield	Leaf	8-SW-16	180-5149-00
12	Right Flipper EOS	8	-	CN10	5	GRY GRN	9	BLK GRN	Playfield	Leaf	8-SW-31	180-5149-00
13												
14												
15	Trough 6	8	8a	CN14	-		-		Playfield	Opto	8-SW-32	520-5344-00 tx 520-7001-00 rx
16	Trough 5	8	8a	CN14	-		-		Playfield	Opto	8-SW-33	520-5344-00 tx 520-7001-00 rx
17	Trough 4	8	8a	CN14	-		-		Playfield	Opto	8-SW-34	520-5344-00 tx 520-7001-00 rx
18	Trough 3	8	8a	CN14	-		-		Playfield	Opto	8-SW-35	520-5344-00 tx 520-7001-00 rx
19	Trough 2	8	8a	CN14	-		-		Playfield	Opto	8-SW-36	520-5344-00 tx 520-7001-00 rx
20	Trough 1	8	8a	CN14	-		-		Playfield	Opto	8-SW-37	520-5344-00 tx 520-7001-00 rx
21	Trough Jam	8	8a	CN14	-		-		Playfield	Opto	8-SW-38	520-5344-00 tx 520-7001-00 rx
22	Shooter Lane	8	-	CN10	2	GRY WHT	7	BLK GRN	Playfield	Rollover	8-SW-28	180-5157-01
23	Skill Shot	9	-	CN12	7	PNK GRN	10	BLK VIO	Playfield	Rollover	9-SW-13	500-9935-04
24	(F)ORCE Drop Target	9	-	CN13	2	WHT BRN	10	BLK GRY	Playfield	Opto	9-SW-0	520-5252-13
25	F(O)RCE Drop Target	9	-	CN13	3	WHT RED	10	BLK GRY	Playfield	Opto	9-SW-1	520-5252-13
26	FO(R)CE Drop Target	9	-	CN13	4	WHT ORG	10	BLK GRY	Playfield	Opto	9-SW-2	520-5252-13
27	FOR(C)E Drop Target	9	-	CN13	5	WHT YEL	10	BLK GRY	Playfield	Opto	9-SW-3	520-5252-12
28	FORC(E) Drop Target	9	-	CN13	6	WHT GRN	10	BLK GRY	Playfield	Opto	9-SW-4	520-5252-12
29	Spinner	8	-	CN11	2	LGN BLK	11-12	BLK ORG	Playfield	Micro	8-SW-26	180-5010-04
30												
31												
32	Left Orbit	8	-	CN11	8	LGN VIO	11-12	BLK ORG	Playfield	Micro	8-SW-21	500-9935-04
33	Left Ramp Opto	8	-	CN11	9	LGN GRY	11-12	BLK ORG	Playfield	Opto	8-SW-22	515-0215-00 tx 515-0215-01 rx
34												
35	Inner Loop Left	9	-	CN11	9	TAN BLU	11-12	BLK BLU	Playfield	Opto	9-SW-22	515-0215-00 tx 515-0215-01 rx
36	Inner Loop Right	9	-	CN11	10	TAN VIO	11-12	BLK BLU	Playfield	Opto	9-SW-23	515-0215-00 tx 515-0215-01 rx
37												
38	Mini Target 1	8	-	CN11	3	LGN BRN	11-12	BLK ORG	Playfield	Leaf, Target	8-SW-27	515-9785-00-00
39	Mini Target 2	9	-	CN12	2	PNK BLK	10	BLK VIO	Playfield	Leaf, Target	9-SW-8	515-9785-00-00
40	Mini Target 3	9	-	CN12	3	PNK BRN	10	BLK VIO	Playfield	Leaf, Target	9-SW-9	515-9785-00-00

Continued on next page...



## SWITCH REFERENCE CONTINUED

ID	Name	Node	Node Ext	Conn.	Input Pin	Input Wire	GND Pin	Ground Wire	Location	Type	Address	Part Number
41	Mini Target 4	9	-	CN12	4	PNK RED	10	BLK VIO	Playfield	Leaf, Target	9-SW-10	515-9785-00-00
42	Mini Target 5	9	-	CN12	5	PNK ORG	10	BLK VIO	Playfield	Leaf, Target	9-SW-11	515-9785-00-00
43	Mini Target 6	9	-	CN12	6	PNK YEL	10	BLK VIO	Playfield	Leaf, Target	9-SW-12	515-9785-00-00
44	Right Eject	8	-	CN11	10	LGN WHT	11-12	BLK ORG	Playfield	Micro	8-SW-23	180-5209-00
45												
46	3 Bank Target Left	9	-	CN11	4	TAN BLK	11-12	BLK BLU	Playfield	Leaf, Target	9-SW-17	515-9783-00-00
47	3 Bank Target Center	9	-	CN11	5	TAN RED	11-12	BLK BLU	Playfield	Leaf, Target	9-SW-18	515-9783-00-00
48	3 Bank Target Right	9	-	CN11	6	TAN ORG	11-12	BLK BLU	Playfield	Leaf, Target	9-SW-19	515-9783-00-00
49	10 Pt	9	-	CN11	7	TAN YEL	11-12	BLK BLU	Playfield	Leaf	9-SW-20	180-5231-00
50												
51	Top Lane Left	9	-	CN9	3	PNK VIO	7-8	BLK YEL	Playfield	Micro	9-SW-24	500-9935-03
52	Top Lane Center	9	-	CN9	4	PNK GRY	7-8	BLK YEL	Playfield	Micro	9-SW-25	500-9935-03
53	Top Lane Right	9	-	CN9	5	PNK WHT	7-8	BLK YEL	Playfield	Micro	9-SW-26	500-9935-04
54	Left Pop Bumper	9	-	CN10	2	GRY BLK	7-9	BLK YEL	Playfield	Leaf	9-SW-28	180-5232-00
55	Right Pop Bumper	9	-	CN10	3	GRY BRN	7-9	BLK YEL	Playfield	Leaf	9-SW-29	180-5232-00
56	Top Sling	9	-	CN10	4	GRY RED	7-9	BLK YEL	Playfield	Leaf	9-SW-30	180-5231-00
57	Right Ramp	9	-	CN10	5	GRY ORG	7-9	BLK YEL	Playfield	Micro	9-SW-31	180-5087-00
58	Right Orbit	9	-	CN10	6	GRY	7-9	BLK YEL	Playfield	Micro	9-SW-16	500-9935-03
59												
60												
61	Fork Ramp Home	9	-	CN13	7	WHT BLU	10	BLK GRY	Playfield	Micro	9-SW-5	180-5119-02
62	Fork Ramp Mid	9	-	CN13	8	WHT VIO	10	BLK GRY	Playfield	Micro	9-SW-6	180-5119-02
63	Fork Ramp Up	9	-	CN13	9	WHT GRY	10	BLK GRY	Playfield	Micro	9-SW-7	180-5119-02
64	Accelerator Opto 1	11	-	CN15	2	WHT BLU	14	BLK WHT	Backpanel	Opto	11-SW-4	515-0215-00 tx 515-0215-01 rx
65	Accelerator Opto 2	11	-	CN15	3	WHT VIO	14	BLK WHT	Backpanel	Opto	11-SW-5	515-0215-00 tx 515-0215-01 rx
66	Accelerator Opto 3	11	-	CN15	4	WHT GRY	14	BLK WHT	Backpanel	Opto	11-SW-6	515-0215-00 tx 515-0215-01 rx
67	Accelerator Opto 4	11	-	CN15	5	WHT	14	BLK WHT	Backpanel	Opto	11-SW-7	515-0215-00 tx 515-0215-01 rx
68												
69												
70	Lockdown Button	1	-	CN7	8	TAN WHT	5	BLK WHT	Cabinet	Leaf	1-SW-2	180-5218-00
71												
72												
73	Start Button	1	-	CN6	10	GRY	5	BLK WHT	Cabinet	Micro	1-SW-11	180-5174-00
74	Tournament Start Button	1	-	CN6	9	GRY WHT	5	BLK WHT	Cabinet	Micro	1-SW-12	180-5174-00
75												
76	Left Coin	1	-	CN5	9	PNK BRN	3	BLK	Cabinet	Micro	1-SW-16	
77	Right Coin	1	-	CN5	7	PNK ORG	3	BLK	Cabinet	Micro	1-SW-18	
78	Center Coin	1	-	CN5	8	PNK RED	3	BLK	Cabinet	Micro	1-SW-17	
79	Fourth Coin	1	-	CN5	6		-		Cabinet	-	1-SW-19	
80	Fifth Coin	1	-	CN5	5		-		Cabinet	-	1-SW-20	
81	Tilt Pendulum	1	-	CN6	7	WHT	5	BLK WHT	Cabinet	Plumb Bob	1-SW-14	516-0007-00

Continued on next page...



SWITCH REFERENCE CONTINUED

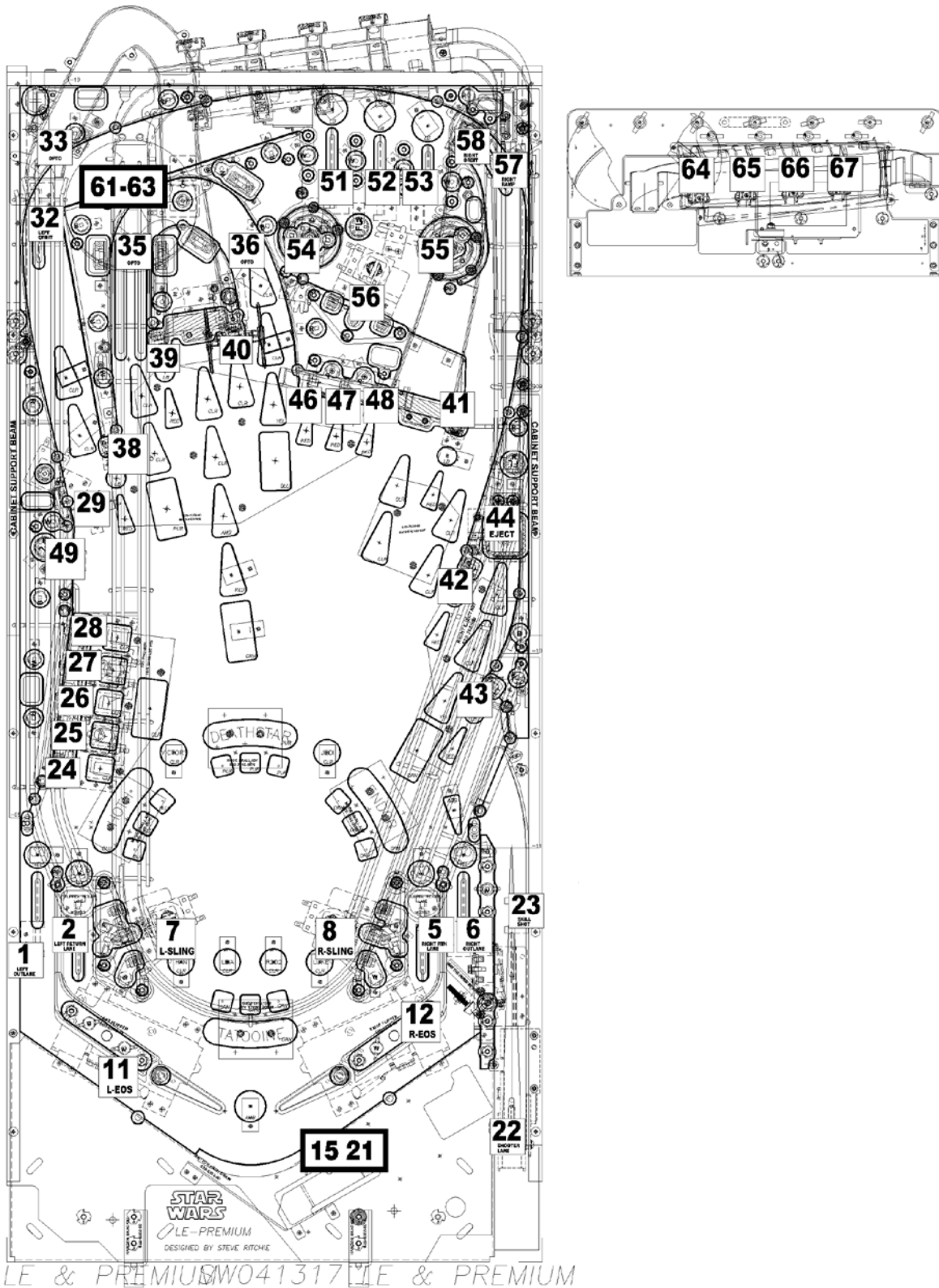

Figure 3.3.1. Playfield switch locations (top view).

Continued on next page...



## SWITCH REFERENCE CONTINUED

ID	Name	Node	Node Ext	Conn.	Input Pin	Input Wire	GND Pin	Ground Wire	Location	Type	Address	Part Number
82	Sixth Coin	1	-	CN9	5		-		Cabinet	-	1-SW-21	
83	Ticket Notch	1	-	CN11	5		-		Cabinet	-	1-SW-8	
84	Slam Tilt	1	-	CN5	4	LGN RED	3	BLK	Cabinet	-	1-SW-22	
85												
86												
87												
88												
89												
C1	DIP 1	0	-	-	-		-		CPU Node		0-SW-0	-
C10	Service Plus	0	-	CN25	3	LGN VIO	6	BLK	Coin Door		0-SW-9	180-5192-02
C11	Service Minus	0	-	CN25	2	LGN BLU	6	BLK	Coin Door		0-SW-10	180-5192-02
C12	Service Back	0	-	CN25	1	LGN BLK	6	BLK	Coin Door		0-SW-11	180-5192-00
C17	Headphone Detect	0	-	-	-	-	-	-	Coin Door		0-SW-16	-
C18	Headphone Kit Cable Detect	0	-	CN3	5	BLK	4	BLK	CPU Node		0-SW-17	-
C19	Volume Encoder 1	0	-	CN3	6	WHT	1	DRAIN	CPU Node		0-SW-18	-
C2	DIP 2	0	-	-	-		-		CPU Node		0-SW-1	-
C20	Volume Encoder 2	0	-	CN3	7	GRN	1	DRAIN	CPU Node		0-SW-19	-
C24	DC Sense	0	-	CN7	4	GRY RED	1	BLK	-		0-SW-23	-
C3	DIP 3	0	-	-	-		-		CPU Node		0-SW-2	-
C4	DIP 4	0	-	-	-		-		CPU Node		0-SW-3	-
C5	DIP 5	0	-	-	-		-		CPU Node		0-SW-4	-
C6	DIP 6	0	-	-	-		-		CPU Node		0-SW-5	-
C7	DIP 7	0	-	-	-		-		CPU Node		0-SW-6	-
C8	DIP 8	0	-	-	-		-		CPU Node		0-SW-7	-
C9	Service Select	0	-	CN25	4	LGN GRY	6	BLK	Coin Door		0-SW-8	180-5192-04

## 3.4 LIGHT REFERENCE

ID	Name	Node	Node Ext.	Conn.	Ret. Pin	Ret. Wire	Src. Pin	Src. Wire	Location	Type	Light Color	Address	Part Number
1	Coin Enable	1	-	CN8	6	BLK GRY	2	GRY RED	Coin Door	Digital Out		1-LP-0	
2	Start Button	1	-	CN6	3	YEL BRN	1	RED	Cabinet	Feature	White	1-LP-2	112-5033-08
3	Tournament Start	1	-	CN6	2	YEL RED	1	RED	Cabinet	Feature	White	1-LP-3	112-5033-08
4	Lockdown Button-R	1	-	CN7	2	RED WHT	1	RED	Cabinet	Feature	RGB	1-LP-5	520-5333-00
5	Lockdown Button-G	1	-	CN7	3	GRN WHT	1	RED	Cabinet	Feature	RGB	1-LP-4	520-5333-00
6	Lockdown Button-B	1	-	CN7	4	BLU WHT	1	RED	Cabinet	Feature	RGB	1-LP-7	520-5333-00
7													
8													
9													
10													
11	LEFT OUTLANE	8	e	CN2	5	BLU VIO	1	RED	Playfield	Feature	White	8-LP-36	520-5307-00
12	LEFT RETURNLANE	8	e	CN2	4	BLU GRY	1	RED	Playfield	Feature	White	8-LP-37	520-5307-00
13	RIGHT RETURNLANE	8	c	CN2	2	GRN WHT	1	RED	Playfield	Feature	White	8-LP-23	520-5307-00
14	RIGHT OUTLANE	8	c	CN2	3	GRN GRY	1	RED	Playfield	Feature	White	8-LP-22	520-5307-00
15	SKILL SHOT	8	c	CN2	4	GRN VIO	1	RED	Playfield	Feature	White	8-LP-21	520-5307-00
16													
17	HOTH MINI	8	e	-	LED1&2	-	-	-	Playfield	Feature	White	8-LP-32	520-7042-00
18	HOTH ONE	8	e	-	LED3	-	-	-	Playfield	Feature	White	8-LP-33	520-7042-00
19	HOTH TWO	8	e	-	LED4	-	-	-	Playfield	Feature	White	8-LP-34	520-7042-00
20	HOTH THREE	8	e	-	LED5	-	-	-	Playfield	Feature	White	8-LP-35	520-7042-00
21													
22	DEATHSTAR MINI	8	d	-	LED1&2	-	-	-	Playfield	Feature	White	8-LP-24	520-7042-00
23	DEATHSTAR ONE	8	d	-	LED3	-	-	-	Playfield	Feature	White	8-LP-25	520-7042-00
24	DEATHSTAR TWO	8	d	-	LED4	-	-	-	Playfield	Feature	White	8-LP-26	520-7042-00
25	DEATHSTAR THREE	8	d	-	LED5	-	-	-	Playfield	Feature	White	8-LP-27	520-7042-00
26													
27	TATOOINE MINI	8	c	-	LED1&2	-	-	-	Playfield	Feature	White	8-LP-16	520-7042-00
28	TATOOINE ONE	8	c	-	LED3	-	-	-	Playfield	Feature	White	8-LP-17	520-7042-00
29	TATOOINE TWO	8	c	-	LED4	-	-	-	Playfield	Feature	White	8-LP-18	520-7042-00
30	TATOOINE THREE	8	c	-	LED5	-	-	-	Playfield	Feature	White	8-LP-19	520-7042-00
31													
32	ENDOR MINI	8	b	-	LED1&2	-	-	-	Playfield	Feature	White	8-LP-8	520-7042-00
33	ENDOR ONE	8	b	-	LED5	-	-	-	Playfield	Feature	White	8-LP-11	520-7042-00
34	ENDOR TWO	8	b	-	LED4	-	-	-	Playfield	Feature	White	8-LP-10	520-7042-00
35	ENDOR THREE	8	b	-	LED3	-	-	-	Playfield	Feature	White	8-LP-9	520-7042-00
36													
37	JEDI	8	e	CN2	3	BLU WHT	1	RED	Playfield	Feature	White	8-LP-38	520-5307-00
38	VICTORY MULTI-BALL	8	c	CN2	5	GRN RED	1	RED	Playfield	Feature	White	8-LP-20	520-5307-00
39													
40	LUKE	8	b	CN2	5	BRN BLU	1	RED	Playfield	Feature	White	8-LP-12	520-5307-00
41	R2D2	8	b	CN2	4	BRN VIO	1	RED	Playfield	Feature	White	8-LP-13	520-5307-00
42	LEIA	8	b	CN2	3	BRN GRY	1	RED	Playfield	Feature	White	8-LP-14	520-5307-00
43	HAN	8	b	CN2	2	BRN WHT	1	RED	Playfield	Feature	White	8-LP-15	520-5307-00
44													
45	SHOOT AGAIN	8	-	CN14	6	BLU RED	8	YEL	Playfield	Feature	White	8-LP-3	520-5307-00
46													
47													
48													
49													
50	(F)ORCE	8	f	-	LED7	-	-	-	Playfield	Feature	White	8-LP-46	520-7043-00
51	F(O)RCE	8	f	-	LED6	-	-	-	Playfield	Feature	White	8-LP-45	520-7043-00

Continued on next page...

## LIGHT REFERENCE CONTINUED

ID	Name	Node	Node Ext.	Conn.	Ret. Pin	Ret. Wire	Src. Pin	Src. Wire	Location	Type	Light Color	Address	Part Number
52	FO(R)CE	8	f	-	LED5	-	-	-	Playfield	Feature	White	8-LP-44	520-7043-00
53	FOR(C)E	8	f	-	LED4	-	-	-	Playfield	Feature	White	8-LP-43	520-7043-00
54	FORC(E)	8	f	-	LED3	-	-	-	Playfield	Feature	White	8-LP-42	520-7043-00
55	LIGHT SABER DUEL	8	f	-	LED8	-	-	-	Playfield	Feature	White	8-LP-47	520-7043-00
56													
57													
58													
59													
60	LEFT ORBIT ARROW-R	10	a	CN3	10	RED ORG	1/2	RED	Playfield	Feature	RGB	10-LP-8	520-5333-00
61	LEFT ORBIT ARROW-G	10	a	CN3	9	GRN ORG	1/2	RED	Playfield	Feature	RGB	10-LP-9	520-5333-00
62	LEFT ORBIT ARROW-B	10	a	CN3	8	BLU ORG	1/2	RED	Playfield	Feature	RGB	10-LP-10	520-5333-00
63	LEFT ORBIT X-R	10	a	CN3	7	RED YEL	1/2	RED	Playfield	Feature	RGB	10-LP-11	520-5333-00
64	LEFT ORBIT X-G	10	a	CN3	6	GRN YEL	1/2	RED	Playfield	Feature	RGB	10-LP-12	520-5333-00
65	LEFT ORBIT X-B	10	a	CN3	5	BLU YEL	1/2	RED	Playfield	Feature	RGB	10-LP-13	520-5333-00
66													
67	INNER LOOP LEFT ARROW-R	10	a	-	LED18	-	-	-	Playfield	Feature	RGB	10-LP-19	520-7052-00
68	INNER LOOP LEFT ARROW-G	10	a	-	LED18	-	-	-	Playfield	Feature	RGB	10-LP-20	520-7052-00
69	INNER LOOP LEFT ARROW-B	10	a	-	LED18	-	-	-	Playfield	Feature	RGB	10-LP-21	520-7052-00
70	INNER LOOP LEFT X-R	10	a	-	LED2	-	-	-	Playfield	Feature	RGB	10-LP-1	520-7052-00
71	INNER LOOP LEFT X-G	10	a	-	LED2	-	-	-	Playfield	Feature	RGB	10-LP-2	520-7052-00
72	INNER LOOP LEFT X-B	10	a	-	LED2	-	-	-	Playfield	Feature	RGB	10-LP-3	520-7052-00
73	DEATH STAR	10	a	-	LED1	-	-	-	Playfield	Feature	White	10-LP-0	520-7052-00
74													
75	LEFT RAMP ARROW-R	10	a	-	LED30	-	-	-	Playfield	Feature	RGB	10-LP-37	520-7052-00
76	LEFT RAMP ARROW-G	10	a	-	LED30	-	-	-	Playfield	Feature	RGB	10-LP-38	520-7052-00
77	LEFT RAMP ARROW-B	10	a	-	LED30	-	-	-	Playfield	Feature	RGB	10-LP-39	520-7052-00
78	LEFT RAMP X-R	10	a	-	LED19	-	-	-	Playfield	Feature	RGB	10-LP-22	520-7052-00
79	LEFT RAMP X-G	10	a	-	LED19	-	-	-	Playfield	Feature	RGB	10-LP-23	520-7052-00
80	LEFT RAMP X-B	10	a	-	LED19	-	-	-	Playfield	Feature	RGB	10-LP-24	520-7052-00
81	EXTRA BALL	10	a	-	LED15	-	-	-	Playfield	Feature	White	10-LP-16	520-7052-00
82	SUPER JACKPOT	8	f	CN1	4	ORG BLU	1	RED	Playfield	Feature	White	8-LP-40	520-5307-00
83	ENDOR	8	f	CN1	3	ORG VIO	1	RED	Playfield	Feature	White	8-LP-41	520-5307-00
84													
85	INNER LOOP RIGHT ARROW-R	10	a	CN4	7	RED BRN	1	RED		Feature	RGB	10-LP-26	520-5333-00
86	INNER LOOP RIGHT ARROW-G	10	a	CN4	6	GRN BRN	1	RED		Feature	RGB	10-LP-27	520-5333-00
87	INNER LOOP RIGHT ARROW-B	10	a	CN4	5	BLU BRN	1	RED		Feature	RGB	10-LP-28	520-5333-00
88	INNER LOOP RIGHT X-R	10	a	CN4	4	RED VIO	1	RED		Feature	RGB	10-LP-29	520-5333-00
89	INNER LOOP RIGHT X-G	10	a	CN4	3	GRN VIO	1	RED		Feature	RGB	10-LP-30	520-5333-00
90	INNER LOOP RIGHT X-B	10	a	CN4	2	BLU VIO	1	RED		Feature	RGB	10-LP-31	520-5333-00
91	VIDEO MODE	10	a	-	LED20	-	-	-	Playfield	Feature	White	10-LP-25	520-7052-00
92	HOTH	10	a	-	LED27	-	-	-	Playfield	Feature	White	10-LP-32	520-7052-00
93													
94	RIGHT RAMP ARROW-R	9	b	-	LED4	-	-	-	Playfield	Feature	RGB	9-LP-29	520-7054-00
95	RIGHT RAMP ARROW-G	9	b	-	LED4	-	-	-	Playfield	Feature	RGB	9-LP-30	520-7054-00
96	RIGHT RAMP ARROW-B	9	b	-	LED4	-	-	-	Playfield	Feature	RGB	9-LP-31	520-7054-00
97	RIGHT RAMP X-R	9	b	-	LED8	-	-	-	Playfield	Feature	RGB	9-LP-37	520-7054-00

Continued on next page...



LIGHT REFERENCE CONTINUED

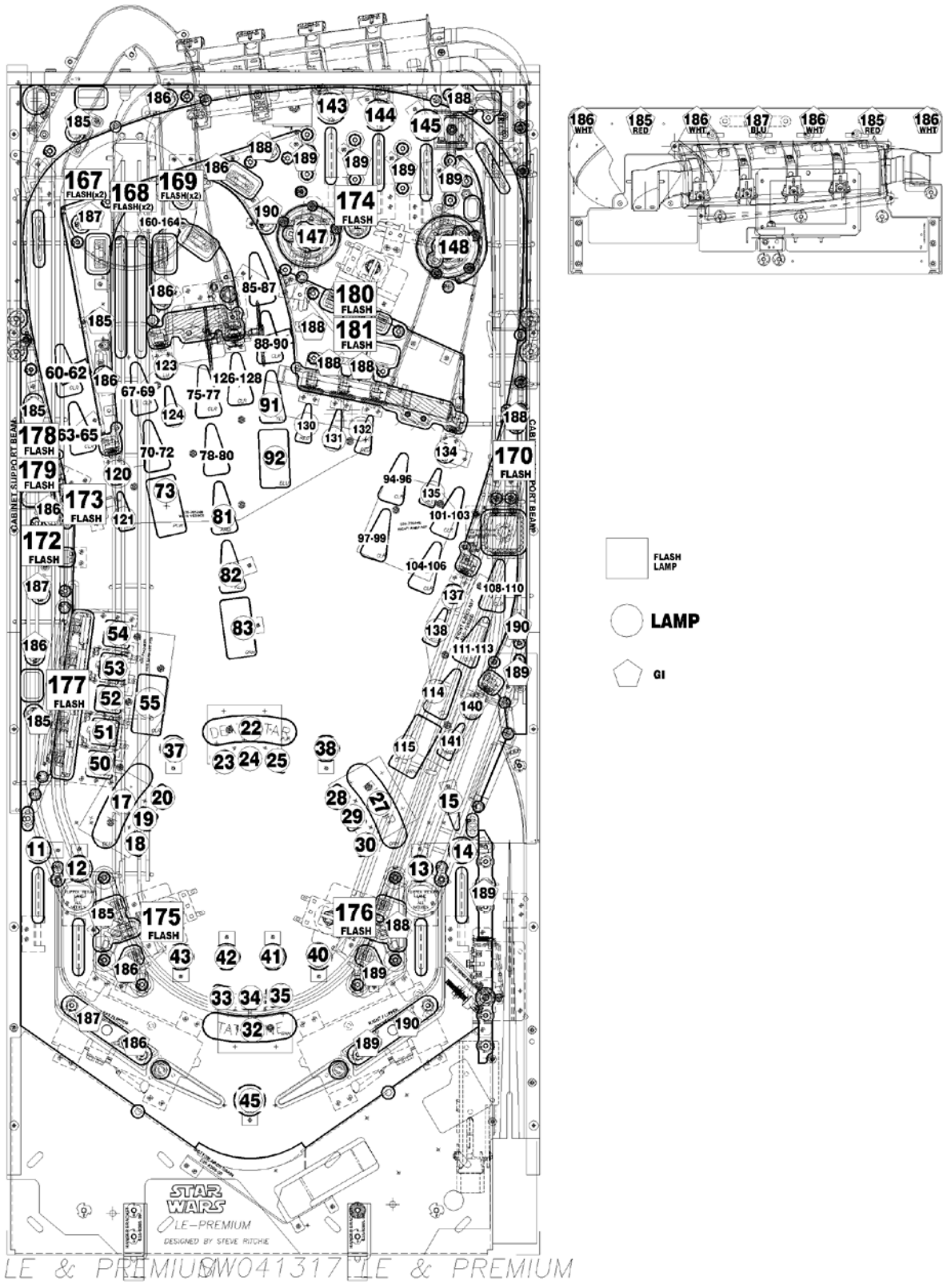

Figure 3.4.1. Playfield light locations (top view).

Continued on next page...



## LIGHT REFERENCE CONTINUED

ID	Name	Node	Node Ext.	Conn.	Ret. Pin	Ret. Wire	Src. Pin	Src. Wire	Location	Type	Light Color	Address	Part Number
98	RIGHT RAMP X-G	9	b	-	LED8	-	-	-	Playfield	Feature	RGB	9-LP-38	520-7054-00
99	RIGHT RAMP X-B	9	b	-	LED8	-	-	-	Playfield	Feature	RGB	9-LP-39	520-7054-00
100													
101	RIGHT ORBIT ARROW-R	9	b	-	LED2	-	-	-	Playfield	Feature	RGB	9-LP-25	520-7054-00
102	RIGHT ORBIT ARROW-G	9	b	-	LED2	-	-	-	Playfield	Feature	RGB	9-LP-26	520-7054-00
103	RIGHT ORBIT ARROW-B	9	b	-	LED2	-	-	-	Playfield	Feature	RGB	9-LP-27	520-7054-00
104	RIGHT ORBIT X-R	9	b	-	LED7	-	-	-	Playfield	Feature	RGB	9-LP-34	520-7054-00
105	RIGHT ORBIT X-G	9	b	-	LED7	-	-	-	Playfield	Feature	RGB	9-LP-35	520-7054-00
106	RIGHT ORBIT X-B	9	b	-	LED7	-	-	-	Playfield	Feature	RGB	9-LP-36	520-7054-00
107													
108	RIGHT EJECT ARROW-R	9	a	-	LED2	-	-	-	Playfield	Feature	RGB	9-LP-9	520-7053-00
109	RIGHT EJECT ARROW-G	9	a	-	LED2	-	-	-	Playfield	Feature	RGB	9-LP-10	520-7053-00
110	RIGHT EJECT ARROW-B	9	a	-	LED2	-	-	-	Playfield	Feature	RGB	9-LP-11	520-7053-00
111	RIGHT EJECT X-R	9	a	-	LED4	-	-	-	Playfield	Feature	RGB	9-LP-13	520-7053-00
112	RIGHT EJECT X-G	9	a	-	LED4	-	-	-	Playfield	Feature	RGB	9-LP-14	520-7053-00
113	RIGHT EJECT X-B	9	a	-	LED4	-	-	-	Playfield	Feature	RGB	9-LP-15	520-7053-00
114	MYSTERY	9	a	-	LED7	-	-	-	Playfield	Feature	White	9-LP-18	520-7053-00
115	TATOOINE	9	a	-	LED6	-	-	-	Playfield	Feature	White	9-LP-17	520-7053-00
116													
117													
118													
119													
120	MINI 1	10	a	-	LED3	-	-	-	Playfield	Feature	White	10-LP-4	520-7052-00
121	XWING 1	10	a	-	LED4	-	-	-	Playfield	Feature	White	10-LP-5	520-7052-00
122													
123	MINI 2	10	a	-	LED17	-	-	-	Playfield	Feature	White	10-LP-18	520-7052-00
124	XWING 2	10	a	-	LED16	-	-	-	Playfield	Feature	White	10-LP-17	520-7052-00
125													
126	XWING 3-R	10	a	-	LED29	-	-	-	Playfield	Feature	RGB	10-LP-34	520-7052-00
127	XWING 3-G	10	a	-	LED29	-	-	-	Playfield	Feature	RGB	10-LP-35	520-7052-00
128	XWING 3-B	10	a	-	LED29	-	-	-	Playfield	Feature	RGB	10-LP-36	520-7052-00
129													
130	XWING 4	10	a	-	LED28	-	-	-	Playfield	Feature	White	10-LP-33	520-7052-00
131	XWING 5	10	a	-	LED32	-	-	-	Playfield	Feature	White	10-LP-45	520-7052-00
132	XWING 6	10	a	-	LED31	-	-	-	Playfield	Feature	White	10-LP-44	520-7052-00
133													
134	MINI 3	9	b	CN2	3	ORG YEL	1	RED	Playfield	Feature	White	9-LP-24	520-5307-00
135	XWING 7	9	b	-	LED3	-	-	-	Playfield	Feature	White	9-LP-28	520-7054-00
136													
137	MINI 4	9	a	-	LED3	-	-	-	Playfield	Feature	White	9-LP-12	520-7053-00
138	XWING 8	9	a	-	LED1	-	-	-	Playfield	Feature	White	9-LP-8	520-7053-00
139													
140	MINI 5	9	a	-	LED5	-	-	-	Playfield	Feature	White	9-LP-16	520-7053-00
141	XWING 9	9	a	-	LED8	-	-	-	Playfield	Feature	White	9-LP-19	520-7053-00
142													
143	TOPLANE LEFT	10	a	CN5	10	ORG BLK	1/2/3	RED	Playfield	Feature	White	10-LP-46	520-5307-00
144	TOPLANE CENTER	10	a	CN5	9	ORG BRN	1/2/3	RED	Playfield	Feature	White	10-LP-47	520-5307-00
145	TOPLANE RIGHT	10	a	CN5	8	ORG RED	1/2/3	RED	Playfield	Feature	White	10-LP-48	520-5307-00

Continued on next page...



## LIGHT REFERENCE CONTINUED

ID	Name	Node	Node Ext.	Conn.	Ret. Pin	Ret. Wire	Src. Pin	Src. Wire	Location	Type	Light Color	Address	Part Number
146													
147	LEFT POP BUMPER	10	a	CN5	7	BRN BLK	1/2/3	RED	Playfield	Feature	White	10-LP-49	520-6971-01
148	RIGHT POP BUMPER	10	a	CN5	6	BRN	1/2/3	RED	Playfield	Feature	White	10-LP-50	520-6971-01
149													
150													
151													
152													
153													
154													
155													
156													
157													
158													
159													
160	DEATH STAR LASER 1	9	c	CN2	7	BRN BLK	8/9	RED	Playfield	Feature	Green	9-LP-40	520-7041-00
161	DEATH STAR LASER 2	9	c	CN2	6	BRN RED	8/9	RED	Playfield	Feature	Green	9-LP-41	520-7041-00
162	DEATH STAR LASER 3	9	c	CN2	5	BRN ORG	8/9	RED	Playfield	Feature	Green	9-LP-42	520-7041-00
163	DEATH STAR LASER 4	9	c	CN2	4	BRN YEL	8/9	RED	Playfield	Feature	Green	9-LP-43	520-7041-00
164	DEATH STAR LASER CENTER	9	c	CN2	3	BRN GRN	8/9	RED	Playfield	Feature	Green	9-LP-44	520-7041-00
165													
166													
167	DEATH STAR LEFT FL(x2)	9	c	CN1	9	RED YEL	10/11/12	RED	Playfield	Flash	White	9-LP-47	520-7000-00
168	DEATH STAR CENTER FL(x2)	9	c	CN1	8	GRN YEL	10/11/12	RED	Playfield	Flash	White	9-LP-48	520-7000-00
169	DEATH STAR RIGHT FL(x2)	9	c	CN1	7	BLU YEL	10/11/12	RED	Playfield	Flash	White	9-LP-49	520-7000-00
170	RIGHT EJECT	9	b	CN2	4	ORG GRN	1	RED	Playfield	Flash	Red	9-LP-32	113-5045-02
171													
172	LEFT SIDE FL	10	a	CN3	3	BRN GRN	1/2	RED	Playfield	Flash	Red	10-LP-15	113-5045-02
173	SPINNER FL	10	a	CN3	4	BRN YEL	1/2	RED	Playfield	Flash	White	10-LP-14	113-5045-08
174	POPS FL	10	a	CN5	5	BRN RED	1/2/3	RED	Playfield	Flash	White	10-LP-51	113-5045-08
175	LEFT SLING FL	8	-	CN14	5	BLU ORG	7/8	YEL	Playfield	Flash	White	8-LP-4	113-5032-08
176	RIGHT SLING FL	8	-	CN14	4	BLU YEL	7/8	YEL	Playfield	Flash	White	8-LP-5	113-5032-08
177	Millennium Falcon FL	10	a	CN2	3	ORG	1	RED	Playfield	Flash	White	10-LP-6	520-7000-00
178	Left Death Star	10	a	CN6	7	ORG GRN	1/2/3	RED	Playfield	Flash	White	10-LP-40	113-5032-08
179	Left TIE Fighter	10	a	CN6	8	ORG BLU	1/2/3	RED	Playfield	Flash	White	10-LP-41	113-5032-08
180	Right Death Star	10	a	CN6	9	ORG VIO	1/2/3	RED	Playfield	Flash	White	10-LP-42	113-5032-08
181	Right TIE Fighter	10	a	CN6	10	ORG GRY	1/2/3	RED	Playfield	Flash	White	10-LP-43	113-5032-02
182													
183													
184	Coin Door GI	1	-	CN5	2	YEL	1	YEL-WHT	Coin Door	G.I.	White	1-LP-1	112-5033-08
185	LEFT RED GI	8	-	CN15	5	RED BLK	1	YEL RED	Playfield/ Backpanel	GI	RED	8-LP-0	112-5034-02
186	LEFT WHITE GI	8	-	CN15	6	WHT BLK	2	YEL BLK	Playfield/ Backpanel	GI	WHITE	8-LP-1	112-5034-08
187	LEFT BLUE GI	8	-	CN15	7	BLU BLK	3	YEL BLU	Playfield/ Backpanel	GI	BLUE	8-LP-2	112-5034-05
188	RIGHT RED GI	9	-	CN15	5	RED BLK	1	YEL RED	Playfield	GI	RED	9-LP-0	112-5034-02
189	RIGHT WHITE GI	9	-	CN15	6	WHT BLK	2	YEL BLK	Playfield	GI	WHITE	9-LP-1	112-5034-08
190	RIGHT BLUE GI	9	-	CN15	7	BLU BLK	3	YEL BLU	Playfield	GI	BLUE	9-LP-2	112-5034-05



### 3.5 MOTOR REFERENCE

ID	Name	Node	Node Ext.	Conn.	Ret. Pin	Ret. Wire	Src. Pin	Src. Wire	Location	Type	Light Color	Address	Part Number
1	Motor A Enable	9	d	CN1	-	-	-	-	Playfield	Motor	-	9-LP-56	520-6996-00
2	Motor A Control 1A	9	d	CN1	-	-	-	-	Playfield	Motor	-	9-LP-57	520-6996-00
3	Motor A Control 2A	9	d	CN1	-	-	-	-	Playfield	Motor	-	9-LP-58	520-6996-00
4													
5													
6													
7													
8													
9													
10													

MOTOR A		Coast	Brake	Brake	Dir. 1	Dir. 2
x-LP-0	Enable A	H	L	L	L	L
x-LP-1	Control 1A	H	L	H	L	H
x-LP-2	Control 2A	H	L	H	H	L
			L/Low=Lamp On			
			H/High=Lamp Off			
MOTOR B		Coast	Brake	Brake	Dir. 1	Dir. 2
x-LP-3	Enable B	H	L	L	L	L
x-LP-4	Control 1B	H	L	H	L	H
x-LP-5	Control 2B	H	L	H	H	L
			L/Low=Lamp On			
			H/High=Lamp Off			
x=Node #			L/Low=Lamp On			
			H/High=Lamp Off			

## 4. ELECTRONIC PINOUTS AND SCHEMATICS

### 4.1 SPIKE-2 CPU NODE 0

509-1003-01

#### DIRECT SWITCH MAPPING (CN25)

The coin-door diagnostic switches are connected directly to the CPU node via the Cabinet Node. Note that both the CPU and Cabinet nodes are required for diagnostic switch operation.

ID	Name	Conn.	Input Pin	Input Wire	GND Pin	Ground Wire	Location	Type	Address	Part Number
C1	DIP 1	-	-	-	-	-	CPU Node		0-SW-0	-
C2	DIP 2	-	-	-	-	-	CPU Node		0-SW-1	-
C3	DIP 3	-	-	-	-	-	CPU Node		0-SW-2	-
C4	DIP 4	-	-	-	-	-	CPU Node		0-SW-3	-
C5	DIP 5	-	-	-	-	-	CPU Node		0-SW-4	-
C6	DIP 6	-	-	-	-	-	CPU Node		0-SW-5	-
C7	DIP 7	-	-	-	-	-	CPU Node		0-SW-6	-
C8	DIP 8	-	-	-	-	-	CPU Node		0-SW-7	-
C9	Service Select	CN25	1	LGN-GRY	11	BLK-WHT	Coin Door		0-SW-9	180-5192-04
C10	Service Plus	CN25	2	LGN-VIO	11	BLK-WHT	Coin Door		0-SW-10	180-5192-02
C11	Service Minus	CN25	3	LGN-BLU	11	BLK-WHT	Coin Door		0-SW-11	180-5192-02
C12	Service Back	CN25	4	LGN-BLK	11	BLK-WHT	Coin Door		0-SW-12	180-5192-00

#### CONNECTORS

ID	Connector Type	Description
CN1	5-Pin .156" Header	Backbox 2-channel amplified speaker out
CN2	3-Pin .100" Header	Console Port
CN3	7-Pin .100" Header	Headphone connector
CN4	2-Pin .156"	Cabinet 1-channel amplified speaker out
CN5	6-Pin .100" Header	Line In/Out
CN6	34 Pin 2.00mm Header	LCD display connector
CN7	5-Pin .156" Header	48V supply from main power supply
CN8	6-Pin .100" Header	SPI Serial
CN9	USB	USB connector - for software updates, audit dumps, and expansion modules
CN9	USB	USB connector - for software updates, audit dumps, and expansion modules
CN10	HDMI	HDMI Out
CN11	RJ45	SPIKE node bus - to cabinet node N1
CN12	RJ45	SPIKE node bus - To Topper accessory Kit
CN13	SD CARD	SD Card connector
CN14	5-Pin .100" Header	LCD Backlight
CN15	3-Pin .100" Header	Backbox Light
CN16	4-Pin .100" Header	3.3v / 5v / 12v
CN17	ETHERNET	ETHERNET connector
CN21	SATA Header	SATA connector
CN22	RJ45	SPIKE node bus - to playfield node
CN25	12-Pin .100" Header	Dedicated switch inputs - service, volume switches

#### COMPONENTS

ID	Name
S1	DIP Switches
S2	Reset Switch
SD CARD (CN13)	For system SD card. Note: only to be removed if instructed to by Stern Service.
BT1	BR1225 3V Lithium battery for game clock between power cycles

#### STATUS LEDs

LED ID	Name	Color	Description
48V	+48V Supply In	Red	ON: Main system power is connected, OFF: No 48V system power. Check power supply connections, cables, and fuses.
24V	+24V Audio Power	Red	ON: Audio power supply is good, OFF: Audio power supply off, call tech support.
9V	+9V Node Bus Power	Red	ON: Node bus power supply is good, OFF: Node bus power supply bad, call tech support.
5V		Red	ON: Logic power supply is good. OFF: Logic power supply bad, call tech support.
TxD	Node bus transmit	Red	Node bus transmit activity
RxD	Node bus receive	Red	Node bus receive activity
Status	System status	Red	Constant double blink - game software running
Netstat	Network status	Red	Communication bridge activity



# SPIKE-2 CPU NODE 0 CONTINUED

## AUDIO PINOUTS

ID	Type	Pin	Description	Minimum Impedance	Max Power (RMS)	
CN1	.156" 5-pin Header	1	Speaker Right Ground (-)	4 Ohms	-	
		2	Speaker Right (+)	4 Ohms	20W	
		3	n/c	-	-	
		4	Speaker Left Ground (-)	4 Ohms	-	
CN3	.100" 7-pin Header	5	Speaker Left (+)	4 Ohms	20W	
		1	n/c	-	-	
		2	L-HP	16 Ohms	15 mW	
		3	R-HP	16 Ohms	15 mW	
CN4	.156" 2-pin Header	4	n/c	-	-	
		5	Headphone Detect	-	-	
		6	Headphone vol +	-	-	
		7	Headphone vol -	-	-	
CN5	.100" 6-pin Header	1	Woofer Ground (-)	8 Ohms	-	
		2	Woofer Out (+)	8 Ohms	40W	
CN5	.100" 6-pin Header	3	L-IN	30K Ohms	0.6VRMS	
		4	R-IN	30K Ohms	0.6VRMS	
		5	L-OUT	10K Ohms	1.5V	
		6	R-OUT	10K Ohms	1.5V	

## COUNTRY CODES (DIP S2)

Country	DIP S2							
	1	2	3	4	5	6	7	8
USA	OFF	OFF	OFF	OFF	OFF	OFF	OFF	OFF
Austria	ON	OFF	OFF	OFF	OFF	OFF	OFF	OFF
Australia	ON	OFF	ON	ON	OFF	OFF	OFF	OFF
Belgium	OFF	ON	OFF	OFF	OFF	OFF	OFF	OFF
Canada 1	ON	ON	OFF	OFF	OFF	OFF	OFF	OFF
Canada 2	OFF	ON	OFF	ON	ON	OFF	OFF	OFF
China	OFF	OFF	ON	ON	ON	OFF	OFF	OFF
Croatia	OFF	ON	ON	OFF	ON	OFF	OFF	OFF
Denmark	ON	OFF	OFF	ON	OFF	OFF	OFF	OFF
Finland	ON	OFF	ON	OFF	OFF	OFF	OFF	OFF
France	OFF	ON	ON	OFF	OFF	OFF	OFF	OFF
Germany	ON	ON	ON	OFF	OFF	OFF	OFF	OFF
Greece	ON	ON	ON	ON	OFF	OFF	OFF	OFF
Italy	OFF	OFF	OFF	ON	OFF	OFF	OFF	OFF
Japan	ON	OFF	ON	OFF	ON	OFF	OFF	OFF
Middle East	ON	ON	ON	OFF	ON	OFF	OFF	OFF
Netherlands	OFF	OFF	ON	OFF	OFF	OFF	OFF	OFF
New Zealand	OFF	OFF	OFF	OFF	ON	OFF	OFF	OFF
Norway	OFF	ON	OFF	ON	OFF	OFF	OFF	OFF
Portugal	ON	OFF	OFF	OFF	OFF	ON	OFF	OFF
Russia	ON	OFF	OFF	ON	ON	OFF	OFF	OFF
S. Africa	OFF	OFF	ON	OFF	ON	OFF	OFF	OFF
Spain	OFF	ON	OFF	OFF	ON	OFF	OFF	OFF
Sweden	ON	ON	OFF	ON	OFF	OFF	OFF	OFF
Switzerland	OFF	OFF	ON	ON	OFF	OFF	OFF	OFF
Taiwan	OFF	OFF	OFF	ON	ON	OFF	OFF	OFF
United Kingdom	OFF	ON	ON	ON	OFF	OFF	OFF	OFF

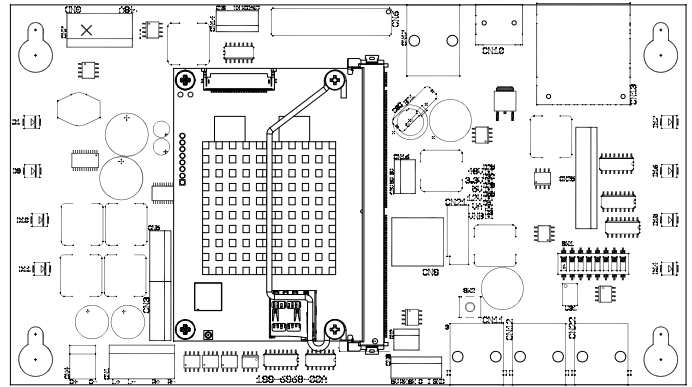

Figure 4.1.1. SPIKE 2 CPU Node connector detail.

## COIN DOOR SERVICE SWITCH WIRING

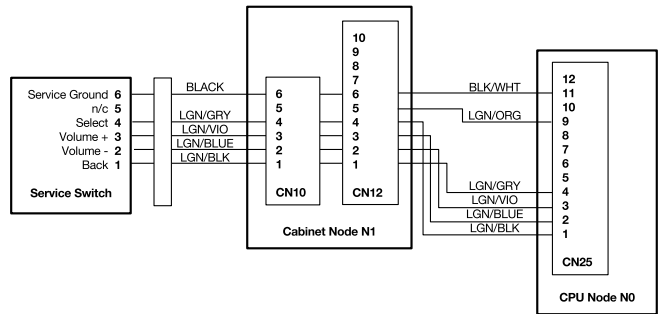
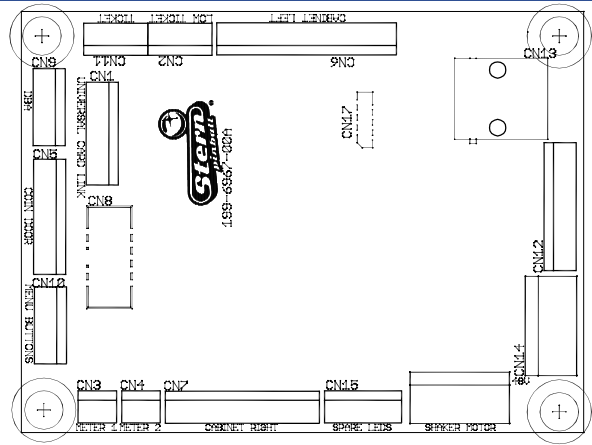

Figure 4.1.2. Service switch wiring. Note that the Cabinet Node must be present and CN10 and CN12 connected for the Coin Door Service Switches to function correctly.

# 4.2 CABINET NODE 1

## 520-6967-72

ID	Type	Pin	Description	Wire Color
CN1	.100" 8-Pin Header Universal Card Link	1	12V	-
		2	Coin 1	-
		3	Meter 1	-
		4	N/C	-
		5	Notch	-
		6	Coin Enable	-
		7	Ticket Enable	-
		8	Ground	-
CN2	.100" 5-Pin Header low ticket	1	Ground	-
		2	Ticket Low sw.	-
		3	Key	-
		4	Ticket Low	-
		5	5V Out	-
CN3	.100" 3-Pin Header Meter 1	1	Meter 12V (+)	RED
		2	Meter (-)	BLK
		3	N/C	-
CN4	.100" 3-Pin Header Meter 2	1	Meter 12V (+)	RED
		2	Meter (-)	BLK
		3	N/C	-
CN5	.100" 9-Pin Header	1	5V Out	YEL/WHT
		2	Coin LED Out	YEL
		3	Ground	BLK
		4	Slam Tilt In	LGN/RED
		5	Coin 5	PNK/GRN*
		6	Coin 4	PNK/YEL*
		7	Coin 3	PNK/ORN*
		8	Coin 2	PNK/RED*
		9	Coin 1	PNK/BRN*
CN6	.100" 14-Pin Header Cabinet Left	1	5V LED Power	RED
		2	Start 2 LED	YEL-RED
		3	Start 1 LED	YEL-BRN
		4	Spare LED	-
		5	Ground	BLK-WHT
		6	Spare Left	-
		7	Tilt Input	WHT
		8	Door Open	-
		9	Start 2 Switch	GRY-WHT
		10	Start 1 Switch	GRY
		11	N/C	-
		12	N/C	-
		13	N/C	-
		14	N/C	-
CN7	.100" 12-Pin Header Cabinet Right	1	5V LED Power	RED
		2	Plunge 2 LED	RED-WHT
		3	Plunge 1 LED	GRN-WHT
		4	Spare LED 2	BLU-WHT
		5	Ground	BLK-WHT
		6	Spare Right In	-
		7	Plunge 2 Switch	-
		8	Plunge 1 Switch	TAN-WHT
		9	N/C	-
		10	N/C	-
		11	N/C	-
		12	N/C	-



CN9	.100" 6-Pin Header Dollar Bill Acceptor	1	Coin Enable/DBA Inhibit (-)	-
		2	Coin Enable/DBA Inhibit (+)	-
		3	Key	Key
		4	DBA 12V	-
		5	Coin 6 / DBA Credit	-
		6	Ground	-
CN10	.100" 6-Pin Header Service Switch In	1	Service Back (To Coin-door)	LGN-BLK
		2	Service Down (To Coin-door)	LGN-BLU
		3	Service Up (To Coin-door)	LGN-VIO
		4	Service Select (To Coin-door)	LGN-GRY
		5	Key	Key
		6	Service Ground (To Coin-door)	BLK
CN11	.100" 5-Pin Header Ticket Dispenser	1	12V	RED
		2	N/C	-
		3	Ticket Dispenser Enable	WHT
		4	Ground	BLK
		5	Ticket Dispenser Notch	BLU
CN12	.100" 10-Pin Header CPU Direct Switches	1	Service Back (To CPU)	LGN-BLK
		2	Service Down (To CPU)	LGN-BLU
		3	Service Up (To CPU)	LGN-VIO
		4	Service Select (To CPU)	LGN-GRY
		5	Power Present	LGN-ORG
		6	Service Ground (To CPU)	BLK-WHT
		7	N/C	-
		8	N/C	-
		9	N/C	-
		10	N/C	-
CN14	.156" 5-Pin Header Power Input	1	Ground	BLK
		2	Key	Key
		3	N/C	-
		4	N/C	-
		5	48VDC In	GRY-YEL
CN15	.100" 6-Pin Header Spare LED's	1	5V LED Power	-
		2	Key	Key
		3	Spare LED 3	-
		4	Spare LED 4	-
		5	Spare LED 5	-
		6	Spare LED 6	-
CN16	.156" 5-Pin Header Shaker Motor	1	Shaker Motor (-)	BLU
		2	Shaker Motor (-)	-
		3	Shaker Motor (+)	-
		4	Key	Key
		5	Shaker Motor (+)	RED
				*Varies by country model



# 4.3 LOWER PLAYFIELD 48V DRIVER PINOUT NODE 8

520-7017-72

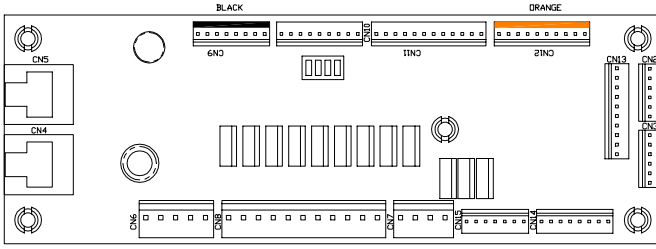

ID	Type	Pin	Description	Wire Color
SW1	Address DIP	-	Node 8 - OFF-OFF-OFF-OFF	-
CN4	RJ45	-	SPIKE Node Bus	Multi
CN5	RJ45	-	SPIKE Node Bus	Multi
CN6	.156" 5-Pin Header Node Power	1	Ground	BLK
		2	Key	Key
		3	N/C	-
		4	N/C	-
		5	48VDC In	GRY
CN7	.156" 4-Pin Header (White)	1	48V Driver Power	GRY-ORG
		2	8-DR-8 Driver Return	YEL-RED
		3	8-DR-6 Driver Return	YEL-BRN
		4	8-DR-7 Driver Return	YEL-BLK
CN8	.156 11-Pin Header (White)	1	48V Driver Power	GRY-ORG
		2	48V Driver Power	GRY-ORG
		3	48V Driver Power	GRY-ORG
		4	48V Driver Power	GRY-ORG
		5	8-DR-0 Driver Return	ORG-GRN
		6	8-DR-5 Driver Return	ORG-YEL
		7	8-DR-1 Driver Return	ORG-GRY
		8	8-DR-8 Driver Return	-
		9	8-DR-4 Driver Return	ORG-WHT
		10	8-DR-2 Driver Return	ORG-VIO
		11	8-DR-3 Driver Return	ORG-BLU
CN9	.100" 8-Pin Header	1	V+	-
		2	V+	-
		3	8-SW-24 Switch	GRY-RED
		4	8-SW-25 Switch	GRY-BRN
		5	8-SW-26 Switch	-
		6	8-SW-27 Switch	-
		7	Ground	BLK-GRN
		8	Ground	-
CN10	.100" 9-Pin Header	1	V+	-
		2	8-SW-28 Switch	GRY-WHT
		3	8-SW-29 Switch	GRY-VIO
		4	8-SW-30 Switch	GRY-BLU
		5	8-SW-31 Switch	GRY-GRN
		6	8-SW-16 Switch	GRY-YEL
		7	Ground	BLK-GRN
		8	Ground	BLK-GRN
		9	Ground	BLK-GRN

CN11	.100" 12-Pin Header	1	V+	RED
		2	8-SW-26 Switch	LGN-BLK
		3	8-SW-27 Switch	LGN-BRN
		4	8-SW-17 Switch	LGN-RED
		5	8-SW-18 Switch	LGN-ORG
		6	8-SW-19 Switch	LGN-YEL
		7	8-SW-20 Switch	LGN-BLU
		8	8-SW-21 Switch	LGN-VIO
		9	8-SW-22 Switch	LGN-GRY
		10	8-SW-23 Switch	LGN-WHT
		11	Ground	BLK-ORG
		12	Ground	BLK-ORG
CN12	.100" 10-Pin Header (Orange)	1	V+	-
		2	8-SW-8 Switch	-
		3	8-SW-9 Switch	-
		4	8-SW-10 Switch	-
		5	8-SW-11 Switch	-
		6	8-SW-12 Switch	-
		7	8-SW-13 Switch	-
		8	8-SW-14 Switch	-
		9	8-SW-15 Switch	-
		10	Ground	-
CN13	.100" 10-Pin Header	1	V+	-
		2	8-SW-0 Switch	-
		3	8-SW-1 Switch	-
		4	8-SW-2 Switch	-
		5	8-SW-3 Switch	-
		6	8-SW-4 Switch	-
		7	8-SW-5 Switch	-
		8	8-SW-6 Switch	-
		9	8-SW-7 Switch	-
		10	Ground	-
CN14	.100" 8-Pin Header	1	Ground	-
		2	8-LP-7 Driver Return	-
		3	8-LP-6 Driver Return	-
		4	8-LP-5 Driver Return	BLU-YEL
		5	8-LP-4 Driver Return	BLU-ORG
		6	8-LP-3 Driver Return	BLU-RED
		7	LED V+	YEL
		8	LED V+	YEL
CN15	.100" 7-Pin Header	1	LED V+	YEL-RED
		2	LED V+	YEL-BLK
		3	LED V+	YEL-BLU
		4	-	-
		5	8-LP-0 GI Return	RED-BLK
		6	8-LP-1 GI Return	WHT-BLK
		7	8-LP-2 GI Return	BLU-BLK
CN2	.100" 6-Pin Header, Node Extension Bus	1	Ground	BLK
		2	DIN	VIO-BLK
		3	DOUT	VIO-BRN
		4	SCK	VIO-RED
		5	RCK	VIO-ORG
		6	V+	RED
CN3	.100" 6-Pin Header, Node Extension Bus	1	Ground	BLK
		2	DIN	VIO-BLK
		3	DOUT	VIO-BRN
		4	SCK	VIO-RED
		5	RCK	VIO-ORG
		6	V+	RED

# 4.4 MID UPPER PLAYFIELD 48V DRIVER PINOUT NODE 9

520-7017-72

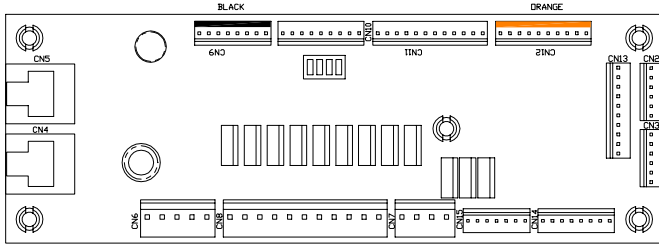

ID	Type	Pin	Description	Wire Color
SW1	Address DIP	-	Node 9 - OFF-OFF-ON-OFF	-
CN4	RJ45	-	SPIKE Node Bus	Multi
CN5	RJ45	-	SPIKE Node Bus	Multi
CN6	.156" 5-Pin Header Node Power	1	Ground	BLK
		2	Key	Key
		3	N/C	-
		4	N/C	-
		5	48VDC In	GRY
CN7	.156" 4-Pin Header (White)	1	48V Driver Power	GRY-BRN
		2	9-DR-8 Driver Return	YEL-WHT
		3	9-DR-6 Driver Return	YEL-VIO
		4	9-DR-7 Driver Return	YEL-GRY
CN8	.156 11-Pin Header (White)	1	48V Driver Power	GRY-BRN
		2	48V Driver Power	GRY-BRN
		3	48V Driver Power	GRY-BRN
		4	48V Driver Power	GRY-BRN
		5	9-DR-0 Driver Return	YEL-BLU
		6	9-DR-5 Driver Return	YEL-GRN
		7	9-DR-1 Driver Return	YEL-ORG
		8	9-DR-8 Driver Return	-
		9	9-DR-4 Driver Return	ORG-RED
		10	9-DR-2 Driver Return	ORG-BLK
		11	9-DR-3 Driver Return	ORG-BRN
CN9	.100" 8-Pin Header	1	V+	-
		2	V+	-
		3	9-SW-24 Switch	PNK-VIO
		4	9-SW-25 Switch	PNK-GRY
		5	9-SW-26 Switch	PNK-WHT
		6	9-SW-27 Switch	-
		7	Ground	-
		8	Ground	BLK-YEL
CN10	.100" 9-Pin Header	1	V+	-
		2	9-SW-28 Switch	GRY-BLK
		3	9-SW-29 Switch	GRY-BRN
		4	9-SW-30 Switch	GRY-RED
		5	9-SW-31 Switch	GRY-ORG
		6	9-SW-16 Switch	GRY
		7	Ground	BLK-YEL
		8	Ground	BLK-YEL
		9	Ground	BLK-YEL

CN11	.100" 12-Pin Header	1	V+	RED
		2	9-SW-26 Switch	-
		3	9-SW-27 Switch	-
		4	9-SW-17 Switch	TAN-BLK
		5	9-SW-18 Switch	TAN-RED
		6	9-SW-19 Switch	TAN-ORG
		7	9-SW-20 Switch	TAN-YEL
		8	9-SW-21 Switch	-
		9	9-SW-22 Switch	TAN-BLU
		10	9-SW-23 Switch	TAN-VIO
		11	Ground	BLK-BLU
		12	Ground	BLK-BLU
CN12	.100" 10-Pin Header (Orange)	1	V+	RED
		2	9-SW-8 Switch	PNK-BLK
		3	9-SW-9 Switch	PNK-BRN
		4	9-SW-10 Switch	PNK-RED
		5	9-SW-11 Switch	PNK-ORG
		6	9-SW-12 Switch	PNK-YEL
		7	9-SW-13 Switch	PNK-GRN
		8	9-SW-14 Switch	-
		9	9-SW-15 Switch	-
		10	Ground	BLK-VIO
CN13	.100" 10-Pin Header	1	V+	RED
		2	9-SW-0 Switch	WHT-BRN
		3	9-SW-1 Switch	WHT-RED
		4	9-SW-2 Switch	WHT-ORG
		5	9-SW-3 Switch	WHT-YEL
		6	9-SW-4 Switch	WHT-GRN
		7	9-SW-5 Switch	WHT-BLU
		8	9-SW-6 Switch	WHT-VIO
		9	9-SW-7 Switch	WHT-GRY
		10	Ground	BLK-GRY
CN14	.100" 8-Pin Header	1	Ground	-
		2	9-LP-7 Driver Return	-
		3	9-LP-6 Driver Return	-
		4	9-LP-5 Driver Return	-
		5	9-LP-4 Driver Return	-
		6	9-LP-3 Driver Return	-
		7	LED V+	-
		8	LED V+	-
CN15	.100" 7-Pin Header	1	LED V+	YEL-RED
		2	LED V+	YEL-BLK
		3	LED V+	YEL-BLU
		4	-	-
		5	9-LP-0 GI Return	RED-BLK
		6	9-LP-1 GI Return	WHT-BLK
		7	9-LP-2 GI Return	BLU-BLK
CN2	.100" 6-Pin Header, Node Extension Bus	1	Ground	-
		2	DIN	-
		3	DOUT	-
		4	SCK	-
		5	RCK	-
		6	V+	-
CN3	.100" 6-Pin Header, Node Extension Bus	1	Ground	BLK
		2	DIN	VIO-BLK
		3	DOUT	VIO-BRN
		4	SCK	VIO-RED
		5	RCK	VIO-ORG
		6	V+	RED



### 4.5 THROUGH SERIAL OPTO RECEIVER EXTENSION 8A 520-7001-00

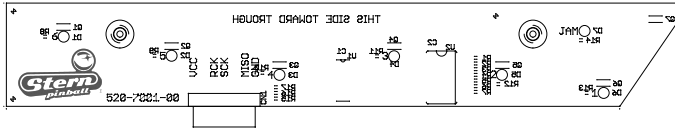

ID	Type	Pin	Description	Wire Color
CN1	.100" 7-Pin Header	1	Ground	BLK
		2	MISO Output Data	VIO-BLK
		3	MOSI Input Data	-
		4	SCK Serial Clock	VIO-RED
		5	RCK Register Clock	VIO-ORG
		6	N/C	-
		7	+5 VDC IN	RED

### 4.6 MODE SMALL LED BOARD 8B 520-7042-00

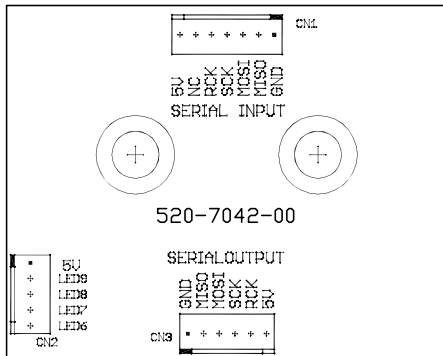

ID	Type	Pin	Description	Wire Color
CN1	.100" 7-Pin Header	1	Ground	BLK
		2	MISO Output Data	VIO-BLK
		3	MOSI Input Data	VIO-BRN
		4	SCK Serial Clock	VIO-RED
		5	RCK Register Clock	VIO-ORG
		6	n/c	-
		7	+5 VDC IN	RED
CN2	.100" 5-Pin Header	1	+5 VDC	RED
		2	LP-9 Light Return	BRN-WHT
		3	LP-8 Light Return	BRN-GRY
		4	LP-7 Light Return	BRN-VIO
		5	LP-6 Light Return	BRN-BLU
CN3	.100" 6-Pin Header	1	Ground	BLK
		2	MISO Output Data	VIO-BLK
		3	MOSI Input Data	VIO-BRN
		4	SCK Serial Clock	VIO-RED
		5	RCK Register Clock	VIO-ORG
		6	V+	RED

### 4.7 MODE SMALL LED BOARD 8C 520-7042-00

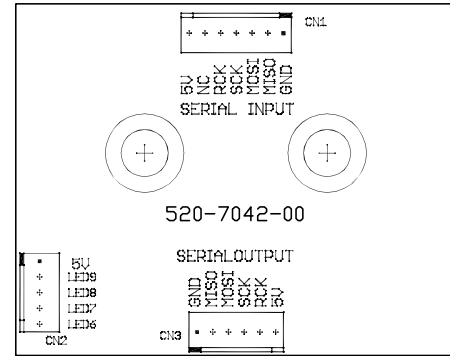

ID	Type	Pin	Description	Wire Color
CN1	.100" 7-Pin Header	1	Ground	BLK
		2	MISO Output Data	VIO-BLK
		3	MOSI Input Data	VIO-BRN
		4	SCK Serial Clock	VIO-RED
		5	RCK Register Clock	VIO-ORG
		6	n/c	-
		7	+5 VDC IN	RED
CN2	.100" 5-Pin Header	1	+5 VDC	RED
		2	LP-9 Light Return	GRN-WHT
		3	LP-8 Light Return	GRN-GRY
		4	LP-7 Light Return	GRN-VIO
		5	LP-6 Light Return	GRN-RED
CN3	.100" 6-Pin Header	1	Ground	BLK
		2	MISO Output Data	VIO-BLK
		3	MOSI Input Data	VIO-BRN
		4	SCK Serial Clock	VIO-RED
		5	RCK Register Clock	VIO-ORG
		6	V+	RED

## 4.8 MODE SMALL LED BOARD 8D 520-7042-00

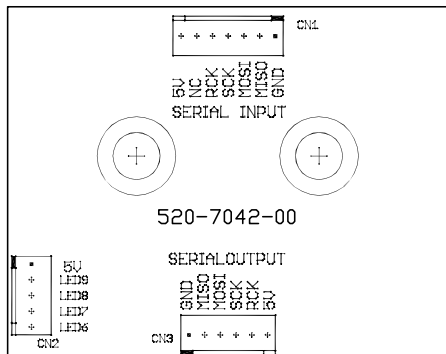

## 4.9 MODE SMALL LED BOARD 8E 520-7042-00

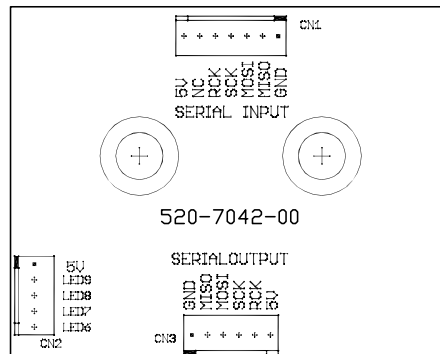

ID	Type	Pin	Description	Wire Color
CN1	.100" 7-Pin Header	1	Ground	BLK
		2	MISO Output Data	VIO-BLK
		3	MOSI Input Data	VIO-BRN
		4	SCK Serial Clock	VIO-RED
		5	RCK Register Clock	VIO-ORG
		6	n/c	-
		7	+5 VDC IN	RED
CN2	.100" 5-Pin Header	1	+5 VDC	-
		2	LP-9 Light Return	-
		3	LP-8 Light Return	-
		4	LP-7 Light Return	-
		5	LP-6 Light Return	-
CN3	.100" 6-Pin Header	1	Ground	BLK
		2	MISO Output Data	VIO-BLK
		3	MOSI Input Data	VIO-BRN
		4	SCK Serial Clock	VIO-RED
		5	RCK Register Clock	VIO-ORG
		6	V+	RED

ID	Type	Pin	Description	Wire Color
CN1	.100" 7-Pin Header	1	Ground	BLK
		2	MISO Output Data	VIO-BLK
		3	MOSI Input Data	VIO-BRN
		4	SCK Serial Clock	VIO-RED
		5	RCK Register Clock	VIO-ORG
		6	n/c	-
		7	+5 VDC IN	RED
CN2	.100" 5-Pin Header	1	+5 VDC	RED
		2	LP-9 Light Return	-
		3	LP-8 Light Return	BLU-WHT
		4	LP-7 Light Return	BLU-GRY
		5	LP-6 Light Return	BLU-VIO
CN3	.100" 6-Pin Header	1	Ground	BLK
		2	MISO Output Data	VIO-BLK
		3	MOSI Input Data	VIO-BRN
		4	SCK Serial Clock	VIO-RED
		5	RCK Register Clock	VIO-ORG
		6	V+	RED

### 4.10 FIVE BANK LED BOARD 8F 520-7043-00

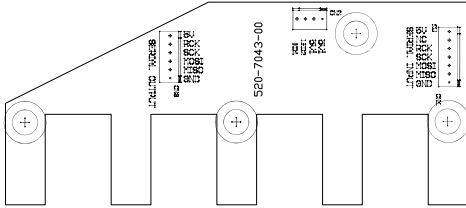

ID	Type	Pin	Description	Wire Color
CN1	.100" 7-Pin Header	1	Ground	BLK
		2	MISO Output Data	VIO-BLK
		3	MOSI Input Data	VIO-BRN
		4	SCK Serial Clock	VIO-RED
		5	RCK Register Clock	VIO-ORG
		6	n/c	-
		7	+5 VDC IN	RED
CN2	.100" 4-Pin Header	1	+5 VDC	RED
		2	+5 VDC	RED
		3	LP-2 Light Return	ORG-VIO
		4	LP-1 Light Return	ORG-BLU
CN3	.100" 6-Pin Header	1	Ground	BLK
		2	MISO Output Data	VIO-BLK
		3	MOSI Input Data	VIO-BRN
		4	SCK Serial Clock	VIO-RED
		5	RCK Register Clock	VIO-ORG
		6	V+	RED

### 4.11 RIGHT EJECT LED BOARD 9A 520-7053-00

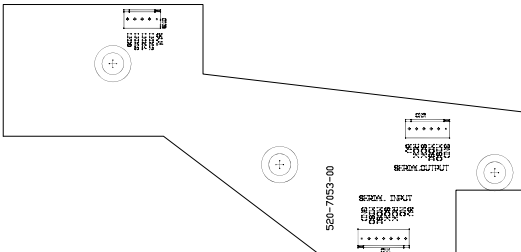

ID	Type	Pin	Description	Wire Color
CN1	.100" 7-Pin Header	1	Ground	BLK
		2	MISO Output Data	VIO-BLK
		3	MOSI Input Data	VIO-BRN
		4	SCK Serial Clock	VIO-RED
		5	RCK Register Clock	VIO-ORG
		6	n/c	-
		7	+5 VDC IN	RED
CN2	.100" 6-Pin Header	1	Ground	BLK
		2	MISO Output Data	VIO-BLK
		3	MOSI Input Data	VIO-BRN
		4	SCK Serial Clock	VIO-RED
		5	RCK Register Clock	VIO-ORG
		6	V+	RED
CN3	.100" 5-Pin Header	1	+5 VDC	-
		2	LP-12 Light Return	-
		3	LP-11 Light Return	-
		4	LP-10 Light Return	-
		5	LP-9 Light Return	-

### 4.12 RIGHT RAMP LED BOARD 9B 520-7054-00

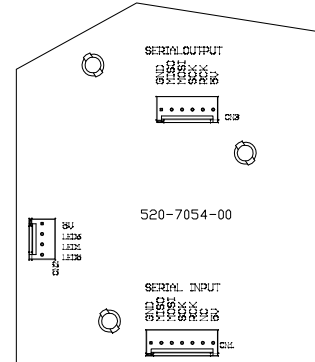

ID	Type	Pin	Description	Wire Color
CN1	.100" 7-Pin Header	1	Ground	BLK
		2	MISO Output Data	VIO-BLK
		3	MOSI Input Data	VIO-BRN
		4	SCK Serial Clock	VIO-RED
		5	RCK Register Clock	VIO-ORG
		6	n/c	-
		7	+5 VDC IN	RED
CN2	.100" 4-Pin Header	1	+5 VDC	RED
		2	LP-6 Light Return	-
		3	LP-1 Light Return	ORG-YEL
		4	LP-5 Light Return	ORG-GRN
CN3	.100" 6-Pin Header	1	Ground	BLK
		2	MISO Output Data	VIO-BLK
		3	MOSI Input Data	VIO-BRN
		4	SCK Serial Clock	VIO-RED
		5	RCK Register Clock	VIO-ORG
		6	V+	RED



### 4.13 SERIAL 16 LED BOARD 9C

520-6831-01

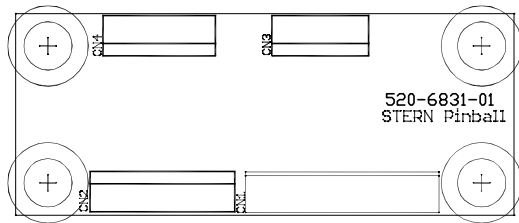

ID	Type	Pin	Description	Wire Color
CN1	.100 in 12-Pin Housing	1	LED15	-
		2	LED14	-
		3	LED13	-
		4	LED12	-
		5	LED11	-
		6	LED10	-
		7	LED9	BLU-YEL
		8	LED8	GRN-YEL
		9	LED7	RED-YEL
		10	+5 VDC LED Supply	RED
		11	+5 VDC LED Supply	RED
		12	+5 VDC LED Supply	RED
CN2	.100 in 9-Pin Housing	1	LED6	-
		2	LED5	-
		3	LED4	ORG-GRY
		4	LED3	ORG-VIO
		5	LED2	ORG-BLU
		6	LED1	ORG-GRN
		7	LED0	ORG-YEL
		8	+5 VDC LED Supply	-
		9	+5 VDC LED Supply	RED
CN3	.100" 6-Pin Header	1	Ground	BLK
		2	DIN	VIO-BLK
		3	DOUT	VIO-BRN
		4	SCK	VIO-RED
		5	RCK	VIO-ORG
		6	V+	RED
CN4	.100 in 7-Pin Housing	1	Ground	BLK
		2	MISO Output Data	VIO-BLK
		3	MOSI Input Data	VIO-BRN
		4	SCK Serial Clock	VIO-RED
		5	RCK Register Clock	VIO-ORG
		6	n/c	-
		7	+5 VDC IN	RED

### 4.14 SERIAL MOTOR DRIVER BOARD 9D

520-6996-00

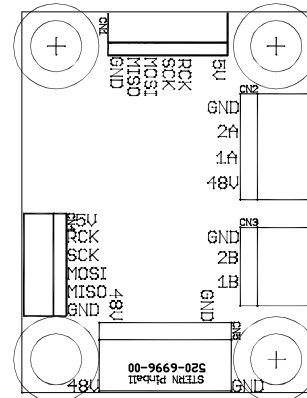

ID	Type	Pin	Description	Wire Color
CN1	.100" 7-Pin Header	1	Ground	BLK
		2	MISO Output Data	VIO-BLK
		3	MOSI Input Data	VIO-BRN
		4	SCK Serial Clock	VIO-RED
		5	RCK Register Clock	VIO-ORG
		6	n/c	-
		7	+5 VDC IN	RED
CN2	.156 4-Pin Connector	1	Ground	-
		2	DRIVE2-A	BRN-RED
		3	DRIVE1-A	GRY-RED
		4	V+	-
CN3	.156 3-Pin Connector	1	Ground	-
		2	DRIVE2-B	BRN-YEL
		3	DRIVE1-B	GRY-YEL
CN4	.100" 6-Pin Header	1	Ground	-
		2	MISO Output Data	-
		3	MOSI Input Data	-
		4	SCK Serial Clock	-
		5	RCK Register Clock	-
		6	V+	-
CN5	.156 5-Pin Connector	1	GND	BLK
		2	KEY	Key
		3	N/C	-
		4	N/C	-
		5	+48 VDC IN	GRY



### 4.15 SPI CORE PLAYFIELD NODE 10 520-6976-72

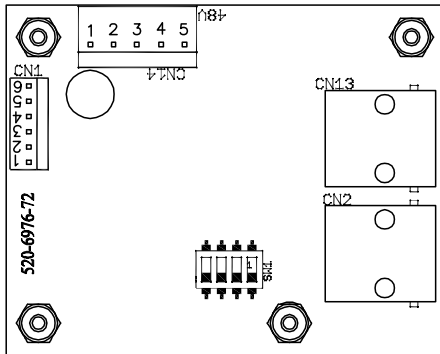

ID	Type	Pin	Description	Wire Color
SW1	Address DIP	-	Node 10 - OFF-ON-OFF-OFF	-
CN2	RJ45	-	SPIKE Node Bus	Multi
CN13	RJ45	-	SPIKE Node Bus	Multi
CN14	.156" 5-Pin Header Node Power	1	Ground	BLK
		2	Key	Key
		3	N/C	-
		4	N/C	-
		5	48VDC In	GRY
CN1	.100" 6-Pin Header, Node Extension Bus	1	Ground	BLK
		2	DIN	VIO-BLK
		3	DOUT	VIO-BRN
		4	SCK	VIO-RED
		5	RCK	VIO-ORG
		6	V+	RED

### 4.16 MAIN POWER SUPPLY 011-5003-00

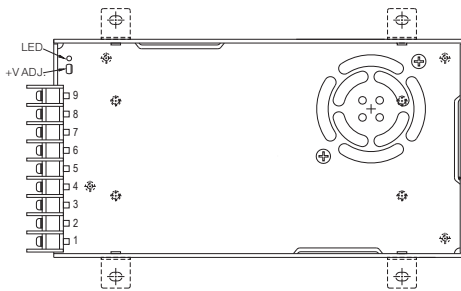

ID	Type	Pin	Description	Wire Color
CN1	Screw Terminal	1	AC Line Hot In	BLK
		2	AC Line Neutral In	WHT
		3	Earth Ground In	GRN
		4	DC Ground	BLK
		5	DC Ground	BLK
		6	DC Ground	BLK
		7	+48 V System Power	GRY
		8	+48 V System Power	GRY
		9	+48 V System Power	GRY

### 4.17 MAIN LED BOARD 10A 520-7052-00

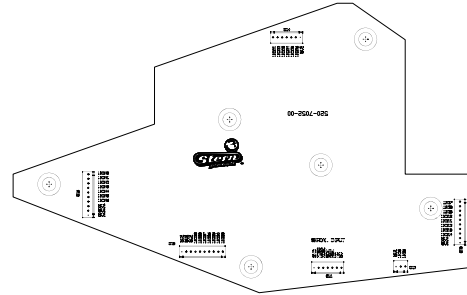

ID	Type	Pin	Description	Wire Color
CN1	.100" 7-Pin Header	1	Ground	BLK
		2	MISO Output Data	VIO-BLK
		3	MOSI Input Data	VIO-BRN
		4	SCK Serial Clock	VIO-RED
		5	RCK Register Clock	VIO-ORG
		6	n/c	-
		7	+5 VDC IN	RED
CN2	.100" 3-Pin Header	1	+5 VDC	RED
		2	LP-6 Light Return	-
		3	LP-5 Light Return	ORG
CN3	.100" 10-Pin Header	1	+5 VDC	RED
		2	+5 VDC	RED
		3	LP-14 Light Return	BRN-GRN
		4	LP-13 Light Return	BRN-YEL
		5	LP-12 Light Return	BLU-YEL
		6	LP-11 Light Return	GRN-YEL
		7	LP-10 Light Return	RED-YEL
		8	LP-9 Light Return	BLU-ORG
		9	LP-8 Light Return	GRN-ORG
		10	LP-7 Light Return	RED-ORG
CN4	.100" 7-Pin Header	1	+5 VDC	RED
		2	LP-26 Light Return	BLU-VIO
		3	LP-25 Light Return	GRN-VIO
		4	LP-24 Light Return	RED-VIO
		5	LP-23 Light Return	BLU-BRN
		6	LP-22 Light Return	GRN-BRN
		7	LP-21 Light Return	RED-BRN
CN5	.100" 10-Pin Header	1	+5 VDC	RED
		2	+5 VDC	RED
		3	+5 VDC	RED
		4	LP-39 Light Return	-
		5	LP-38 Light Return	BRN-RED
		6	LP-37 Light Return	BRN
		7	LP-36 Light Return	BRN-BLK
		8	LP-35 Light Return	ORG-RED
		9	LP-34 Light Return	ORG-BRN
		10	LP-33 Light Return	ORG-BLK
CN6	.100" 10-Pin Header Orange	1	+5 VDC	RED
		2	+5 VDC	RED
		3	+5 VDC	-
		4	LP-46 Light Return	-
		5	LP-45 Light Return	-
		6	LP-44 Light Return	-
		7	LP-43 Light Return	ORG-GRN
		8	LP-42 Light Return	ORG-BLU
		9	LP-41 Light Return	ORG-VIO
		10	LP-40 Light Return	ORG-GRY



# 4.18 BACKPANEL 48V DRIVER PINOUT NODE 11

520-6998-72

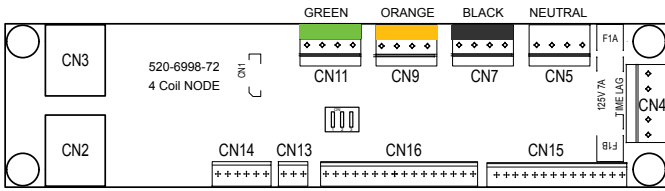

ID	Type	Pin	Description	Wire Color
SW1	Address DIP	-	Node 11 - OFF-ON-ON-OFF	
CN1	-	-	N/C	-
CN2	RJ45	-	SPIKE Node Bus	Multi
CN3	RJ45	-	SPIKE Node Bus	Multi
CN4	.156" 5-Pin Header Node Power	1	Ground	BLK
		2	Key	KEY
		3	N/C	-
		4	N/C	-
		5	48VDC In	GRY
CN5	.156" 4-Pin Header (White)	1	Switch Ground	-
		2	11-SW-0 Switch Return	-
		3	11-DR-0 Driver Return	BRN-RED
		4	48V Driver Power	GRY-BLK
CN7	.156" 4-Pin Header (Black)	1	Switch Ground	-
		2	11-SW-1 Switch Return	-
		3	11-DR-1 Driver Return	BRN-ORG
		4	48V Driver Power	GRY-BLK
CN9	.156" 4-Pin Header (Orange)	1	Switch Ground	-
		2	11-SW-2 Switch Return	-
		3	11-DR-2 Driver Return	BRN-YEL
		4	48V Driver Power	GRY-BLK
CN11	.156" 4-Pin Header (Green)	1	Switch Ground	-
		2	11-SW-3 Switch Return	-
		3	11-DR-3 Driver Return	BRN-GRN
		4	48V Driver Power	GRY-BLK
CN13	.100" 3-Pin Header	1	11-LP-0 GI Return (1A Max)	-
		2	GI Ground	-
		3	LED V+	-
CN14	.100" 6-Pin Header	1	Ground	-
		2	DIN	-
		3	DOUT	-
		4	SCK	-
		5	RCK	-
		6	V+	-

CN15	.100" 14-Pin Header	1	+5V	RED
		2	11-SW-4 Switch Return	WHT-BLU
		3	11-SW-5 Switch Return	WHT-VIO
		4	11-SW-6 Switch Return	WHT-GRY
		5	11-SW-7 Switch Return	WHT
		6	11-SW-8 Switch Return	-
		7	11-SW-9 Switch Return	-
		8	11-SW-10 Switch Return	-
		9	11-SW-11 Switch Return	-
		10	11-SW-12 Switch Return	-
		11	11-SW-13 Switch Return	-
		12	11-SW-14 Switch Return	-
		13	11-SW-15 Switch Return	-
		14	Switch Ground	BLK-WHT
CN16	.100" 16-Pin Header	1	+6V	-
		2	11-LP-1 Light Return	-
		3	11-LP-2 Light Return	-
		4	11-LP-3 Light Return	-
		5	11-LP-4 Light Return	-
		6	11-LP-5 Light Return	-
		7	11-LP-6 Light Return	-
		8	11-LP-7 Light Return	-
		9	11-LP-8 Light Return	-
		10	11-LP-9 Light Return	-
		11	11-LP-10 Light Return	-
		12	11-LP-11 Light Return	-
		13	11-LP-12 Light Return	-
		14	11-LP-13 Light Return	-
		15	11-LP-14 Light Return	-
		16	11-LP-15 Light Return	-
F1	Fuse		7A SB, 125V	n/a



## 4.19 POWER DISTRIBUTION BOARD

### 520-5343-01

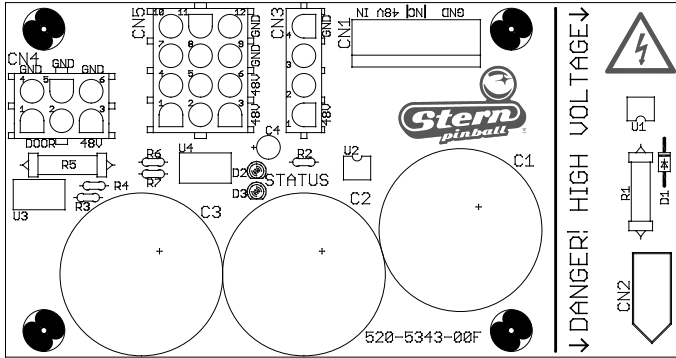

ID	Type	Pin	Description	Wire Color
CN1	.156 in 7-Pin Housing Plug: 045-5259-07 Pin: 055-5331-00 Key: 060-5013-00	1	+48 VDC IN	GRY
		2	+48 VDC IN	GRY
		3	+48 VDC IN	GRY
		4	Key (n/c)	-
		5	Ground	BLK
		6	Ground	BLK
		7	Ground	BLK
CN2	.093 in 3-Pos Plug Plug: 045-5003-03 Pin: 055-5013-09	1	Line In (100-240 VAC)	BLK
		2	Neutral	WHT
		3	Earth Ground	GRN
CN3	0.084 in 4-Pos Plug Plug: 045-5200-04 Pin: 055-5033-08	1	+48 VDC to CPU Node	GRY
		2	Door Interlock Switch Status	GRY/RED
		3	Line Voltage Status	VIO
		4	Ground	BLK
CN4	0.084 in 6-Pos Plug Plug: 045-5200-06 Pin: 055-5033-08	1	Door Interlock Switch +48V	-
		2	Door Interlock Switch +48V	-
		3	Switched 48V Out (to Node 1)	GRY/YEL
		4	Door Interlock Return Ground	-
		5	Door Interlock Return Ground	-
		6	Ground (to Node 1)	BLK
CN5	0.084 in 12-Pos Plug Plug: 045-5200-12 Pin: 055-5033-08	1	Switched 48V Node Power	GRY
		2	Switched 48V Node Power	GRY
		3	Switched 48V Node Power	GRY
		4	Switched 48V Node Power	GRY
		5	Switched 48V Node Power	GRY
		6	Switched 48V Node Power	GRY
		7	Node Ground	BLK
		8	Node Ground	BLK
		9	Node Ground	BLK
		10	Node Ground	BLK
		11	Node Ground	BLK
		12	Node Ground	BLK
CN6	.156 in 3-Pos Plug: 045-5259-03 Pin: 055-5331-00 (18awg)	1	Ground	-
		2	Ground	-
		3	+12VDC	-
CN7	.084 2-Pos Plug: 045-5200-02 Pin: 055-5033-08	1	+48 VDC to CPU Node	-
		2	Ground	-

## 4.20 POWER PLUG WIRING

**CAUTION**

**TO MAINTAIN SAFETY, GROUND WIRE FROM LINE FILTER IS TO BE MOUNTED FIRST ON GROUNDING STUD AND SECURED WITH NUT. ALL OTHER GROUNDS MAY THEN BE ATTACHED TO GROUNDING STUD.**

**REPLACE ALL FUSES WITH CORRECT CURRENT RATINGS!**

### NORTH AMERICA

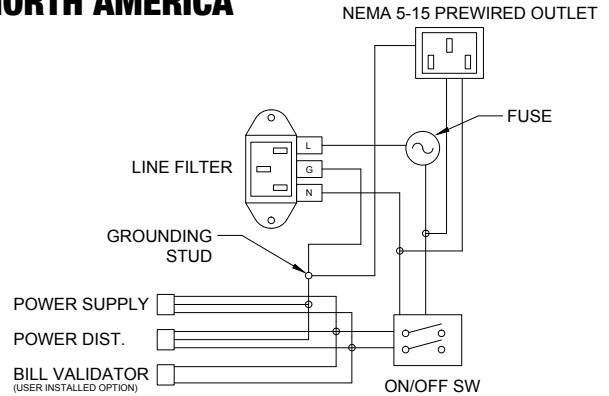

### INTERNATIONAL

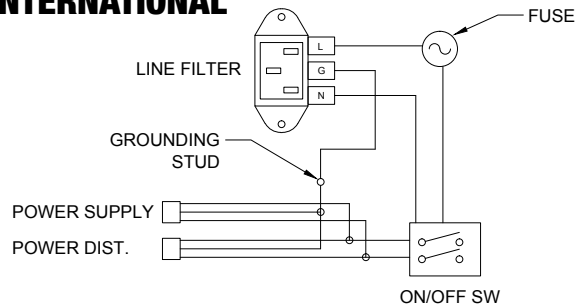

### LINE CORDS

Part Number	Description
034-6012-00	Line Cord, 3m, 5-15P USA
034-6012-01	Line Cord, 3m, CEE77P EUROPE
034-6012-02	Line Cord, 3m, BS1363P United Kingdom
034-6012-03	Line Cord, 3m, AS-NZS4417P Australia
034-6012-04	Line Cord, 3m, CEI23-16P Italy
034-6012-05	Line Cord, 3m, SEV1011P Switzerland
034-6012-06	Line Cord, 3m, JIS8303P Japan
034-6012-07	Line Cord, 3m, SI32P Israel
034-6012-08	Line Cord, 3m, BS546P S Africa, India
034-6012-09	Line Cord, 3m, IS6538P S. India

### LINE FUSES

Line Voltage (Region)	Fuse Current	Type	Part Number
120V (North America)	8 A	Slow Blow MDL	200-5000-05
220/240v (Europe, Australia, UK)	5 A	Slow Blow MDL	200-5000-01



# 5. PARTS REFERENCE

## 5.1 PLAYFIELD RUBBER PARTS

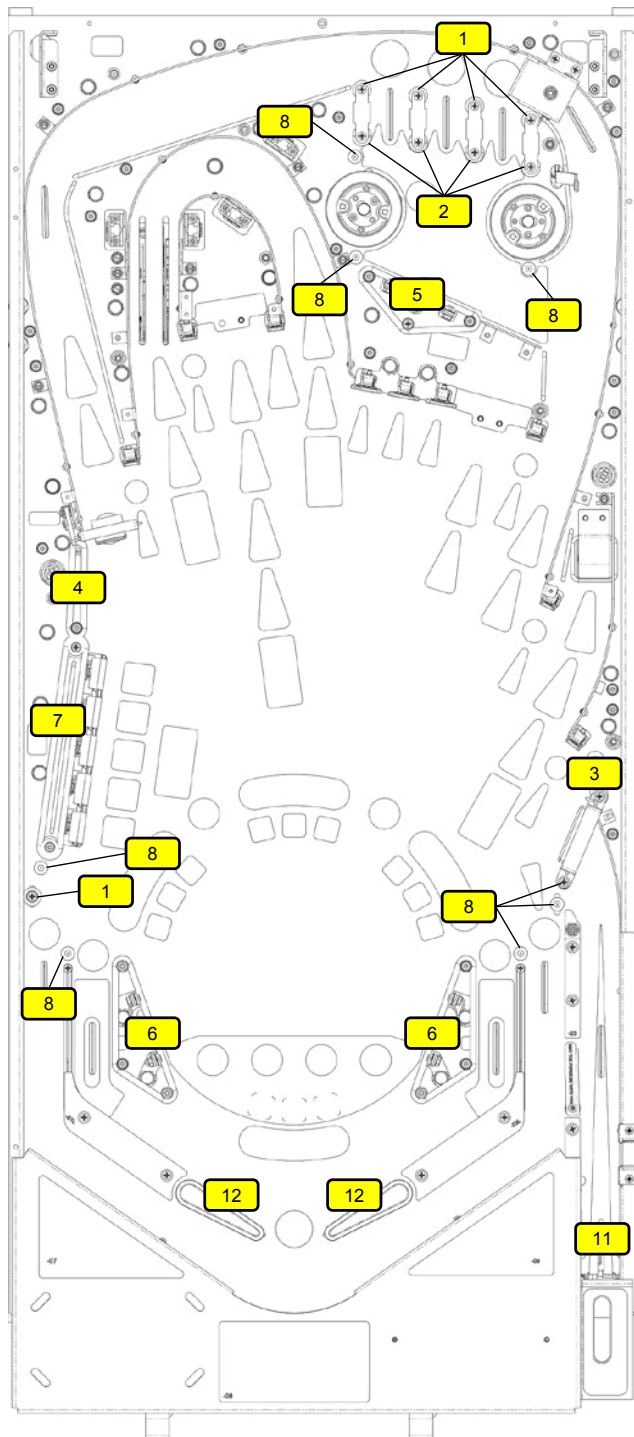

Figure 5.1.1. Rubber o-ring part locations.

## RUBBER O-RINGS

ID	Qty	Size (ID)	Size (OD)	Durometer	Color	Part Number
1	5	3/16"		50	Black	545-5348-01
2	4	5/16"		50	Black	545-5348-02
3	1	3/4"		50	Black	545-5348-04
4	1	1-1/4"		50	Black	545-5348-06
5	1	2"		50	Black	545-5348-08
6	2	2-1/2"		50	Black	545-5348-09
7	1	3-1/2"		50	Black	545-5348-11
8	9		7/16"	50	Black	545-5348-17

Figure 5.1.2. Rubber o-ring part numbers and usage. ID: Inner Diameter, OD: Outer Diameter, Durometer: Higher number is firmer, less bounce, and more durable.

ID	Qty	Description	Color	Part Number
11	1	Plunger Tip	Black	545-5276-00
12	2	Flipper Rubber	Black	545-5277-00
13	2	Bumper Pad (Sub assemblies)	Black	545-5105-00
14	2	Bumper Pad (Flippers)	Black	545-5428-00

Figure 5.1.3. Other rubber part numbers and usage

## 5.2 RUBBER SIZE CHART

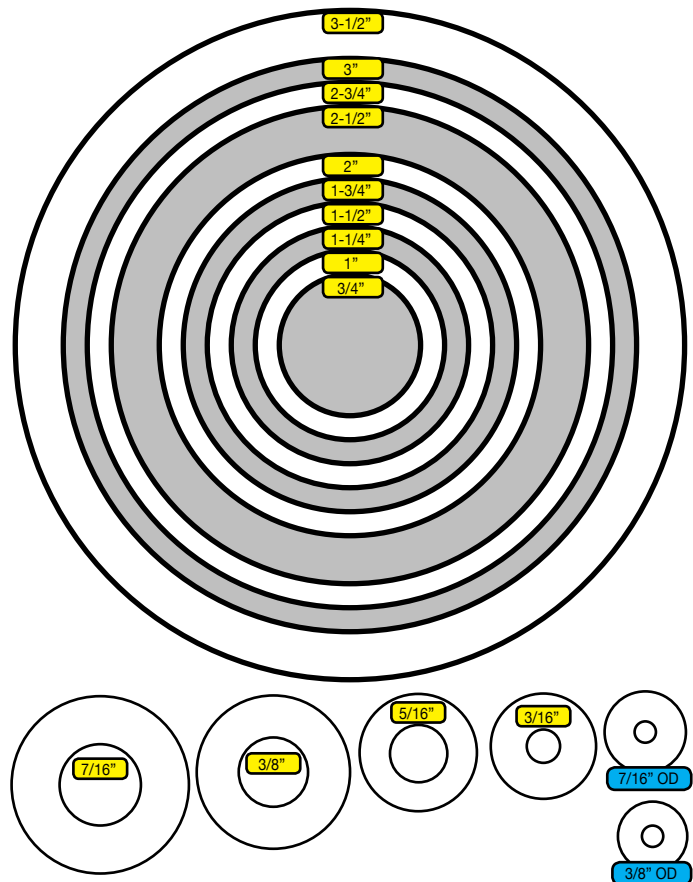
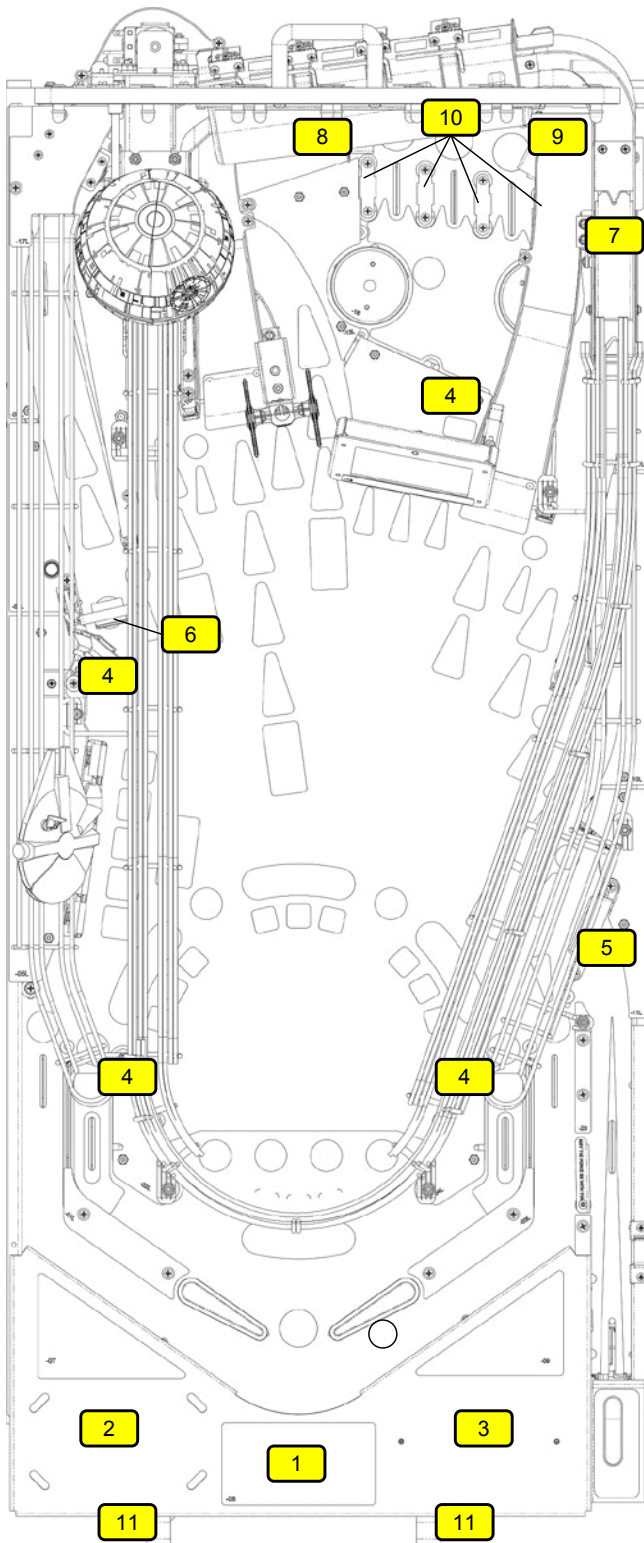

Figure 5.2.1. Rubber ring inner diameter sizing tool. Hold ring up to chart and read largest size on inside of ring. Dimensions are Inner Diameter (ID) unless otherwise noted as Outer Diameter (OD).

## 5.3 PLAYFIELD ASSEMBLIES, TOP



ID	Part Number	Description	Qty
1	545-5995-02	Bottom Arch Assembly	1
2	755-51J5-12-Y	Instruction Card	1
3	755-5400-02-Y	Coin Card (USA)	1
4	545-5409-01	Light Reflector	6
	535-1324-01	Bracket Support	6
	545-5409-01	Reflector	6
	077-5026-01	Socket	6
5	511-7888-05	1-Way Gate	1
6	511-7877-00	Spinner	1
7	500-1064-00	Accelerator Exit Diverter	1
8	511-5096-00	Electric Gate	1
9	511-5033-03	Electric Gate	1
10	550-5061-05	Blue Hood	4
11	535-8385-00	Welded Hanger Bracket	2

Figure 5.3.1. Major playfield assemblies, Top locations.

## 5.4 PLAYFIELD ASSEMBLIES, BOTTOM

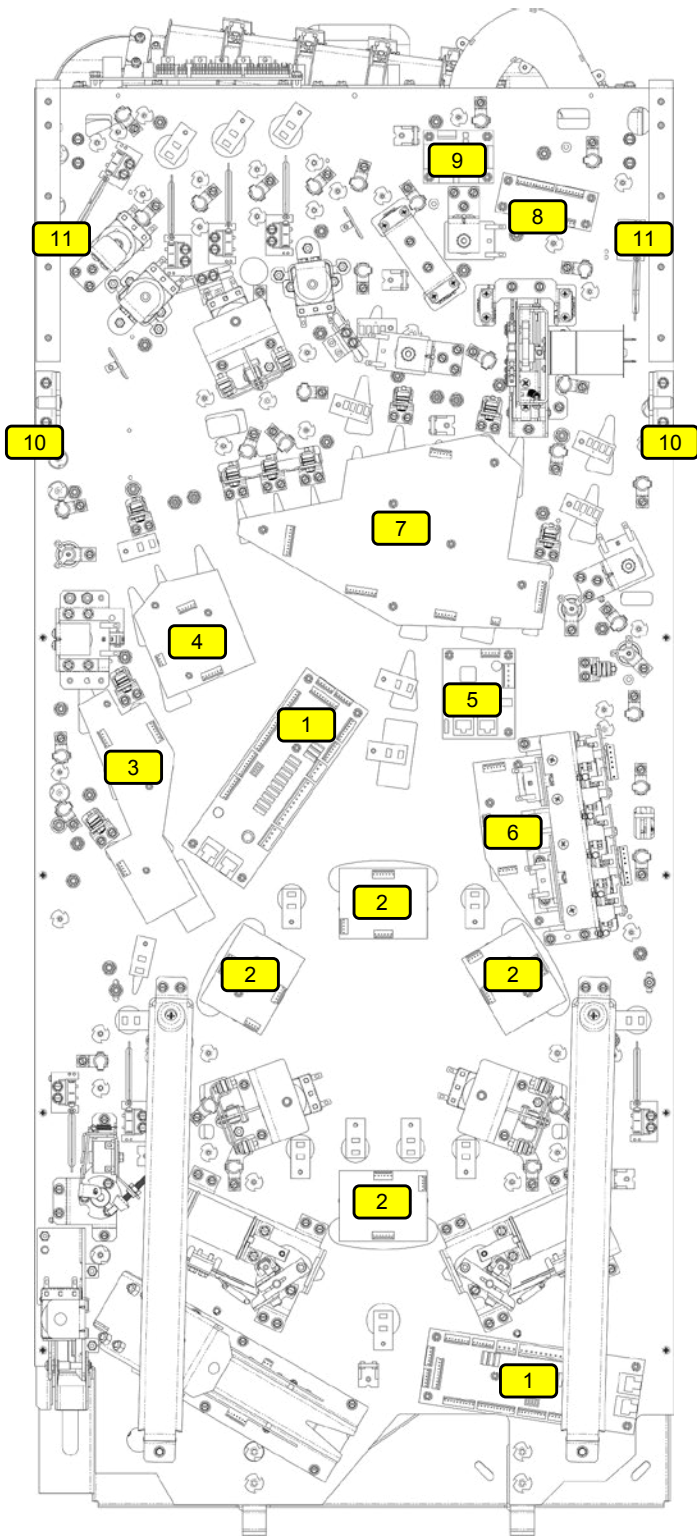

ID	Part Number	Description	Qty
1	520-7017-72	Core Node	2
2	520-7042-00	LED Board - Mode Small	4
3	520-7053-00	LED Board - Right Eject	1
4	520-7054-00	LED Board - Right Ramp	1
5	520-6976-72	SPF Node	1
6	520-7043-00	LED Board - Five Bank	1
7	520-7052-00	LED Board - Main	1
8	520-6831-01	Serial 16 LED Board	1
9	520-6996-00	Serial Motor Driver Board	1
10	500-5329-03	Pivot Pin	2
11	535-5988-01	Edge Slide Bracket	2
	064-5004-08-03	RJ45 Cable 3ft	3
	064-5004-08-10	RJ45 Cable 10ft	2
	604-5300-06	HDMI Cable	2
	045-5267-00	HDMI Coupler	2

Figure 5.4.1. Major playfield assemblies, Bottom locations.

## 5.5 BACKBOX PARTS

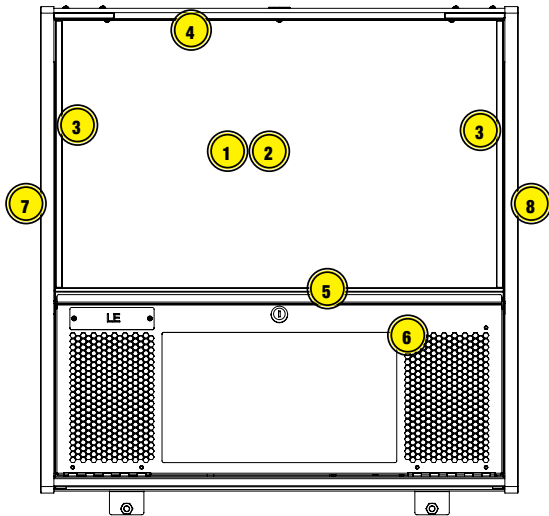

Figure 5.5.1. Backbox external assemblies and components.

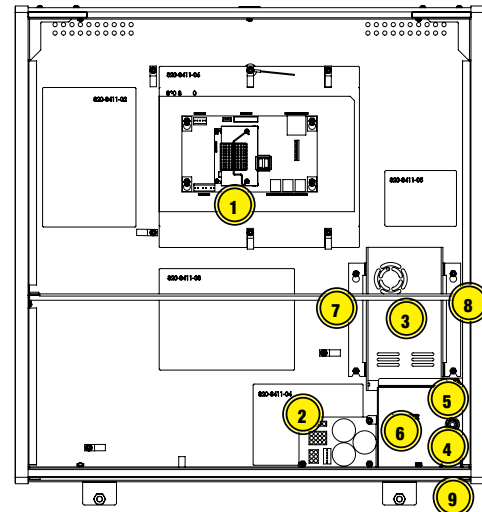

Figure 5.5.2. Backbox internal assemblies and components.

### EXTERNAL

ID	Part Number	Description	Qty
1	660-5052-00	Backglass	1
2	830-52J6-00	Translite Art [LE]	1
	830-52J7-00	Translite Art [Premium]	1
3	545-5018-17	Plastic Extrusion 15-.450"	2
4	545-5018-15	Glass Channel 26"	1
5	545-6313-01	Glass Lift Channel 26"	1
6	500-9996-J6	LCD Speaker Panel Assembly	1
7	820-78J6-01	Left Backbox Decal [LE]	1
	820-78J7-01	Left Backbox Decal [Premium]	1
8	820-78J6-02	Right Backbox Decal [LE]	1
	820-78J7-02	Right Backbox Decal [Premium]	1

### INTERNAL

ID	Part Number	Description	Qty
1	509-1003-01	CPU Node Board	1
2	520-5343-01	Power Distribution Board	1
3	011-5003-00	Power Supply 48V/500W	1
4	515-9769-00	Utility Outlet (USA)	1
5	205-5001-00	Fuse Holder-Screw in	1
	200-5000-05	8A Fuse	1
6	535-1130-00	Cover AC	1
7	535-1129-00	Power supply bracket	1
8	535-1129-01	Power supply bracket	1
9	180-5001-03	Power Switch	1
	034-6012-00	Line Cord-3M 5-15P/C13RA*	1

## 5.6 SPEAKER PANEL PARTS

### 500-9996-J6/J7

ID	Part Number	Description	Qty
1	031-5004-02	Speaker	2
2	116-0023-00	1366 x 768 Display LCD Panel	1
3	237-6188-01	Screw, M3x0.5 X 6MM PPH Sems Zinc	4
4	237-6307-06	6-32 X 3/8" Torx Stainless Steel Screw	2
5	240-5005-00	6-32 Nylon Stop Nut	12
6	242-5001-00	#6 Washer	16
7	355-5168-00-00	Nut: Lock w/ Cam	1
8	515-9842-00	Speaker Panel-LCD	1
9	515-9843-00	Speaker Plate	2
10	515-9845-00	Hinge, Speaker Panel, LCD	2
11	545-9877-00	LCD Window	1
12	545-9877-01	Spacer, Small - LCD Speaker Panel	4
13	626-5109-00	Speaker Foam - LCD Panel	2
14		Logo Plate	1

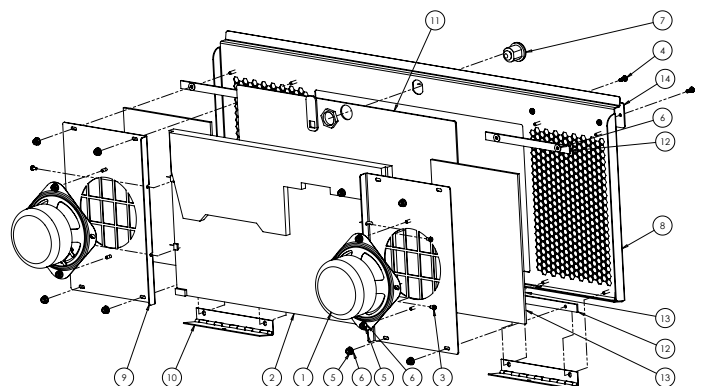

# 5.7 CABINET PARTS

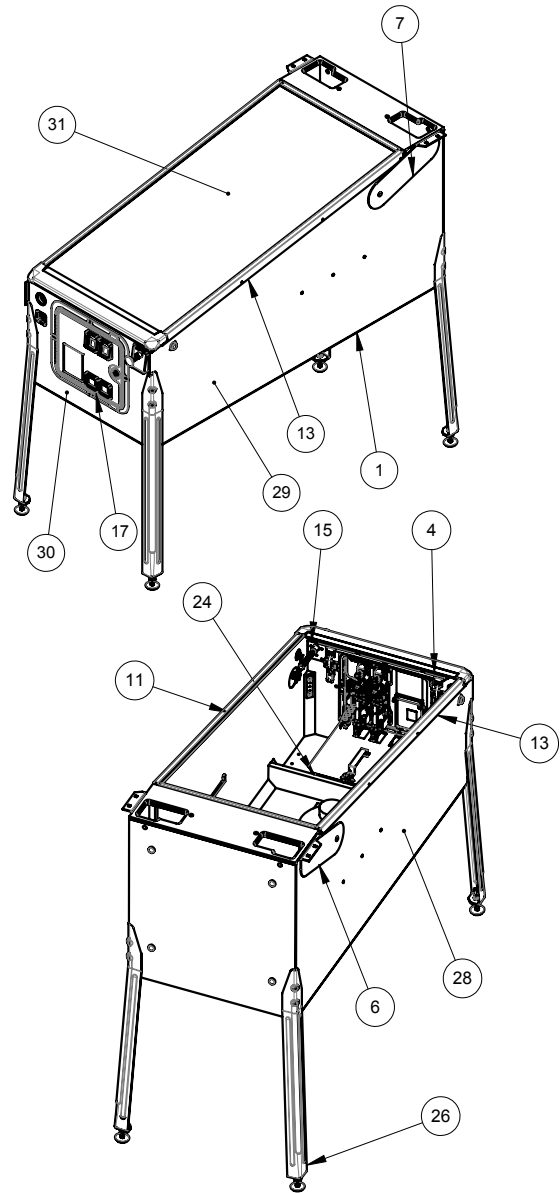
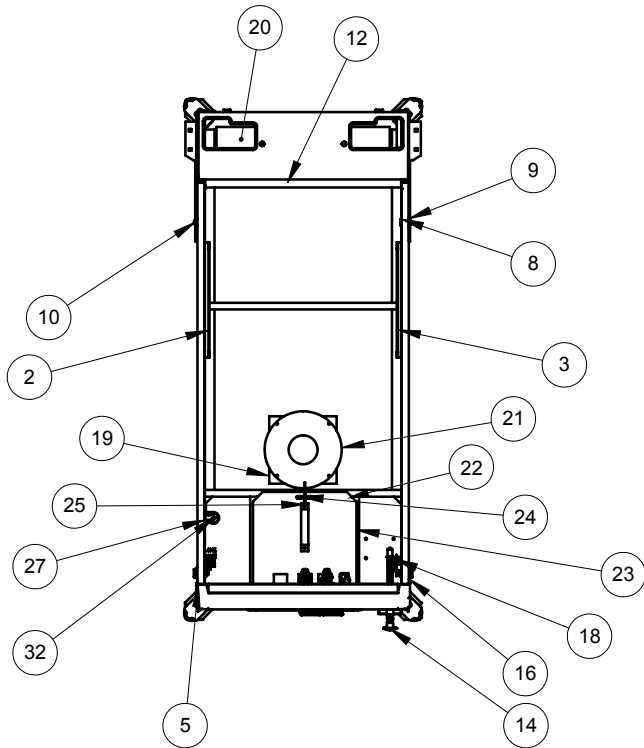

ID	Part Number	Description	Qty
1	525-6012-00	Cabinet (Plunger & Two Buttons)	1
2	535-1680-00	Slide & Pivot Bracket - Left Side	1
3	535-1680-00	Slide & Pivot Bracket - Right Side	1
4	515-7792-00	Cabinet Playfield Support Bracket	1
5	500-2440-25	Front Molding Assembly [LE]	1
	500-2440-00	Front Molding Assembly - Wrinkle Black [Premium]	1
6	535-7999-25L	Pivot Hinge, Left [LE]	1
	535-7999-00	Pivot Hinge, Left - Wrinkle Black [Premium]	1
7	535-7999-25R	Pivot Hinge, Right [LE]	1
	535-7999-01	Pivot Hinge, Right - Wrinkle Black [Premium]	1
8	254-5042-00	Spacer Nut, Hex, 1/2"OD, 1/4-20	2
9	242-5084-00	Washer, 1/2" I.D., 3/16" THK	2
10	231-5072-00	1/4-20 X 1/2" Carriage Bolt	2
11	545-5017-00	Plastic Channel	2
12	545-5038-00	Glass Rear Extrusion	1
13	535-1729-25-00	Side Armor Left [LE]	1
	535-1729-25-01	Side Armor Right [LE]	1
	535-7297-02	Side Armor - Wrinkle Black [Premium]	2
14	500-6146-00-04	Ball Shooter Assembly	1
15	535-5027-01	Plunger Support Plate, Notched	1
16	500-5026-38	Flipper Button Assembly (White)	2
17	501-5018-173	Coin Door 2-Chute No Emboss	1
18	180-5160-01	Flipper Switch, Single	2
19	545-5072-03	Grill - Speaker / Vent	1
20	545-5072-02	Grill - Speaker / Vent	1
21	031-5007-01	Speaker, Cabinet 8" Round, 4 ohm	1

22	545-5090-00	Cash Box - Plastic	1
23	535-5013-03	Cash Box Cover	1
24	535-7562-00	Cash Box Lock Bracket Wire	1
25	535-7772-00	Hair Pin Clip	1
26	500-5921-25	Leg Assembly [LE]	4
	500-5921-50	Leg Assembly - Wrinkle Black [Premium]	4
27	516-0007-00	Tilt Assembly	1
28	820-78J6-03	Decal, Cabinet Left, Star Wars LE	1
	820-78J7-03	Decal, Cabinet Left, Star Wars Premium	1
29	820-78J6-04	Decal, Cabinet Right, Star Wars LE	1
	820-78J7-04	Decal, Cabinet Right, Star Wars Premium	1
30	820-78J6-05	Decal, Cabinet Front, Star Wars LE	1
	820-78J7-05	Decal, Cabinet Front, Star Wars Premium	1
31	660-5001-00	Playfield Glass	1
32	520-6967-72	Cabinet Node Board	1
	820-78J6-XX	Cabinet Decal Replacement Set	
	820-78J7-XX		



### 5.8 BALL SHOOTER ASSEMBLY

500-6146-00-04

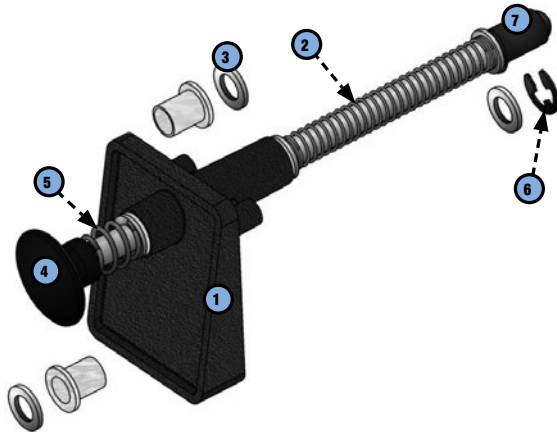

ID	Part Number	Description	Qty
1	535-5067-02	Housing Assembly	1
2	266-5001-04	Compressed Spring (Long) - Green	1
3	242-5014-00	Washer 3/8 ID x 5/8 OD x 1/16	3
4	515-6557-00	Rod Assembly	1
5	266-5010-00	Compressed Spring (Short)	1
6	270-5012-00	Retaining Ring, 3/8"	1
7	545-5276-00	Rubber Tip	1

### 5.9 AUTO LAUNCH ASSEMBLY

500-9818-01

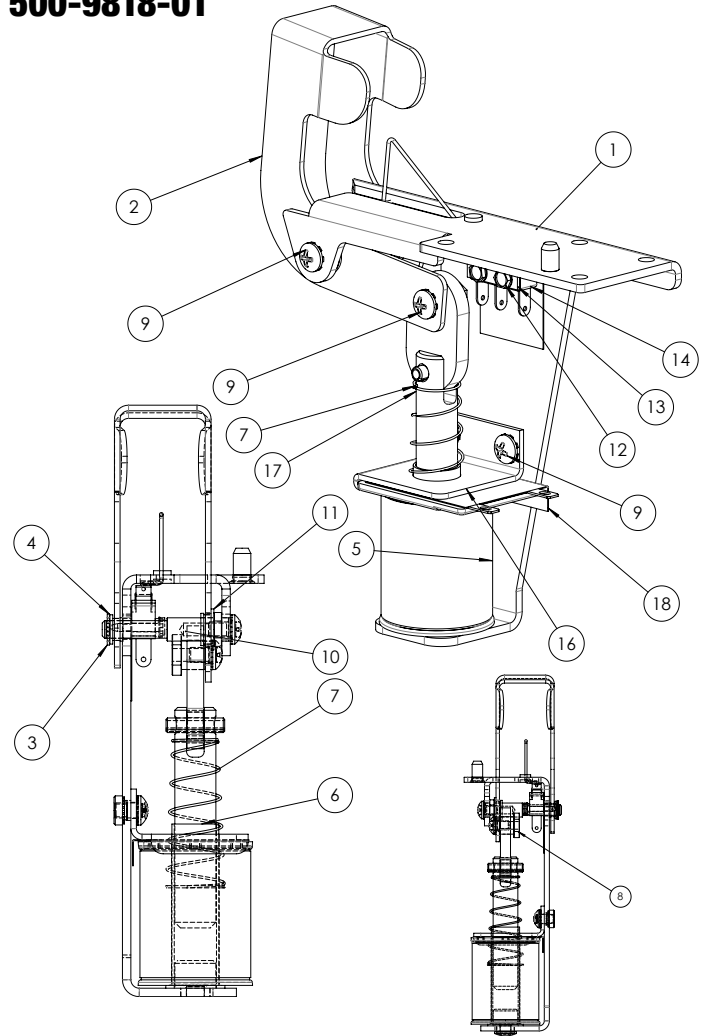

ID	Part Number	Description	Qty
1	515-9689-00	MAIN BRKT: AUTO-PLUNGER	1
2	535-0728-00	KICKER ARM, AUTO-PLUNGER	1
3	270-5001-00	RETAINING E-RING, 3/16" SHAFT OD	1
4	545-5352-00	NYLINER, 3/16" SHAFT	1
5	090-5001-ND	COIL - 23-800, NO DIODE	1
6	545-5411-00	COIL SLEEVE	1
7	266-5020-00	COMPRESSION SPRING-CONICAL	1
8	530-7834-00	PIN: KICKER ARM, AUTO-PLUNGER	1
9	232-5300-00	SCREW, 8-32 X 1/4" PPH SEMS	4
10	530-7835-00	PIVOT, AUTO-PLUNGER	1
11	545-5423-00	NYLINER, 1/4" SHAFT, 4L1-FF	1
12	237-5937-02	SCREW, 2-56 X 1/2" HWH MS	2
13	535-6539-00	SWITCH BODY PROTECT PLATE	1
14	180-5157-01	SHOOTER SWITCH - SHORT ARM	1
15	545-6268-00	FISCHE PAPER	1
16	535-0762-00	COIL BRACKET-AUTOPLUNGER	1
17	515-6304-03	PLUNGER / LINK ASSEMBLY	1
18	545-0762-00	FISCHE PAPER: AUTO-LAUNCHER	1

## 5.10 BALL TROUGH ASSEMBLY

500-9820-00

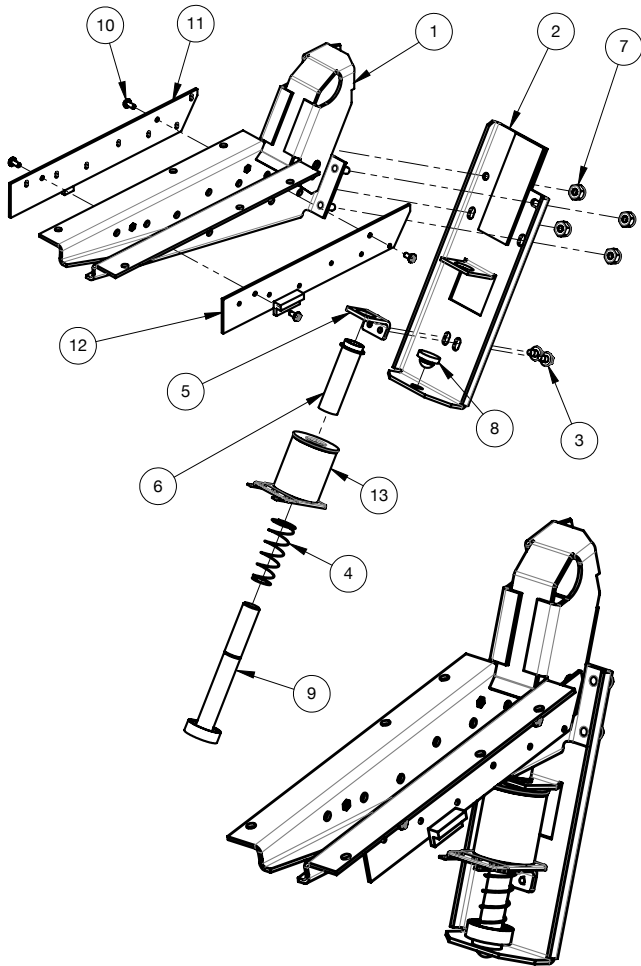

ID	Part Number	Description	Qty
1	515-7811-00	MAIN BRKT. BALL TROUGH	1
2	515-7812-00	COIL BRACKET, BALL TROUGH	1
3	237-5975-04	SCREW, 8-32 X 1/4" HWH SWAGE SERR	2
4	266-5020-00	COMPRESSION SPRING-CONICAL	1
5	535-5203-03	COIL RETAINING BRACKET	1
6	545-5076-01	COIL SLEEVE	1
7	240-5102-00	8-32 NYLON LOCK NUT	4
8	545-5105-00	RUBBER BUMPER	1
9	515-7309-01	PLUNGER ASSEMBLY	1
10	237-5909-00	SCREW, 4-40 X 1/4" PPH SEMS	4
11	520-5344-00	TROUGH BOARD #1 - ILED TRANSMITTER	1
12	520-5345-00	TROUGH BOARD #2 - RECEIVER	1
13	090-5004-ND	COIL 27-1500 - NO DIODE	1
98*	605-5006-00	SHRINK TUBING 1/8"	.42 FT.
99*	036-5611-11-F5	CABLE TROUGH OPTOS	1

## 5.11 SLINGSHOT ASSEMBLY

500-9920-01

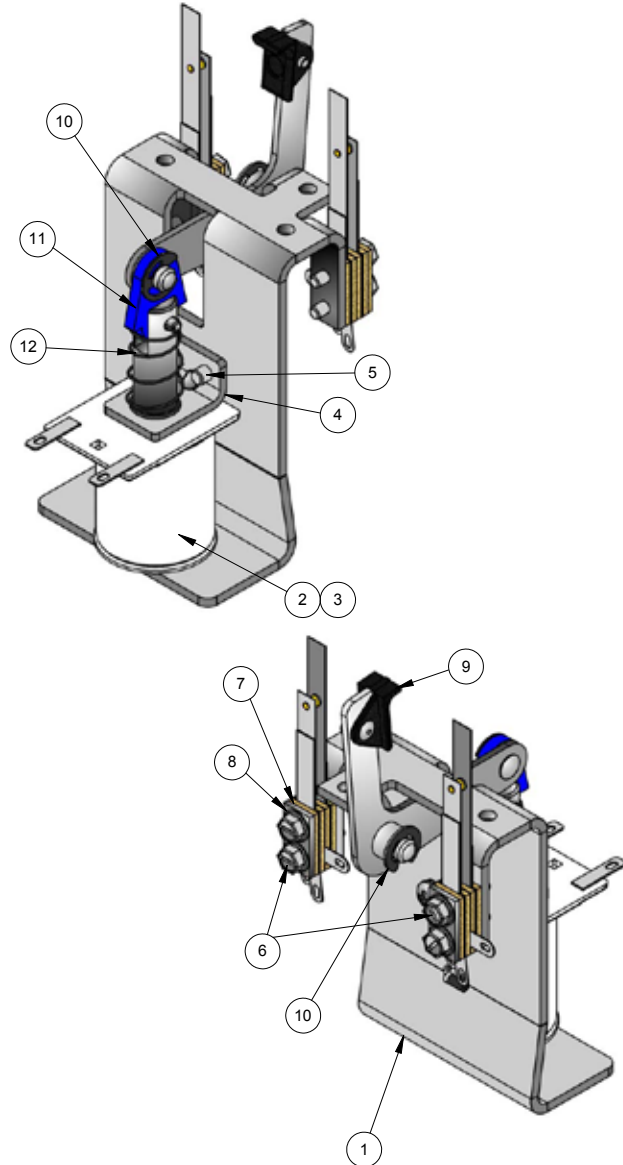

ID	Part Number	Description	Qty
1	515-5339-01	SLINGSHOT BRACKET ASSEMBLY	1
2	090-5044-ND	COIL 26-1200 - NO DIODE	1
3	545-5031-00	COIL SLEEVE	1
4	535-5203-03	COIL RETAINER BRACKET	1
5	232-5301-00	8-32 X 3/8 PPH MS EXT SEMS ZC	2
6	180-5231-00	SWITCH SLING SHOT 2 LUG CENTER	2
7	535-5045-00	SWITCH PLATE	2
8	237-5976-04	6-32 X 5/8 SLOT SER HWH SW	4
9	515-5340-01	ARM & TIP ASSEMBLY	1
10	270-5002-00	RETAINING RING - 1/4 DIA	2
11	515-5338-00	PLUNGER & LINK ASSEMBLY	1
12	266-5020-00	COMP SPRING CONICAL	1
13	036-5604-00	4" GENERIC JUMPER	2

## 5.12 FLIPPER ASSEMBLY, LEFT

### 500-6543-12-ND

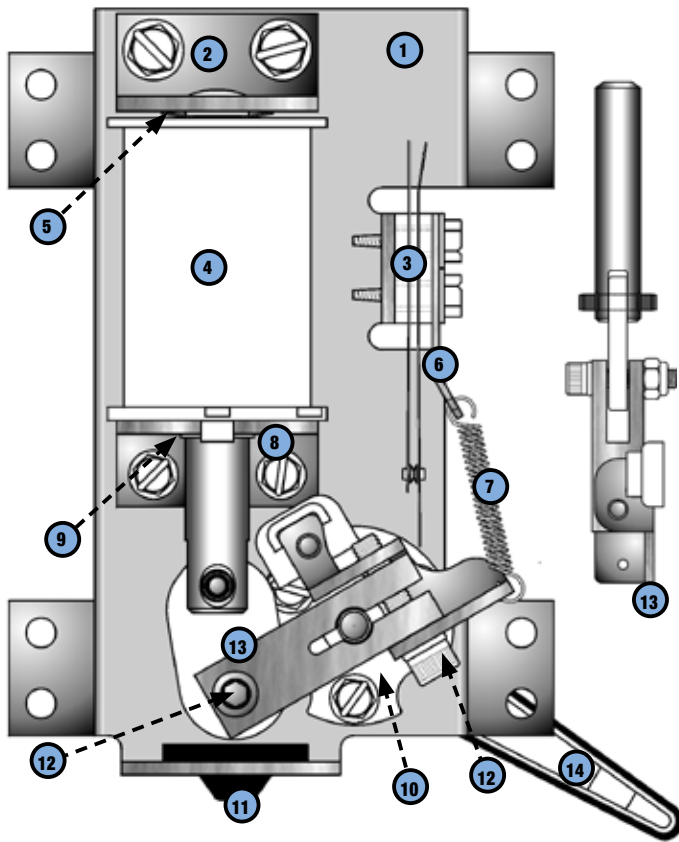

ID	Part Number	Description	Qty
1	515-6617-01	FLIPPER BASE PLATE LEFT KIT W/ BRACKET MOUNT HARDWARE	1
2	515-6308-01	COIL STOP BRACKET	1
3	180-5149-00	SWITCH - END OF STROKE N/C	1
4	090-5032-ND	COIL	1
5	269-5002-00	SPRING WASHER	1
6	535-7354-00	SWITCH RETURN SPRING BRACKET	1
7	265-5035-00	SPRING FLIPPER RETURN	1
8	535-7356-00	COIL SUPPORT BRACKET	1
9	545-5388-00	COIL SLEEVE, FLIPPER	1
10	545-5070-00	FLIPPER BAT BUSHING	1
11	545-5428-00	FLIPPER BUMPER PAD	1
12	237-6144-00	SET SCREW #10-32 x 3/4" SOCKET	2
13	515-7203-01	PLUNGER/CRANK ASSEMBLY, LEFT	1
14	515-5133-08-06	FLIPPER BAT AND SHAFT*	1
	500-6307-10	FLIPPER REBUILD KIT, LEFT	
		* Refer to game rubber chart for flipper rubber color and part number.	

## 5.13 FLIPPER ASSEMBLY, RIGHT

### 500-6543-02-ND

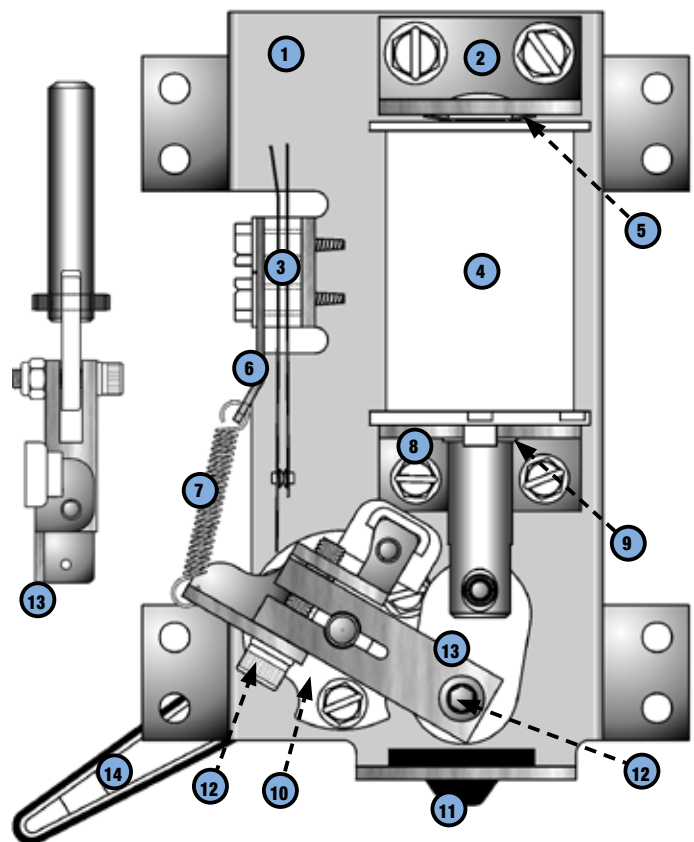

ID	Part Number	Description	Qty
1	515-6617-00	FLIPPER BASE PLATE RIGHT KIT W/ BRACKET MOUNTING HARDWARE	1
2	515-6308-01	COIL STOP BRACKET	1
3	180-5149-00	SWITCH - END OF STROKE N/C	1
4	090-5032-ND	COIL	1
5	269-5002-00	SPRING WASHER	1
6	535-7354-00	SWITCH RETURN SPRING BRACKET	1
7	265-5035-00	SPRING FLIPPER RETURN	1
8	535-7356-00	COIL SUPPORT BRACKET	1
9	545-5388-00	COIL SLEEVE, FLIPPER	1
10	545-5070-00	FLIPPER BAT BUSHING	1
11	545-5428-00	FLIPPER BUMPER PAD	1
12	237-6144-00	SET SCREW #10-32 x 3/4" SOCKET	2
13	515-7203-00	PLUNGER/CRANK ASSEMBLY	1
14	515-5133-08-06	FLIPPER BAT AND SHAFT*	1
	500-6307-00	FLIPPER REBUILD KIT, RIGHT	
		* Refer to game rubber chart for flipper rubber color and part number.	

# 5.14 POP BUMPER ASSEMBLY

516-6784-XX

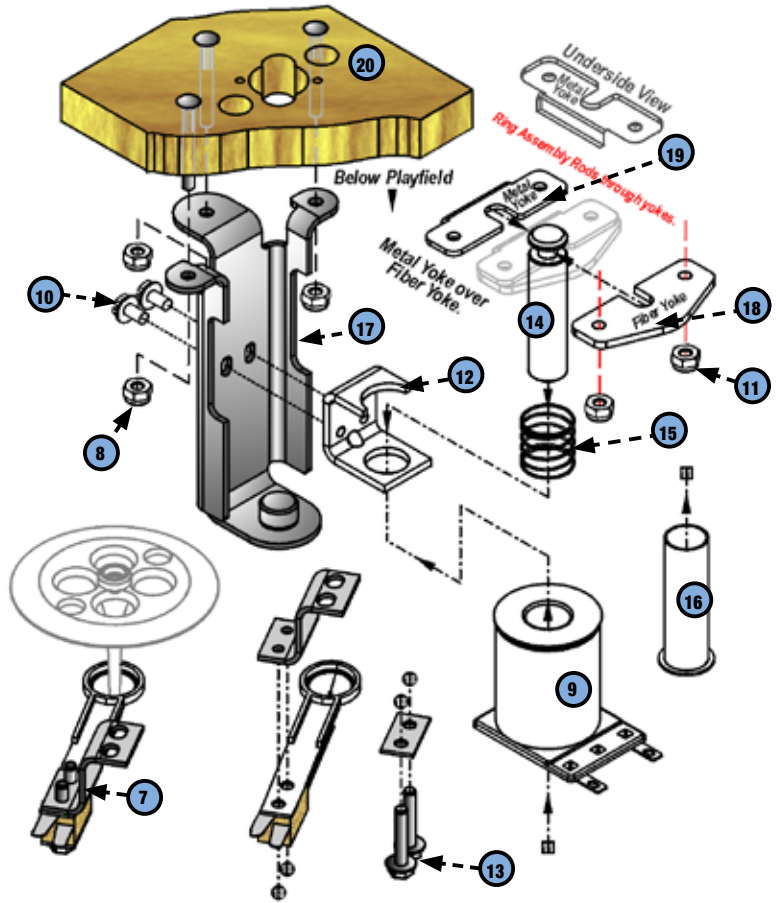
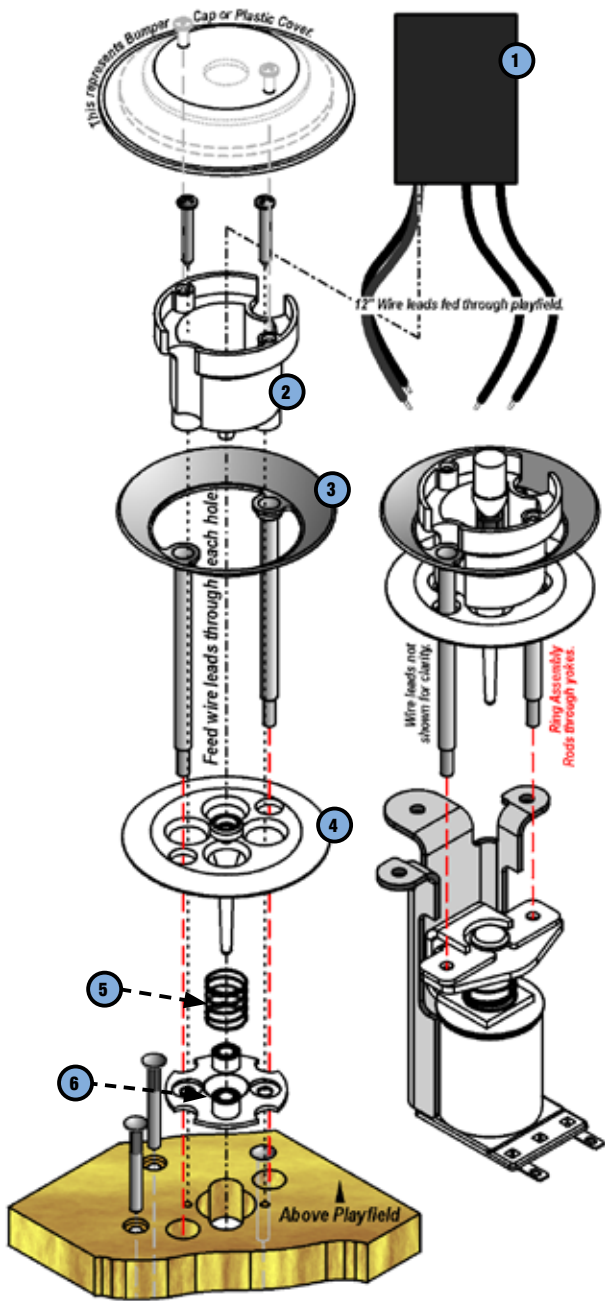

Part Number	Description	Qty
515-6459-01L	BUMPER/RING TOP ASSY, W/ LED 1	1
515-6459-04-ND	BUMPER BOTTOM ASSY, NO DIODE	1

ID	Part Number	Description	Qty
1	520-5307-03	POP BUMPER LED MODULE	1
2	545-5197-00	BUMPER BODY	1
3	515-5085-00	RING AND ROD ASSY	1
4	545-5607-00	BUMPER SKIRT	1
5	266-5048-00	BUMPER SKIRT COMP SPRING	1
6	545-5195-00	BUMPER BASE	1

ID	Part Number	Description	Qty
7	500-9934-01	POP BUMPER SWITCH ASSY-2 - LUG-LEFT	1
8	240-5005-00	6-32 NYLON STOP NUT	3
9	090-5044-ND	COIL - 26-1200	1
10	237-5976-01	#6-32 X 1/4" SHWH SWAGE ZN	2
11	240-5005-00	#6-32 NYLON STOP NUT	2
12	535-7347-00	METAL YOKE STOP	1
13	234-5101-00	* 8 X 1/2 SLT	6
14	530-5348-00	PLUNGER, POP BUMPER	1
15	266-5047-00	COMPRESSION SPRING, POP BUMPER	1
16	545-5031-00	COIL SLEEVE	1
17	515-5939-00	COIL BRACKET POP BUMPER ASSY	1
18	545-5609-00	FIBER YOKE	1
19	535-7346-00	METAL YOKE	1
20	237-5957-00	#6-32 x 1-3/16" SPIRAL FIN SHANK SCREW	3

### 5.15 POP BUMPER TOP ASSEMBLY 515-6459-00

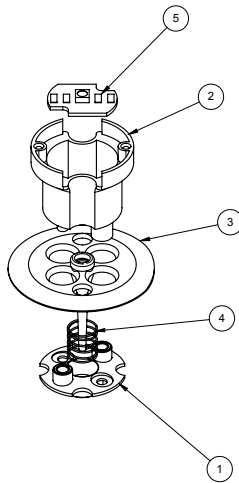

ID	Part Number	Description	Qty
1	545-5195-00	BUMPER BASE	1
2	545-5197-00	BUMPER BODY	1
3	545-5607-00	BUMPER SKIRT	1
4	266-5048-00	COMPRESSION SPRING, POP BUMPER BODY	1
5	511-7670-08	POP BUMPER LED PCB W/ WIRES	1

### 5.16 BUMPER RING TOP ASSEMBLY 515-5085-00

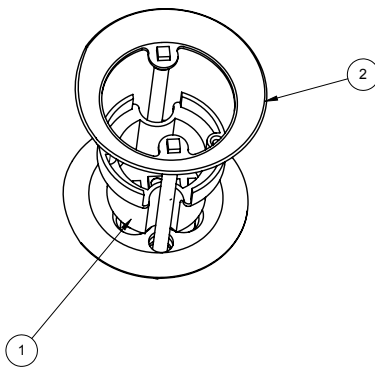

ID	Part Number	Description	Qty
1	515-6459-00	POP BUMPER TOP ASSY W/ LED	1
2	535-5874-00	RING ASSEMBLY	1

### 5.17 FIVE-BANK DROP TARGET ASSEMBLY 500-7216-15

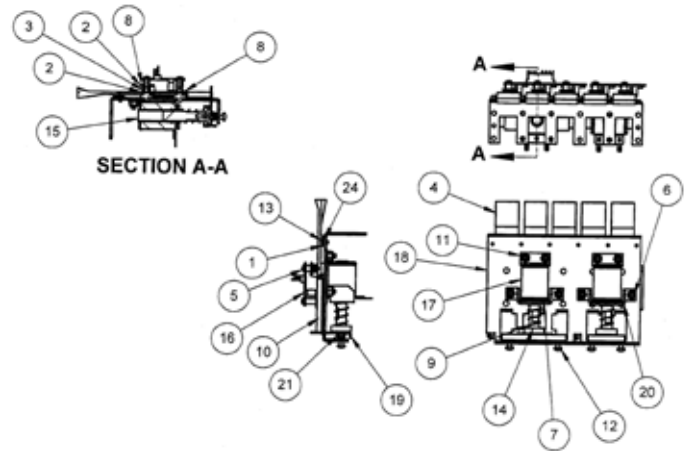

ID	Part Number	Description	Qty
1	545-6163-05	LEDGE, 5-BANK DROP TARGET	1
2	242-5091-00	WASHER, 1/2 X 17/64 X .03 - DT	15
3	266-5089-00	SPRING COMPRESSION - DT	5
4	545-6305-00	TARGET - ROLLOVER - BLACK	5
5	237-5501-00	SCREW, 6-32 X 3/8" PPH MS ZINC	10
6	240-5102-00	8-32 NYLON LOCK NUT	8
7	269-5002-00	SPRING WASHER	2
8	270-5002-00	RETAINING RING - 1/4"	10
9	266-5020-00	COMPRESSION SPRING-CONICAL	2
10	265-5003-02	TARGET RESET SPRING	5
11	535-9959-00	STOP BRKT	2
12	237-5602-00	SCREW, 8-32 X 1/2 PPH MS, ZINC	4
13	237-6169-00	SCREW, 4-40 X 1/4 PPH MS	6
14	530-5757-00	PLUNGER - D.T. ASSY.	2
15	545-5076-01	COIL SLEEVE	2
16	520-5252-03	3 BANK DROP TARGET PCB-OPTO	1
17	090-5034-ND	COIL 25-1240 - NO DIODE	2
18	515-7784-05	DROP TARGET FRAME ASSY - 5-BANK	1
19	535-9996-03	LIFT BRACKET - 3 BANK	1
20	535-9995-01	COIL BRACKET	2
21	237-5985-00	10-32 X 3/8 SHWH SWAGE SCREW	2
22	520-5252-02	2 BANK DROP TARGET PCB-OPTO	1
23	535-9996-02	LIFT BRACKET - 2 BANK	1
24	545-6798-01	SHIM - FICHE PAPER - D.T. DOUBLE	2
98*	036-5542-00	DROP TARGET CABLE	2
99*	605-5006-00	1/8" PVC TUBING	.2FT

## 5.18 VERTICAL UP-KICKER ASSEMBLY

500-7078-01

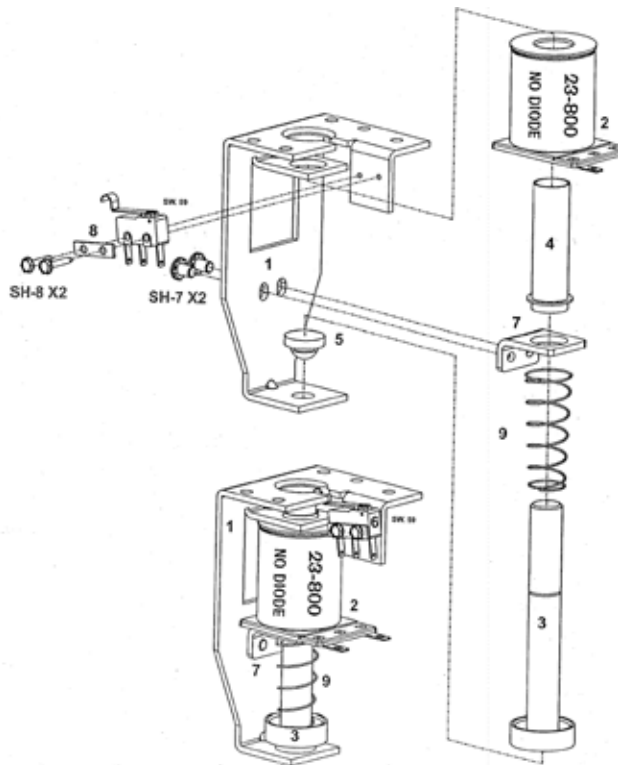

ID	Part Number	Description	Qty
1	535-9590-03	VUK BRACKET - R.H. - NO ACTUATOR	1
2	090-5001-ND	COIL - 23-800, NO DIODE	1
3	515-5941-01	PLUNGER ASSEMBLY	1
4	545-5076-01	COIL SLEEVE	1
5	545-5105-00	RUBBER BUMPER	1
6	180-5209-00	SUB MINIATURE SWITCH - SIM. ROLLER	1
7	535-5203-03	COIL RETAINING BRACKET	1
8	535-6539-00	SWITCH BODY PROTECT PLATE	1
SH-8	237-5937-02	SCREW, 2-56 X 1/2" HWH MS	2
SH-7	232-5300-00	SCREW, 8-32 X 1/4" PPH SEMS	2
9	266-5020-00	COMPRESSION SPRING-CONICAL	1

## 5.19 UP POST ASSEMBLY, LONG, NO DIODE

500-6657-04-ND

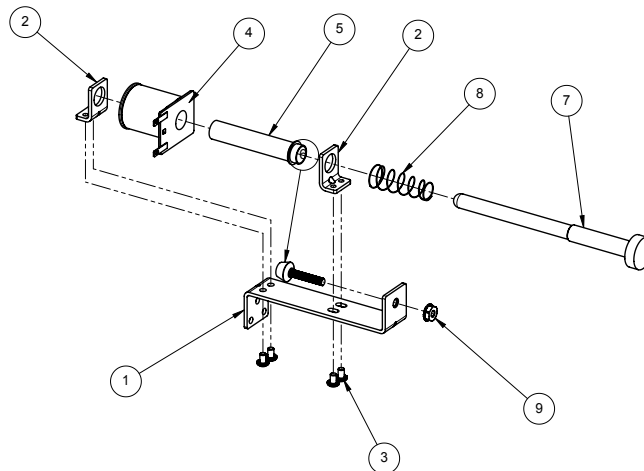

ID	Part Number	Description	Qty
1	535-9248-00	BRACKET	1
2	535-5203-03	COIL RETAINING BRACKET	2
3	232-5300-00	SCREW, 8-32 X 1/4" PPH SEMS	4
4	090-5044-ND	COIL 26-1200 - NO DIODE	1
5	545-5847-00	COIL SLEEVE	1
6	280-5014-00	ADJUSTABLE BUMPER/STOP	1
7	515-7223-00	SOLID PLUNGER ASSEMBLY	1
8	266-5022-00	COMPRESSION SPRING-CONICAL	1
9	240-5208-00	10-32 KEPS NUT	1

## 5.20 FORK RAMP OPTO ASSEMBLY 511-7834-00

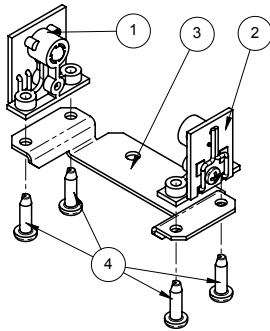

ID	Part Number	Description	Qty
1	515-0215-01	LONG RANGE OPTO RECEIVER ASSEMBLY	1
2	515-0215-00	LONG RANGE OPTO EMITTER ASSEMBLY	1
3	535-1512-00	CLEAVER OPTO BRACKET	1
4	237-5880-02	SCREW, #6 X 1/2 PPH T-25	4

## 5.21 SPINNER ASSEMBLY, BALL GUIDE MOUNT 511-7877-00

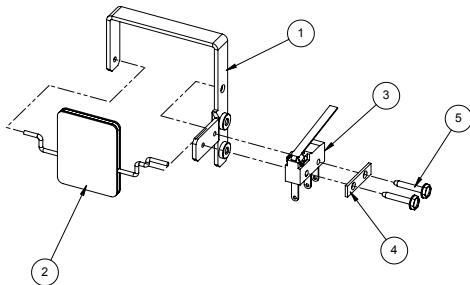

ID	Part Number	Description	Qty
1	535-1591-00	SPINNER BRACKET, BALL GUIDE MNT	1
2	515-7088-00	SPINNER TARGET, NARROW	1
3	180-5010-04	MICRO-SWITCH	1
4	535-6539-00	SWITCH BODY PROTECT PLATE	1
5	237-5937-02	SCREW, 2-56 X 1/2" HWH MS	2

## 5.22 FORK RAMP ASSEMBLY - MOTORIZED 500-1045-01

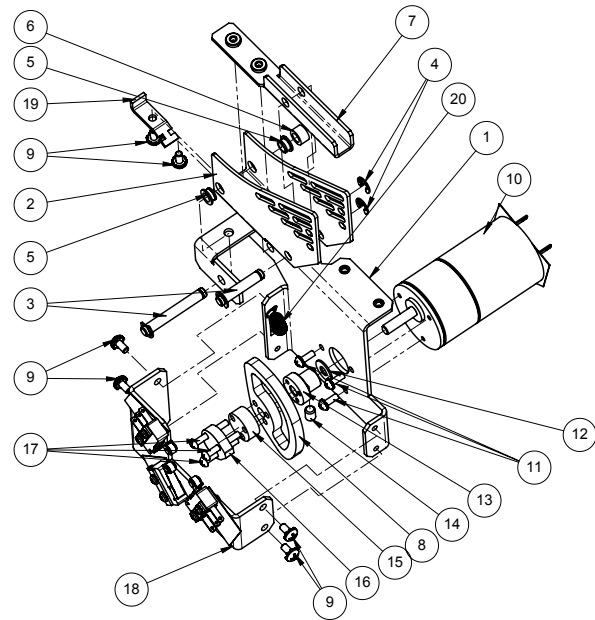

ID	Part Number	Description	Qty
1	515-9976-01	FORK RAMP MOUNT	1
2	535-1510-00	FORK RAMP	1
3	530-7812-11	PIVOT PIN-.188 DIA.	2
4	270-5001-00	RETAINING E-RING, 3/16" SHAFT OD	4
5	545-5352-00	NYLINER, 3/16" SHAFT	2
6	254-5093-02	SPACER, .188 X .192 ID X 5/16 OD	1
7	515-1836-00	CAM FOLLOWER	1
8	545-9974-00	CLEAVER ACTUATOR CAM	1
9	232-5200-00	SCREW, 6-32 X 1/4" PPH SEMS	6
10	511-7926-00	MOTOR ASSEMBLY	1
11	237-5882-00	SCREW, #4-40 X 5/16 PRH SEMS	3
12	242-5088-00	NYLON WASHER .195" X .437" X .031"	1
13	530-7964-00	HUB	1
14	237-6310-00	SET SCREW, 10-32 X 1/4", SOCKET CUP PT	1
15	545-9973-00	CAM SPACER	1
16	535-1649-00	SWITCH CAM	1
17	237-5863-00	SCREW, 4-40 X 3/4 PRH	3
18	511-7913-00	SWITCH BRACKET ASSEMBLY	1
19	535-1656-00	CLIP - SPRING RETAINER	1
20	265-5001-00	RESET ARMATURE SPRING	1

## 5.23 TIE FIGHTER SPRING ASSEMBLY

500-1065-00

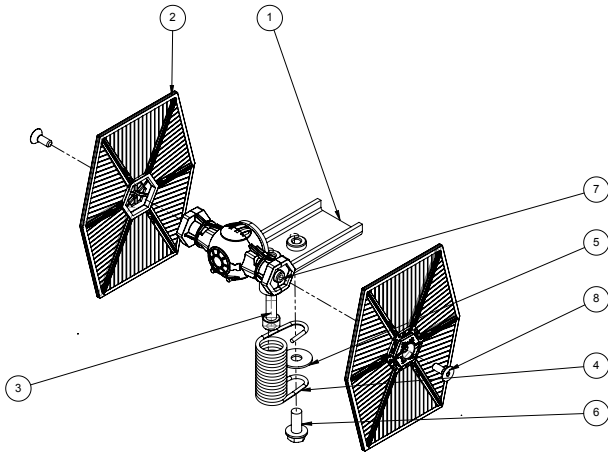

ID	Part Number	Description	Qty
1	515-1900-00	TIE FIGHTER CHASSIS ASSEMBLY	1
2	880-6203-00	TIE FIGHTER WING	2
3	237-6132-00	8-32 x 1/2 LG. SOC HD HEX, BLACK OXIDE	1
4	266-5107-02	ONE SIDED BUCKLING SPRING	1
5	242-5015-00	#8 WASHER - .170 ID X 1/2 OD X .042	1
6	237-5879-00	#8-32 X 3/8 HWH ZINC	1
7	530-7965-00	#8 SPACER, STAINLESS STEEL	1
8	237-6338-00	4-40 X 5/16 LG FH HX, BLACK OXIDE	2

## 5.24 TIE FIGHTER POST ASSEMBLY

500-1076-00

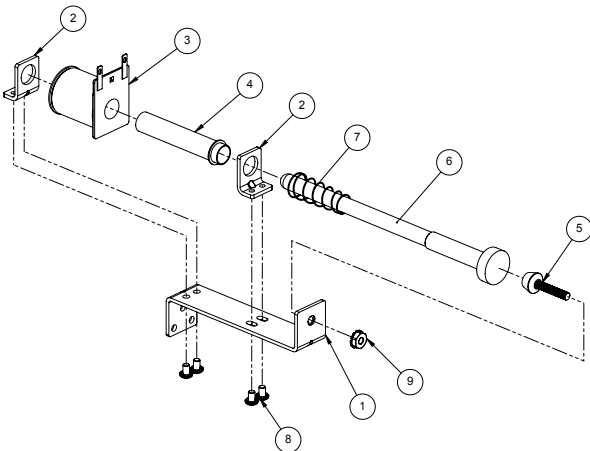

ID	Part Number	Description	Qty
1	535-9248-00	BRACKET	1
2	535-5203-03	COIL RETAINING BRACKET	2
3	090-5044-ND	COIL 26-1200 - NO DIODE	1
4	545-5847-00	COIL SLEEVE	1
5	280-5014-00	ADJUSTABLE BUMPER/STOP	1
6	515-1838-00	.375 DIA TIP PLUNGER ASSEMBLY	1
7	266-5020-00	COMPRESSION SPRING-CONICAL	1
8	232-5300-00	SCREW, 8-32 X 1/4" PPH SEMS	4
9	240-5208-00	10-32 KEPS NUT	1

## 5.25 STAR WARS LE SPOT LAMP ASSEMBLY

500-1091-00

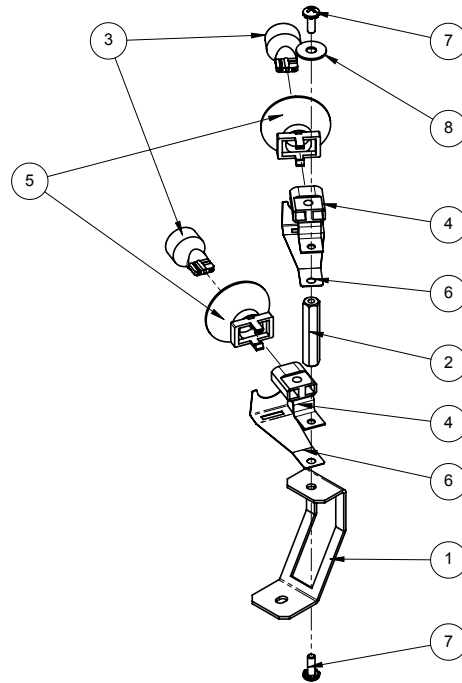

ID	Part Number	Description	Qty
1	535-1736-00	SPOTLIGHT BRACKET	1
2	254-5008-11	HEX SPACER - 1 1/4 "	1
3	113-5032-08	8 ELEMENT FLAT W-BASE LED 5V AC - WHITE	2
4	077-5026-01	SOCKET, L/D WEDGE BASE BLACK	2
5	545-5409-01	REFLECTOR	2
6	535-1324-01	W.B. LED SPOTLAMP RETAINER CLIP	2
7	232-5201-00	SCREW, 6-32 X 3/8" PPH MS SEMS	2
8	242-5015-00	#8 WASHER - .170 ID X 1/2 OD X .042	1



### 5.26 LCD DISPLAY ASSEMBLY 500-2465-00

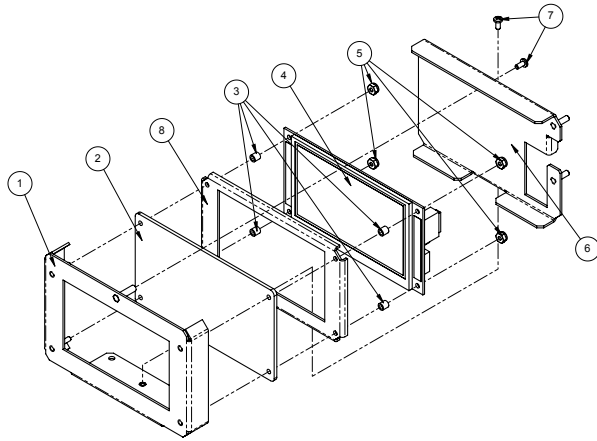

ID	Part Number	Description	Qty
1	515-1819-00	LCD DISPLAY, 4.3", FRONT BRKT	1
2	545-9951-00	LCD DISPLAY, 4.3", SCREEN PROTECTOR	1
3	254-5090-01	PLASTIC SPACER #4 SCREW, 3/16" OD - 3/16" LENGTH	4
4	509-2002-00	4.3" LCD FOR DONUT	1
5	240-5303-00	4-40 NYLON LOCK NUT	4
6	535-1592-00	LCD DISPLAY, 4.3", BACK BRKT	1
7	237-6331-00	SCREW, 4-40 X 1/4" PPH MS BLACK	2
8	535-1696-00	LCD DISPLAY, 4.3", SCREEN PROTECTOR SUPPORT	1

### 5.27 LCD DISPLAY HDMI CABLE ASSEMBLY 500-2465-J6

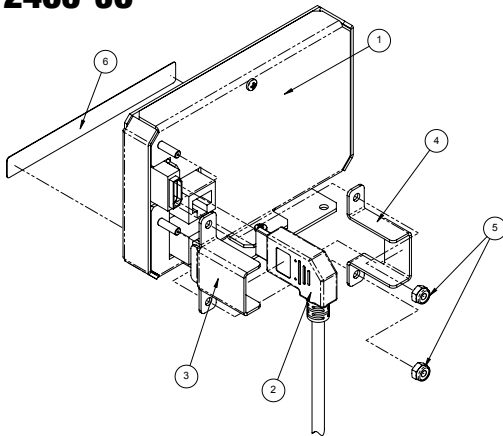

ID	Part Number	Description	Qty
1	500-2465-00	LCD DISPLAY, 4.3", ASSY	1
2	604-5500-02	HDMI CABLE LEFT M/M 6 FT	1
3	535-1730-00	HDMI CABLE PROTECTOR LEFT	1
4	535-1731-00	HDMI CABLE PROTECTOR RIGHT	1
5	240-5005-00	6-32 NYLON STOP NUT	2
6	820-8422-18	DECAL SET -18	1

### 5.28 UP POST ASSEMBLY - LONG NO DIODE 500-6657-04-ND

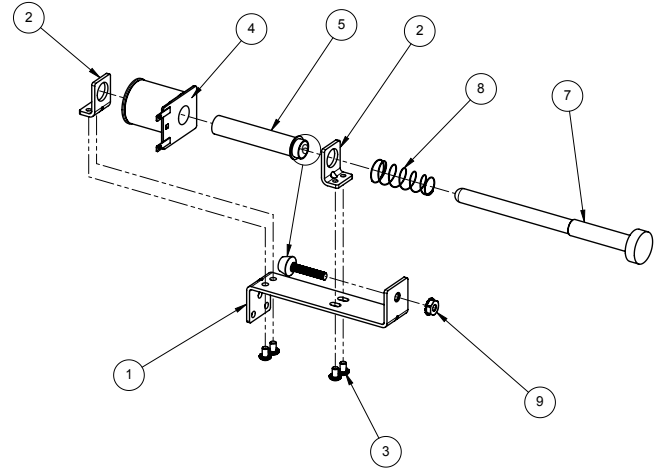

ID	Part Number	Description	Qty
1	535-9248-00	BRACKET	1
2	535-5203-03	COIL RETAINING BRACKET	2
3	232-5300-00	SCREW, 8-32 X 1/4" PPH SEMS	4
4	090-5044-ND	COIL 26-1200 - NO DIODE	1
5	545-5847-00	COIL SLEEVE	1
6	280-5014-00	ADJUSTABLE BUMPER/STOP	1
7	515-7223-00	SOLID PLUNGER ASSEMBLY	1
8	266-5022-00	COMPRESSION SPRING-CONICAL	1
9	240-5208-00	10-32 KEPS NUT	1

### 5.29 VUK WITH SPACER ASSEMBLY 500-1078-XX

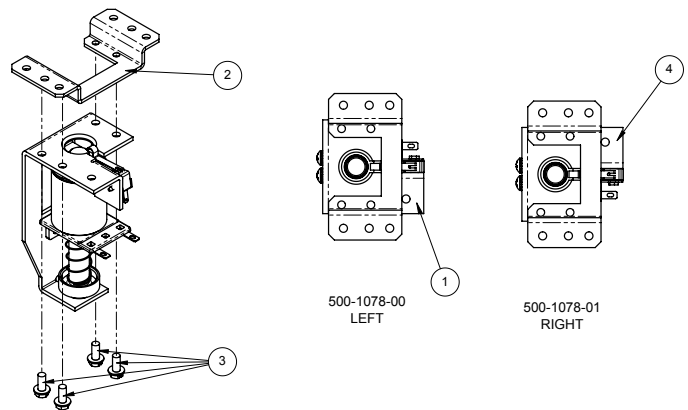

ID	Part Number	Description	500-1078-00/ Qty	500-1078-01/ Qty
1	500-7078-00	V.U.K. ASSEMBLY - W/O ACTUATOR - L.H.	1	-
2	535-1685-00	VUK SPACER	1	1
3	237-5975-00	SCREW, 8-32 X 3/8" HWH SWAGE ZN	4	4
4	500-7078-01	V.U.K. ASSEMBLY - W/O ACTUATOR - R.H.	-	1

## 5.30 MILLENNIUM FALCON SHIP SUBASSEMBLY

511-7887-00

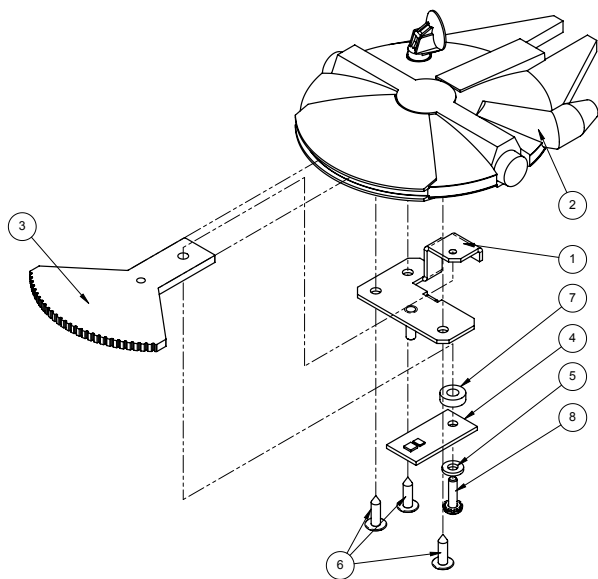

ID	Part Number	Description	Qty
1	535-1638-00	FALCON LIGHT SUPPORT BRACKET	1
2	515-1871-00	FALCON TOY ASSEMBLY	1
3	545-1019-00	FALCON ENGINE PLASTIC	1
4	520-7000-00	SINGLE FLASH LED BOARD	1
5	242-5079-00	WASHER, .150 I.D. X .312 O.D. X .050 THICK	1
6	237-5809-00	SCREW, #6 X 1/2" PTH A	3
7	254-5000-19	NYLON SPACER - BLACK - 3/8 OD X .175 ID X 1/8"	1
8	232-5202-00	SCREW, 6-32 X 1/2" PPH MS SEMS	1

## 5.31 COMPACT DIVERTER ASSEMBLY

500-1046-00

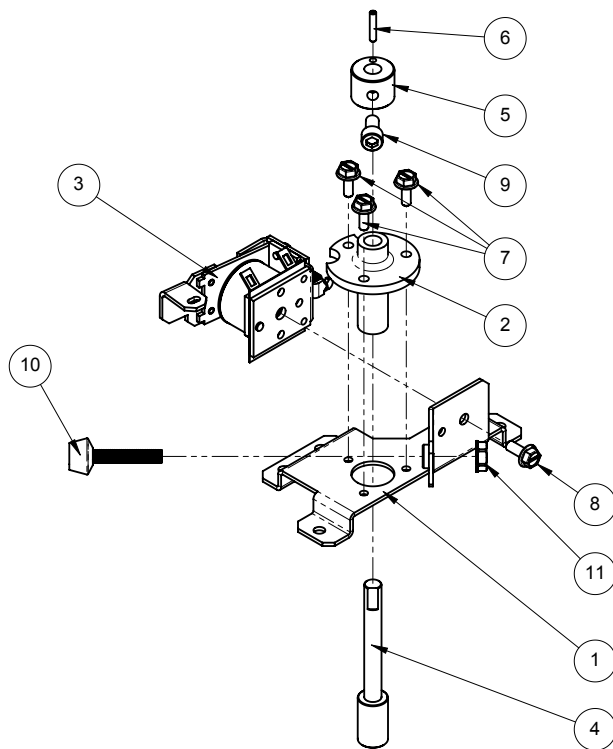

ID	Part Number	Description	Qty
1	535-1527-00	COMPACT DIVERTER BRACKET	1
2	545-5070-00	FLIPPER BUSHING	1
3	515-9980-ND	COIL ASSEMBLY, COMPACT DIVERTER	1
4	530-7956-00	COMPACT DIVERTER SHAFT, SM	1
5	530-7948-00	COMPACT DIVERTER COLLAR	1
6	251-5002-00	ROLL PIN - 3/32" DIA X 1/2 " LG	1
7	237-5976-02	SCREW, 6-32 X 3/8" HWH SWAGE	3
8	237-5903-00	SCREW, 8-32 X 3/8" HWH	1
9	237-5845-00	SCREW, 10-32 X 3/8" SHCS ZINC	1
10	280-5014-00	ADJUSTABLE BUMPER/STOP	1
11	240-5208-00	10-32 KEPS NUT	1

## 5.32 STAR WARS LE LEFT RAMP ASSEMBLY

500-1023-01

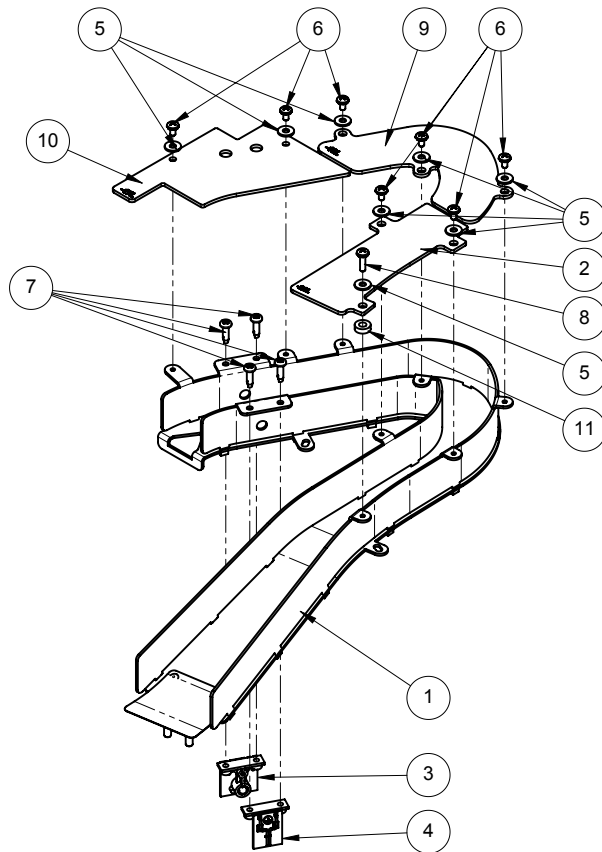

ID	Part Number	Description	Qty
1	510-7685-01	DOUNT LE LEFT RAMP RIVETED ASSEMBLY	1
2	830-8400-22L	PLASTIC SET -22L	1
3	515-0215-01	LONG RANGE OPTO RECEIVER ASSEMBLY	1
4	515-0215-00	LONG RANGE OPTO EMITTER ASSEMBLY	1
5	242-5001-00	#6 WASHER	8
6	232-5200-00	SCREW, 6-32 X 1/4" PPH SEMS	7
7	237-5880-02	SCREW, #6 X 1/2 PPH T-25	4
8	232-5202-00	SCREW, 6-32 X 1/2" PPH MS SEMS	1
9	830-8400-19L	PLASTIC SET -19L	1
10	830-8400-17L	PLASTIC SET -17L	1
11	254-5000-19	NYLON SPACER - BLACK - 3/8 OD X .175 ID X 1/8"	1

## 5.33 STAR WARS LE RIGHT RAMP ASSEMBLY

500-1024-01

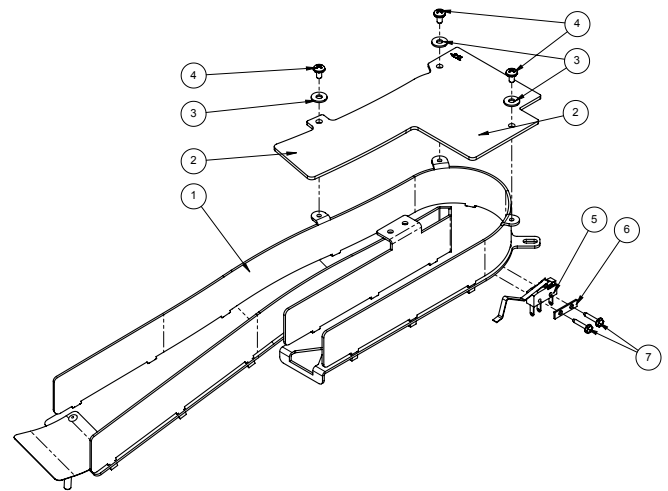

ID	Part Number	Description	Qty
1	510-7686-01	DONUT LE RIGHT RAMP RIVETED ASSEMBLY	1
2	830-8400-21L	PLASTIC SET -21L	1
3	242-5001-00	#6 WASHER	3
4	232-5200-00	SCREW, 6-32 X 1/4" PPH SEMS	3
5	180-5057-00	MICRO-SWITCH	1
6	535-6539-00	SWITCH BODY PROTECT PLATE	1
7	237-5937-02	SCREW, 2-56 X 1/2" HWH MS	2

### 5.34 DEATH STAR LE MAIN ASSEMBLY

500-1062-00

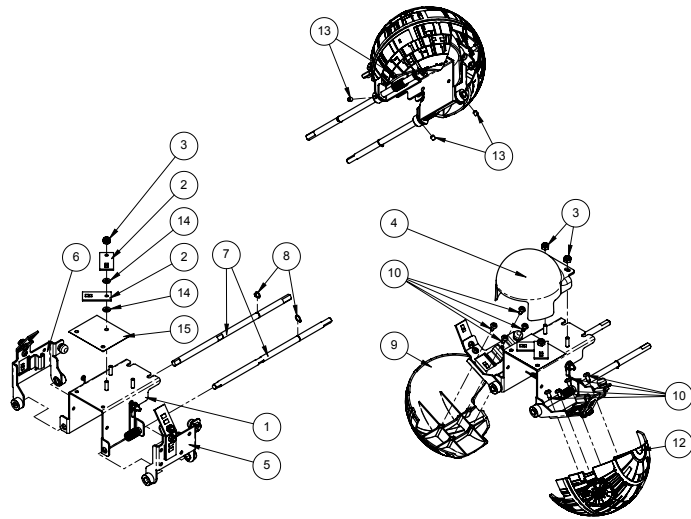

ID	Part Number	Description	Qty
1	511-7918-00	DEATH STAR LE FRAME SUB ASSEMBLY	1
2	520-7000-00	SINGLE FLASH LED BOARD	2
3	240-5005-00	6-32 NYLON STOP NUT	3
4	545-1017-00	FIRE BALL VACUUM FORMED	1
5	511-7897-00	DEATH STAR LIGHT SUBASSEMBLY	1
6	511-7897-01	DEATH STAR LIGHT SUBASSEMBLY	1
7	530-7971-00	DEATH STAR SHAFT	2
8	270-5410-00	EXTERNAL RETAINING RING, 1/4" O.D. SHAFT	2
9	550-7411-00	DEATH STAR LEFT	1
10	237-5880-01	SCREW, #6 X 5/16 PPH T-25	7
11	237-5880-01	SCREW, #6 X 5/16 PPH T-25	1
12	511-7917-00	DEATH STAR LE RIGHT ASSEMBLY	1
13	237-6153-00	8-32 X 3/16 SOCKET HEX SET SCREW	4
14	242-5079-00	WASHER, .150 I.D. X .312 O.D. X .050 THICK	2
15	523-0006-00	DEATH STAR FISH PAPER	1

### 5.35 DEATH STAR LE RIGHT ASSEMBLY

511-7917-00

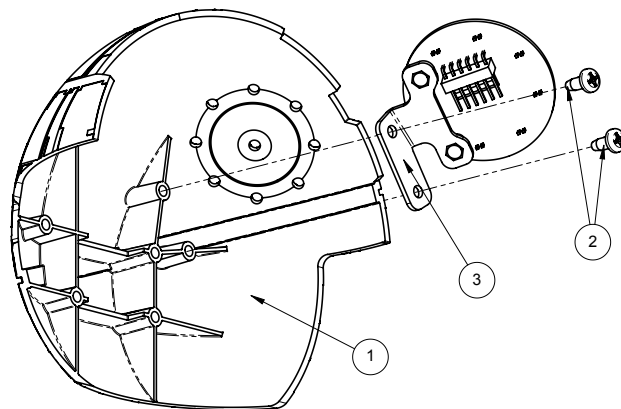

ID	Part Number	Description	Qty
1	550-7412-00	DEATH STAR RIGHT	1
2	237-5880-01	SCREW, #6 X 5/16 PPH T-25	2
3	511-9972-00	SUPERLASER ASSEMBLY	1

### 5.36 DEATH STAR LE FRAME ASSEMBLY

511-7918-00

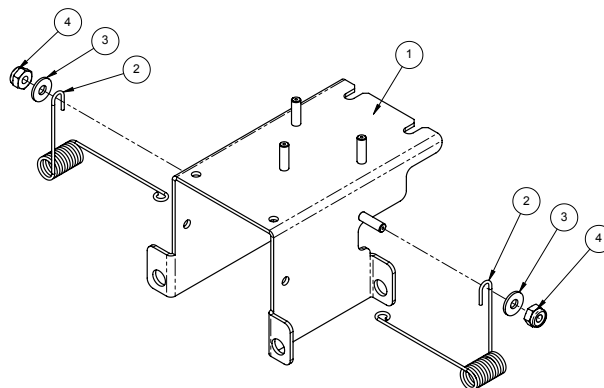

ID	Part Number	Description	Qty
1	515-9991-00	DEATH STAR MOUNT	1
2	267-5011-01	DEATH STAR TORSION SPRING	2
3	242-5001-00	#6 WASHER	2
4	240-5005-00	6-32 NYLON STOP NUT	2

## 5.37 DEATH STAR ACTUATOR ASSEMBLY

511-7890-00

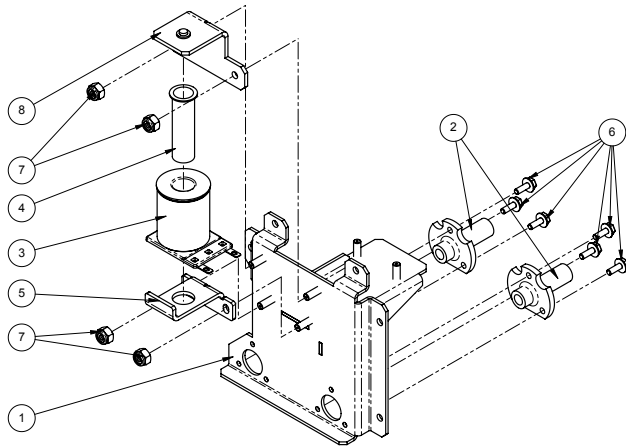

ID	Part Number	Description	Qty
1	515-1821-00	DEATH STAR ACTUATOR MAIN PLATE	1
2	545-5070-08	FLIPPER BUSHING	2
3	090-5044-ND	COIL 26-1200 - NO DIODE	1
4	545-5411-00	COIL SLEEVE	1
5	535-5203-05	COIL RETAINING BRACKET	1
6	237-5976-02	SCREW, 6-32 X 3/8" HWH SWAGE	6
7	240-5102-00	8-32 NYLON LOCK NUT	4
8	515-1832-00	DEATH STAR ACTUATOR COIL MOUNT	1

## 5.38 DEATH STAR LINKAGE ASSEMBLY

511-1068-00

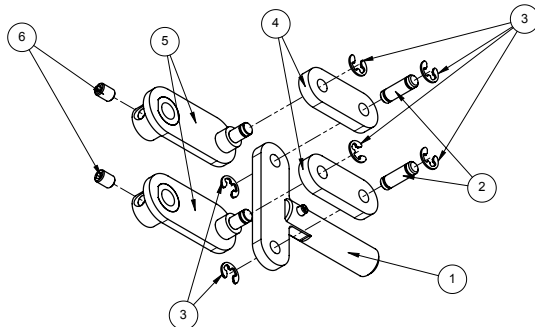

ID	Part Number	Description	Qty
1	515-9768-05	PLUNGER / LINK ASSEMBLY	1
2	530-7812-06	PIVOT PIN-.188 DIA.	2
3	270-5001-00	RETAINING E-RING, 3/16" SHAFT OD	6
4	545-7887-06	DRIVE LINKAGE-NYLON	2
5	515-9916-00	DEATH STAR CRANK ARM	2
6	237-6310-00	SET SCREW, 10-32 X 1/4", SOCKET CUP PT	2

## 5.39 DEATH STAR LIGHT ASSEMBLY 511-7897-XX

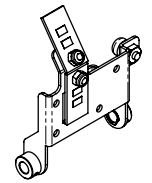
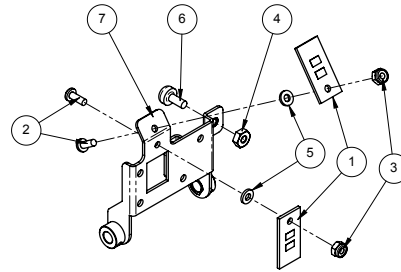

511-7897-00 "LEFT"

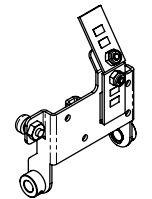

511-7897-01 "RIGHT"

ID	Part Number	Description	511-7897-00/ Qty	511-7897-01/ Qty
1	520-7000-00	SINGLE FLASH LED BOARD	2	2
2	237-6322-00	SCREW, 6-32 X 3/8" PPH MS ZINC, BLACK	2	2
3	240-5005-00	6-32 NYLON STOP NUT	2	2
4	240-5103-00	#8 HEX NUT	1	1
5	242-5079-00	WASHER, .150 I.D. X .312 O.D. X .050 THICK	2	2
6	280-5029-01	THREADED BUMPER, 8-32 THREAD	1	1
7	515-1820-00	DEATH STAR SUPPORT BRACKET, LEFT	1	-
7	515-1820-01	DEATH STAR SUPPORT BRACKET, RIGHT	-	1

## 5.40 ELECTRIC GATE RAIL MOUNT ASSEMBLY

511-5033-XX

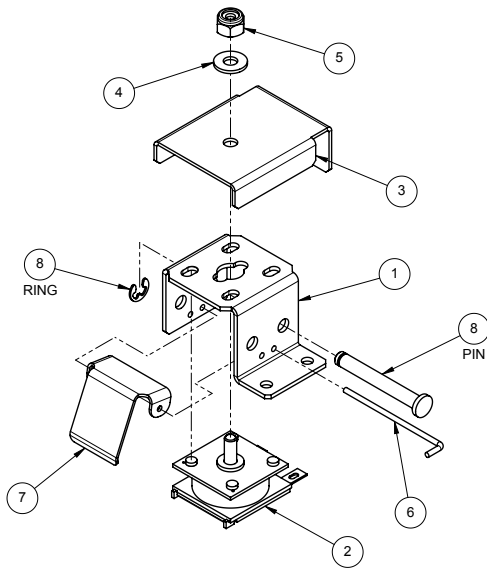

ID	Part Number	Description	Qty
1	535-9847-00	BRACKET, ELEC GATE, RAIL MOUNT	1
2	090-5060-01-ND	MINI-COIL W/CORE, ND - 32-1250, YELLOW	1
3	535-9577-00	COVER, ELECTRIC GATE	1
4	242-5005-00	#8 WASHER	1
5	240-5102-00	8-32 NYLON LOCK NUT	1
6	535-5372-00	REBOUND HINGE PIN	1
7	535-9682-00	GATE - ELECTRIC (MAGNET)	1
8	530-5702-01	CLEVIS PIN W/ RING, 3/16"D X 1-1/2"	1

## 5.41 STAR WARS LE WIRE RAMP ASSEMBLY

511-7807-01

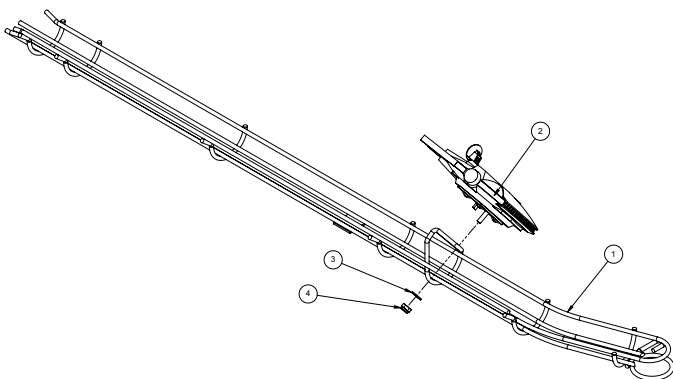

ID	Part Number	Description	Qty
1	535-1468-01	DOUGHNUT LEFT WIRE RAMP	1
2	511-7887-00	FALCON SHIP SUBASSEMBLY	1
3	242-5001-00	#6 WASHER	1
4	240-5005-00	6-32 NYLON STOP NUT	1

## 5.42 ELECTRIC GATE BACK PANEL MOUNT

511-5096-XX

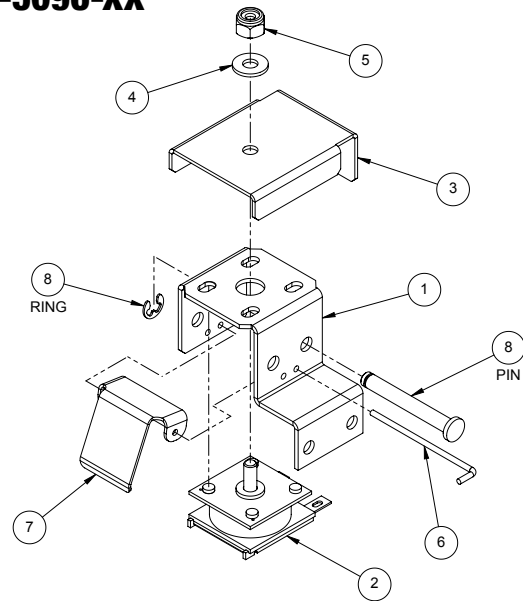

ID	Part Number	Description	Qty
1	535-0134-00	BRACKET, ELEC GATE, BK. PANEL MNT	1
2	090-5060-01-ND	MINI-COIL W/CORE, ND - 32-1250, YELLOW	1
3	535-9577-00	COVER, ELECTRIC GATE	1
4	242-5005-00	#8 WASHER	1
5	240-5102-00	8-32 NYLON LOCK NUT	1
6	535-5372-00	REBOUND HINGE PIN	1
7	535-9682-00	GATE - ELECTRIC (MAGNET)	1
8	530-5702-01	CLEVIS PIN W/ RING, 3/16"D X 1-1/2"	1

## 5.43 ORBIT OPTO ASSEMBLY

511-7893-00

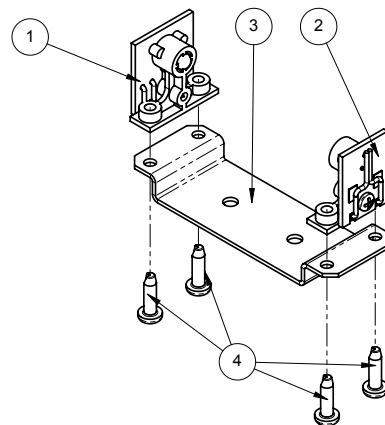

ID	Part Number	Description	Qty
1	515-0215-01	LONG RANGE OPTO RECEIVER ASSEMBLY	1
2	515-0215-00	LONG RANGE OPTO EMITTER ASSEMBLY	1
3	535-1613-00	OPTO BRACKET	1
4	237-5880-02	SCREW, #6 X 1/2 PPH T-25	4

### 5.44 BALL GUIDE 01 ASSEMBLY 511-7797-01

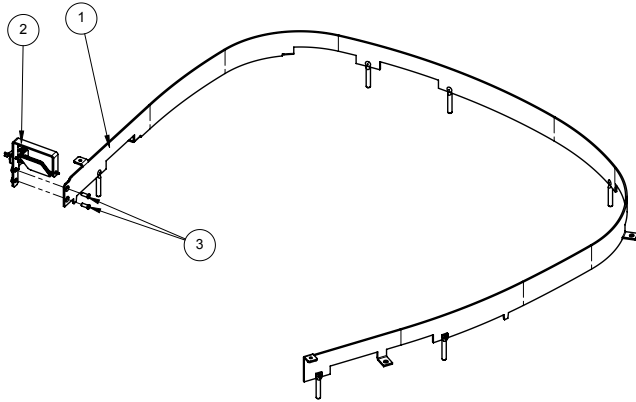

ID	Part Number	Description	Qty
1	535-1456-01	DOUGHNUT BALL GUIDE -01	1
2	511-7877-00	SPINNER ASSY, BALL GUIDE MNT	1
3	237-6151-00	SCREW, 4-40 X 5/16" PFH U/C MS	2

### 5.46 PLASTIC 12L ASSEMBLY 511-7798-12L

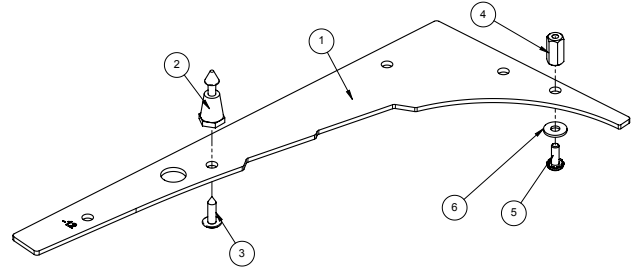

ID	Part Number	Description	Qty
1	830-7378-12L	PLASTIC SET -12L	1
2	550-5052-01	MINI POST - CLEAR	1
3	237-5809-00	SCREW, #6 X 1/2" PTH A	1
4	254-5008-03	HEX SPACER - 1/2 "	1
5	232-5201-00	SCREW, 6-32 X 3/8" PPH MS SEMS	1
6	242-5001-00	#6 WASHER	1

### 5.45 PLASTIC 08L ASSEMBLY 511-7798-08L

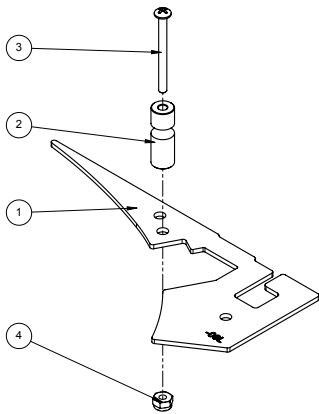

ID	Part Number	Description	Qty
1	830-7378-08L	PLASTIC SET -08L	1
2	550-5059-01	PLASTIC POST - CLEAR	1
3	237-5510-00	SCREW, 6-32 X 1-1/2" PPH MS	1
4	240-5005-00	6-32 NYLON STOP NUT	1

### 5.47 PLASTIC 20L ASSEMBLY 511-7798-20L

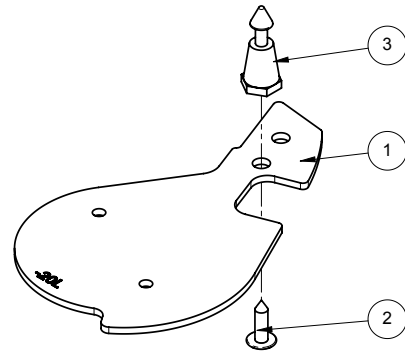

ID	Part Number	Description	Qty
1	830-7378-20L	PLASTIC SET -20L	1
2	237-5809-00	SCREW, #6 X 1/2" PTH A	1
3	550-5052-01	MINI POST - CLEAR	1

### 5.48 ACCELERATOR EXIT DIVERTER ACTUATOR ASSEMBLY

500-1063-00

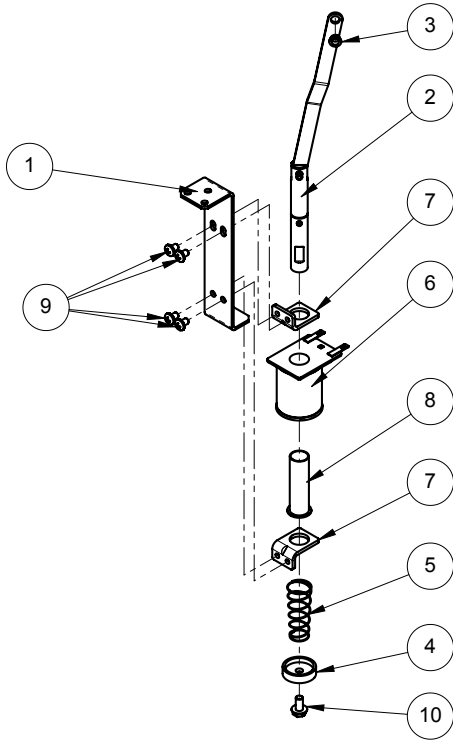

ID	Part Number	Description	Qty
1	535-1609-00	ACCELERATOR EXIT DIVERTER ACTUATOR BRACKET	1
2	515-9993-00	ACCELERATOR EXIT DIVERTER ACTUATOR CONTROL ARM ASSY	1
3	545-5352-00	NYLINER, 3/16" SHAFT	1
4	530-5511-01	SHAFT HEAD	1
5	266-5020-00	COMPRESSION SPRING-CONICAL	1
6	090-5044-ND	COIL 26-1200 - NO DIODE	1
7	535-5203-03	COIL RETAINING BRACKET	2
8	545-5411-00	COIL SLEEVE	1
9	232-5300-00	SCREW, 8-32 X 1/4" PPH SEMS	4
10	237-5961-00	SCREW, 10-32 X 3/8" HWH	1

### 5.49 ACCELERATOR EXIT DIVERTER ASSEMBLY

500-1064-00

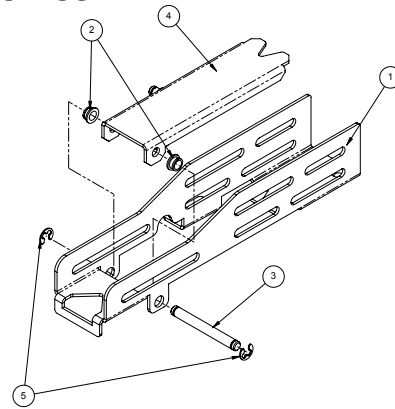

ID	Part Number	Description	Qty
1	515-1826-00	ACCELERATOR EXIT DIVERTER EXIT EXTENSION	1
2	545-5352-00	NYLINER, 3/16" SHAFT	2
3	530-7812-18	PIVOT PIN-.188 DIA.	1
4	515-1827-00	ACCELERATOR EXIT DIVERTER FLOOR	1
5	270-5001-00	RETAINING E-RING, 3/16" SHAFT OD	2

### 5.50 ACCELERATOR ASSEMBLY

511-7816-00

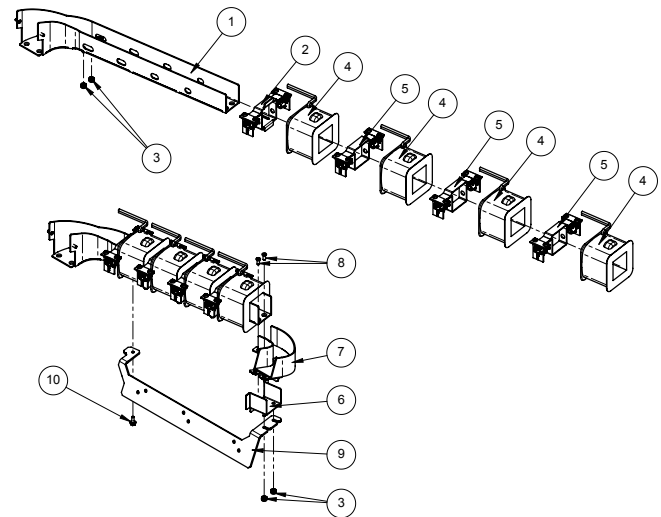

ID	Part Number	Description	Qty
1	515-9967-00	ACCELERATOR TUBE	1
2	511-7817-00	ACCELERATOR COIL SPACER ASSEMBLY	1
3	240-5005-00	6-32 NYLON STOP NUT	4
4	090-5086-00	ACCELERATOR COIL	4
5	511-7818-00	ACCELERATOR COIL SPACER ASSEMBLY	3
6	535-1501-00	ACCELERATOR RAMP EXIT MOUNT	1
7	515-9968-00	ACCELERATOR EXIT	1
8	237-5850-00	SCREW, 6-32 x 3/8 PFH ZINC	2
9	535-1502-00	ACCELERATOR ASSEMBLY MOUNT	1
10	237-5976-02	SCREW, 6-32 X 3/8" HWH SWAGE	1



## 5.51 ACCELERATOR COIL SPACER ASSEMBLY

511-7817-00

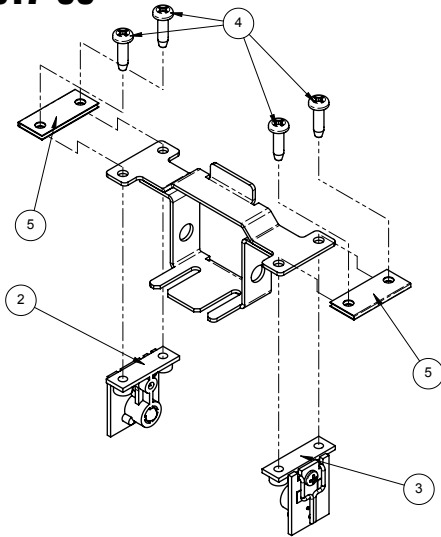

ID	Part Number	Description	Qty
1	535-1499-00	ACCELERATOR COIL SPACER	1
2	515-0215-00	LONG RANGE OPTO RECEIVER ASSEMBLY	1
3	515-0215-01	LONG RANGE OPTO EMITTER ASSEMBLY	1
4	237-5880-02	SCREW, #6 X 1/2 PPH T-25	4
5	523-0005-00	ACCELERATOR OPTO PROTECTOR	2

## 5.52 ACCELERATOR COIL SPACER ASSEMBLY

511-7818-00

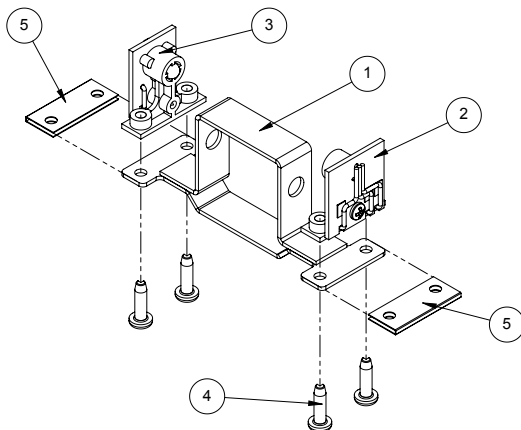

ID	Part Number	Description	Qty
1	535-1500-00	ACCELERATOR COIL SPACER	1
2	515-0215-01	LONG RANGE OPTO RECEIVER ASSEMBLY	1
3	515-0215-00	LONG RANGE OPTO EMITTER ASSEMBLY	1
4	237-5880-02	SCREW, #6 X 1/2 PPH T-25	4
5	523-0005-00	ACCELERATOR OPTO PROTECTOR	2

## 5.53 STAR WARS LE BACK PANEL ASSEMBLY

500-1022-01

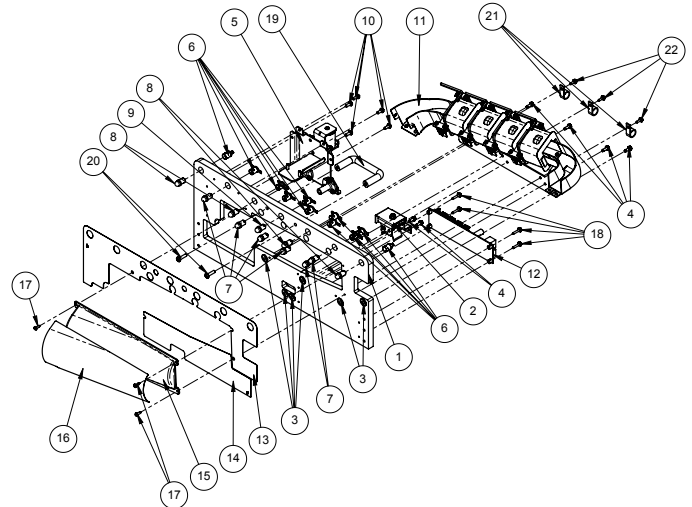

ID	Part Number	Description	Qty
1	525-9706-01	BACK PANEL, DOUGHNUT LE	1
2	511-5096-00	ASSY, ELEC GATE LEFT, BP MT	1
3	240-5101-00	8-32 T-NUT	6
4	237-5975-01	SCREW, 8-32 x 1/2 HWH SLOT SERR SW ZINC	6
5	511-7890-00	DEATH STAR ACTUATOR	1
6	077-5000-00	SOCKET - STAPLED - 2 LUGS	11
7	112-5034-05	DOUBLE LED, BAYONET BASE - BLUE	6
8	112-5034-08	DOUBLE LED, BAYONET BASE - CLEAR	4
9	112-5034-02	DOUBLE LED, BAYONET BASE - RED	1
10	234-5101-00	SCREW, #8 X 1/2" SLT HWH AB ZINC	5
11	511-7816-00	ACCELERATOR ASSEMBLY	1
12	520-6998-72	PCB, 4-COIL NODE BOARD	1
13	820-8422-15	DECAL SET -15	1
14	820-8422-14	DECAL SET -14	1
15	545-1016-00	ACCELERATOR COVER	1
16	820-8422-16	DECAL SET -16	1
17	237-5805-00	SCREW, #6 X 1/2" PPH AB BLACK	3
18	234-5003-00	SCREW, #6 X 3/4" HWH	4
19	535-1757-00	BACKPANEL HANDLE, ALUMINUM, BLACK	1
20	237-5704-01	SCREW, 10-32 X 3/4 PPH MS, BLACK	2
21	040-5000-06	1/2" CABLE CLAMP	3
22	234-5001-02	SCREW, #6 X 1/2" HWH	3

# 6. SPECIFICATIONS

500-55J6-01

## SPECIFICATIONS, MECHANICAL, GAME SETUP

Specification	Imperial	Metric
Weight	210 lbs	96 kg
Max dimensions, leg levers extended (h, w, d)	78 x 27.75 x 57 in	198 x 70.5 x 145 cm
Minimum game dimensions (h, w, d)	76 x 27.75 x 57 in	193 x 70.5 x 145 cm
Minimum room dimensions per game (h, w, d)	80 x 36 x 84 in	203 x 91 cm x 214 cm

• (h, w, d) = height, width, depth.

## SPECIFICATIONS, MECHANICAL, BOXED

Specification	Imperial	Metric
Weight, boxed (without pallet)	230 lbs	105 kg
Box dimensions (h, w, d)	56.5 x 31 x 31 in	144 x 79 x 79 cm
Minimum dimensions (h, w, d)	76 x 26 x 57 in	193 x 66 x 145 cm

• (h, w, d) = height, width, depth.

## SPECIFICATIONS, ELECTRICAL

Specification	North America - 120VAC	International - 240VAC
Line Voltage, Nominal	120 VAC	240 VAC
Line Voltage Range	90 VAC - 250 VAC	90 VAC - 250 VAC
Line Frequency *	60 Hz	50 Hz, 60 Hz
Line Power, Current - attract mode	70 W, 0.6 A @ 120 VAC	70 W, 0.3 A @ 240 VAC
Line Power, Current - nominal	360 W, 3 A @ 120 VAC	360 W, 1.5 A @ 240 VAC
Line Power, Current - peak, <100 ms	540 W, 4.5 A @ 120 VAC	540 W, 2.25 A @ 240 VAC

\* NOTE: Games designed for 60hz operation (e.g. North America games) will not function correctly on 50hz power and vice versa.

**WARNING:** Overloading electrical supply circuits is dangerous. Do not overload circuits. To calculate the maximum number of games for a circuit, check circuit amperage rating and divide by the game Nominal Line Power Current rating for your line voltage. For example, a 15A 120V household circuit, 15/3 A (nominal current) = 5 games maximum.

## SPECIFICATIONS, ENVIRONMENT

	Minimum	Maximum
Temperature, Operating	32 °F / 0 °C	104°F / 40 °C
Temperature, Storage	32 °F / 0 °C	104°F / 40 °C
Relative Humidity, Operating	5%	95% non-condensing
Relative Humidity, Storage	5%	95% non-condensing

- (a) "The appliance has to be placed in a horizontal position."
- (b) "This appliance is not to be cleaned by a Water Jet."
- (i) "Do not locate this appliance in an area where a Water Jet is used."
- (ii) "Do not clean this appliance with a Water Jet."
- (b) If the supply cord is damaged, it must be replaced in order to avoid a hazard.

## 6.1 GAME DIMENSIONS

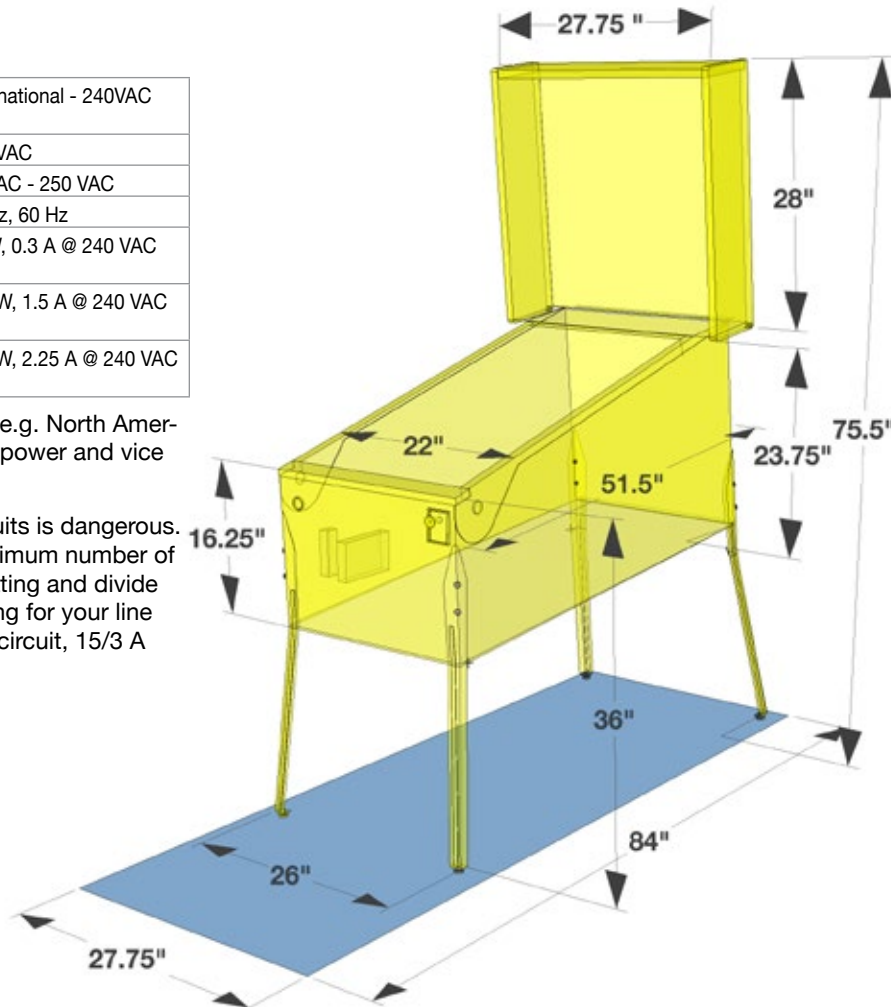

## 6.2 WARRANTY

500-55J6-01

Stern Pinball machines are assembled in Elk Grove Village, Illinois, USA; each pinball machine has unique characteristics that make it a one-of-a-kind American-made product. Each machine will have variations in appearance resulting from differences in the machine's particular wood parts, individual silk screened art and mechanical assemblies. Stern Pinball has inspected each game element to insure it meets stringent quality and playability standards.

### STERN PINBALL INC LIMITED WARRANTY

Stern Pinball Inc ("SELLER") warrants only to the initial purchaser of its products that the items listed below are free from defects in material and workmanship under normal use and service for the warranty period specified:

- Printed circuit boards (game logic): 2 months
- Dot Matrix Display boards: 9 months

No other parts of seller's product are warranted.

Warranty periods are effective from the initial date of shipment from seller to its authorized distributors.

Seller's sole liability shall be, at its option, to repair or replace products which are returned to seller during the warranty periods specified, provided:

1. Seller is notified promptly upon discovery by purchaser that stated products are defective.
2. Such products are properly packaged and then returned freight prepaid, to seller's plant.

This warranty does not apply to any parts damaged during shipment and/or due to improper handling, or due to improper installation or usage, or alteration. In no event shall the seller be liable for any anticipated profits, loss of profits, loss of use, accidental or consequential damages, or any other losses incurred by the customer in connection with the purchase of a Stern Pinball Inc Product.

### WARRANTY DISCLAIMER

Except as specifically provided in a written contract between seller and purchaser, there are no other warranties, express or implied, including any implied warranties of merchantability or fitness for a particular purpose.

This Game Service Manual and all other documents relating to this product, playfield components, features, rules, programming, and operation are subject to change without notice (Service Bulletins, if applicable, available through official Stern Pinball website).

## 6.3 WARNINGS, COMPLIANCE, AND LEGAL NOTICES

### PHOTOSENSITIVE SEIZURES HEALTH WARNING



A very small percentage of people may experience a seizure when exposed to certain visual images, including flashing lights or patterns. Even people with no history of seizures of epilepsy may have an undiagnosed condition that can cause "photosensitive epileptic seizures" due to certain visual images, flashing lights or patterns. Symptoms can include light-headedness, altered vision, eye or face twitching, jerking or shaking of arms or legs, disorientation, confusion, momentary loss of awareness, and loss of consciousness or convulsions that can lead to injury from falling down or striking nearby objects.

IMMEDIATELY STOP PLAYING AND CONSULT A DOCTOR IF YOU EXPERIENCE ANY OF THESE SYMPTOMS.

### PARTS SUBSTITUTIONS



For safety and reliability, substitute parts and equipment modifications are not recommended and may void any and all warranties. Use of Non-Stern Pinball Inc Parts or Modifications of game circuitry may adversely affect game play or game safety. Transport pinball machines with hinged backbox in the down position only! Always take great care when servicing any game. Always read the service manual before replacing or servicing components. Substitutions of parts or equipment modifications may void FCC type acceptance.

Always disconnect the line voltage before servicing. Some parts may remain energized when unplugged. Take great caution when servicing any electrical components.

### FCC CLASS A SUBPART J COMPLIANCE



This equipment has been tested and found to comply with the limits for a Class A digital device, pursuant to part 15 of the FCC Rules. These limits are designed to provide reasonable protection against harmful interference when the equipment is operated in a commercial environment. This equipment generates, uses, and can radiate radio frequency energy and, if not installed and used in accordance with the instruction manual, may cause harmful interference to radio communications. Operation of this equipment in a residential area is likely to cause harmful interference in which case the user will be required to correct the interference at his own expense.

### RF INTERFERENCE NOTICE

The cable harness placements, ground strap routing, and other shielding have been designed to keep RF radiation and conduction within levels accepted by FCC rules. To maintain these levels, factory harness position, shielding, and ground straps must be installed in their factory locations should they become disconnected during maintenance.

### COPYRIGHT AND INTELLECTUAL PROPERTY NOTICE

This document and the data disclosed herein or herewith is not to be reproduced (Except where noted), used, or otherwise disclosed in whole or in part to anyone without written consent of Stern Pinball Inc.

Products in this manual, the company name and devices and the design of the manual itself are protected by federal patents (and patents pending), design registrations, trademarks, and copyrights. Action will be taken in the event of infringement or imitation. The right is reserved to change specifications without prior notice.





# STAR WARS

TM

**1-800-KICKERS**  
PARTS.SERVICE@STERNPINBALL.COM  
WWW.STERNPINBALL.COM  
FACEBOOK.COM/STERNPINBALL

STAR WARS LE #500-55J6-01  
STAR WARS PREMIUM #500-55J7-01  
MANUAL #780-50J6-00

