

# AMERICAN HERITAGE-14' QUEST SHUFFLEBOARD

## Assembly Instruction

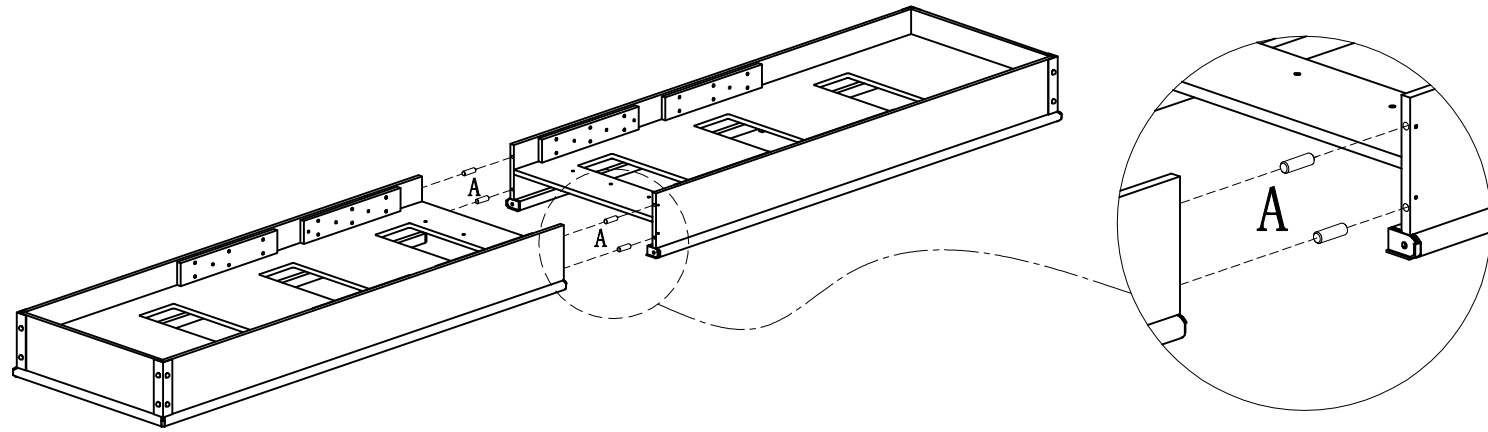



1/4

Step 1. Lay both cabinet pieces upside down on a cleat flat surface and connect them by using the Dowels(A)

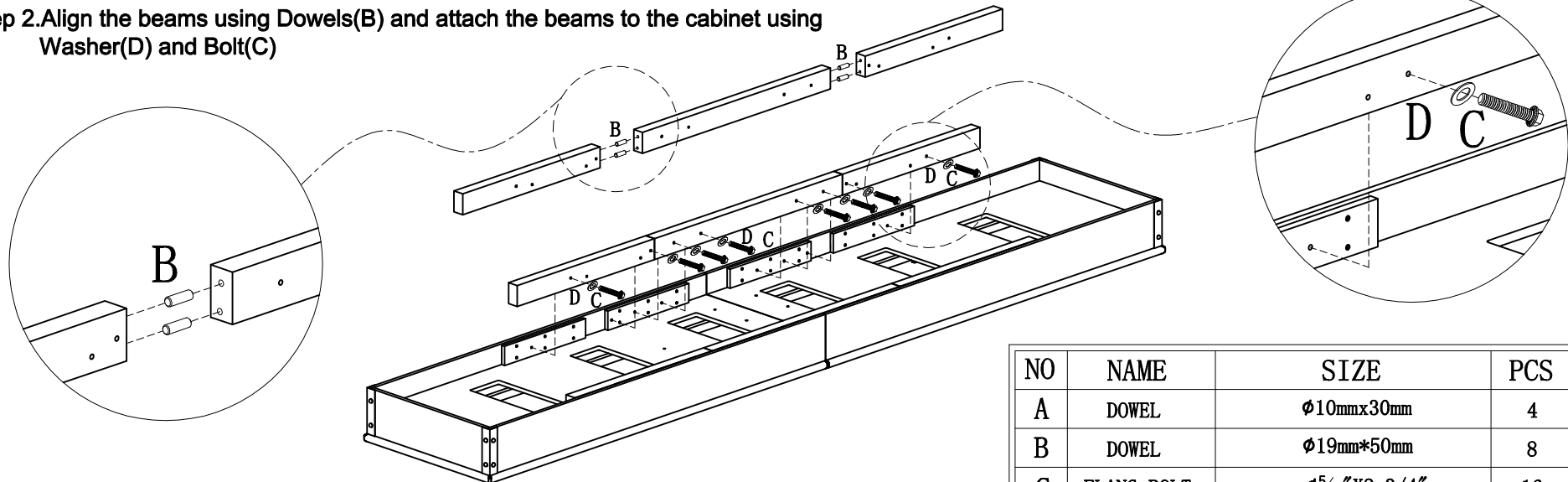

Step 2. Align the beams using Dowels(B) and attach the beams to the cabinet using Washer(D) and Bolt(C)



NO	NAME	SIZE	PCS	DRAW
A	DOWEL	φ10mmx30mm	4	
B	DOWEL	φ19mm*50mm	8	
C	FLANG BOLT	φ <sup>5</sup> / <sub>16</sub> " X2-3/4"	16	
D	WASHER	φ <sup>5</sup> / <sub>16</sub> " X3/4" X2mm	16	

# AMERICAN HERITAGE-14' QUEST SHUFFLEBOARD

## Assembly Instruction



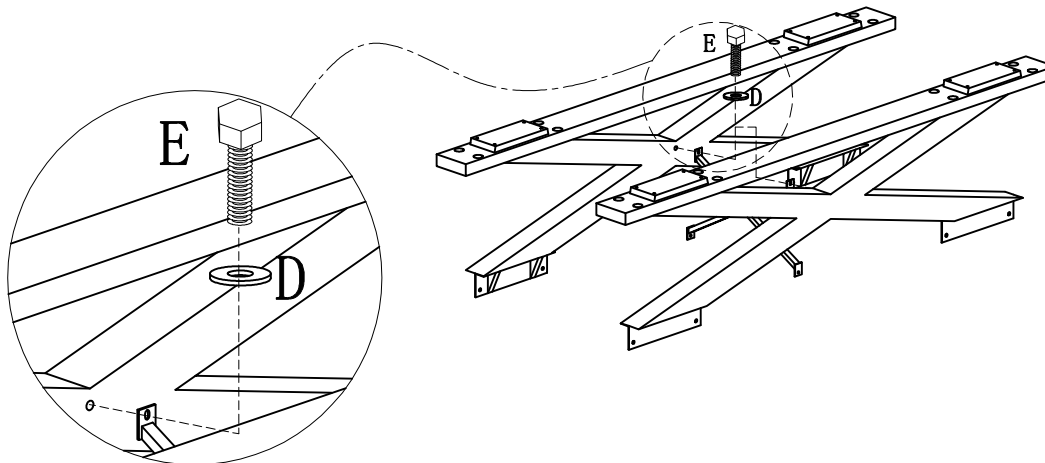

2/4

Step 3. Pre-assemble the legs using Washer(D) and Bolt(E)

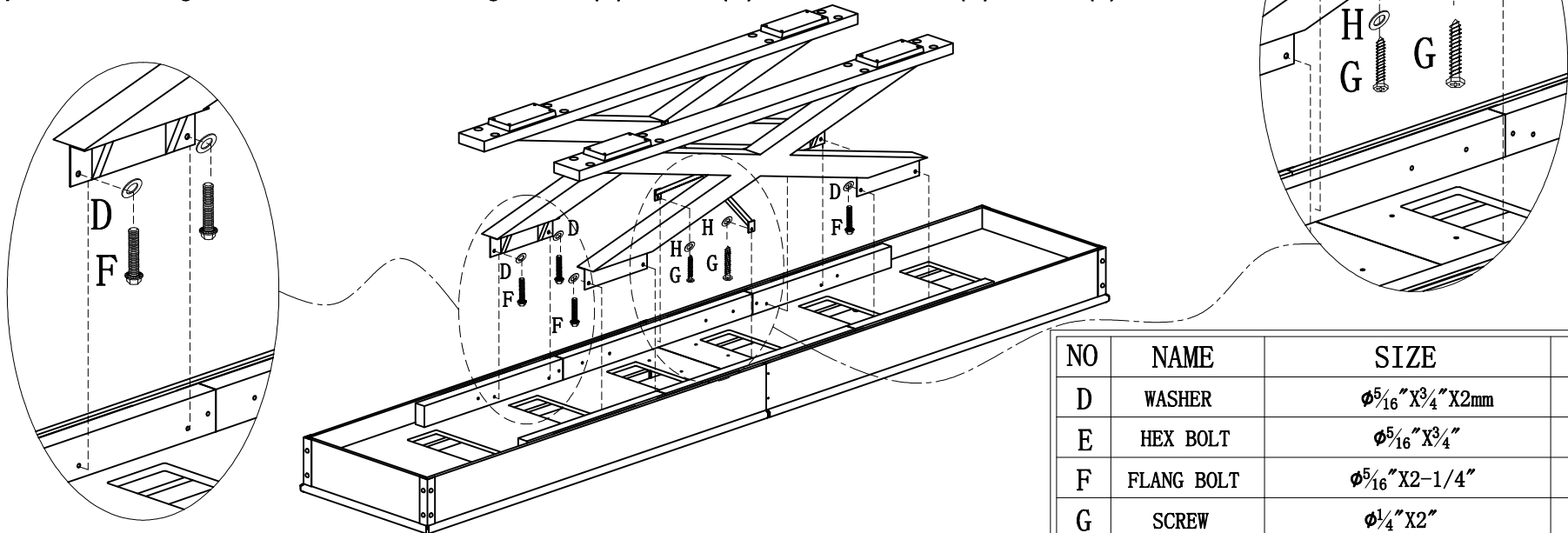

Step 4. Attach the legs to the cabinet beams using Washer(H) and Bolt(G) as well as Washer(D) and Bolt(F)



NO	NAME	SIZE	PCS	DRAW
D	WASHER	$\phi^{5/16}$ "X $3/4$ "X2mm	10	
E	HEX BOLT	$\phi^{5/16}$ "X $3/4$ "	2	
F	FLANG BOLT	$\phi^{5/16}$ "X2- $1/4$ "	8	
G	SCREW	$\phi^{1/4}$ "X2"	2	
H	WASHER	$\phi^{1/4}$ "X $5/8$ "X2mm	2	

# AMERICAN HERITAGE-14' QUEST SHUFFLEBOARD

## Assembly Instruction



3/4

Step 5. Using 2 or more strong adults, carefully turn the cabinet right side up

Step 6. Using 2 or more strong adults, carefully place the playfield in the cabinet and center it by measuring the distance from the playfield to the cabinet on all four sides

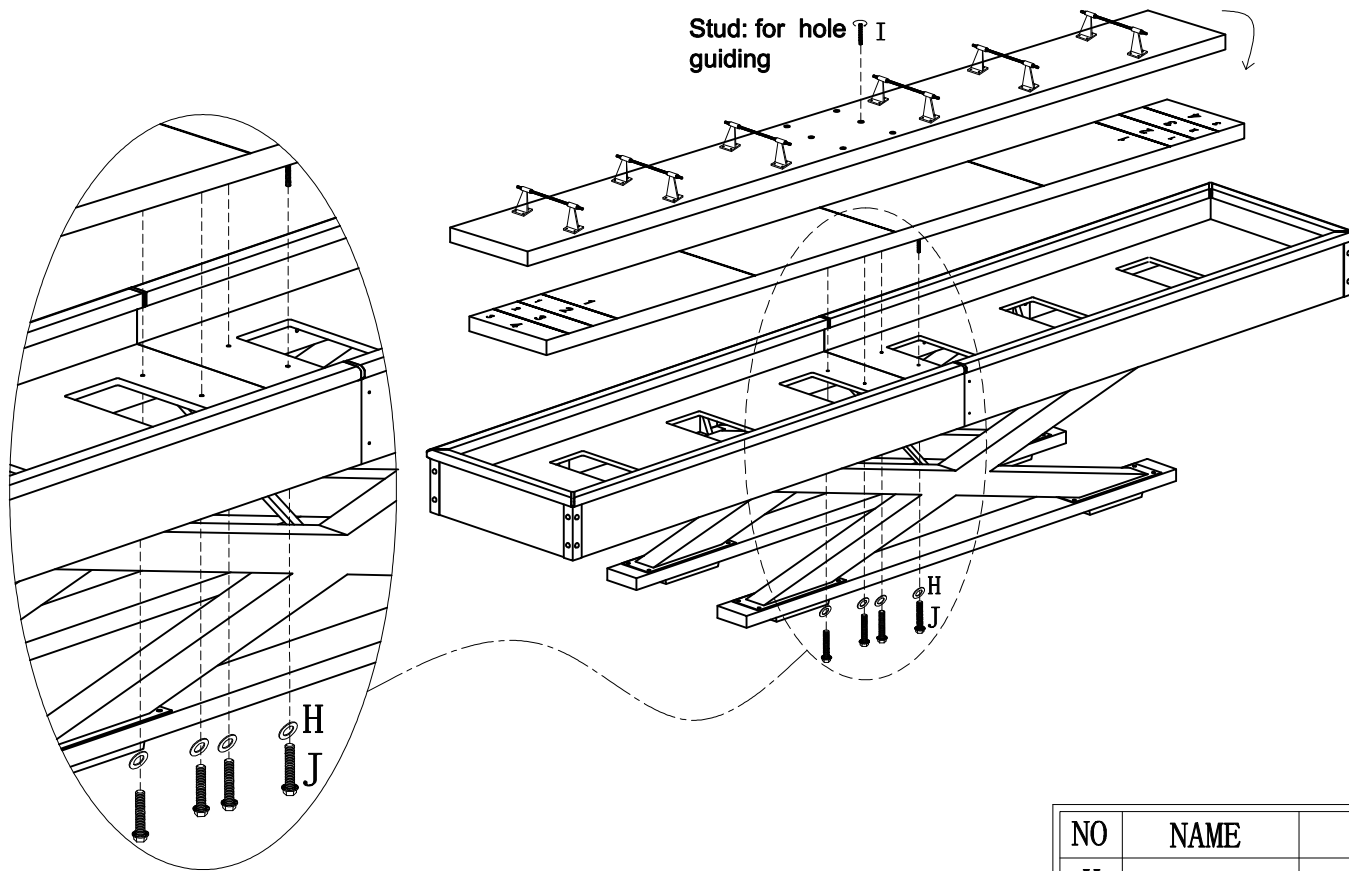
Step 7. Secure the playfield to the cabinet using Washer(H) and Bolt(J)



NO	NAME	SIZE	PCS	DRAW
H	WASHER	$\phi\frac{1}{4}$ " X $\frac{5}{8}$ " X 2mm	6	
I	STUD	$\phi\frac{1}{4}$ " X 3"	1	
J	FLANG BOLT	$\phi\frac{1}{4}$ " X 1 $\frac{3}{4}$ "	6	

# AMERICAN HERITAGE-14' QUEST SHUFFLEBOARD





## Assembly Instruction

4/4

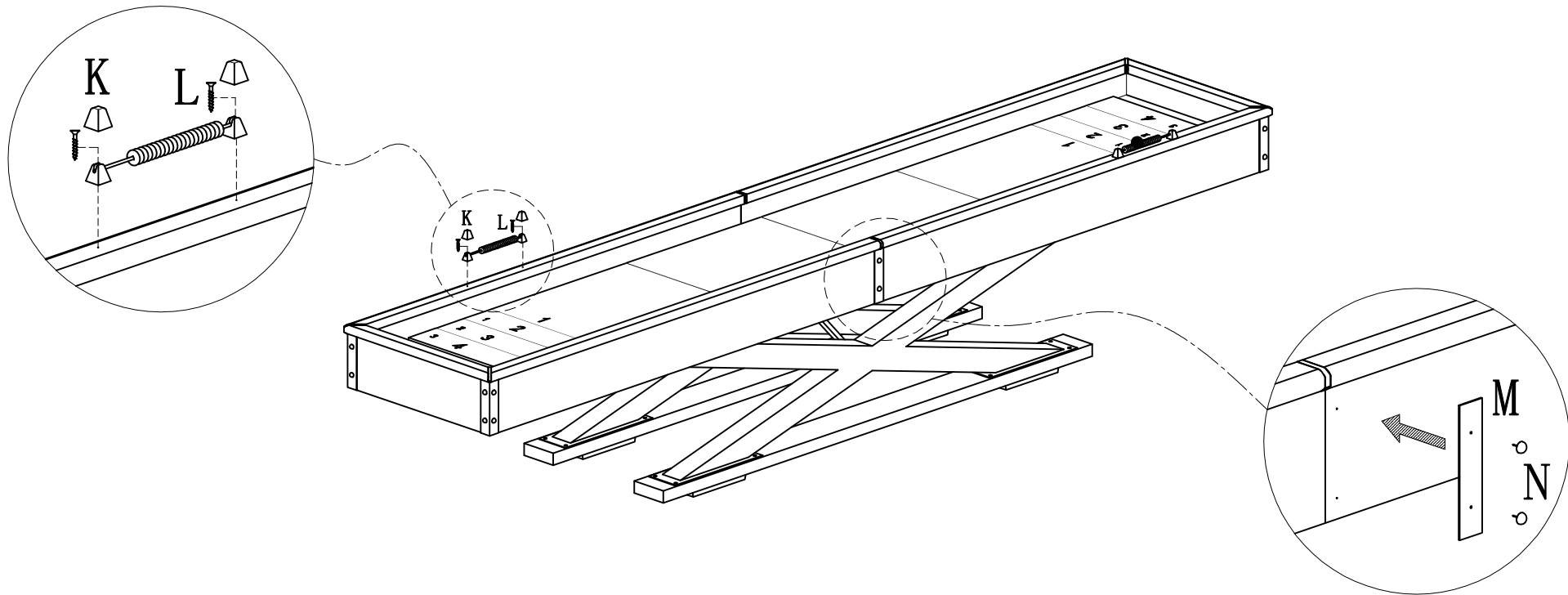
Step 8. Attach the Metal Plates(M) to the cabinet sides by using a rubber mallet to insert Tack(N) in to the cabinet using the pre-drilled pilot holes

Step 9. Attach the manual scoring units to the cabinet using Screw(L)



NO	NAME	SIZE	PCS	DRAW
K	SCORE UNIT		2	
L	SCREW	#6X1"	4	
M	METAL PLATE	9"X2"X1/8"	2	
N	BRASS NAIL		4	