

ASSEMBLY INSTRUCTION MANUAL

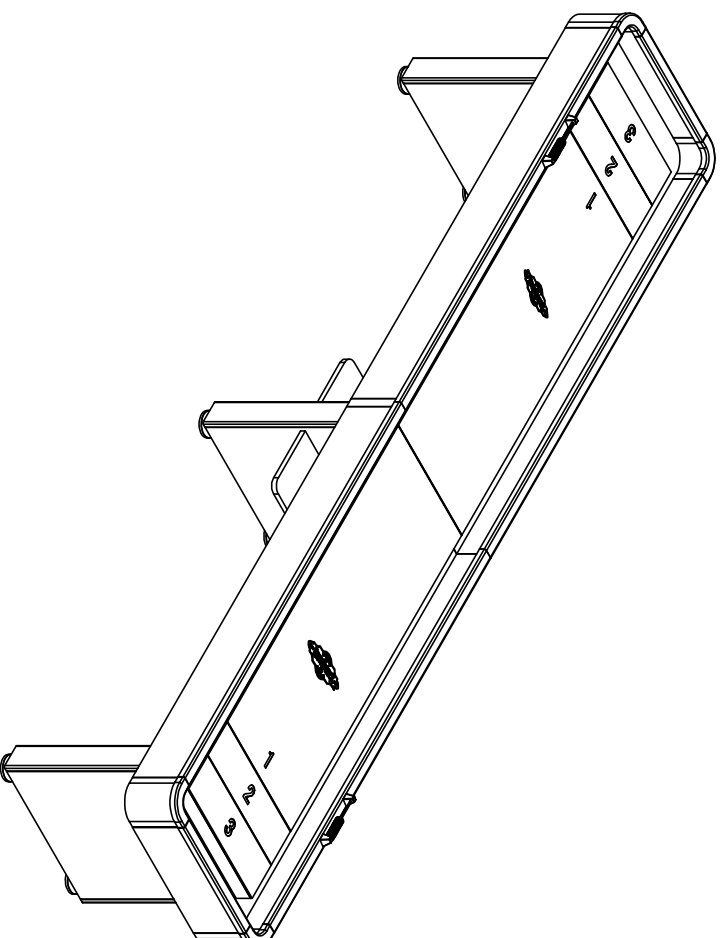

12' & 14' DELRAY II SHUFFLEBOARD



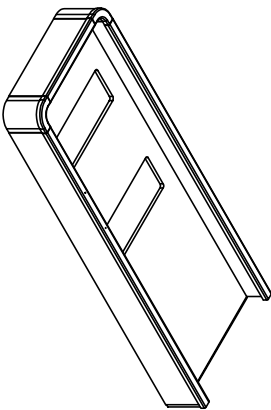
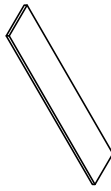
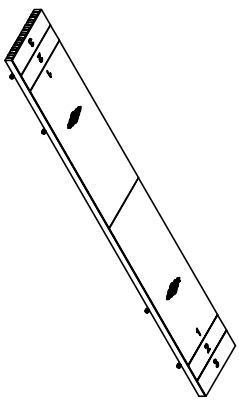
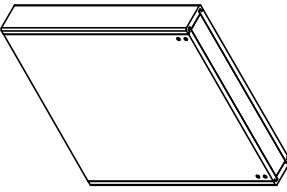
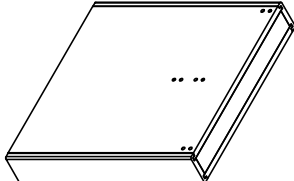
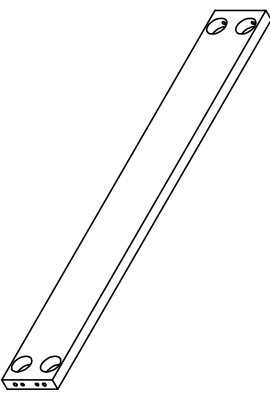
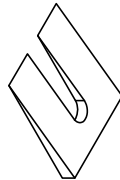
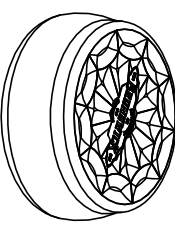
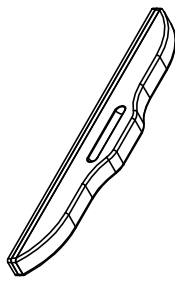
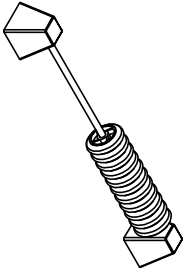
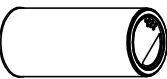
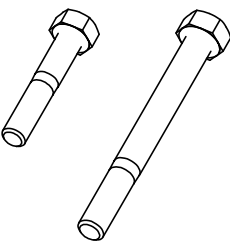

www.brunswickbilliards.com
SERVICE DEPARTMENT, P.O. BOX 68, BRISTOL, WI 53104
EMAIL: BRUNSWICKSERVICE@BRUNSWICKBILLIARDS.COM

PACKAGE CONTENTS - 12' & 14' DELRAY II SHUFFLEBOARD

 <p>CABINET HALF(2)</p>	 <p>CABINET CENTER TRIM(2)</p>	 <p>PLAY FIELD(1)</p>	 <p>END PEDESTAL(2)</p>
 <p>CENTER PEDESTAL(1)</p>	 <p>STRETCHER ASSY (2)</p>	 <p>WOOD LEG WEDGE(6)</p>	 <p>WEIGHTS-RED(4)/BLACK(4)</p>
 <p>BOARD SWEEP(1)</p>	 <p>SCORING ABACUS RED(1)BLACK(1)</p>	 <p>SHUFFLEBOARD WAX(1)</p>	 <p>BOLT, 5/16-18UNC X 3(24) BOLT, 5/16-18UNC X 1 3/4(4)</p>

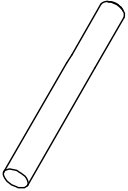
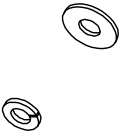
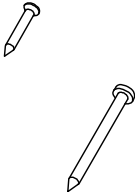
PACKAGE CONTENTS CONTINUED 12' & 14' DELRAY II SHUFFLEBOARD

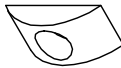
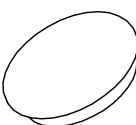
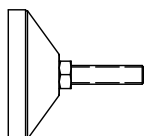
 <p>THREADED ROD, 5/16-18UNC X 3-1/2"(8)</p>	 <p>FLAT WASHER, 5/16(28) SPRING LOCK WASHER, 5/16(24)</p>	 <p>PAN HEAD SCREW, #8 X 2(6) FLAT HEAD SCREW, #8 X 1(4)</p>	 <p>WOOD DOWEL, 10mm X 30mm(12)</p>
 <p>HEX NUT 5/16(8)</p>	 <p>GRADLE NUT 5/16 (8)</p>	 <p>HOLE CAP (8)</p>	 <p>FOOT LEVELER ASSY (8)</p>

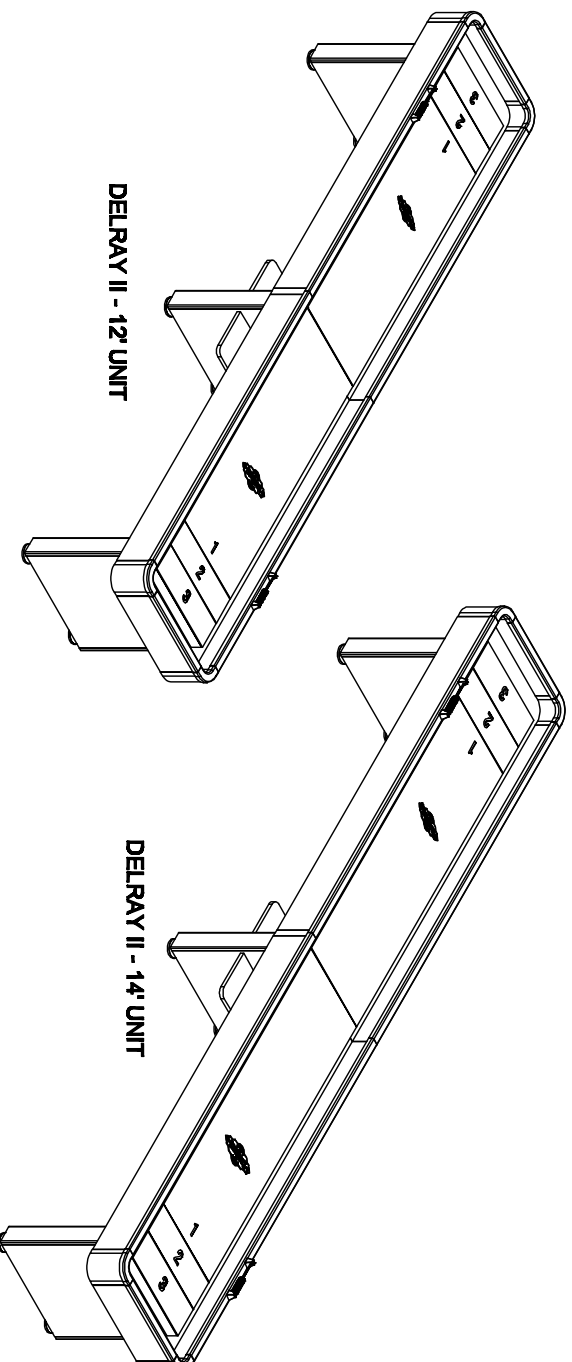

12' & 14' DELRAY II SHUFFLEBOARD

FOOT LEVELER AND STRETCHER ASSEMBLY:

- Step 1: Turn over the leg, then attach Foot Leveler into holes on leg .
- Step 2: Turn Leg over again, Place Stretcher between Center Pedestal and Side Pedestal to connect it.
- Step 3: Insert Dowel into dowel holes on stretcher, Pair (8) Threaded Rod 5/16x3-1/2, (8) Cradle Nut 5/16", and (8) Hex Nut 5/16
- Step 4: Connect stretcher to Leg. (see Figure 1)
- Step 5: Close Holes on side of stretcher using Hole Cap, (see figure 2)

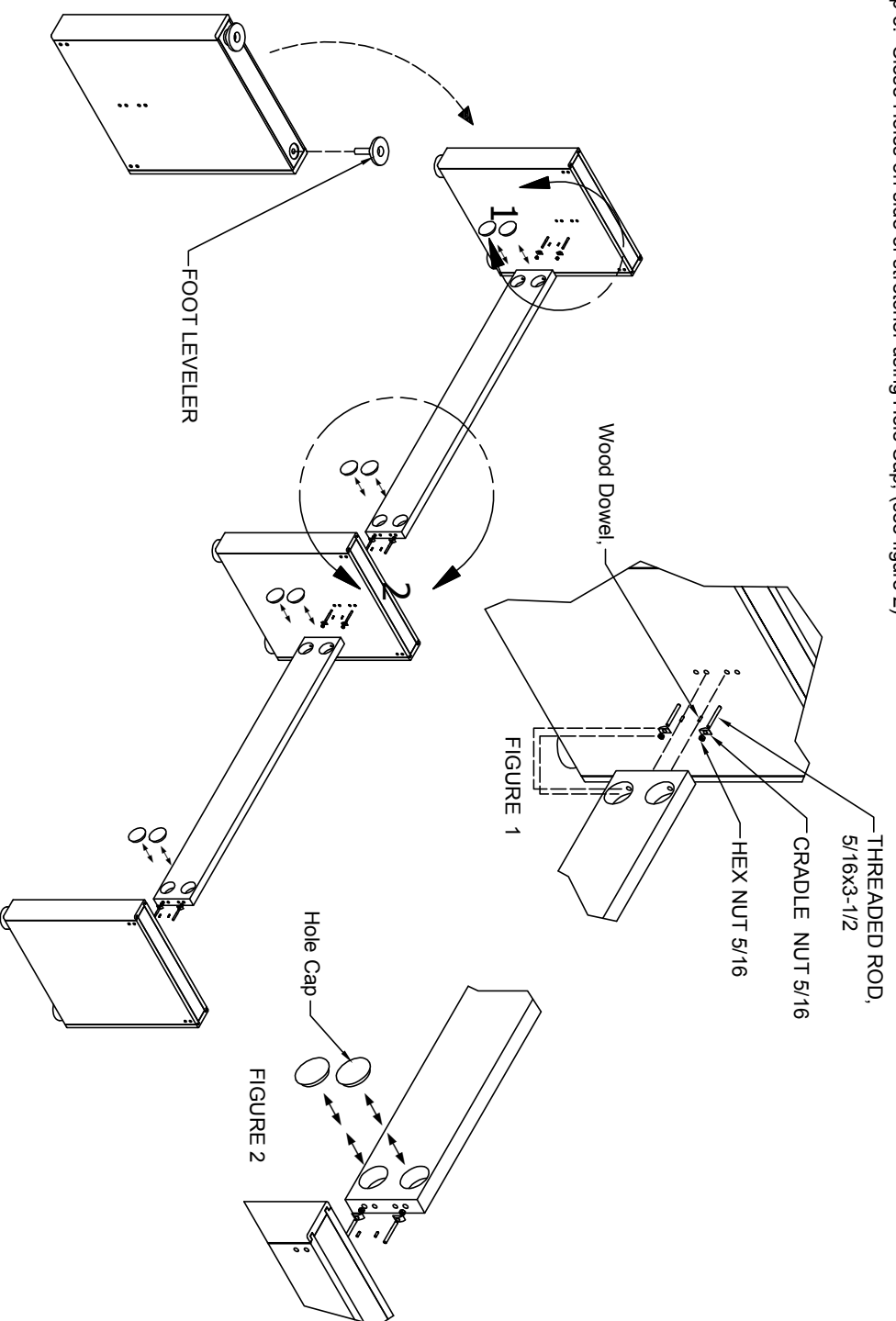

12' & 14' DELRAY II SHUFFLEBOARD

CABINET & SHELF ASSEMBLY:

- Step 1:** Place each cabinet half upside down inline near the final unit location.
(Use protective material, such as slipping blankets, between cabinet and floor)
- Step 2:** Insert wood dowels into dowel holes on one cabinet half and slide the cabinet halves together. (See Figure 3)
- Step 3:** Slide two end pedestals and one center pedestal into place as shown.
- Step 4:** Add Wedge between Pedestal and Cabinet Frame as needed, then attach each pedestal using (8) 5/16" flat washers, (8) 5/16 spring lock washer, and (8) 5/16-18UNC X 3 hex bolts. (See Figure 4)
- Step 5:** Attach a shelf side to each shelf panel using (4) 5/16 flat washer and (4) 5/16-18UNC hex bolts. (See Figure 5)

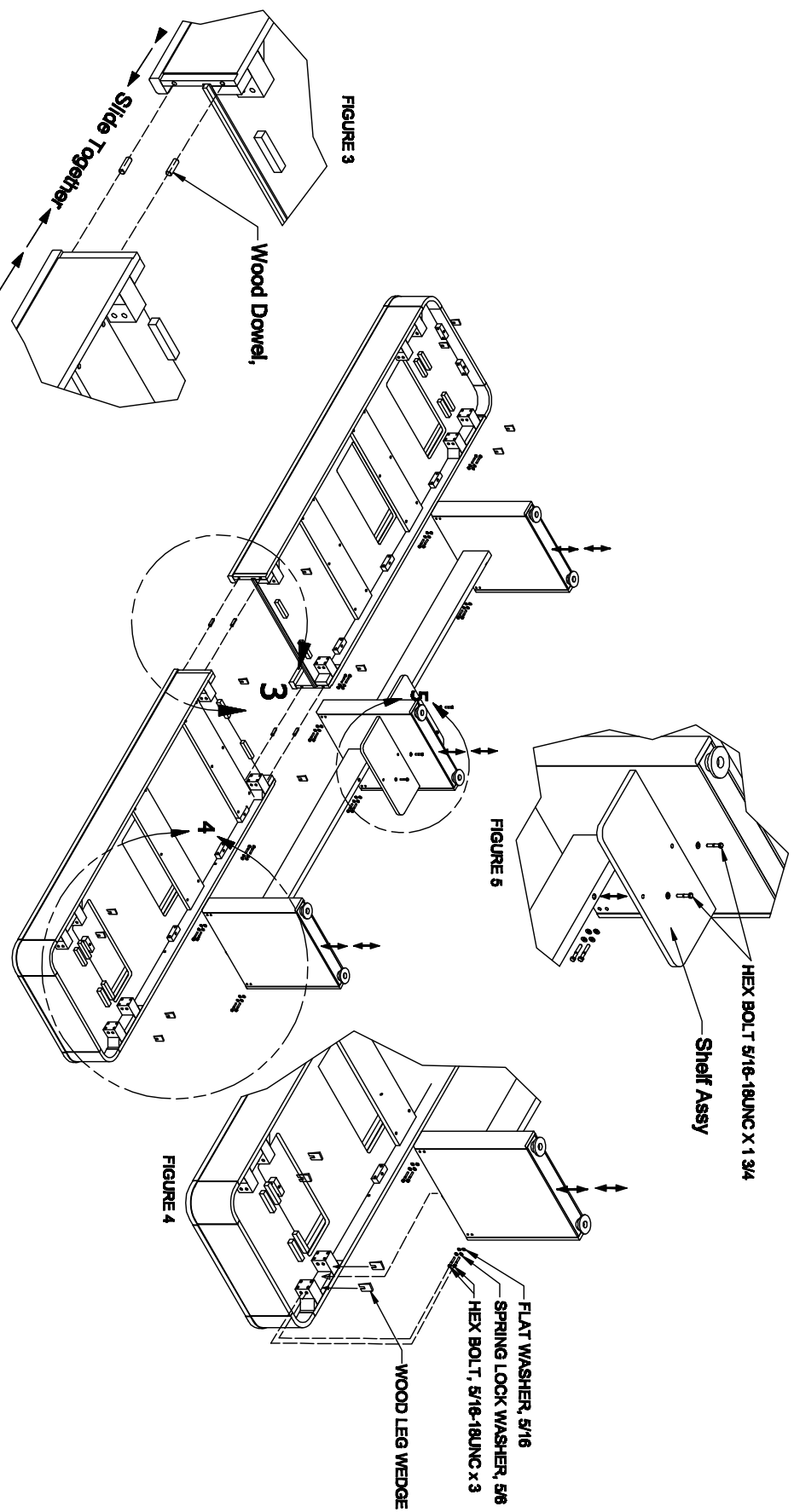

12' & 14' DELRAY II SHUFFLEBOARD

CABINET PLACEMENT & LEVELING:

Step 1: Flip assembled cabinet over into an upright position and place in the final unit location.

Step 2: Using a bubble level, adjust pedestal levelers until the cabinet is level across width and along the entire length. (See Figure 6)

PLAY FIELD PLACEMENT & ADJUSTMENT:

Step 1: Place play field into the cabinet. For best results use weights, two on each end, to rest the play field on and prevent injury. Lift each end from under the cabinet, one end at a time, and remove the weights. Center the play field within the cabinet equally in both directions.

Step 2: Using the climate adjusters attached to the bottom of the play field, create a concave condition across the width of the play field along the entire length. This is recommended for proper play. (See Figure 7)(Check with a straight edge across width at each climate adjuster. A sheet of paper should go under at the center of the straight edge when properly adjusted)

Step 3: After adjusting play field, check that the play field is level in both directions and along the entire length. Adjust pedestal levelers to raise or lower the cabinet as needed.

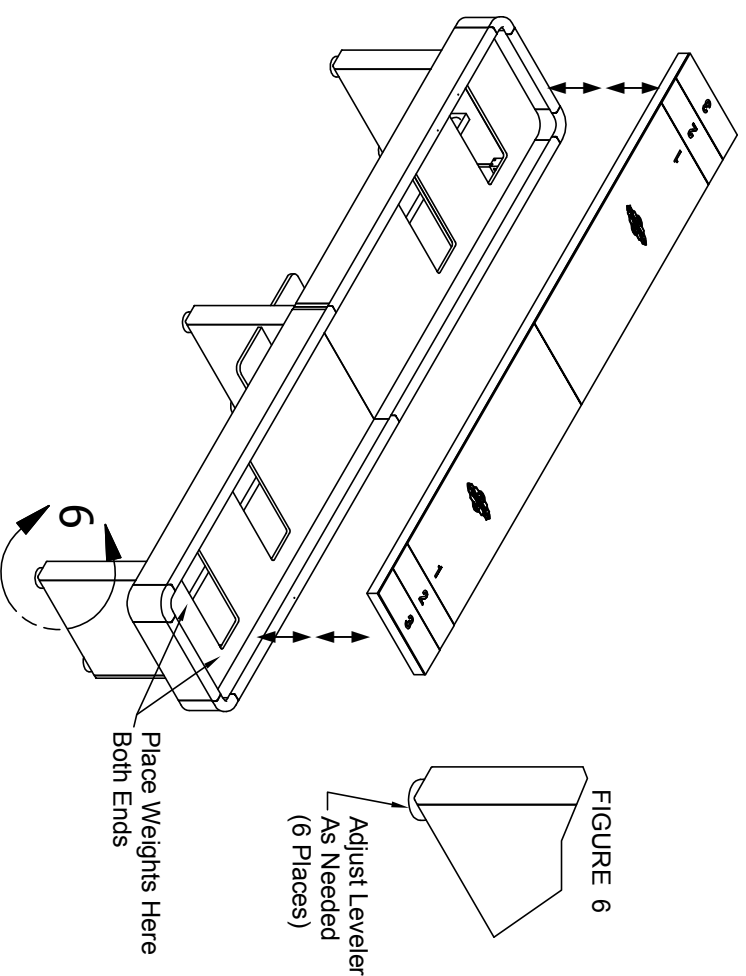
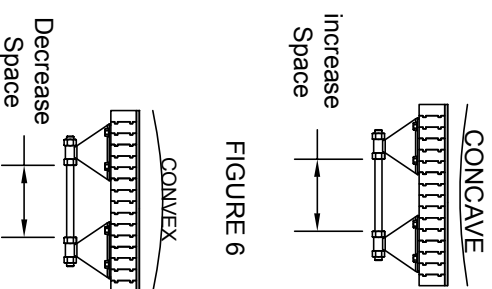

12' & 14' DELRAY II SHUFFLEBOARD

ATTACHMENT - MANUAL SCORING ABACUS:

- Step 1: For each manual scoring abacus, attach two molded anchors using (4)#6 x 1 flat head screws. Be sure the slots in the top of each anchor run parallel with the side of the cabinet. (**See Figure 9**)
- Step 2: Align the remainder of the abacus assembly over the two anchors making sure the scoring beads are oriented correctly with the two black or red beads away from the end of the cabinet. Apply downward pressure on each end cap snapping the slide rod into each anchor securing the assembly in place. (**See Figure 9**)

PLAY SURFACE PREPERATION:

- Step 1: Wipe the entire surface clean with a soft clean cotton cloth and apply a light coat of fine mist silicone spray(**NOT INCLUDED**). Allow the silicone to settle for 10 minutes.
- Step 2: Apply an even covering of shuffleboard wax to the play surface and allow to rest for another ten minutes. Apply additional wax in areas that appear dry as needed.
- Step 3: Let the game begin. **ENJOY!** See page 8 for Rules of Play.

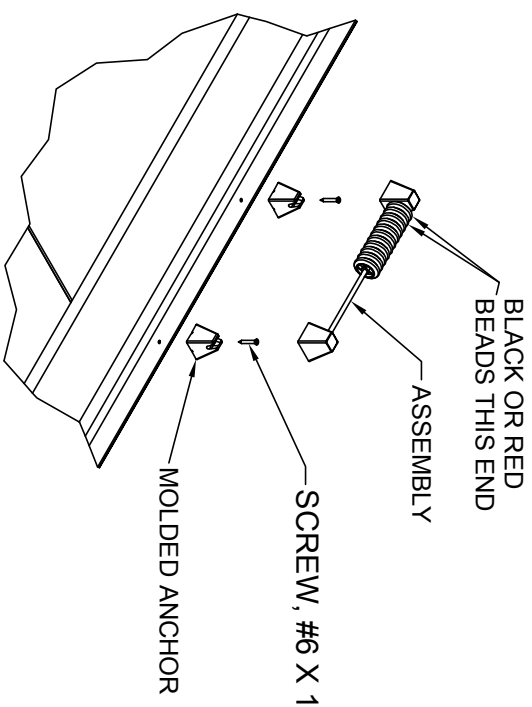
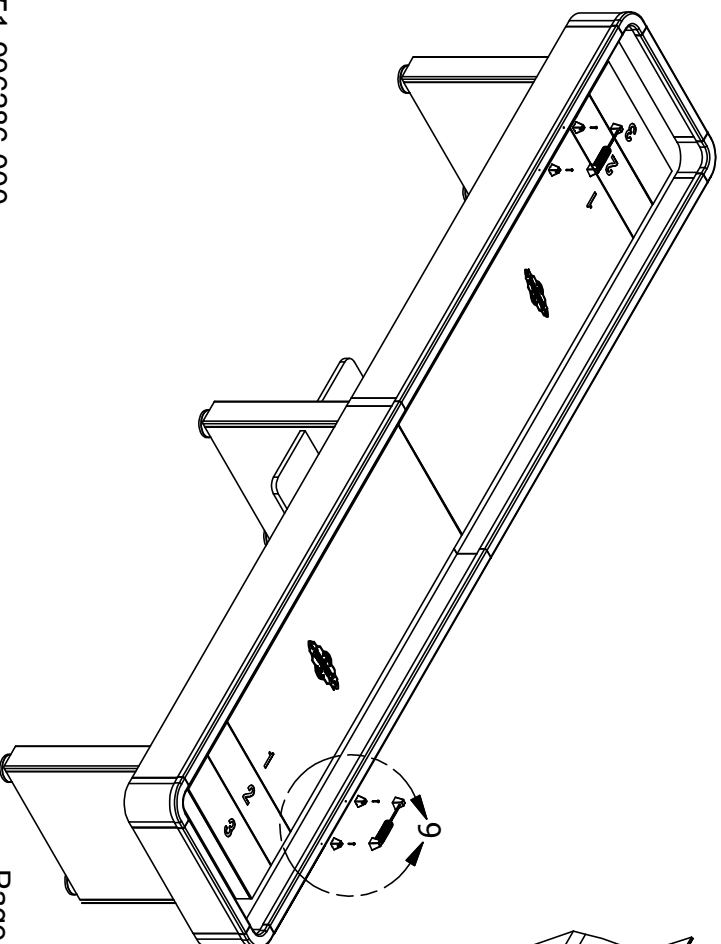

FIGURE 9

12' & 14' DELRAY II SHUFFLEBOARD

BASIC RULES OF PLAY:

1. Object of the game is to score more points than your opponent by either knocking their weights off the play surface or by sliding your weights into a higher scoring zone. A typical game, singles or partners, is played to 15 points.
2. A coin toss determines who will shoot first, and thus, who gets the hammer. The hammer is the person or team that shoots last. It is considered advantageous to have the hammer. The winner of the coin toss normally takes the hammer and the loser gets to pick the color of weights they will use during play.
3. Player A (loser of coin toss) begins by shooting one weight. Player B then shoots one weight, and play alternates as such, until Player B shoots the last weight (hammer).
4. After all weights have been played, the players determine who scored by counting only the weights of a single color that are closest to the end of the play surface. A weight must be completely inside a score zone to receive the points in that zone.
5. The player or team that scores in each frame must shoot first in the next frame. This process is repeated until a player or team reaches 15 points for the win.

MAINTENANCE/CLEANING:

1. Remove household dust with a soft, dampened cloth. Dust in the direction of the wood grain to prevent noticeable scratches from dust particles. For more thorough cleaning, a solution of mild soap or oil soap for wood is recommended. Spray furniture waxes and polishes are not necessary and can cloud the furniture finish.
2. Wood furniture should not be exposed to extreme heat or humidity. Avoid placing your furniture near vents, radiators, fireplaces or air conditioning units. To protect your finish against fading, avoid exposure to direct sunlight.
3. Using the provided board sweep, push away the shuffleboard wax into the gutter with a sweeping motion down the length of the play surface. The wax can then be removed using a vacuum. Apply a fresh coat of silicone and shuffleboard waxper steps on page 7. This should be done monthly under regular usage and more often under heavy play.
4. Throughout the year your shuffleboard may react to temperature and/or humidity changes. When cleaning the play field, check to insure the play field is still in a concave condition. If the play field needs adjustment, follow the steps in the instructions on page 6.
5. When moving your assembled shuffleboard to a new location, dismantle and reassemble in that new location. Moving completely assembled shuffleboard units can crack and/or split wood components or cause personal injury.