

# SERVICE MANUAL

## ★ DC ★ SUPER HEROES



Ver 1.0



ISSUE DATE: May. 2, 2018



- ▶ Please read the manual carefully and keep it in mind before using this machine.
- ▶ Put this manual within touch of your reference in anytime.

# PRECAUTIONS FOR USE

The following safety precautions are given throughout this manual. They must be strictly followed to protect those who install, use or maintain this product as well as to protect players, visitors and property.

## For safety reasons.

- The following suggestions should be adhered to:



Disregarding could result in serious injury.



Disregarding could result in injury or product damage.

- The following graphic suggestions describe the types of precautions to be followed.



Indicates a care should be taken.



Forbidden.



Indicates a matter which must be performed.

- **Precautions to be followed:**

**Certain procedures require a qualified in-shop maintenance person or industry specialist. For such instructions, a qualified person must take care of the jobs.**

- Otherwise an electric shock, machine trouble, or a serious accident may result.
- Replacing the machine parts, inspecting and maintaining the machines, and troubleshooting must be assigned only to a qualified in-shop maintenance person or industry specialist. This booklet gives instructions that hazardous jobs in particular must be handled by an industry specialist. Qualified in-shop maintenance person and industry specialist are defined as follows.

### **Qualified in-shop maintenance person**

- A service staff shall have experience in operations of game machines. The staff shall be responsible for assembly, installation, inspection and maintenance of the machine.

### **Industry specialist**

- An industry specialist must be engaged in designing, manufacturing, inspecting and servicing amusement machines. He or she must have an education in electrical, electronic and mechanical engineering, and routinely maintain and repair amusement machines.

# PRECAUTIONS FOR USE

## WARNING

**Be sure to consult an industry specialist when setting up, moving or transporting this product.**

- This product should not be set up, moved or transported by any one other than an industry specialist.
- When installing this product, set the 4 leg levelers evenly on the floor and make sure that the product is installed stably in a horizontal position. Unstable installation may result in injury or accident.
- When installing this product, do not apply undue force on movable parts. Otherwise, injury and accident may result, or the product may be damaged.

**The machine for indoor usage only does not install outside.**



**Do not set the game machine up near emergency exits.**



**Protect the game machine from:**

- Rain or moisture.
- Direct sunlight.
- Direct heat from air-conditioning and heating equipment, etc..
- Hazardous flammable substances.
- Otherwise an accident or malfunction may result.



**Do not place containers holding chemicals or water on or near the game machine.**



**Do not place objects near the ventilating holes.**



**Do not bend the power cord by force or place heavy objects on it.**



**Never plug or unplug the power cord with wet hands.**



**Never unplug the game machine by pulling the power cord.**



## CAUTION

**Be sure to use indoor wiring within the specified voltage requirements. For extension cord, use the specified rating or more.**

**Be sure to use the attached power cord.**

**Never plug more than one cord at a time into the electrical receptacle.**



**Do not lay the power cord where people walk through.**



**Be sure to ground this product.**



**Do not exert excessive force when moving the machine.**



**For proper ventilation, keep the game machine 100mm(4") away from the walls.**

**Do not alter the system related dipswitch settings.**

# PRECAUTIONS FOR USE

## WARNING

**If there is any abnormality such as smoke, bad smell or abnormal noise being emitted from the machine, immediately turn OFF the main power switch and unplug the power cord from the receptacle to stop operating it.** 

- Using the machine in abnormal conditions could result in fire or accidents.

### In case of abnormality

1. Turn OFF the main power switch.
2. Unplug the power cord from the receptacle.
3. Contact your nearest dealer.

**Do not leave the power cord plugged in improperly or covered with dust.** 

- Doing so could result the power cord periodically.

## CAUTION

**Do not use this product anywhere other than industrial areas.** 

- Using in a residential area or an area next to a residential area could affect signal reception of radios, television sets, telephones, etc..
- Do not give shock the surface of glass products.

- Please do not play this game if
  - When you do drinking;
  - When your physical condition is not normal;
  - When you are in pregnancy;
  - When you have on a pulse controller;
  - When you have recently experienced a cramp or fainting away while watching TV.
- Avoid excessive force/shock while playing/moving the game.
- While do games, pay attention to surrounding.

**Do not plug or unplug the power cord with wet hands.** 

**In handling the power cord, follow the instructions below.** 

- |   |  |
|---|--|
| • Do not damage the power cord.           | • Do not modify the power cord.            |
| • Do not bend the power cord excessively. | • Do not twist the power cord.             |
| • Do not heat the power cord.             | • Do not pull the power cord.              |
| • Do not bind the power cord.             | • Do not stand on the power cord.          |
| • Do not sandwich the power cord.         | • Do not drive a nail into the power cord. |

**If the power cord or power plug becomes damaged, stop using the machine immediately and ask your nearest dealer to replace the parts.**

**\* Electromagnetic wave may cause unexpected noise from speaker.**

# PRECAUTIONS FOR USE

## ⚠ WARNING

Be sure to turn OFF the main power switch and unplug the power cord from the receptacle before inspecting or cleaning the machine.



When replacing parts, be sure to use parts of the correct specifications. Never use parts other than the specified ones.



Opening inside the machine shall be done by machine specialist only as high electric current is being sent inside. For game machine with monitor, a care should be taken while opening its back door. If not, a damage to the inside parts or the monitor may occur.



If the sub power switch of the service panel is turned OFF without turning OFF the main power switch of the power supply unit, some parts in the units remain live. When opening the back door, be sure to turn OFF the main power switch and unplug the power cord from the receptacle.



Strictly refrain from disassembly and repair of parts which are not indicated in this manual, as well as settings and remodeling.



To clean the game machine, wipe it with a soft cloth dampened in a neutral detergent.

- Using thinner or other organic solvent or alcohol may decompose the material.
- Electrical shock or equipment failure could be caused by water entering the inside of the machine.

## ⚠ CAUTION

Components in the game are sensitive to vibrations and impact. Care should be used when moving and transporting the game machine.



Be sure not to let the machine tip over.

Before moving the machine, be sure to turn OFF the main power switch, unplug the power cord from the receptacle and remove the power cord from the machine.



Before moving take the machine, off the levelers and move it on the casters.

Avoid excessive force while moving the machine.

.....

## PRECAUTIONS IN HANDLING

- When setting up, inspecting, maintaining, moving or transporting this product, follow the procedures and instructions set forth in this manual and perform such work safely.
- Do not set up, handle, inspect, maintain, move or transport this product under conditions equivalent to the condition of "WARNING" or "CAUTION" specified in this manual.
- If a new owner is to have this product as a result of transfer, etc., be sure to give this manual to the new owner.

# PRÉCAUTION D'EMPLOI

Les consignes de sécurité suivantes sont données dans ce manuel. Elles doivent être strictement suivies pour protéger ceux qui les installent. Utiliser ou entretenir ce produit pour la sécurité des utilisateurs, des visiteurs et des biens.

Pour des raisons de sécurité.

- **Les suggestions suivantes doivent être respectées:**

## **ATTENTION**

Le non-respect peut entraîner des blessures graves.

## **PRUDENCE**

Le non-respect peut entraîner des blessures ou des dommages au produit.

- **Les suggestions graphiques suivantes décrivent les types de précautions à prendre.**



Indique qu'attention est requise.



Interdit.



Indique que quelque chose doit être effectuée.

- **Les précautions à prendre :**

**Certaines procédures exigent une personne de maintenance qualifiée en atelier ou un spécialiste de l'industrie. Pour ces instructions, une personne qualifiée doit prendre soin des travaux.**

- Sinon, un choc électrique, un dysfonctionnement de la machine, ou un accident grave peut en résulter.
- Remplacement des pièces de machines, l'inspection et la maintenance des machines, et le dépannage doit être attribué qu'à une personne de maintenance qualifiée en atelier ou spécialiste de l'industrie. Cette brochure donne des instructions que les emplois dangereux, en particulier, doivent être traités par un spécialiste de l'industrie. La personne de maintenance qualifiée en atelier et le spécialiste de l'industrie sont définis comme suit.

### **La personne de maintenance qualifiée en atelier**

- Un personnel de service doit avoir de l'expérience dans les opérations de machines de jeux. Le personnel est responsable pour l'assemblage, l'installation, l'inspection et l'entretien de la machine.

### **Le spécialiste de l'industrie**

- Un spécialiste de l'industrie doit être engagé dans la conception, la fabrication, l'inspection et l'entretien des appareils d'amusement.  
Il ou elle doit avoir une formation en génie électrique, électronique et mécanique, et de maintenir régulièrement et de réparer les appareils d'amusement.

# PRÉCAUTION D'EMPLOI

## ATTENTION

Si il y a une anomalie comme fumée, mauvaise odeur ou bruit anormal émis par la machine,  couper immédiatement l'interrupteur principal et débranchez le câble d'alimentation de la prise pour arrêter son fonctionnement.

- L'utilisation de l'appareil dans des conditions anormales peut provoquer un incendie ou un accident.

En cas d'anomalie

1. Mettez l'interrupteur principal sur ARRÊT.
2. Débranchez le câble d'alimentation de la prise.
3. Contactez votre revendeur le plus proche.

**Ne pas brancher le câble d'alimentation incorrectement ou le laisser être recouvert de poussière.** 

Cela pourrait nuire le câble d'alimentation.

## PRUDENCE

**Ne pas utiliser ce produit ailleurs que dans les zones industrielles.** 

- L'utiliser dans une zone résidentielle ou d'une zone à côté d'un quartier résidentiel pourrait nuire à la réception des radios, téléviseurs, téléphones, etc.
- Ne donnez pas de choc à la surface d'un produit en verre.

- S'il vous plaît ne pas jouer à ce jeu.
  - Quand vous buvez;
  - Lorsque votre condition physique n'est pas normale;
  - Lorsque vous êtes dans une période de grossesse;
  - Lorsque vous avez un contrôleur d'impulsion;
  - Lorsque vous avez récemment subi une crampe ou évanouissement en regardant la télévision.
- Évitez une force excessive / un choc pendant la lecture / de déplacer le jeu.
- Quand vous jouez les jeux, faites attention aux alentours.

**Ne pas brancher ou débrancher le câble d'alimentation avec les mains mouillées.** 

**Dans la manipulation du câble d'alimentation, suivez les instructions ci-dessous.** 

- |  |   |
|--|---|
| • Ne pas endommager le câble d'alimentation.                 | • Ne pas modifier le câble d'alimentation.            |
| • Ne pas plier le câble d'alimentation de manière excessive. | • Ne tordez pas le câble d'alimentation.              |
| • Ne pas chauffer le câble d'alimentation.                   | • Ne tirez pas sur le câble d'alimentation.           |
| • Ne pas lier le câble d'alimentation.                       | • Ne montez pas sur le câble d'alimentation.          |
| • Ne pas prendre en sandwich le câble d'alimentation.        | • Ne pas mettre un clou dans le câble d'alimentation. |

**Si la fiche du câble d'alimentation ou est endommagé, cessez immédiatement d'utiliser la machine et demandez à votre revendeur le plus proche de remplacer les pièces.**

# PRÉCAUTION D'EMPLOI

## ATTENTION

**Assurez-vous de consulter un spécialiste de l'industrie lors de la mise en place, du déplacement ou le transport de ce produit.**

- Ce produit ne doit pas être mis en place, déplacé ou transporté par une quelconque autre qu'un spécialiste de l'industrie.
- Lors de l'installation de ce produit, installez 4 niveleurs de pieds uniformément sur le sol et assurez-vous que le produit est installé de façon stable dans une position horizontale. Une installation instable peut entraîner des blessures ou un accident.
- Lors de l'installation de ce produit, ne pas appliquer une force excessive sur les pièces mobiles. Sinon, des blessures et des accidents peuvent y résulter, ou le produit peut être endommagé.

**La machine pour une utilisation en intérieur uniquement, ne pas installer à l'extérieur.**



**N'installez pas la machine de jeu près des issues de secours.**



**Protéger la machine de jeu de:**



- L'humidité ou la pluie.
- La lumière directe du soleil.
- La chaleur directe de la climatisation et du chauffage, etc...
- Des substances inflammables dangereuses.
- Sinon, un accident ou un dysfonctionnement.

**Ne pas placer les récipients contenant des produits chimiques ou de l'eau sur ou près de la machine de jeu.**



**Ne placez pas d'objets à proximité des orifices de ventilation.**



**Ne pas plier le cordon d'alimentation par la force ou de placer des objets lourds au-dessus.**



**Ne jamais brancher ou débrancher le cordon d'alimentation avec les mains mouillées.**



**Ne jamais débrancher la machine de jeu en tirant le câble d'alimentation.**



## PRUDENCE

**Veillez à utiliser le câblage intérieur selon les exigences de tension spécifiées. Pour une rallonge, utilisez la notation spécifiée ou plus.**

**Veillez à utiliser le cordon d'alimentation fourni.**

**Ne jamais brancher plus d'un cordon à la fois dans la prise électrique.**



**Ne pas poser le cordon d'alimentation où les gens marchent à travers.**



**Soyez sûr de mettre à la terre ce produit.**



**Ne pas exercer une force excessive lors du déplacement de la machine.**



**Pour une ventilation correcte, garder la machine de jeu 100mm (4 ") loin des murs.**

**Ne pas modifier les réglages des commutateurs DIP liées au système.**





# PRÉCAUTION D'EMPLOI

## ATTENTION

Veillez à éteindre l'interrupteur d'alimentation principale et débranchez le cordon d'alimentation de la prise avant d'inspecter ou de nettoyer la machine. 

Lors du remplacement des pièces, veillez à utiliser une partie des spécifications correctes. Ne jamais utiliser de pièces autres que celles spécifiées. 

L'ouverture à l'intérieur de la machine doit être effectuée par le spécialiste de la machine seulement, comme le courant électrique élevé est transmis à l'intérieur. Pour la machine de jeu avec le moniteur, un soin doit être pris lors de l'ouverture de sa porte arrière. Si non, une détérioration des pièces à l'intérieur ou à l'écran peut se produire. 

Si l'interrupteur secondaire du panneau de service est éteint sans éteindre le commutateur d'alimentation principale de l'unité d'alimentation, certaines parties dans les unités restent sous tension. Lors de l'ouverture de la porte arrière, veillez à éteindre l'interrupteur d'alimentation principale et débranchez le cordon d'alimentation de la prise. 

Il est strictement conseillé de s'abstenir de démonter et de réparer des pièces qui ne sont pas indiqués dans ce manuel, ainsi que les paramètres et le remodelage. 

Pour nettoyer la machine de jeu, l'essuyer avec un chiffon doux imbibé avec un détergent neutre.

- L'utilisation plus mince d'un autre solvant organique ou de l'alcool peut décomposer le matériel.
- Un choc électrique ou une défaillance de l'équipement pourraient être causés par la pénétration de l'eau à l'intérieur de la machine.

## PRUDENCE

Les composants de la machine de jeu sont sensibles aux vibrations et aux chocs. Il faut faire attention lors du déplacement et le transport de la machine de jeu. 

Veillez à ne pas laisser la machine se renverser.

Avant de déplacer la machine, veillez à éteindre l'interrupteur d'alimentation principale, débranchez le cordon d'alimentation de la prise et débranchez le cordon d'alimentation de la machine. 

Avant de déplacer la machine, la mettre hors des niveleurs et le déplacer sur les roulettes.

Éviter une force excessive lors du déplacement de la machine.

.....

## PRÉCAUTIONS LORS DU MANIEMENT

- Lors de la mise en place, l'inspection, l'entretien, déplacement ou le transport de ce produit, suivez les procédures et les instructions énoncées dans ce manuel et effectuer ce travail en toute sécurité.
- Ne pas mettre en place, manipuler, inspecter, entretenir, déplacer ou transporter ce produit dans des conditions équivalentes à l'état de "ATTENTION" ou "PRUDENCE" spécifiée dans ce manuel.
- Si un nouveau propriétaire obtient ce produit à la suite d'un transfert, etc., soyez sûr de donner ce manuel au nouveau propriétaire.

# CONTENTS

1. SPECIFICATION AND DIMENSION	.....P02	6-9. COUNTER HOPPER ERROR	.....P41
1-1. DIMENSION	.....P02	6-10. ELEVATOR HOPPER ERROR	.....P44
1-2. SPECIFICATION	.....P02	6-11. CIRCULATION WIPER ERROR	.....P48
1-3. NAME OF PARTS	.....P03	6-12. CIRCULATION ENCODER SENSOR ERROR	.....P50
1-4. STICKER LOCATION	.....P04	6-13. CIRCULATION MAGNETIC SENSOR PCB ERROR	.....P52
1-5. COMPONENTS	.....P05	6-14. CIRCULATION ERROR	.....P53
2. INSTALLATION	.....P06	6-15. CONVEYER ERROR	.....P55
2-1. INSTALLATION SPACE	.....P06	6-16. CARD DISPENSER ERROR	.....P58
2-2. HOW TO INSTALL [BILLBOARD]	.....P07	6-17. SOUND ERROR	.....P60
2-3. HOW TO INSTALL [COIN & CARD]	.....P08	6-18. COIN SELECTOR ERROR	.....P61
3. GAME CHARACTERISTICS	.....P10	6-19. SETUP BUTTON ERROR	.....P62
4. HOW TO PLAY	.....P10	6-20. COUNTER ERROR	.....P63
5. SETUP SETTING	.....P11	7. EXPLODED VIEW	.....P64
5-1. MACHINE SETUP	.....P11	7-1. MAIN CABINET PART	.....P64
5-2. SETUP MODE	.....P12	7-2. BILLBOARD POP-L FRONT PART	.....P65
5-3. CLEAR MODE	.....P16	7-3. BILLBOARD POP-R FRONT PART	.....P65
5-4. TEST MODE	.....P20	7-4. BILLBOARD_TOTAL PART	.....P66
5-5. ERROR CODE	.....P27	7-5. BONUS FND PART	.....P67
* HOW TO SET ID	.....P29	7-6. SCORE BOARD PANEL PART	.....P68
6. TROUBLESHOOTING	.....P30	7-7. MEDAL CIRCULATION PART	.....P69
6-1. IN CASE OF POWER FAILURE	.....P30	7-8. PUSHER PANEL PART	.....P70
6-2. MEDAL CIRCULATION FND CENTER FND PCB ERROR	.....P32	7-9. FRONT ROLLER PART	.....P71
6-3. TICKETS, TOKENS, BONUS FND PCB ERROR	.....P33	7-10. CARD DISPENSER PART	.....P72
6-4. WHEEL SPIN LED PCB ERROR	.....P34	7-11. ELEVATOR HOPPER PART	.....P73
6-5. BUTTON LED PCB ERROR	.....P35	7-12. COUNTER HOPPER PART	.....P74
6-6. ARC FLEX LED, DOOR LED, TABLE LED, TOP LED ERROR	.....P36	7-13. TICKET DOOR PART	.....P75
6-7. TICKET DISPENSER ERROR	.....P38	7-14. FRONT TABLE PART	.....P76
6-8. IN CASE OF MALFUNCTION OF PUSHER	.....P39	7-15. FRONT DOOR PART	.....P77
		7-16. FRONT GLASS DOOR PART	.....P78
		7-17. AC INPUT PART	.....P79
		7-18. SETUP PANEL PART	.....P79
		7-19. SMPS POWER PART	.....P80
		7-20. MAIN BOARD PCB PART	.....P81
		8. PART PICTURE	.....P82
		9. BLOCK DIAGRAM	.....P87

# 1. SPECIFICATION AND DIMENSION

## 1-1. DIMENSION

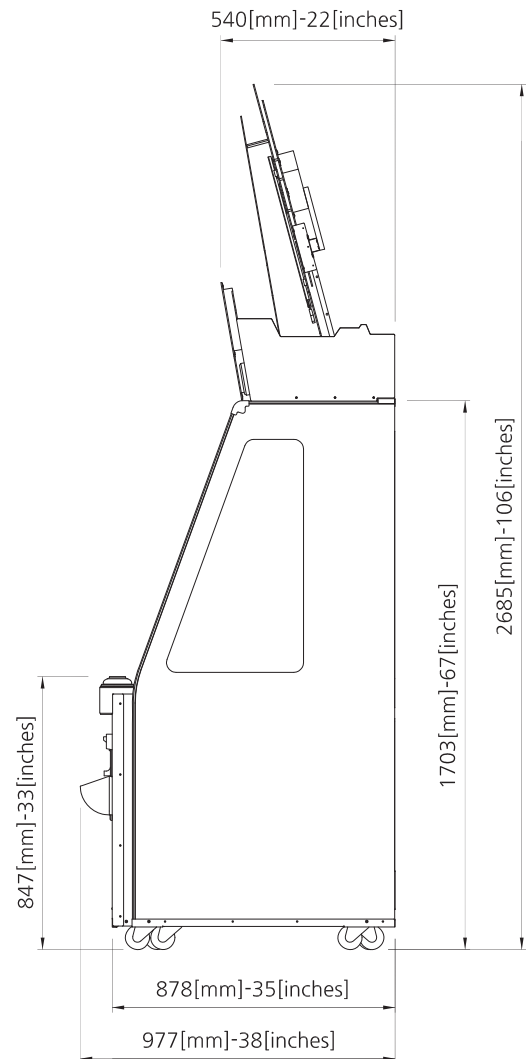
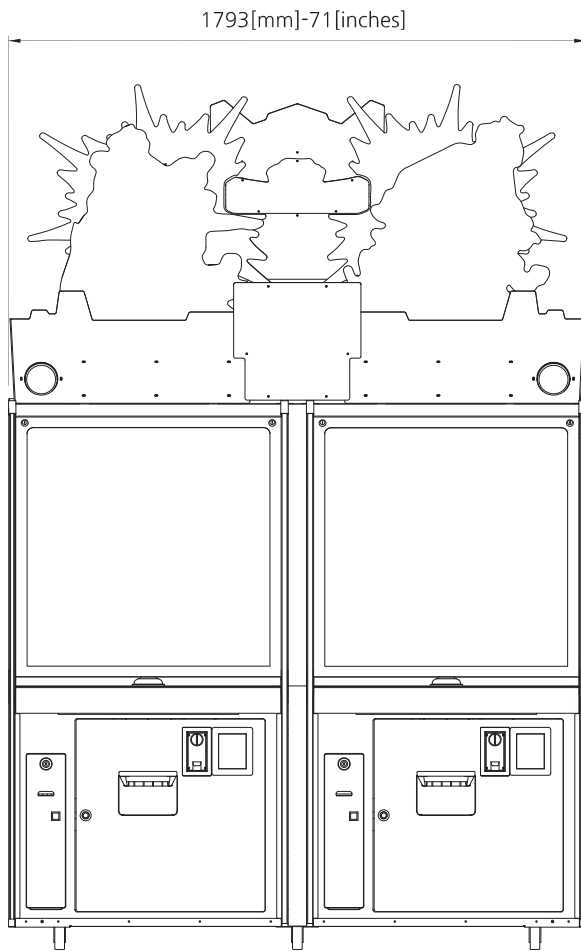
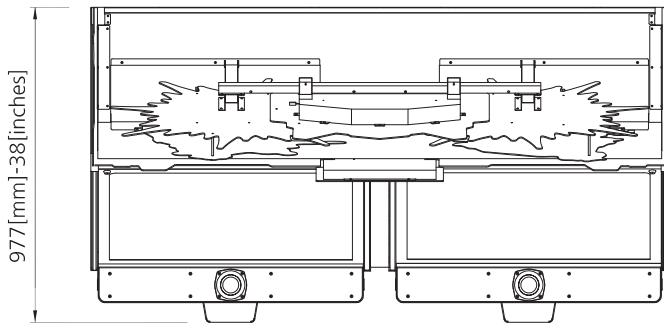

## 1-2. SPECIFICATION

DIMENSION (W x D x H)	1793 x 977 x 2685 (mm)
PACKING DIMENSION (W x D x H)	1150 x 1950 x 2130 (mm)
WEIGHT (kg)	340kg [ WEIGHT INCLUDING : 386 kg ] PACKAGING ]
VOLTAGE	AC 120V
FREQUENCY RANGE	60Hz
CONSUMPTION	360 W

# 1-3. NAME OF PARTS

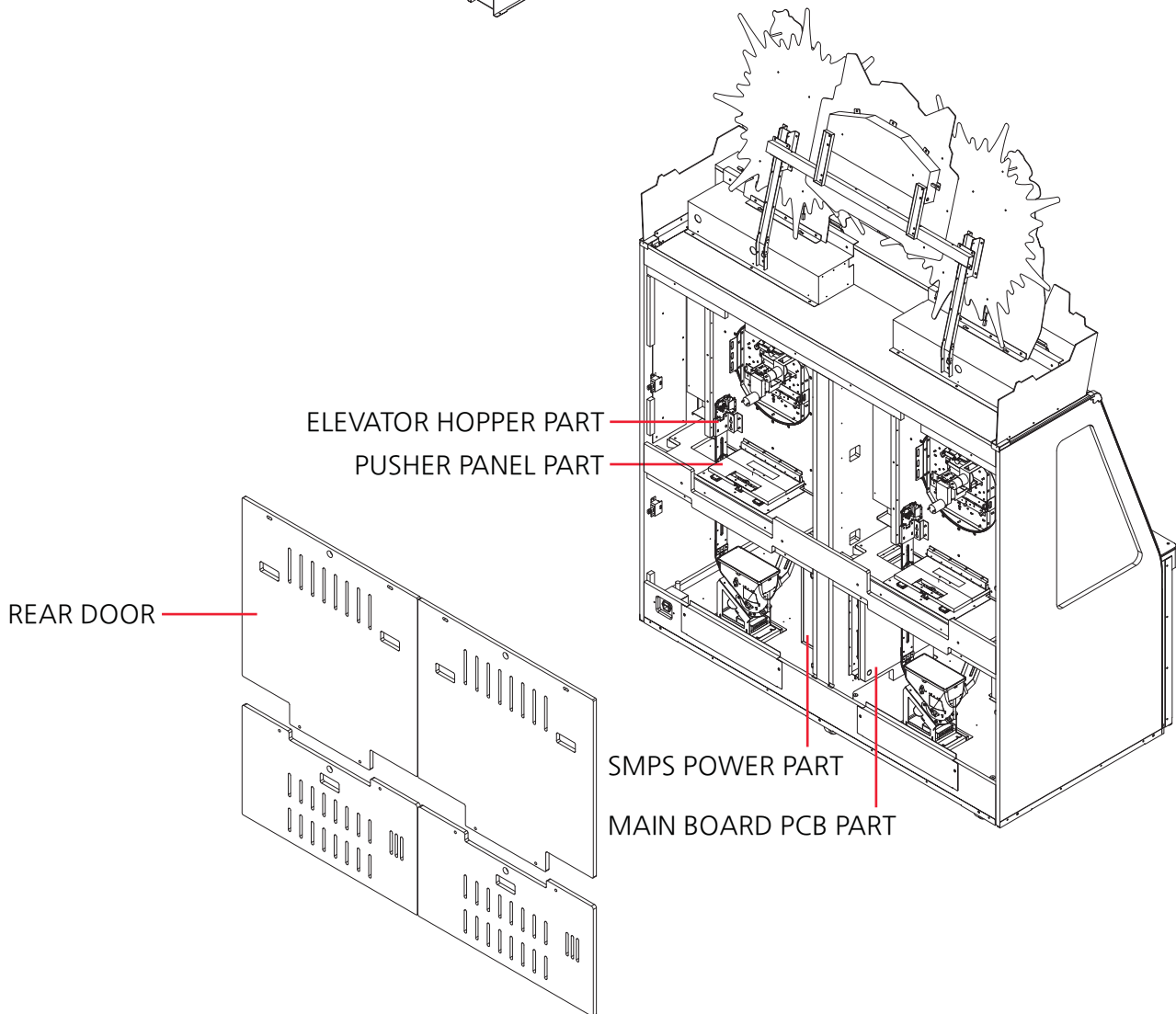
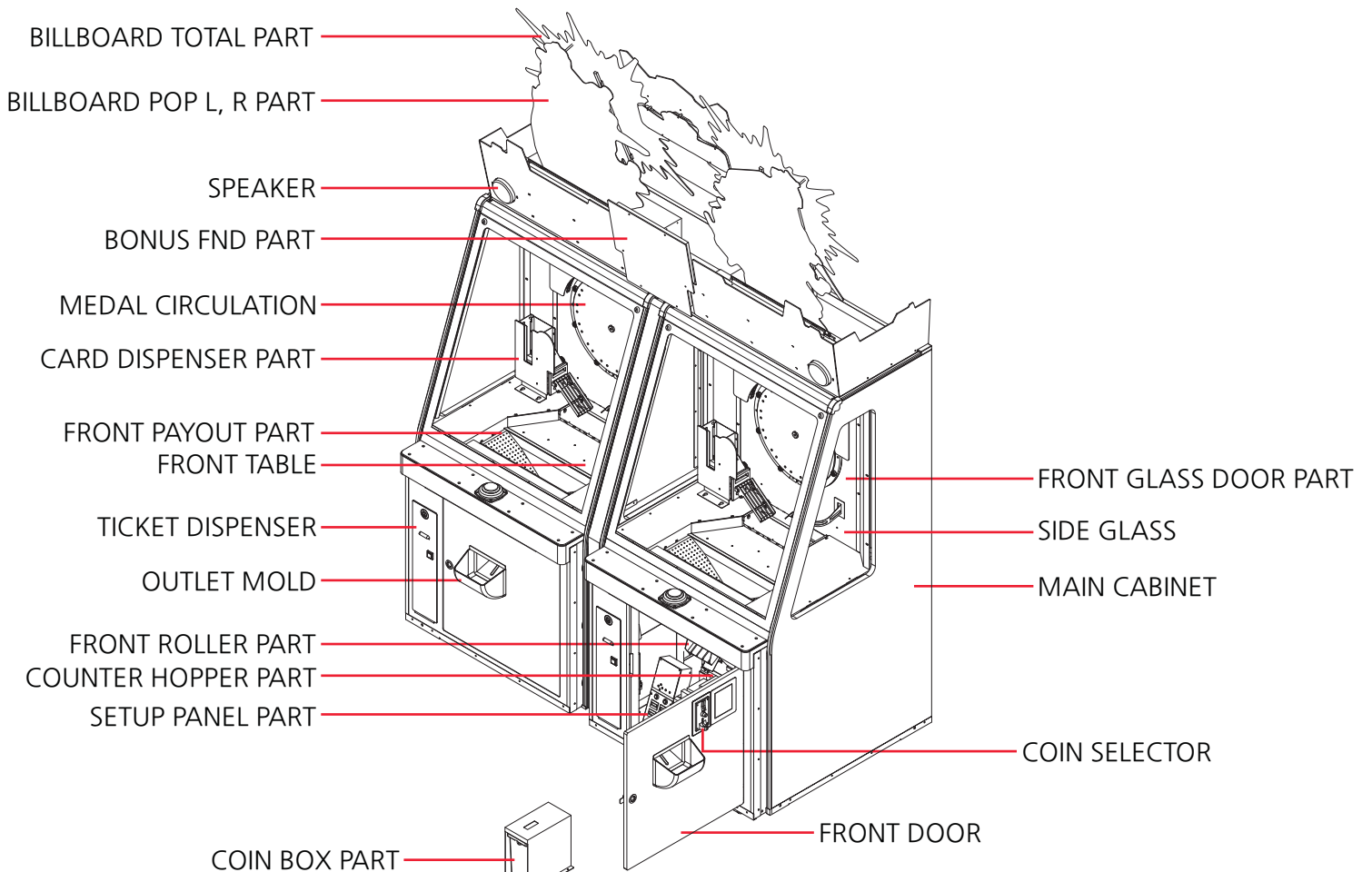

# 1-4. STICKER LOCATION

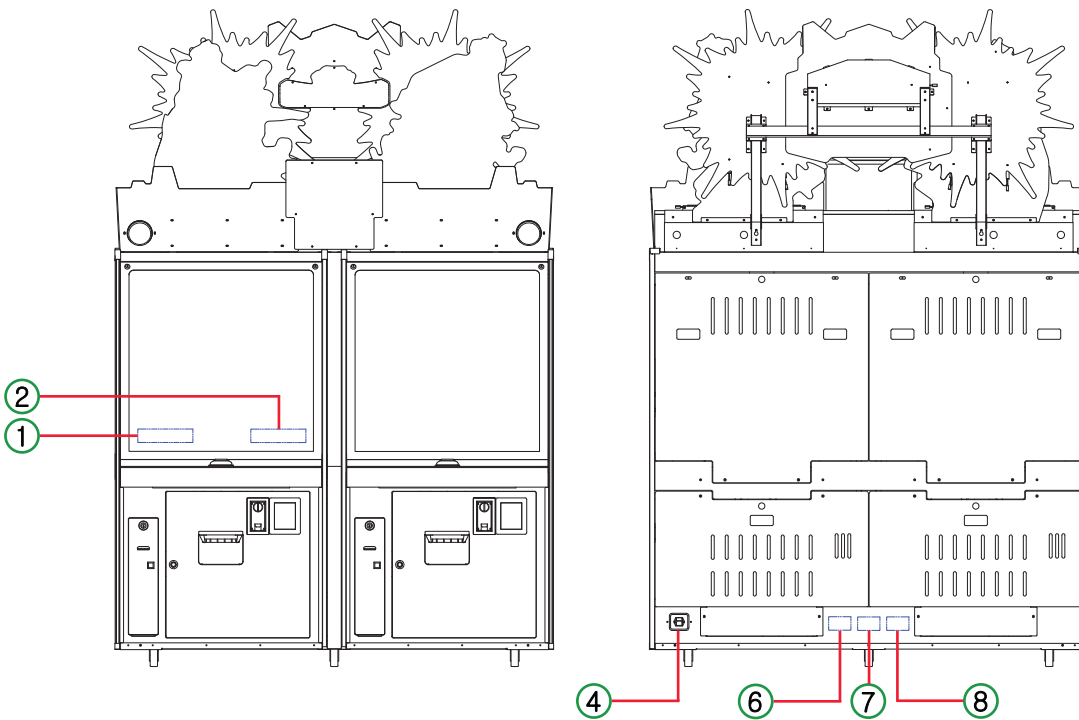
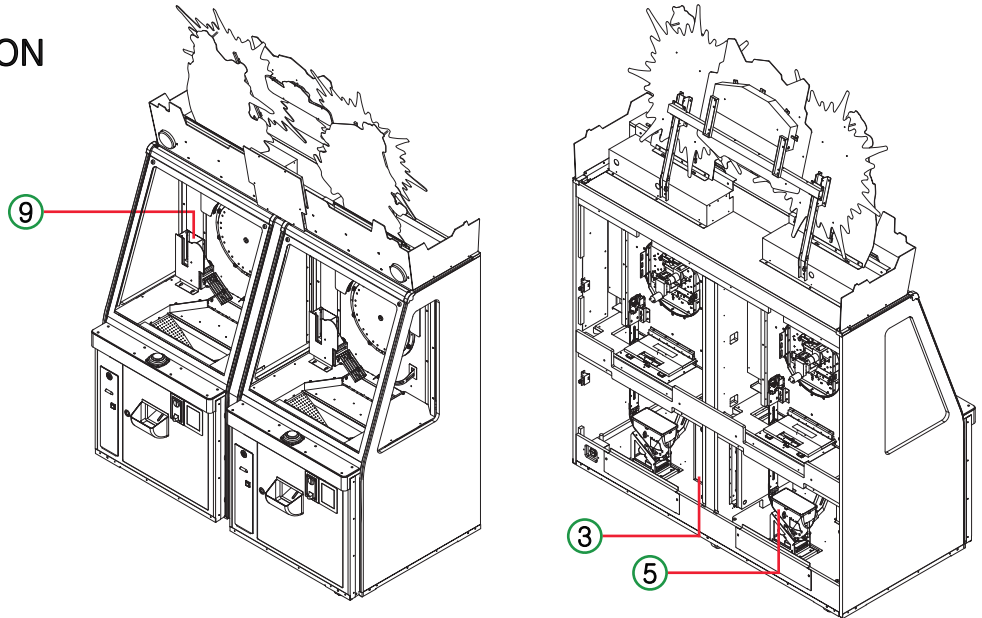

\* limited to 1~2P

1

NOTICE	
	GAME IS EQUIPPED WITH SHAKE ALARM ALARM WILL SOUND IF SHAKEN

2

\* limited to 1~2P

	<b>Do not push or hit this. It would be damaged.</b>
<b>CAUTION/PRUDENCE</b>	<b>Ne pas la pousser ou frapper. Elle serait endommagée.</b>

3

WARNING/ATTENTION	
	Except service personal, please never open the product as there is a risk of electric shock.
	Il y a un risque d'électrocution, n'ouvrez pas le produit excepté le responsable, s'il vous plaît.

4

CAUTION/PRUDENCE	
	"For continuous protection against risk of fire, replace only with the same type 10A-250V fuse"
	"Pour une protection continue contre les risques d'incendie, remplacer un fusible avec seulement le même type 10A-250V"

5

\* limited to 1~2P

NOTICE	
	Please be sure to use the coins supplied by Andamiro. Otherwise, it will cause troubles to operation of hopper.
	To clear out error 06 (ER06), tap the coin hopper by hand, then, push the reset button.

6



7

MODEL NAME	-
PRODUCT S/N	-
MAIN BOX S/N	-
LCD S/N	-
CERTIFICATE	-
MADE IN KOREA	
Koyang-st, Kyunggi-do, Korea Phone:82-81-809-2100	

8

WARNING	
	ROCKING, SHAKING, OR TIPPING MAY CAUSE INJURY OR DEATH! This unit must be fastened securely to the wall, floor or adjacent object in compliance with the installation instructions.
ATTENTION	
	AGITER, SECOUER OU BASCULER PEUT CAUSER DES BLESSURES OU ENTRAINER LA MORT! Cette unité doit être fixée au mur, au plancher ou à un objet à proximité conformément aux instructions d'installation.

9

\* limited to 1~2P

NOTICE	
	Before loading new cards, shuffle all cards properly.

## 1-5. COMPONENTS

NO.	PART NAME	SPEC.	QTY
1	AC POWER CORD	-	1
2	MEDAL	-	2000
3	KEY	6001, 7001	EACH 2
4	BOLT	TH_M4x8L	10
5	BOLT	TH_M4x10L	8
6	BOLT	TH_M4x20L	8
7	BOLT	SEMS_M4x12L	8
8	BOLT	SEMS_M6x30L	12
9	BOLT	TH WRENCH_M4x10L	26
10	WRENCH	2.5, 3, 4mm	EACH 1
11	SHAFT	-	2
12	CARD HEAVY PUSH BKT	-	2
13	CABLE TIE	100mm	5
14	MANUAL	-	1
15	THOUBLESHOOTING MANUAL	-	1

## 2. INSTALLATION

### 2-1. INSTALLATION SPACE

- Need to have installation place.  
Maintenance Zone & Play zone should have at least 2500mm x 2500mm each.

#### IMPORTANT

- Once you set up the machine with required game-play area, when installing this product, set the 4 leg levelers evenly on the floor and make sure that the product is installed stably in a horizontal position. Otherwise the set winning percentage can be twisted.

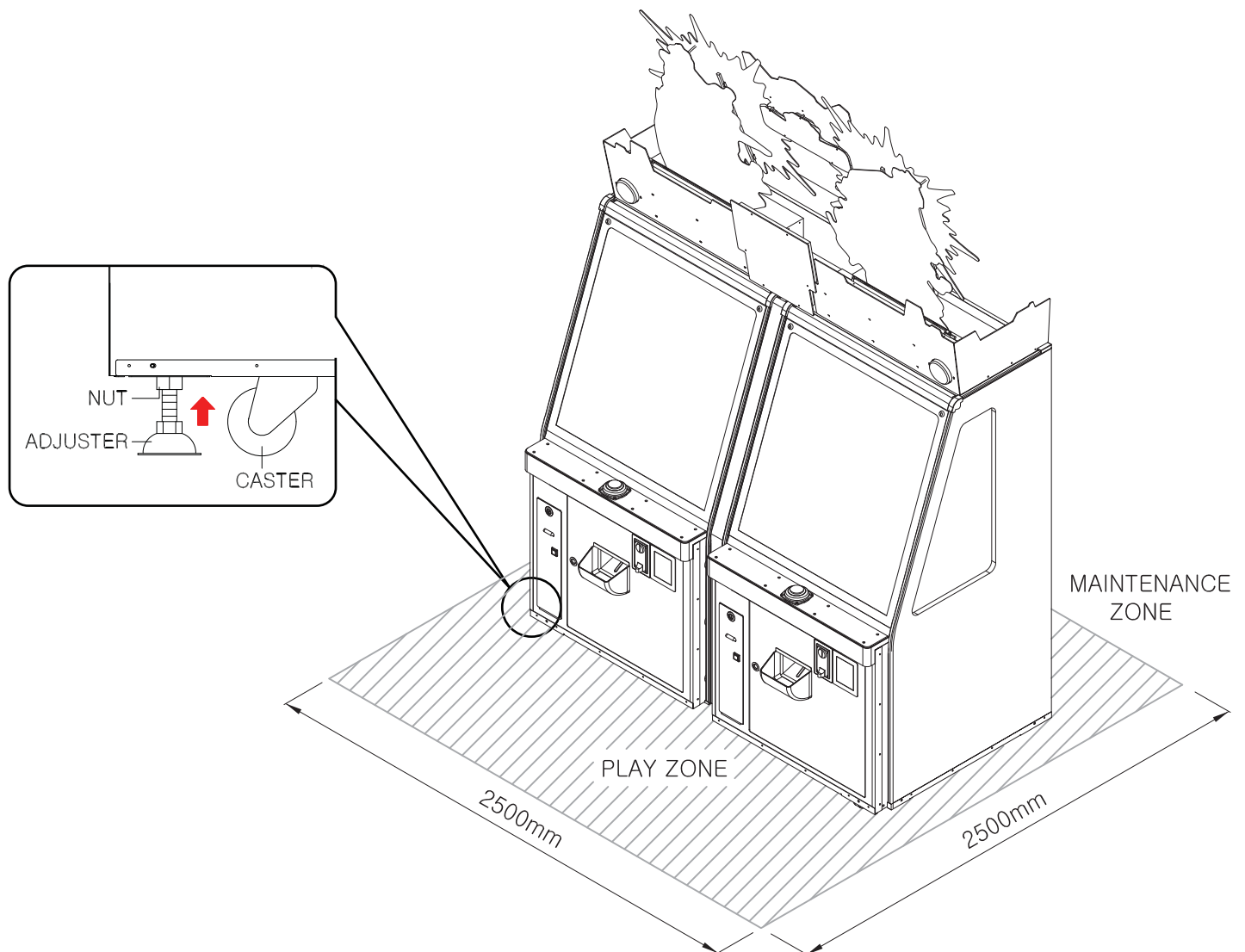

## 2-2. HOW TO INSTALL [BILLBOARD]

1

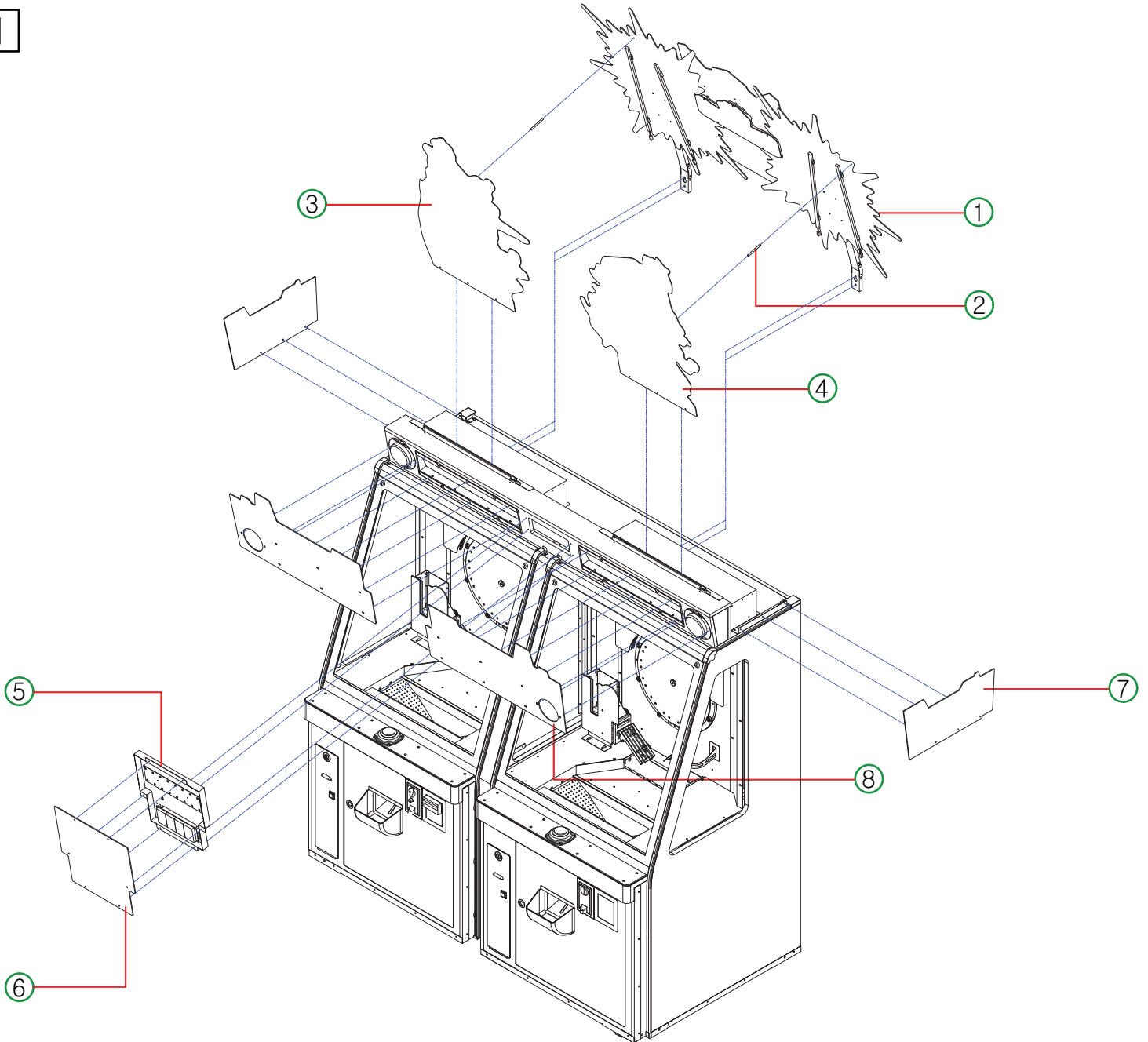

- After unpacking the machine packing, connect billboard and acryl ① ~ ⑥ in sequece as like below diagrams. [ M4 & M6 Bolts ]

\* Connect the connector when assembling ①, ⑤

2

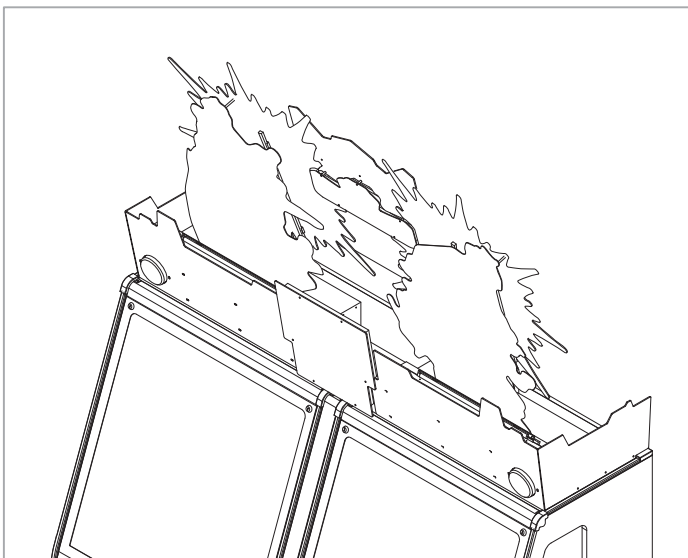

- You complete it like picture.



## 2-3. HOW TO INSTALL [COIN & CARD]

1



- Using by 7001 key, open 1~2P front door and then take out coins after open the coin box using by 6001 key.

2

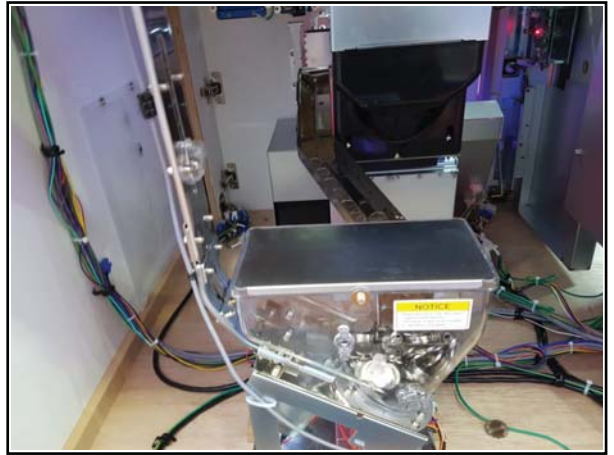

- Detach the cover after unlocking bolts in front and side of elevator hopper cover.
- Put 850 medals each for 1P ~ 2P in Front Hopper.

**\* If you lack a medal, supply 150 medals.**

3

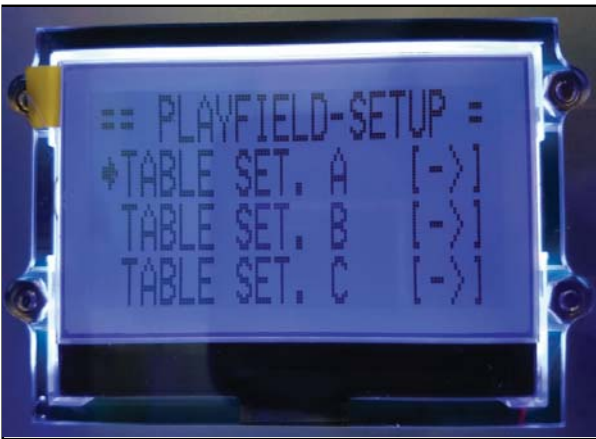

- Then, push select button among SET UP buttons and perform Perform by pushing Select button as OPERATION MENU / PLAYFIELD SETUP / TABLE SET.A in order.

4

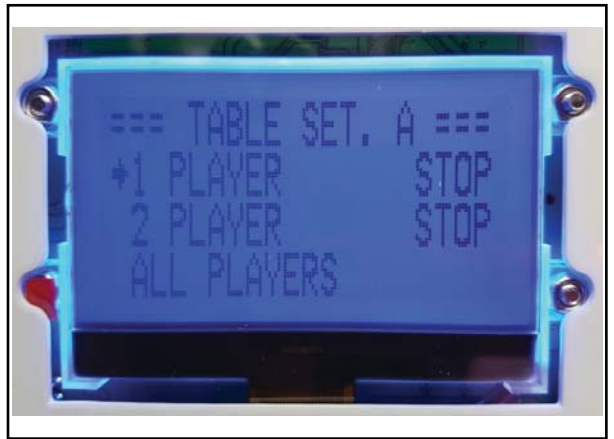

- After selecting 1P ~ 2P PLAYER, supply 1000 coins to PUSHER BASE PANEL by Hopper.

5



- Then, put some of cards, which is included in Accessart Part, onto CARD DISPENSER and then lay H frame to fix it.

6



- Complete the supply of coins and cards as like picture **6**.
- \* On initial setting, put some of cards onto PUSHER BASE PANEL then finish the setting.

7



- On column **6**, Set 10~12 cards above coins supplied on PUSHER BASE PANEL as like the picture.
- Then, maintain 8~10 cards on playing.

**\* 150EA coins inside of extra vinyl packing is spare coins when there is shortage.**

**Please follow the line as the picture when you insert coins to HOPPER.**

**It may cause the problem on operation if you don't follow the above.**

## 3. GAME CHARACTERISTICS

---

**3-1.** World Famous Characters.

**3-2.** Beautifully Styled Cabinet.

**3-3.** LED Lighting.

## 4. HOW TO PLAY

---

\* Players must skillfully time the release of a token through moving targets to drop tokens, win free plays, and score cards that fall over the edge!

# 5. SETUP SETTINGS

## 5-1. MACHINE SETUP

### 1. HOW TO ENTER SETUP MENU

There is "Control panel" inside cabinet. User may set any setting using following.

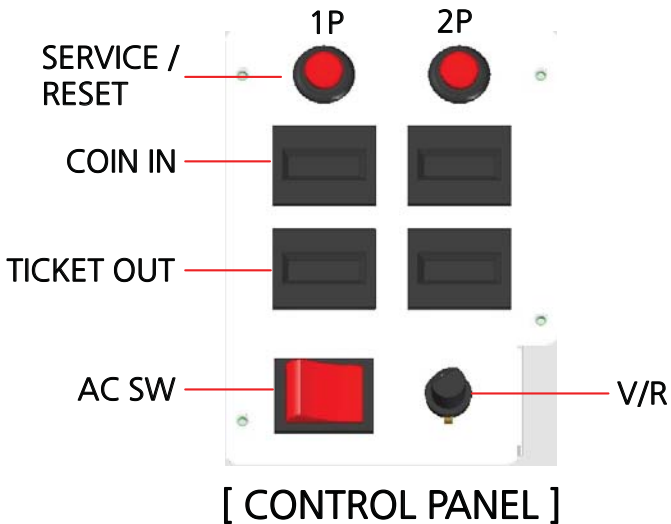

### 2. SETUP BUTTON LAYOUT

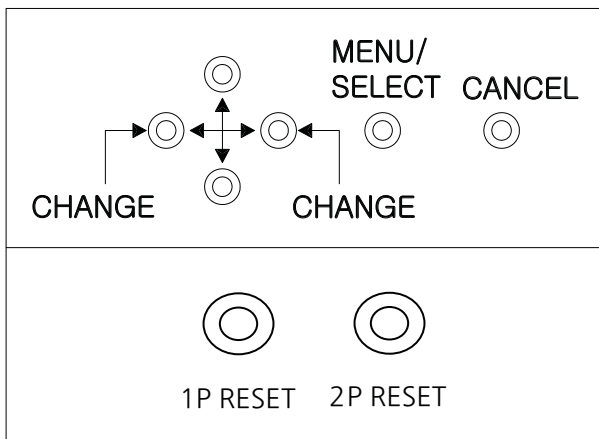

- 1) [ ↑ ↓ ] Up/Down Key : Menu Up/Down move
- 2) [ ← → ] Left/Right Key : Change Setting value
- 3) MENU/SELECT key : Set up Menu mode, Select perform
- 4) CANCEL key : Exit

Normally Service In,  
On ERROR, use to cancel ERROR.  
\* 1Credit per 1 service in

### [ OPERATION MENU ]

PUSH MENU/SELECT	SELECT : ENTER SETUP MODE
	CANCEL : RETURN TO PREVIOUS MENU or EXIT
## OPERATION OPTIONS ##	
PROGRAMSETTING	SETUP MODE FOR EACH MENU
CLEAR MODE	CLEAR MODE FOR DATA
BOOKKEEPING	BOOKKEEPING DATA
FACTORY-SETTING	SET GAMETO FACTORY-SET VALUES
TEST MODE	TEST MODE
PLAYFIELD-SETUP	PUSHER TABLE SETTING
EXIT	RETURN TO THE GAME

## 5-2. SETUP MODE

MENU (LCD DISPLAY)	DESCRIPTION	RANGE	DEFAULT
TICKET/TOKEN	SET TICKET QTY PER TOKEN DROPPED ON COUNT HOPPER	NONE, 0.1, 0.125, 0.2, 0.25, 0.33, 0.5, 1, 2, 3, 4, 5	0.5
PLAYS/COIN	SET PLAYS(CREDITS)QTY PER COIN. IF USING COIN OR SWIPE CARD CONTINUOUSLY WITHOUT PLAY, DIFFERENT PLAY(CREDITS)QTY ARE PAID ACCORDING TO THE CONTINUOUS SWIPING NUMBERS	(REFER TO THE TABLE BELOW)	
PLAYS/BILL	SET PLAYS(CREDITS)QTY PER BILL. DIFFERENT PLAYS(CREDITS)ARE PAID ACCORDING TO THE BILL AMOUNT	(REFER TO THE TABLE BELOW)	
GAMETYPE	CHANGE THE VALUE OF BONUS SPIN LED & CIRCULATION FND	(REFER TO THE TABLE BELOW)	B
HERO BONUS	SET BASIC POINTS OF HERO BONUS	100 ~ 99950 (INCREASED BY 50)	3000
VILLAIN BONUS	SET BASIC POINTS OF VILLAIN BONUS	100 ~ 99950 (INCREASED BY 50)	5000
SUPER BONUS	SET BASIC POINTS OF SUPER BONUS	100 ~ 99950 (INCREASED BY 50)	10000
BONUS DROP SET	SET EACH LAMP POINT OF BONUS DROP	(REFER TO THE TABLE BELOW)	
CIRC. FND SET	SET EACH ZONE POINT OF CIRCULATION FND	(REFER TO THE TABLE BELOW)	
TOKENS/CARD	SET TOKEN QTY TO DROP A CARD ONLY A CARD IS DISPENSED WITHIN SET VALUE WHICH IS TOKEN QTY FROM HOPPER WHEN NO CARD IS DISPENSED WITHIN SET VALUE, A CARD IS AUTOMATICALLY DISPENSED AT THE LAST SET TOKEN	NONE, 50 ~ 500 (INCREASED BY 5)	200
MERCYTICKET	SET MERCYTICKET QTY PER COIN	0 ~ 10 (INCREASED BY 1)	0

DEMO SOUND	SET DEMO SOUND TO ON OR OFF	OFF / ON	ON
SAVE AND EXIT	SAVE SET VALUE AND EXIT	PUSH SELECT BUTTON TO PERFORM	
CANCEL AND EXIT	CANCEL SET VALUE AND EXIT		

● **PROGRAM SETTING** -> PLAYS / COIN

\* SET UP PLAY(CREDITS) PER COIN OR SWIPE.

- IN CASE OF SWIPING THE CARD REPEATEDLY TILL 5 TIMES WITHOUT ANY PLAY, PLAY QTY WILL BE INCREASED AS BELOW.

LCD DISPLAY	DESCRIPTION	RANGE	DEFAULT
MINIMUM COIN	SET MINIMUM COIN QTY FOR PLAY (EXAMPLE IF MINIMUM COIN IS SET TO 5, 1st. COIN > 2 PLAYS : WHEN 5 COINS ARE INSERTED, 2 PLAYS ARE ALLOWED)	1 ~ 9 (INCREASED BY 1)	1
1st. COIN	SET THE NO. OF PLAYS PER COIN WHEN SET TO FREE, FREE PLAY IS ACTIVE	FREE, 1 ~ 500 (INCREASED BY 1)	12
2nd. COIN	SET THE NO. OF PLAYS PER COIN	1 ~ 500 (INCREASED BY 1)	26
3th. COIN	SET THE NO. OF PLAYS PER COIN		42
4th. COIN	SET THE NO. OF PLAYS PER COIN		60
5th. COIN	SET THE NO. OF PLAYS PER COIN		75
SAVE AND EXIT	SAVE SET VALUE AND EXIT		
CANCEL AND EXIT	CANCEL SET VALUE AND EXIT		

● **PROGRAM SETTING** -> PLAYS / BILL SET

\* SET UP PLAY(CREDITS) PER BILL

- THE NO. OF PLAY IS INCREASED ACCORDING TO THE SIGNAL FROM BILL ACCEPTOR

LCD DISPLAY	DESCRIPTION	RANGE	DEFAULT
TYPE	SET "COIN" WHEN BILL SIGNAL IS USED FOR COIN SIGNAL, SET "BILL" WHEN BILL SIGNAL IS USED FOR BILL ACCEPTOR EXAMPLE)SET "COIN" WHEN BILL SIGNAL IS CONNECTED TO COIN SELECTOR	COIN, BILL	BILL
1 BILL	SET THE NO. OF PLAYS FOR \$1.00	1 ~ 3000 (INCREASED BY 1)	12
2 BILLS	SET THE NO. OF PLAYS FOR \$2.00		26
3 BILLS	SET THE NO. OF PLAYS FOR \$3.00		42
4 BILLS	SET THE NO. OF PLAYS FOR \$4.00		60
5 BILLS	SET THE NO. OF PLAYS FOR \$5.00		75
10 BILLS	SET THE NO. OF PLAYS FOR \$10.00		175
20 BILLS	SET THE NO. OF PLAYS FOR \$20.00		400
50 BILLS	SET THE NO. OF PLAYS FOR \$50.00		1000
100 BILLS	SET THE NO. OF PLAYS FOR \$100.00		2000
SAVE AND EXIT	SAVE SET VALUE AND EXIT		
CANCEL AND EXIT	CANCEL SET VALUE AND EXIT		

● **PROGRAM SETTING** ->

GAME TYPE SET (THIS MENU MUST BE SET AFTER FACTORY SETTING)

◇ CHANGE FACTORY-SET VALUE(B) FOR BONUS DROP LED & CIRCULATION FND  
AFTER CHANGING FACTORY-SET VALUE(B), CHOOSE "SAVE" THEN, EXIT AT PROGRAM SETTING

SECTION	BONUS DROP LED							CIRCULATION FND					
	01	02	03	04	05	06	07	01	02	03	04	05	06
A	6	CARD	4	15	4	CARD	6	2	3	1	1	3	2
B	8	CARD	5	15	5	CARD	8	5	3	1	1	3	5
C	8	CARD	4	15	4	CARD	8	2	3	1	1	3	2

● PROGRAM SETTING -> BONUS SPIN SET



◇ CHANGE EACH LAMP POINT ON BONUS DROP LED(LAMP 1~7 FROM THE LEFT)  
 \* NOTE : PAYOUT IS DIFFERENT WHEN CHANGED

LCD DISPLAY	DESCRIPTION	RANGE	DEFAULT
BONUS DROP 1	SET POINTS(TOKENS) ON LAMP 1	1 ~ 99, CARD (INCREASED BY 1)	8
BONUS DROP 2	SET POINTS(TOKENS) ON LAMP 2		CARD
BONUS DROP 3	SET POINTS(TOKENS) ON LAMP 3		5
BONUS DROP 4	SET POINTS(TOKENS) ON LAMP 4		15
BONUS DROP 5	SET POINTS(TOKENS) ON LAMP 5		5
BONUS DROP 6	SET POINTS(TOKENS) ON LAMP 6		CARD
BONUS DROP 7	SET POINTS(TOKENS) ON LAMP 7		8
SAVE AND EXIT	SAVE SET VALUE AND EXIT		
CANCEL AND EXIT	CANCEL SET VALUE AND EXIT		

● PROGRAM SETTING -> CIRC. FND SET



◇ CHANGE EACH ZONE POINT ON CIRCULATION DROP FND (ZONE 1~6 FROM THE LEFT WITHOUT CENTER ZONE)  
 \* NOTE : PAYOUT IS DIFFERENT WHEN CHANGED

LCD DISPLAY	DESCRIPTION	RANGE	DEFAULT
FND 1	SET POINTS(TOKENS) ON ZONE FND 1	1 ~ 9 (INCREASED BY 1)	5
FND 2	SET POINTS(TOKENS) ON ZONE FND 2		3
FND 3	SET POINTS(TOKENS) ON ZONE FND 3		1
FND 4	SET POINTS(TOKENS) ON ZONE FND 4		1
FND 5	SET POINTS(TOKENS) ON ZONE FND 5		3
FND 6	SET POINTS(TOKENS) ON ZONE FND 6		5
SAVE AND EXIT	SAVE SET VALUE AND EXIT		
CANCEL AND EXIT	CANCEL SET VALUE AND EXIT		



### 5-3. CLEAR MODE

● CLEAR MODE CLEAR GAMEDATA AND BOOKKEEPINGDATA		
LCD DISPLAY	DESCRIPTION	PERFORM
CLEAR TICKETS	CLEAR CURRENT PAYABLE TICKETS	SELECT BUTTON
CLEAR PLAYS	CLEAR CURRENT PLAY	CLEAR XXXX DATA
CLEAR HOPPER	CLEAR CURRENT PAYABLE TOKENS (ELEVATOR HOPPER)	ARE YOU SURE?
CLEAR GAMEDATA	CLEAR GAMEDATA & BOOKKEEPING DATA	YES or [NO]
EXIT	EXIT	PERFORM AFTER CURSER MOVING

• BOOKKEEPING	
LCD DISPLAY	DESCRIPTION
---- CARD PER TOKENS --- 1 PLAYER: 50 2 PLAYER: 80	AVERAGE TOKEN QTY PER DISPENSED CARD (TOTAL TOKEN QTY/ TOTAL DISPENSED CARD)
----- COIN IN ----- 1 PLAYER: 12 2 PLAYER: 25	TOTAL COIN IN QTY
----- BILL IN ----- 1 PLAYER: 1 2 PLAYER: 3	TOTAL BILL IN QTY ACCUMULATED INPUT PULSE QTY
----SERVICE IN---- 1 PLAYER: 5 2 PLAYER: 10	TOTAL SERVICE IN QTY
----- PLAY IN ----- 1 PLAYER: 20 2 PLAYER: 100	TOTAL PLAY QTY
----- TICKET OUT ----- 1 PLAYER: 730 2 PLAYER: 960	TOTAL TICKET OUT QTY
---- CARD DISPENSER ---- 1 PLAYER: 1 2 PLAYER: 4	TOTAL CARD OUT QTY FROM CARD DISPENSER
---- ELEVATOR HOPPER ---- 1 PLAYER: 200 2 PLAYER: 400	TOTAL TOKEN-OUT QTY FROM ELEVATOR HOPPER
---- COUNTER HOPPER ---- 1 PLAYER: 50 2 PLAYER: 100	TOTAL TOKEN-OUT QTY FROM COUNTER HOPPER

<p>----- BONUS DROP 1 -----</p> <p>1 PLAYER: 11</p> <p>2 PLAYER: 13</p>	THE TOTAL NO. OF BONUS DROP 1
<p>----- BONUS DROP 2 -----</p> <p>1 PLAYER: 21</p> <p>2 PLAYER: 23</p>	THE TOTAL NO. OF BONUS DROP 2
<p>----- BONUS DROP 3 -----</p> <p>1 PLAYER: 31</p> <p>2 PLAYER: 33</p>	THE TOTAL NO. OF BONUS DROP 3
<p>----- BONUS DROP 4 -----</p> <p>1 PLAYER: 41</p> <p>2 PLAYER: 43</p>	THE TOTAL NO. OF BONUS DROP 4
<p>----- BONUS DROP 5 -----</p> <p>1 PLAYER: 51</p> <p>2 PLAYER: 53</p>	THE TOTAL NO. OF BONUS DROP 5
<p>----- BONUS DROP 6 -----</p> <p>1 PLAYER: 61</p> <p>2 PLAYER: 63</p>	THE TOTAL NO. OF BONUS DROP 6
<p>----- BONUS DROP 7 -----</p> <p>1 PLAYER: 71</p> <p>2 PLAYER: 73</p>	THE TOTAL NO. OF BONUS DROP 7
<p>---- CIRCULATION DROP ----</p> <p>1 PLAYER: 11</p> <p>2 PLAYER: 13</p>	THE TOTAL NO. OF BONUS DROP (CENTER) IN CIRCULATION
<p>----- CIRCULATION 1 -----</p> <p>1 PLAYER: 21</p> <p>2 PLAYER: 23</p>	THE TOTAL NO. OF CIRCULATION FND 1
<p>----- CIRCULATION 2 -----</p> <p>1 PLAYER: 31</p> <p>2 PLAYER: 33</p>	THE TOTAL NO. OF CIRCULATION FND 2
<p>----- CIRCULATION 3 -----</p> <p>1 PLAYER: 41</p> <p>2 PLAYER: 43</p>	THE TOTAL NO. OF CIRCULATION FND 3
<p>----- CIRCULATION 4 -----</p> <p>1 PLAYER: 51</p> <p>2 PLAYER: 53</p>	THE TOTAL NO. OF CIRCULATION FND 4

----- CIRCULATION 5 ----- 1 PLAYER: 61 2 PLAYER: 63	THE TOTAL NO. OF CIRCULATION FND 5
----- CIRCULATION 6 ----- 1 PLAYER: 71 2 PLAYER: 73	THE TOTAL NO. OF CIRCULATION FND 6
--T. ELEVATOR HOPPER-- 1 PLAYER: 222 2 PLAYER: 444	TOTAL QUANTITY EMITTED TO HOPPER ELEVATOR (It is not cleared by FACTORY SETTING)
--T. COUNTER HOPPER -- 1 PLAYER: 456 2 PLAYER: 50	TOTAL QUANTITY EMITTED TO COUNTER ELEVATOR (It is not cleared by FACTORY SETTING)
----- VER INFO -----	DISPLAY VERSION INFO
CANCEL BUTTON : RETURN TO PREVIOUS MENU	

● FACTORY-SETTING INITIALIZE TO FACTORY-SET VALUE (CLEAR TOTAL DATA AND RETURN TO FACTORY-SET VALUE)	
LCD DISPLAY (PERFORM)	LCD DISPLAY (PERFORM)
FACTORY-SETTING ARE YOU SURE? YES or [NO] PERFORM AFTER THE CURSER MOVES	FACTORY-SETTING REALLY? YES or [NO] PERFORM AFTER THE CURSER MOVES

## 5-4. TEST MODE

● TEST MODE		
LCD DISPLAY	STATUS	DESCRIPTION
INPUT TEST	(REFER TO THE TABLE BELOW)	TEST INPUT SIGNAL
LED&FND&LAMP	OFF/ON/STEP ON/OFF	TEST THE STATUS OF LED&FND&LAMP OFF : TOTAL OFF ON : TOTAL ON STEP : ACT ACCORDING TO THE SPECIFIED SEQUENCE ON/OFF : ON AND OFF OPERATE CONSTANTLY
CIRCULATION 1 PLAYER           OFF 2 PLAYER           OFF ALL PLAYERS TEST VIEW EXIT	OFF/ON (DISPLAY OF OPERATION STAUS)	TEST CIRCULATION AND WIPER TICKET FND : DISPLAY THE STATUS OF WIPER SENSOR PLAYS FND : DISPLAY THE STATUS OF UPPER TOKEN SENSOR IN CIRCULATION TARGET FND : DISPLAY THE STATUS OF EACH ZONE SENSOR IN CIRCULATION TEST VIEW : DISPLAYS THE NUMBER OF TIMES EACH SENSOR HAS ENTERED
PUSHER 1 PLAYER           OFF 2 PLAYER           OFF ALL PLAYERS EXIT	OFF/ON (DISPLAY OF OPERATION STAUS)	TEST PUSHER MOTOR MOVEMENT TICKET FND : DISPLAY THE STATUS OF PUSHER MOTOR
ELEVATOR HOPPER 1 PLAYER           OFF 2 PLAYER           OFF EXIT	OFF/ON (DISPLAY OF OPERATION STAUS)	TEST THE MOVEMENT OF ELEVATOR HOPPER AFTER DISPENSING 3 TOKENS, STOP AUTOMATICALLY TICKET FND : DISPLAY THE STATUS OF SENSOR PLAY FND : THE NO. OF DISPENSED TOKENS
COUNTER HOPPER 1 PLAYER           OFF 2 PLAYER           OFF EXIT	OFF/ON (DISPLAY OF OPERATION STAUS)	TEST THE MOVEMENT OF COUNTER HOPPER AFTER DISPENSING 3 TOKENS, STOP AUTOMATICALLY TICKET FND : DISPLAY THE STATUS OF SENSOR PLAY FND : THE NO. OF DISPENSED TOKEN

CARD DISPENSER 1 PLAYER            OFF 2 PLAYER            OFF EXIT	OFF/ON (DISPLAY OF OPERATION STAUS)	TEST THE MOVEMENT OF CARD DISPENSER ON TESTING, THIS DISPENSES A CARD AND STOPS AUTOMATICALLY TICKET FND : DISPLAYS THE STATUS OF SENSOR
CONVEYER 1 PLAYER            OFF 2 PLAYER            OFF ALL PLAYERS EXIT	OFF/ON (DISPLAY OF OPERATION STAUS)	TEST THE MOVEMENT OF CONVEYER TICKET FND : DISPLAYS THE STATUS OF SENSOR
TICKET 1 PLAYER            OFF 2 PLAYER            OFF EXIT	OFF/ON (DISPLAY OF OPERATION STAUS)	TEST THE MOVEMENT OF TICKET DISPENSER ON TESTING, THIS DISPENSES 3 TICKETS AND STOPS AUTOMATICALLY TICKET FND : THE NO. OF DISPENSED TICKETS
COIN 1 PLAYER            OFF 2 PLAYER            OFF EXIT	OFF/ON (DISPLAY OF OPERATION STAUS)	TEST OF COIN SELECTOR ON TESTING, CHECK POWER-ON/OFF OF COIN SELECTOR TICKET FND : THE NO. OF INSERTED COINS
COUNTER 1 PLAYER    0        0 2 PLAYER    0        0 EXIT	DISPLAY COUNTER SIGNAL	TEST COUNTER LEFT BUTTON : INCREASES 1 ON COIN COUNTER RIGHT BUTTON : INCREASES 1 ON TICKET COUNTER
SOUND	(REFER TO THE TABLE BELOW)	SOUND TEST
EXIT	EXIT TO PREVIOUS MENU	

● TEST MODE -> INPUT TEST		
LCD DISPLAY		DESCRIPTION
1P	INPUT TEST	2P
000000		000000
00000000	0	00000000
00000000		00000000
00000000		00000000
DESCRIPTION (1P, 2P INPUT TEST IS SAME AS 1P INPUT TEST.)		
000000	1. COIN SENSOR 2. BILL SENSOR 3. TICKET SENSOR 4. TICKET BUTTON 5. 1P RESET BUTTON 6. 2P RESET BUTTON	
00000000	1. START BUTTON 2. CONVEYER SENSOR 3. CARD OUT SENSOR 4. PUSHER SENSOR 5. COUNTER HOPPER SENSOR 6. ELEVATOR HOPPER SENSOR 7. CARD DISPENSER SENSOR 8. CIRCULATION WIPER SENSOR	
00000000	1.CIRCULATION TOP SENSOR 2.CIRCULATION 1 SENSOR 3. CIRCULATION 2 SENSOR 4. CIRCULATION 3 SENSOR 5. CIRCULATION 3 SENSOR 6. CIRCULATION 4 SENSOR 7. CIRCULATION 5 SENSOR 8. CIRCULATION 6 SENSOR	
00000000	1. DIP SWITCH_1 2. DIP SWITCH_2 3. DIP SWITCH_3 4. DIP SWITCH_4 5. DIP SWITCH_5 6. DIP SWITCH_6 7. DIP SWITCH_7 8. DIP SWITCH_8	

● TEST MODE -> SOUND		
LCD DISPLAY	CONFIGURATION	EXPLANATION
CHANNEL STOP 1	1 ~ 8	CHANNEL TEST From 1 to 8
SOUND 1 STOP AUTO	AUTO 1 ~ 88	SELECT THE DESIRED SOUND NUMBER WITH THE RIGHT OR LEFT BUTTON AND PRESS THE SELECT BUTTON TO SELECT THE SOUND OUTPUT. AUTO : Output overall SOUND sequentially 1 ~ 88 : Output desired SOUND
EXIT	EXIT TO SOUND TEST	

● PLAYFIELD-SETUP

◇ ON FIRST SETTING UP THE MACHINE AT A LOCATION, EXECUTE TABLE SET WITH SUPPLIED TOKENS FILLED IN THE ELEVATOR HOPPER

LCD DISPLAY	DESCRIPTION	PERFORM
TABLE SET. A	ON FIRST SETTING UP THE MACHINE A LOCATION (REFER TO TABLE 7)	PUSH SELECT BUTTON AND PERFORM
TABLE SET. B	ON ROUTINE TESTING THE MACHINE. (REFER TO TABLE 8)	
TABLE SET. C	ON ROUTINE TESTING THE MACHINE. (REFER TO TABLE 9)	
EXIT	RETURN TO PREVIOUS MENU	

● PLAYFIELD-SETUP -> TABLE SET. A PERFORM

◇ ON FIRST SETTING UP THE MACHINE AT A LOCATION, EXECUTE TABLE SET. A AS BELOW.

- ① FILL 1,000 TOKENS IN EACH ELEVATOR HOPPER
- ② ENTER TABLE SET A AND SELECT 1P, 2P
- ③ 1,000 TOKENS ARE AUTOMATICALLY LAUNCHED
- ④ WHEN 900 TOKENS ARE LAUNCHED, PUSHER TABLE TOKENS ARE READY TO PLAY

LCD DISPLAY	DESCRIPTION	PERFORM
PUSHER TABLE SET. A 1 PLAYER          STOP 2 PLAYER          STOP ALL PLAYERS	SELECT AND PERFORM PERFORM ONLY 1P PERFORM ONLY 2P PERFORM 1P, 2P	PUSH SELECT BUTTON AND PERFORM
EXIT	RETURN TO PREVIOUS MENU	

● PLAYFIELD-SETUP -> TABLE SET. B PERFORM

◇ ROUTINE FUNCTION TEST ON MANUFACTURING (AGING TEST)

3,000 PLAYS ARE AUTOMATICALLY PERFORMED WITH CARDS/TICKETS DISPENSED

LCD DISPLAY	DESCRIPTION	PERFORM
PUSHER TABLE SET. B 1 PLAYER          STOP 2 PLAYER          STOP ALL PLAYERS	SELECT AND PERFORM PERFORM ONLY 1P PERFORM ONLY 2P PERFORM 1P, 2P	PUSH SELECT BUTTON AND PERFORM
BOOKKEEPING	CHECK INTERNAL DATA DURING PERFORMING TABLE SET. B (REFER TO BOOKKEEPING DATA 1 BELOW)	
EXIT	RETURN TO PREVIOUS MENU	



● PLAYFIELD-SETUP -> TABLE SET. C PERFORM

◇ ROUTINE FUNCTION TEST ON MANUFACTURING (LONG-TERM AGING TEST)  
 100,000PLAYS ARE AUTOMATICALLYPERFORMED WITH CARDS/TICKETS DISPENSED  
 BUT, WHEN CARDS ARE NOT DISPENSED, ERROR CODE DOESN'T APPEAR

LCD DISPLAY	DESCRIPTION	PEFORM
PUSHER TABLE SET. C 1 PLAYER STOP 2 PLAYER STOP ALL PLAYERS	SELECT AND PERFORM PERFORM ONLY 1P PERFORM ONLY 2P PERFORM 1P, 2P	
BOOKKEEPING	CHECK INTERNAL DATA DURING PERFORMING TABLE SET. B (REFER TO BOOKKEEPINGDATA 1 BELOW)	
EXIT	RETURN TO PREVIOUS MENU	

● PLAYFIELD TEST DATA ON PLAYFIELD-SETUP

LCD DISPLAY	DESCRIPTION
---- CARD PER TOKENS --- 1 PLAYER: 50 2 PLAYER: 80	AVERAGETOKEN QTY PER DISPENSED CARD (TOTAL TOKEN QTY/ TOTAL DISPENSED CARD)
----- PLAY IN ----- 1 PLAYER: 20 2 PLAYER: 100	TOTAL PLAY QTY
----- TICKET OUT ----- 1 PLAYER: 730 2 PLAYER: 960	TOTAL TICKET OUT QTY
---- CARD DISPENSER ---- 1 PLAYER: 2 2 PLAYER: 4	TOTAL CARD OUT QTY FROM CARD DISPENSER
--- ELEVATOR HOPPER --- 1 PLAYER: 200 2 PLAYER: 400	TOTAL TOKEN-OUT QTY FROM ELEVATOR HOPPER

<p>---- COUNTER HOPPER ----</p> <p>1 PLAYER: 100</p> <p>2 PLAYER: 50</p>	TOTAL TOKEN-OUT QTY FROM COUNTER HOPPER.
<p>----- BONUS DROP1 -----</p> <p>1 PLAYER: 11</p> <p>2 PLAYER: 13</p>	THE TOTAL NO. OF BONUS DROP 1
<p>----- BONUS DROP2 -----</p> <p>1 PLAYER: 21</p> <p>2 PLAYER: 23</p>	THE TOTAL NO. OF BONUS DROP 2
<p>----- BONUS DROP3 -----</p> <p>1 PLAYER: 31</p> <p>2 PLAYER: 33</p>	THE TOTAL NO. OF BONUS DROP 3
<p>----- BONUS DROP4 -----</p> <p>1 PLAYER: 41</p> <p>2 PLAYER: 43</p>	THE TOTAL NO. OF BONUS DROP 4
<p>----- BONUS DROP5 -----</p> <p>1 PLAYER: 51</p> <p>2 PLAYER: 53</p>	THE TOTAL NO. OF BONUS DROP 5
<p>----- BONUS DROP6 -----</p> <p>1 PLAYER: 61</p> <p>2 PLAYER: 63</p>	THE TOTAL NO. OF BONUS DROP 6
<p>----- BONUS DROP7 -----</p> <p>1 PLAYER: 71</p> <p>2 PLAYER: 73</p>	THE TOTAL NO. OF BONUS DROP 7
<p>---- CIRCULATION DROP ----</p> <p>1 PLAYER: 11</p> <p>2 PLAYER: 13</p>	THE TOTAL NO. OF BONUS DROP (CENTER) IN CIRCULATION
<p>----- CIRCULATION 1 -----</p> <p>1 PLAYER: 21</p> <p>2 PLAYER: 23</p>	THE TOTAL NO. OF CIRCULATION FND 1
<p>----- CIRCULATION 2 -----</p> <p>1 PLAYER: 31</p> <p>2 PLAYER: 33</p>	THE TOTAL NO. OF CIRCULATION FND 2
<p>----- CIRCULATION 3 -----</p> <p>1 PLAYER: 41</p> <p>2 PLAYER: 43</p>	THE TOTAL NO. OF CIRCULATION FND 3
<p>----- CIRCULATION 4 -----</p> <p>1 PLAYER: 51</p> <p>2 PLAYER: 53</p>	THE TOTAL NO. OF CIRCULATION FND 4

----- CIRCULATION 5 ----- 1 PLAYER:        61 2 PLAYER:        63	THE TOTAL NO. OF CIRCULATION FND 5
----- CIRCULATION 6 ----- 1 PLAYER:        71 2 PLAYER:        73	THE TOTAL NO. OF CIRCULATION FND 6
CANCEL : RETURN TO PREVIOUS MENU.	

◆ **NOMAL LCD DISPLAY BEFORE ENTERING OPERATION MENU(MODE)**

BOOKKEEPING DATA		CONFIRM WITH [↑ ↓] BUTTON
LCD DISPLAY	DESCRIPTION	
---- CARD PER TOKENS --- 1 PLAYER:        50 2 PLAYER:        80	AVERAGE TOKEN QTY PER DISPENSED CARD (TOTAL TOKEN QTY/ TOTAL DISPENSED CARD)	
----- COIN IN ----- 1 PLAYER:        12 2 PLAYER:        25	TOTAL COIN IN. QTY	
----- BILL IN ----- 1 PLAYER:        1 2 PLAYER:        3	TOTAL BILL IN. QTY ACCUMULATED INPUT PULSE QTY	
----- SERVICE IN ----- 1 PLAYER:        5 2 PLAYER:        10	TOTAL SERVICE IN. QTY	
----- PLAY IN ----- 1 PLAYER:        20 2 PLAYER:        100	TOTAL PLAY QTY	
----- TICKET OUT ----- 1 PLAYER:        730 2 PLAYER:        960	TOTAL TICKET OUT QTY	
-- CARD DISPENSER -- 1 PLAYER:        2 2 PLAYER:        4	TOTAL CARD OUT QTY FROM CARD DISPENSER	
---- ELEVATOR HOPPER --- 1 PLAYER:        200 2 PLAYER:        400	TOTAL TOKEN-OUT QTY FROM ELEVATOR HOPPER	
---- COUNTER HOPPER ---- 1 PLAYER:        50 2 PLAYER:        100	TOTAL TOKEN-OUT QTY FROM COUNTER HOPPER	

## 5-5. ERROR CODE

CODE ( TOKENS FND )	CONTENTS	ERROR DESCRIPTION (REBOOTING AFTER TROUBLE SHOOTING)
E.02	COIN ERROR	1. COIN JAM ( 'COIN JAM' Trouble shooting in the coin acceptor )
E.03	CIRCULATION ERROR	1. CIRCULATION MEDAL JAM INSIDE OR NO MEDAL ( Remove the acrylic plate OR Pull down jammed medal using magnet outside of acrylic plate ) 2. MALFUNCTION OF UPPER SENSOR ( TEST MODE -> CIRCULATION TEST : Check Circulator's operation )
E.04	PUSHER ERROR	1. MALFUNCTION OF AC MOTOR OR SENSOR ( TEST MODE -> PUSHER TEST : Check MOTOR's operation ) 2. MEDAL JAM at the PUSHER's bottom part or either side of upper part.
E.05	COUNTER HOPPER ERROR	1. MALFUNCTION OF MOTOR OR SENSOR ( TEST MODE -> COUNTER HOPPER TEST : Check operation ) 2. CONVEYER Check operation ( TEST MODE -> CONVEYER TEST Check operation )
E.06	ELEVATOR HOPPER ERROR	1. MALFUNCTION OF MOTOR OR SENSOR ( TEST MODE -> ELEVATOR HOPPER TEST Check operation ) 2. NO MEDAL IN THE ELEVAOTR HOPPER ( Check MEDAL was dropped around. ) 3. MEDAL JAM AT THE RAIL WHERE MEDAL WAS EMITTED ( Remove MEDAL at the RAIL ) 4. Check COUNTER HOPPER's operation ( TEST MODE -> COUNTER HOPPER TEST : Check operation ) 5. Check CONVEYER's operation ( TEST MODE -> CONVEYER TEST : Check operation ) 6. In case of MEDAL wasn't emitted even though there is MEDAL in the ELEVAOTR HOPPER ( Tap the bucket lightly several times. )
E.07	CIRCULATION WIPER ERROR	1. MALFUNCTION OF MOTOR OR SENSOR ( TEST MODE -> CIRCULATION TEST : Check operation )
E.08	CONVEYER ERROR	1. MALFUNCTION OF MOTOR OR SENSOR ( TEST MODE -> CONVEYER TEST : Check operation ) 2. MEDAL JAM at the bottom part or upper part.

<b>E.08</b>	<b>CONVEYER ERROR</b>	1. MALFUNCTION OF MOTOR OR SENSOR ( TEST MODE -> CONVEYER TEST : Check operation ) 2. MEDAL JAM at the bottom part or upper part. ( TROBLE SHOOTING MEDAL JAM )
<b>E.09</b>	<b>CIRCULATION ENCODER SENSOR ERROR</b>	1. MALFUNCTION OF MOTOR OR ENCODER SENSOR ( TEST MODE -> CIRCULATION TEST : Check operation ) 2. Check the clearance of the acrylic panel. ( Adjust to spin it by hand and the clearance is less than 2cm )
<b>E.10</b>	<b>CIRCULATION MAGNETIC SENSOR PCB ERROR</b>	1. MALFUNCTION OF SENSOR PCB in the bottom part of CIRCULATION ( TEST MODE -> CIRCULATION TEST : Check operation )
<b>E.11</b>	<b>CARD DISPENSER ERROR</b>	1. CARD EMPTY 2. CARD JAM ( CARDS need to be shuffled when it put and lay in the H frame. )
<b>E.12</b>	<b>BILL ACCEPT ERROR</b>	1. Signal outputs consistently from the Bill Acceptor. (Check the Bill Acceptor)
<b>E.20</b>	<b>SETUP LCD ERROR</b>	1. MALFUNCTION OF SETUP LCD ( Check the connection of MAIN BOARD connector )
<b>E.21</b>	<b>CONNECT ERROR</b>	1. MALFUNCTION OF COMMUNICATION CONNECTION ( Check the DIP-SWITCH ID of MAIN BOARD or connector line. )
<b>E.22</b>	<b>PROGRAM VERSION ERROR</b>	1. MISMATCH ON EACH MAIN BOARD OF PROGRAM VERSION
<b>E.23</b>	<b>BACKUP SETUP DATA ERROR</b>	1. SETUP STORAGE DATA ERROR ( Rebooting the Machine. Then Clear error. CPU PCB needs to be changed if it occurs continuously.)
<b>E.24</b>	<b>BACKUP GAME DATA ERROR</b>	1. SETUP STORAGE DATA ERROR ( Rebooting the Machine. Then Clear error. CPU PCB needs to be changed if it occurs continuously.)
<b>TILT ERROR</b>	<b>DISPLAY BONUS FND</b>	It occurs machine was shaken. It automatically recovers after 15 seconds.

**\* HOW TO SET ID**

EACH P(PLAYER)HAS EACH OWN MAINBOARD.SO, THEY COMMUNICATETHROUGH ID OF THEIR OWN. MAKESURE TO SET DIP SWITCH AS SHOWN PHOTOS BELOW.

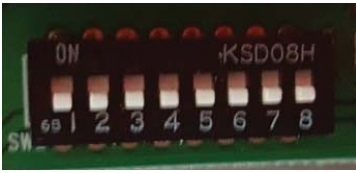
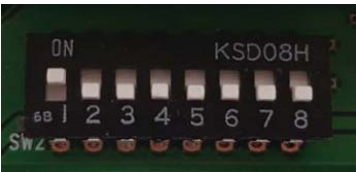
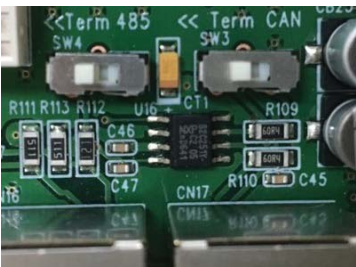
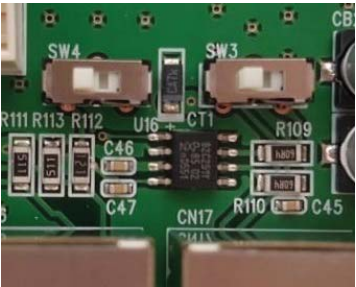
	<p>1P ID DIP SWITCH</p>
	<p>2P ID DIP SWITCH</p>
	<p>1P COMMUNICATION DIP SWITCH</p>
	<p>2P COMMUNICATION DIP SWITCH</p>

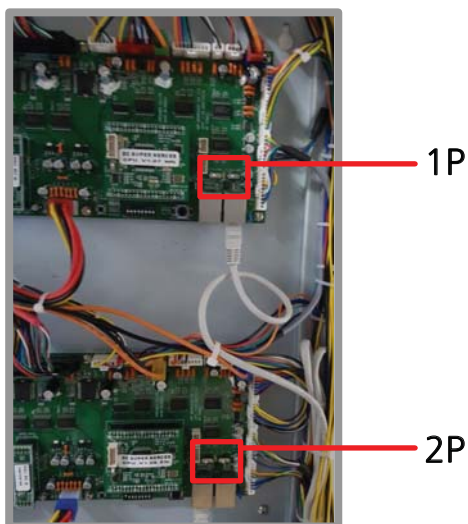

[ COMMUNICATION DIP SWITCH LOCATION ]

## 6. TROUBLESHOOTING

### 6-1. IN CASE OF POWER FAILURE

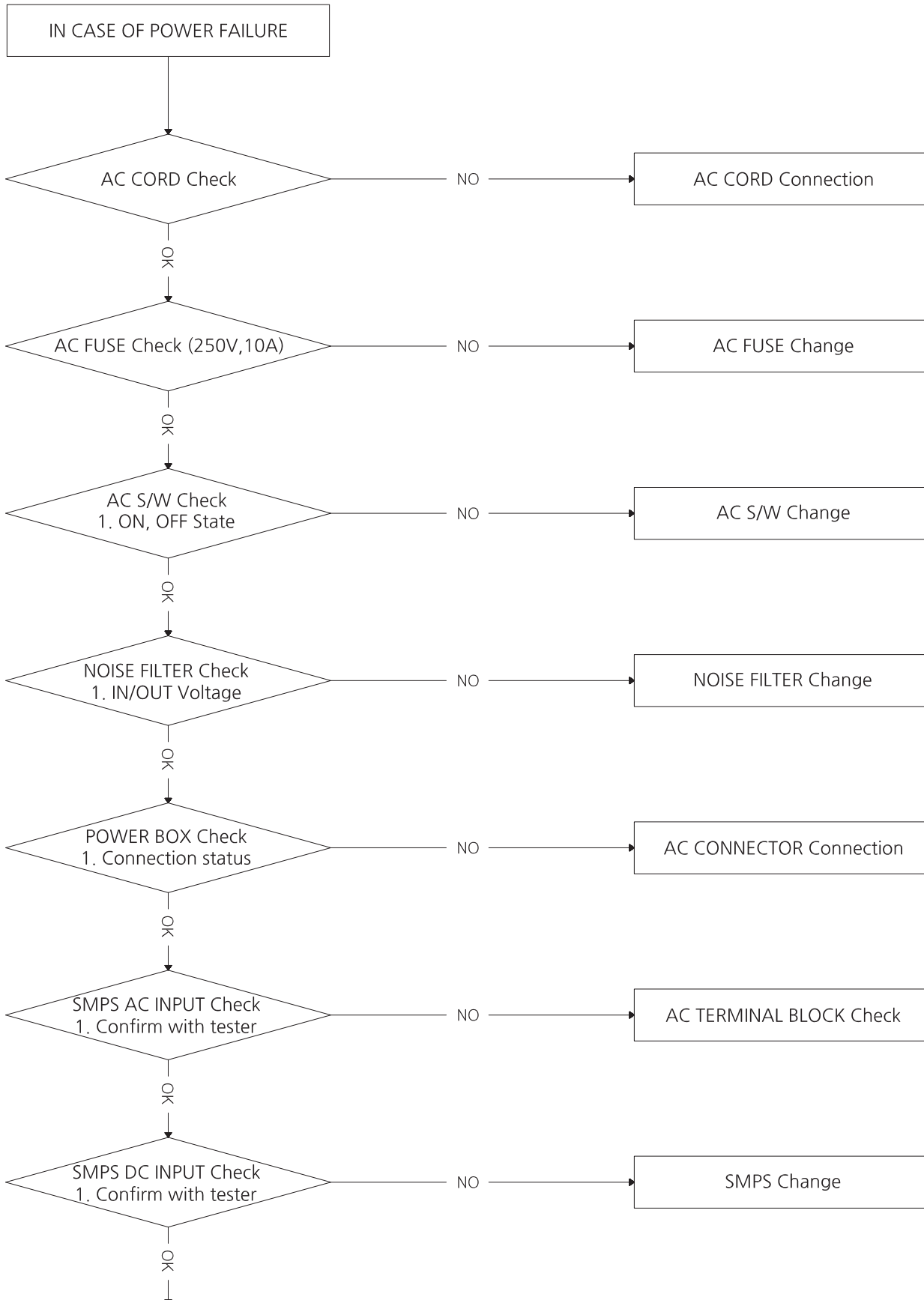

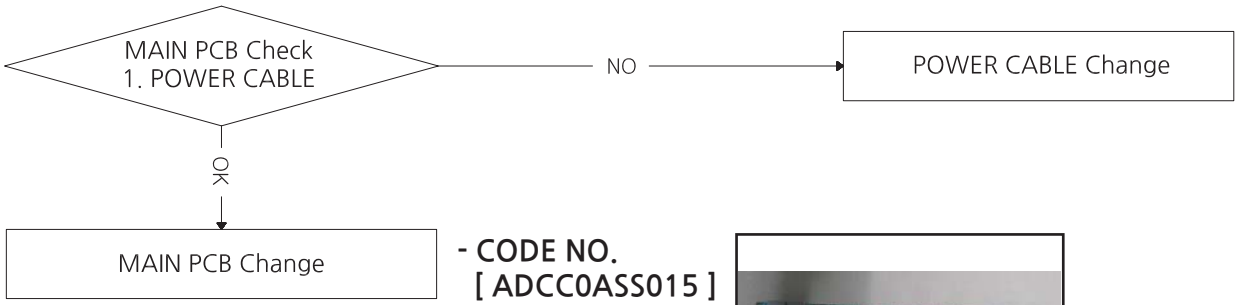

- CODE NO.  
[ ADCC0ASS015 ]





## 6-2. MEDAL CIRCULATION FND, CENTER FND PCB ERROR [1~2P]

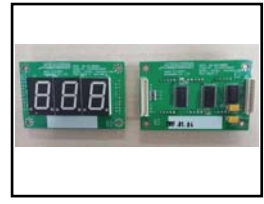
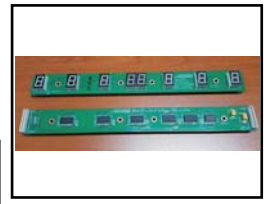
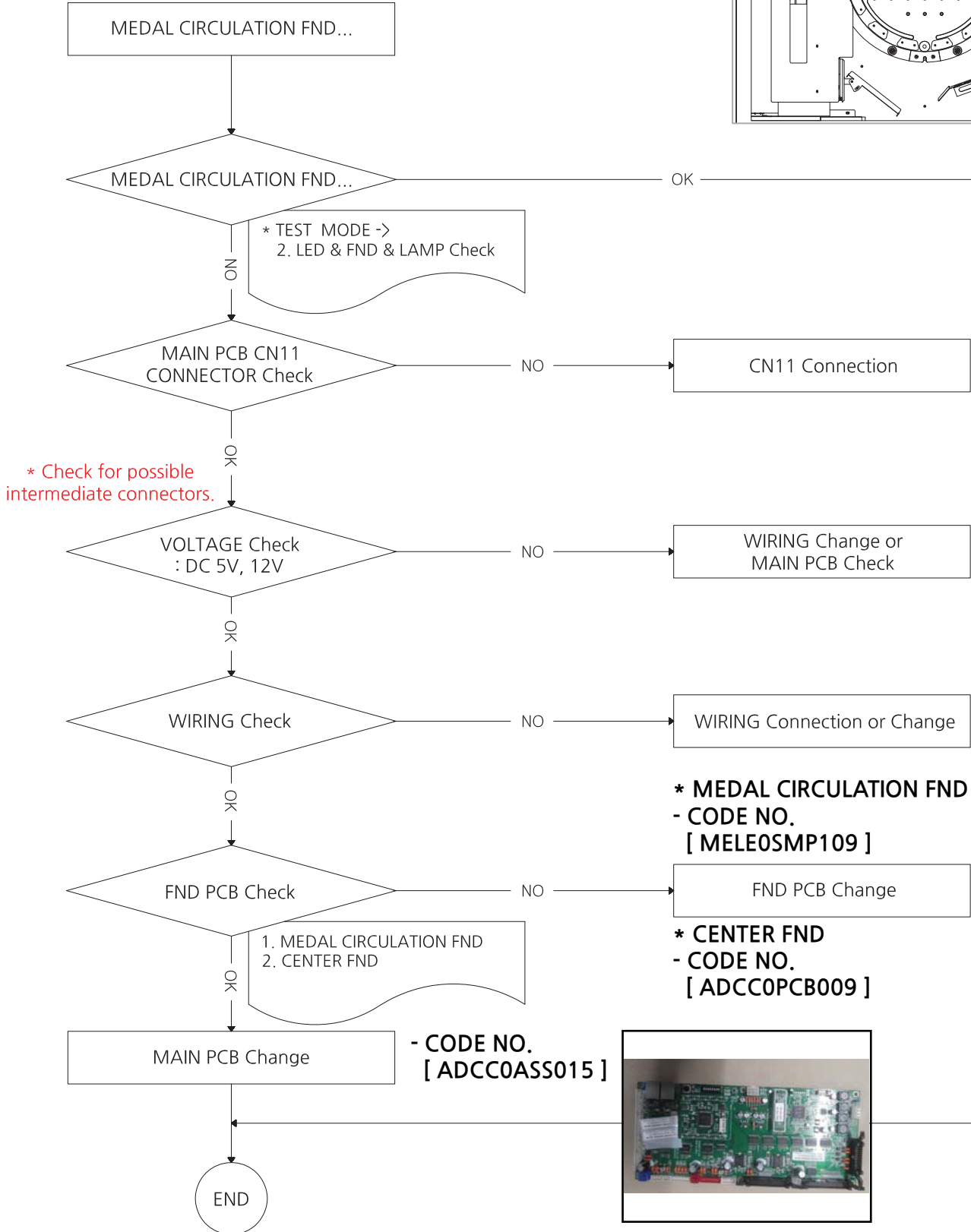
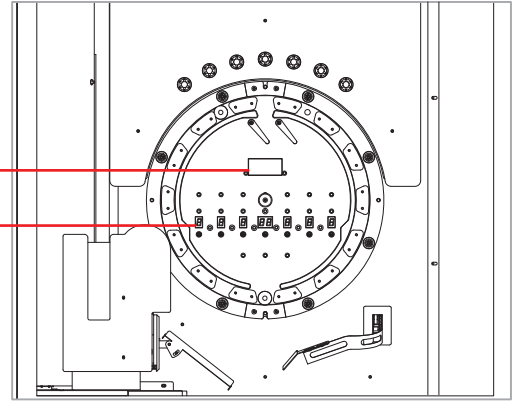

# 6-3. TICKETS, TOKENS, BONUS FND PCB ERROR [1~2P]

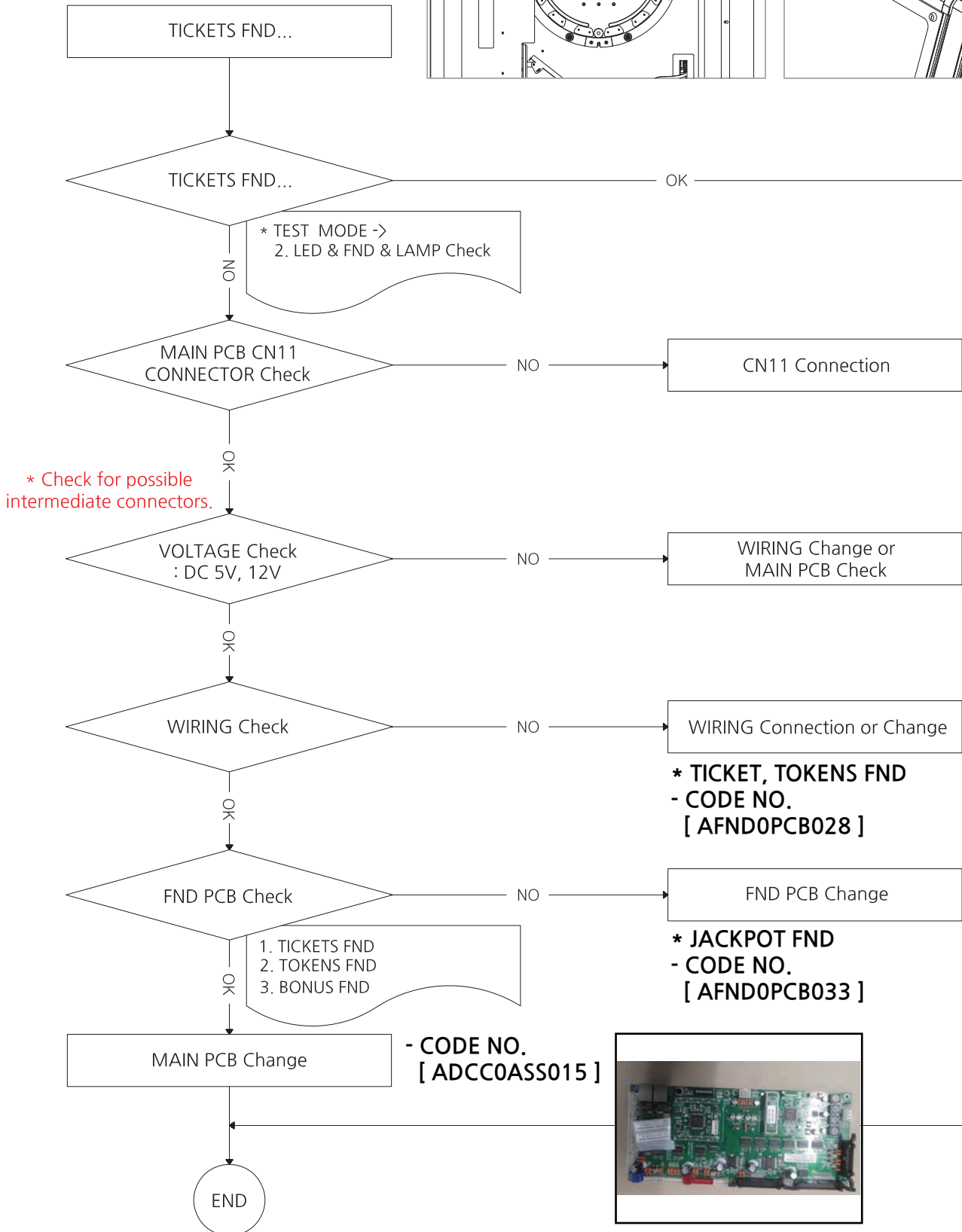
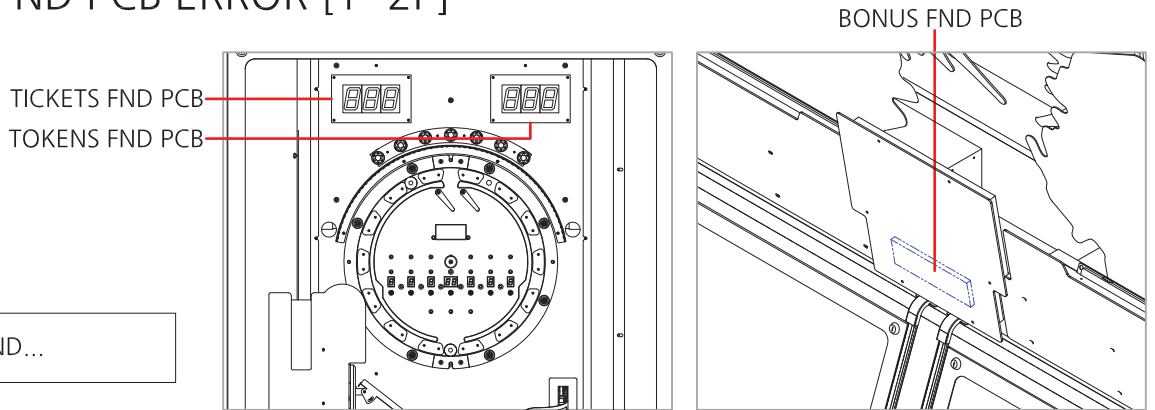

## 6-4. WHEEL SPIN LED PCB ERROR [1~2P]

WHEEL SPIN LED PCB

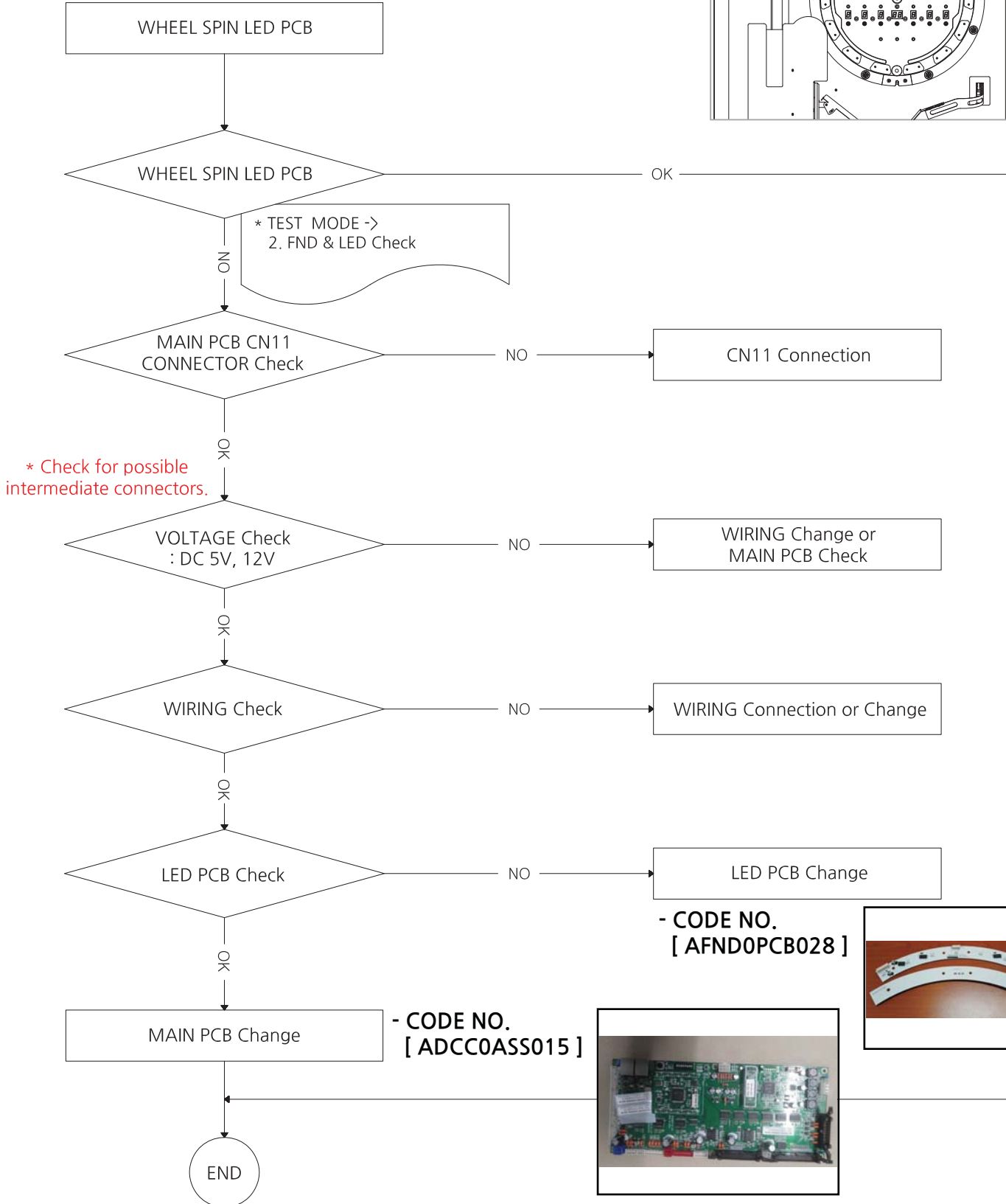
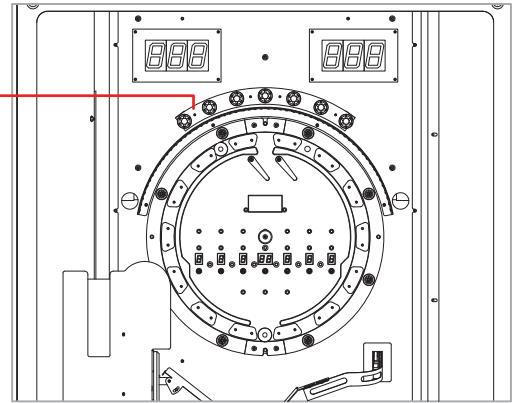

## 6-5. BUTTON LED PCB ERROR [1~2P]

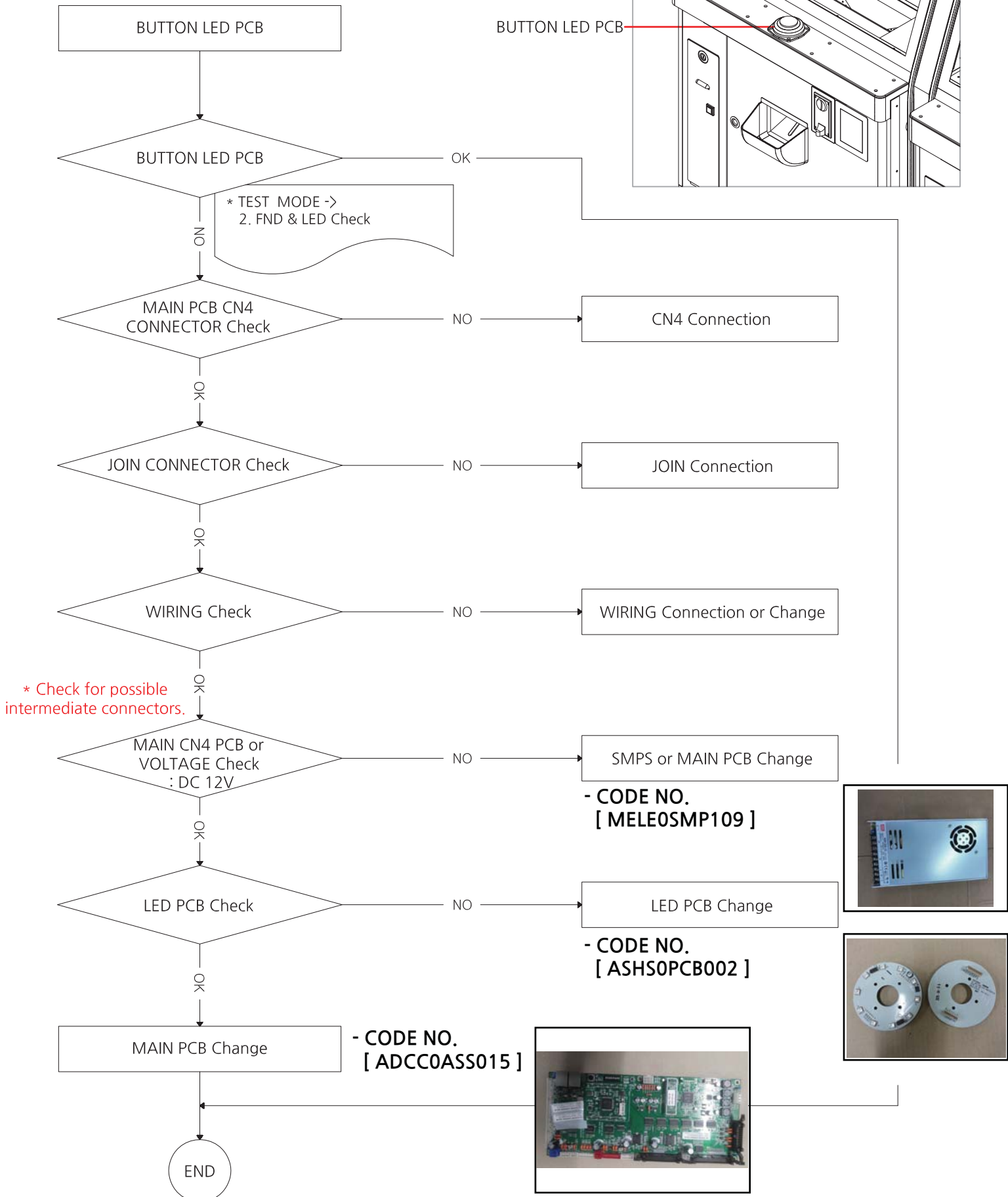

## 6-6. ARC FLEX LED, DOOR LED, TABLE LED, TOP LED ERROR [1~2P]

ARC FLEX LED

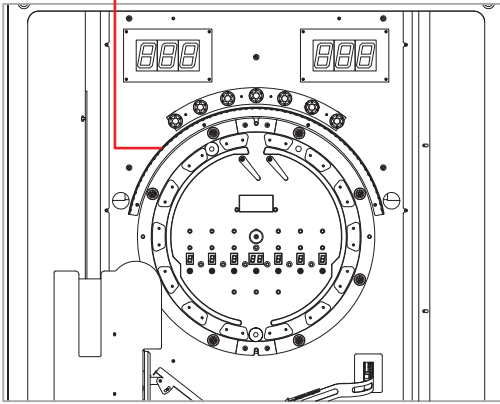
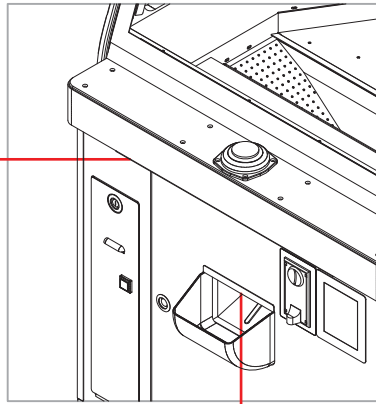
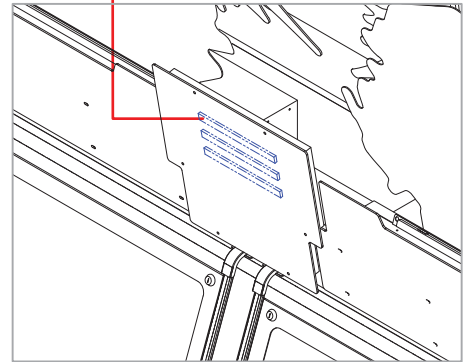

TABLE LED



TOP LED



DOOR LED

SPOT LED...

**\* DOOR LED**  
- CODE NO.  
[ AMUM0PCB005 ]

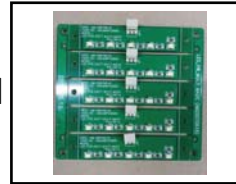

**\* TOP LED**  
- CODE NO.  
[ ADC20PCB001 ]

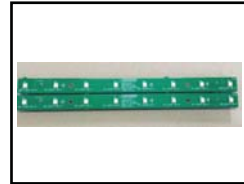

SPOT LED...

OK

\* TEST MODE ->  
2. FND & LED Check

NO

SMPS CONNECTION Check

NO

SMPS Connection

OK

JOIN CONNECTION Check

NO

JOIN Connection

OK

WIRING Check

NO

WIRING Connection or Change

OK

\* Check for possible  
intermediate connectors.

LED PCB VOLTAGE Check  
: DC 12V

NO

LED PCB Change

OK

\* Check for possible intermediate connectors.

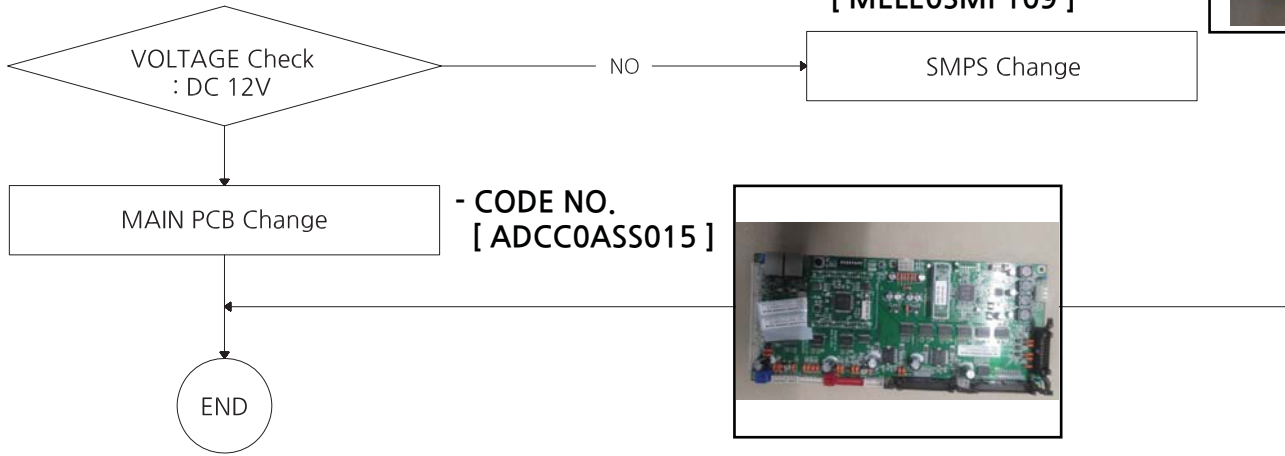

## 6-7. TICKET DISPENSER ERROR [1~2P]

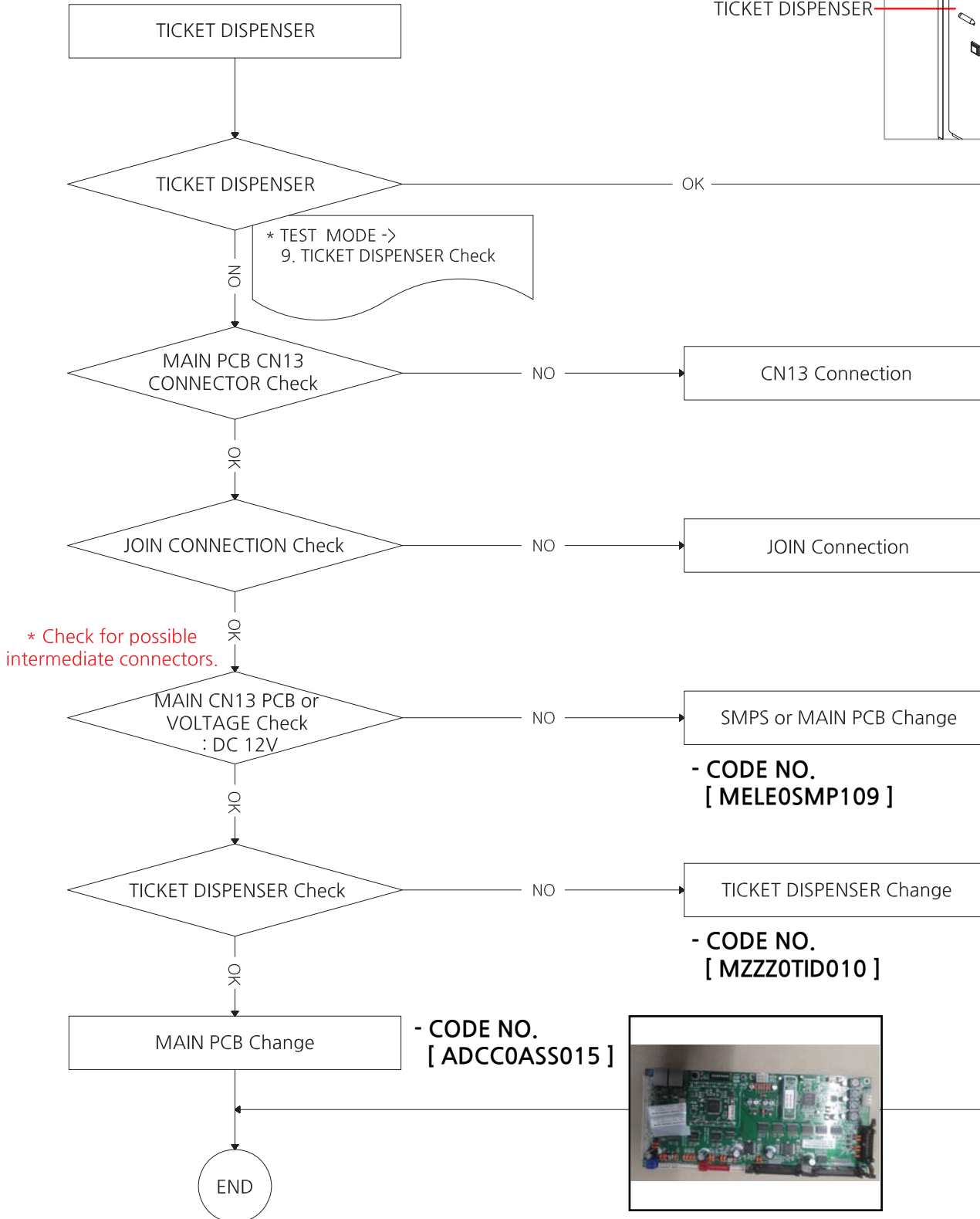
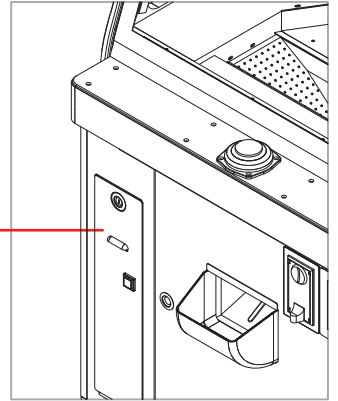

## 6-8. IN CASE OF MALFUNCTION OF PUSHER [1~2P] - ERROR 04

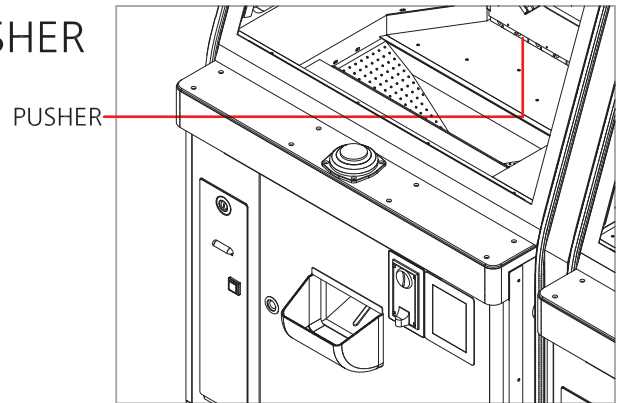

### \* CAUSE - COIN REMOVAL

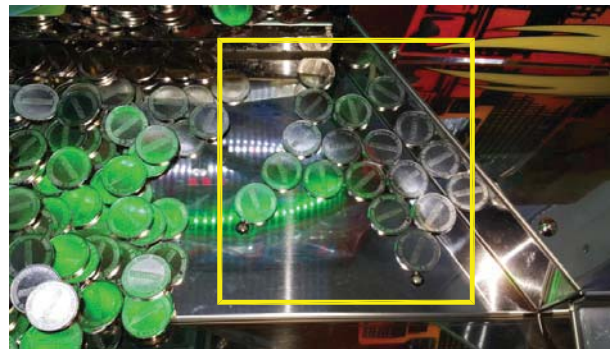

\* If the error can not be cleared by resetting, unfold a coin of the screw of the PUSHER Plate and press the reset button.



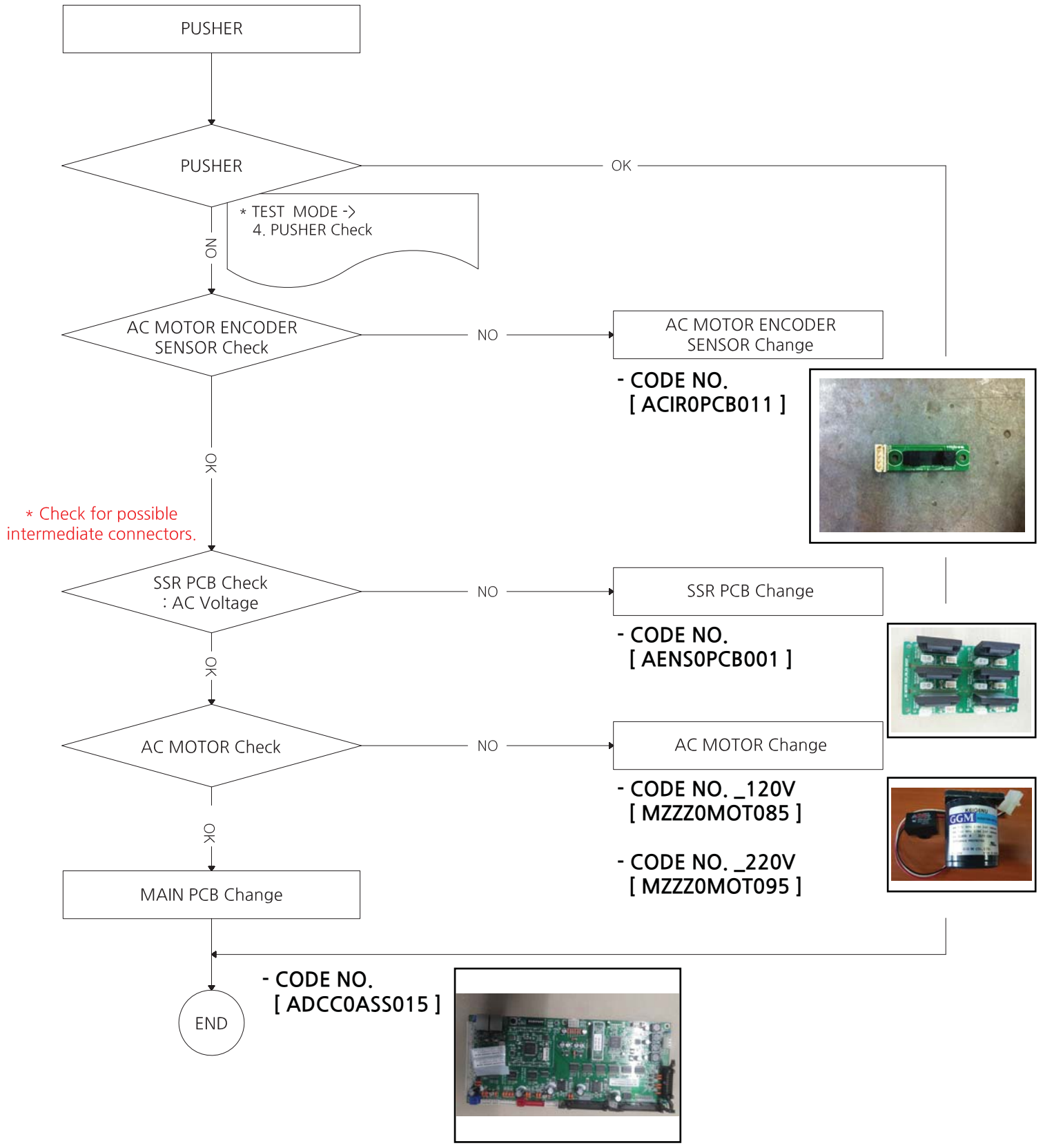

## 6-9. COUNTER HOPPER ERROR [1~2P] - ERROR 05

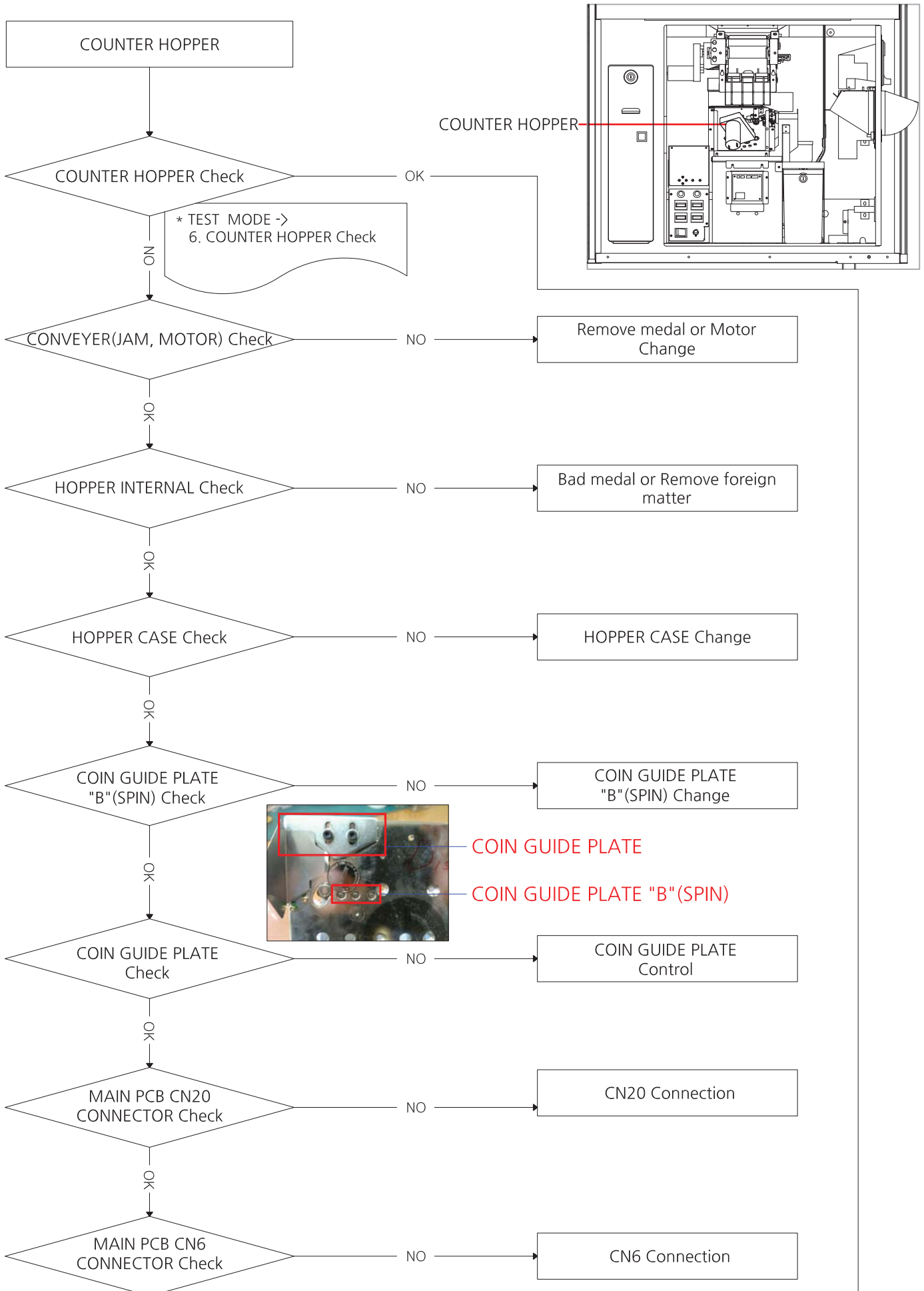



- CODE NO.  
[ MELE0SMP089 ]

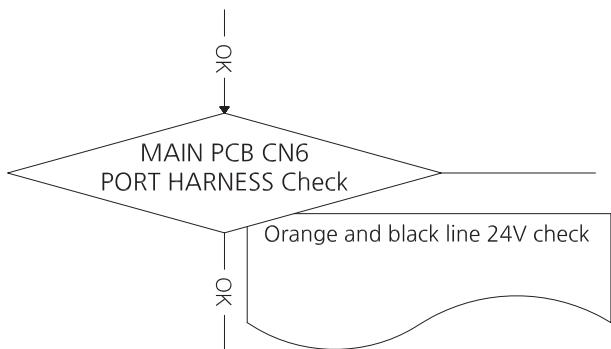

JOIN CONNECTOR CHECK and  
24V SMPS Change



- CODE NO.  
[ ADCC0ASS015 ]

MAIN PCB Change

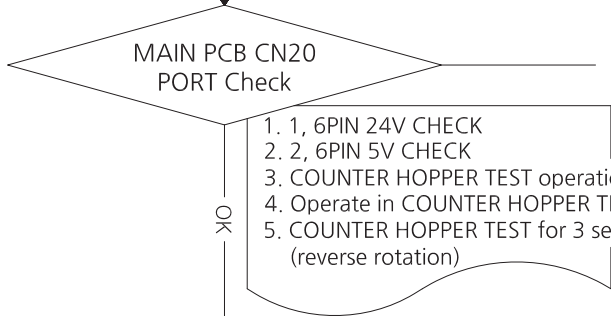

JOIN CONNECTOR Connection

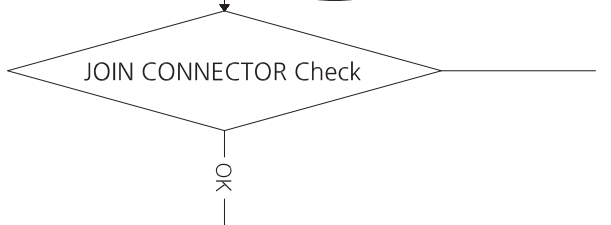

JP1, JP2, JP3 Connection

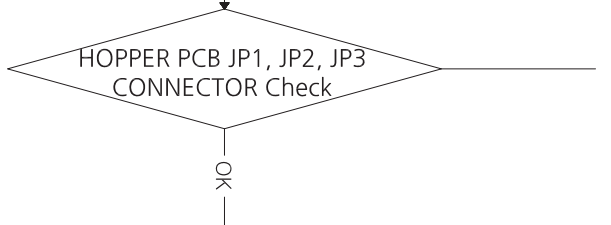

- CODE NO.  
[ AZZZ0PCB172 ]

HOPPER PCB Change

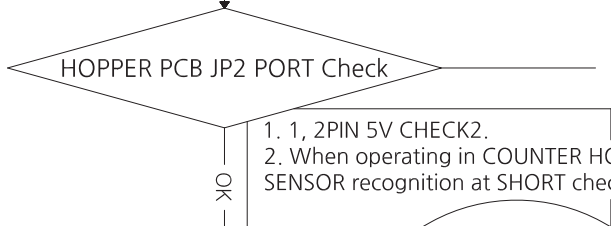

- CODE NO.  
[ AZZZ0PCB172 ]

HOPPER PCB Change

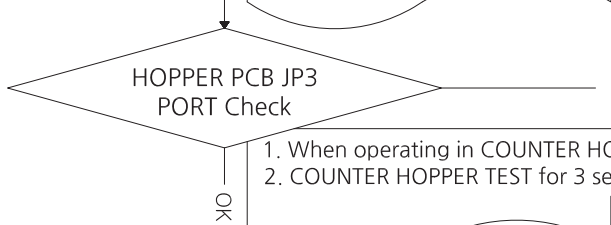

HOPPER MOTOR CONNECTION

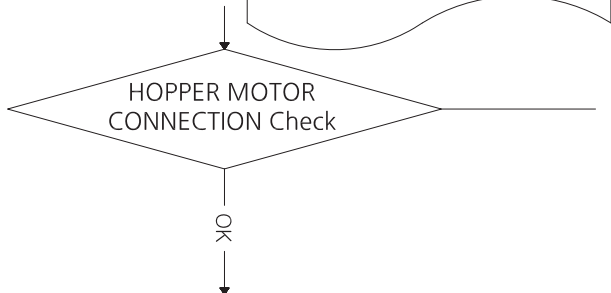

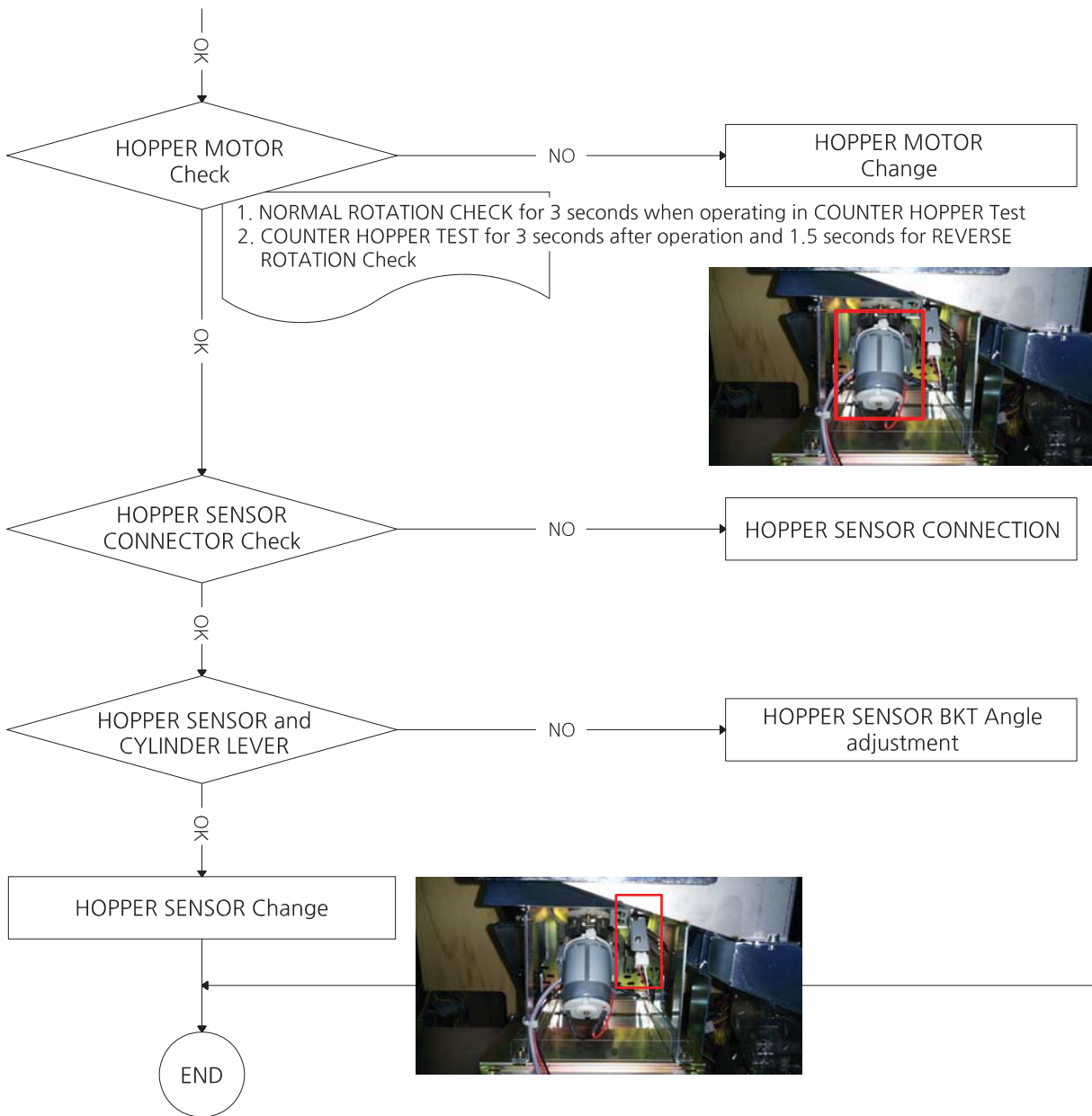

## 6-10. ELEVATOR HOPPER ERROR [1~2P] - ERROR 06

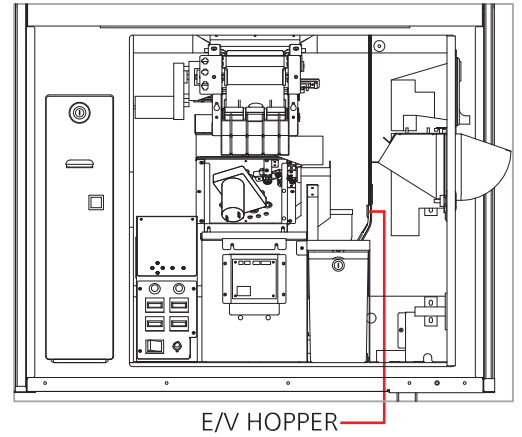

\* CAUSE - LACK OF COIN or COIN JAM

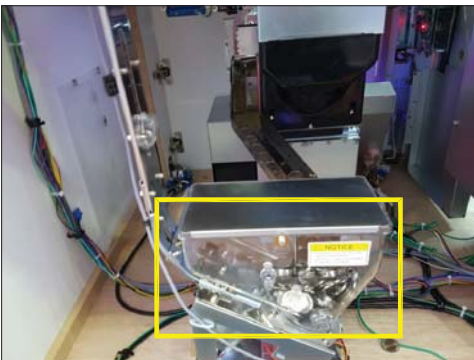

\* CAUSE - ELEVATOR RAIL COIN JAM

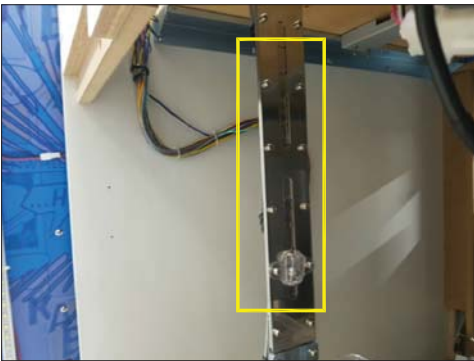

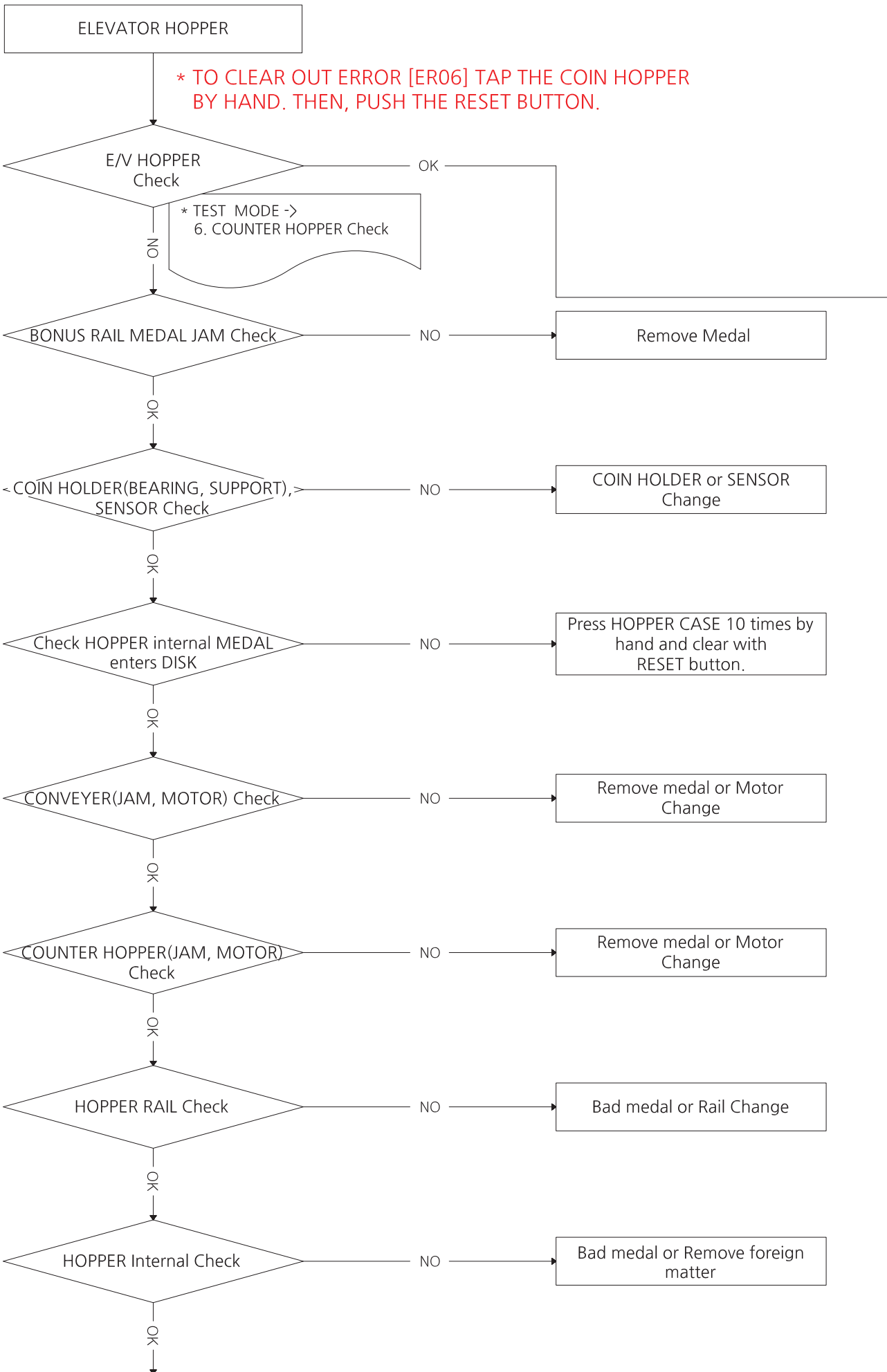

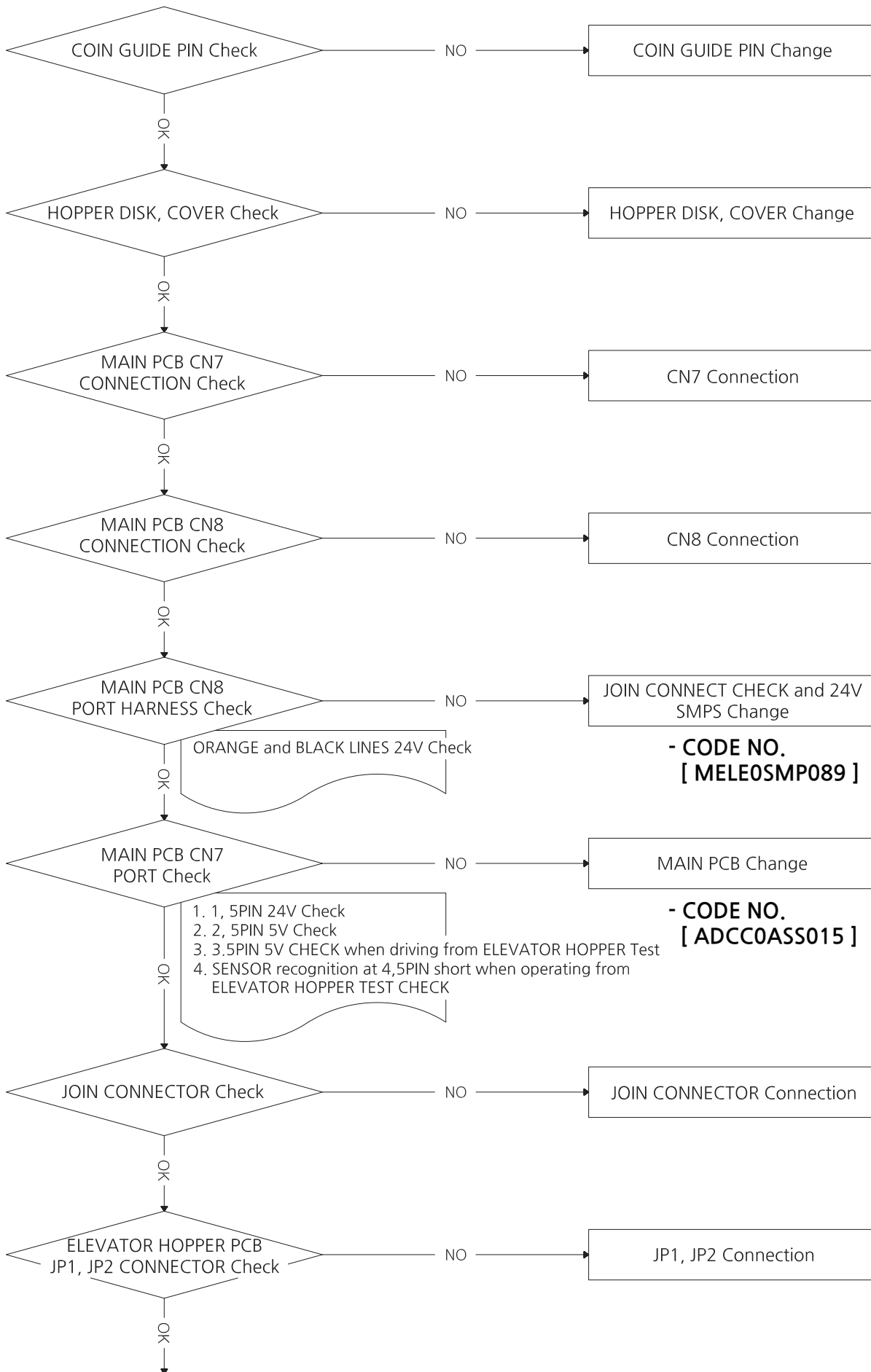

ORANGE and BLACK LINES 24V Check

JOIN CONNECT CHECK and 24V SMPS Change

**- CODE NO. [ MELE0SMP089 ]**

MAIN PCB Change

**- CODE NO. [ ADCC0ASS015 ]**

1. 1, 5PIN 24V Check
2. 2, 5PIN 5V Check
3. 3, 5PIN 5V CHECK when driving from ELEVATOR HOPPER Test
4. SENSOR recognition at 4,5PIN short when operating from ELEVATOR HOPPER TEST CHECK

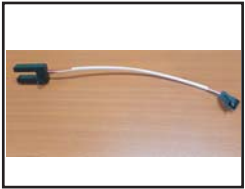

- CODE NO.  
[ AZZZ0PCB173 ]

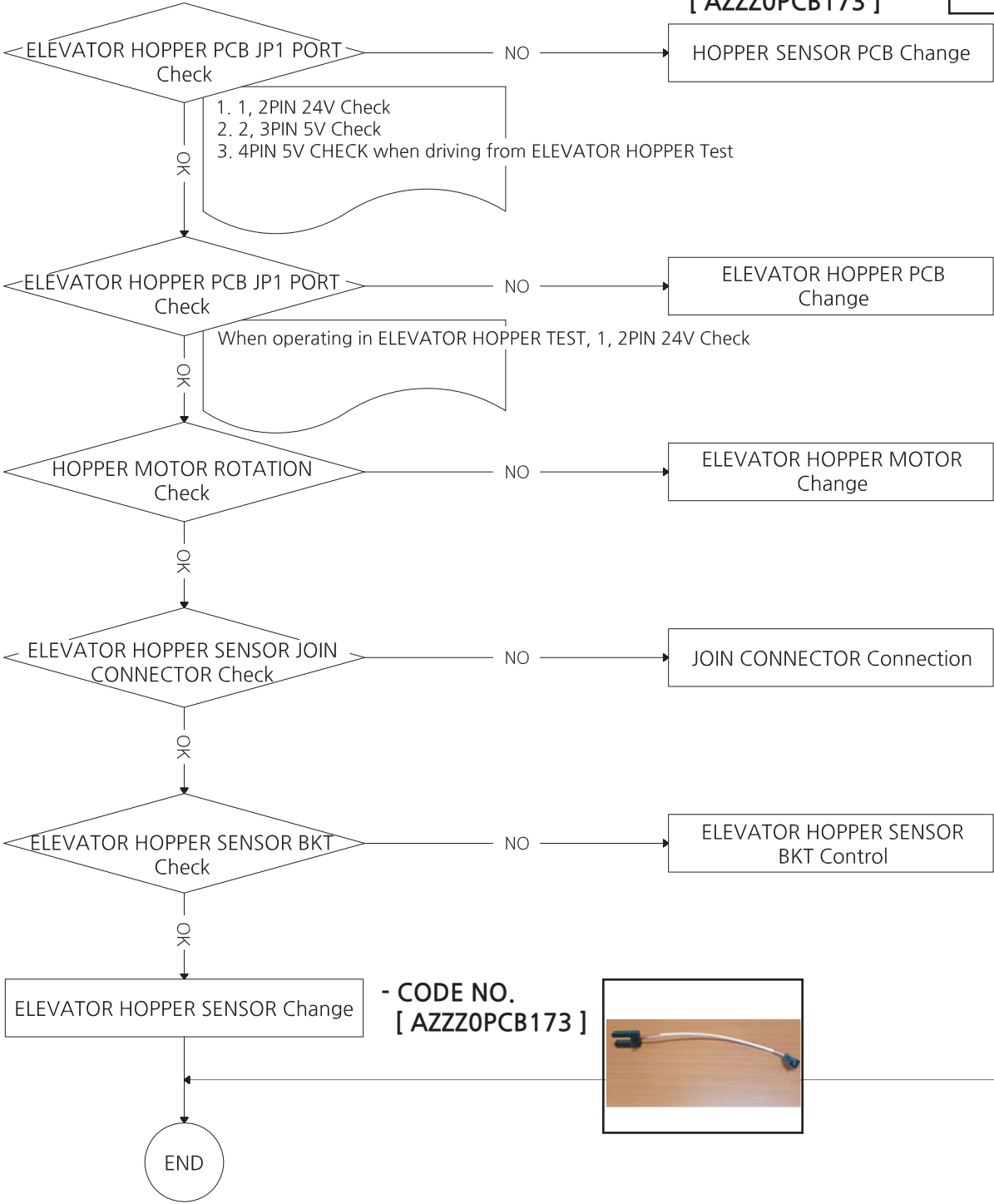

- CODE NO.  
[ AZZZ0PCB173 ]





## 6-11. CIRCULATION WIPER ERROR [1~2P] - ERROR 07

\* CAUSE - CIRCULATION WIPER MOTOR

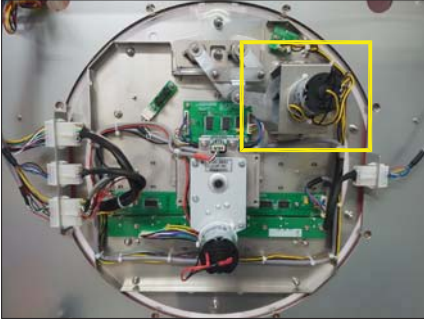

CIRCULATION WIPER

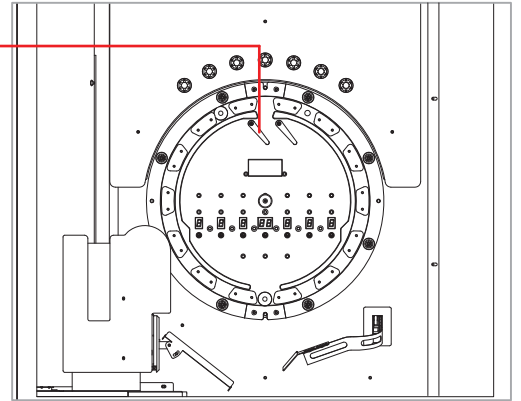

\* CAUSE - CIRCULATION WIPER SNEOSR

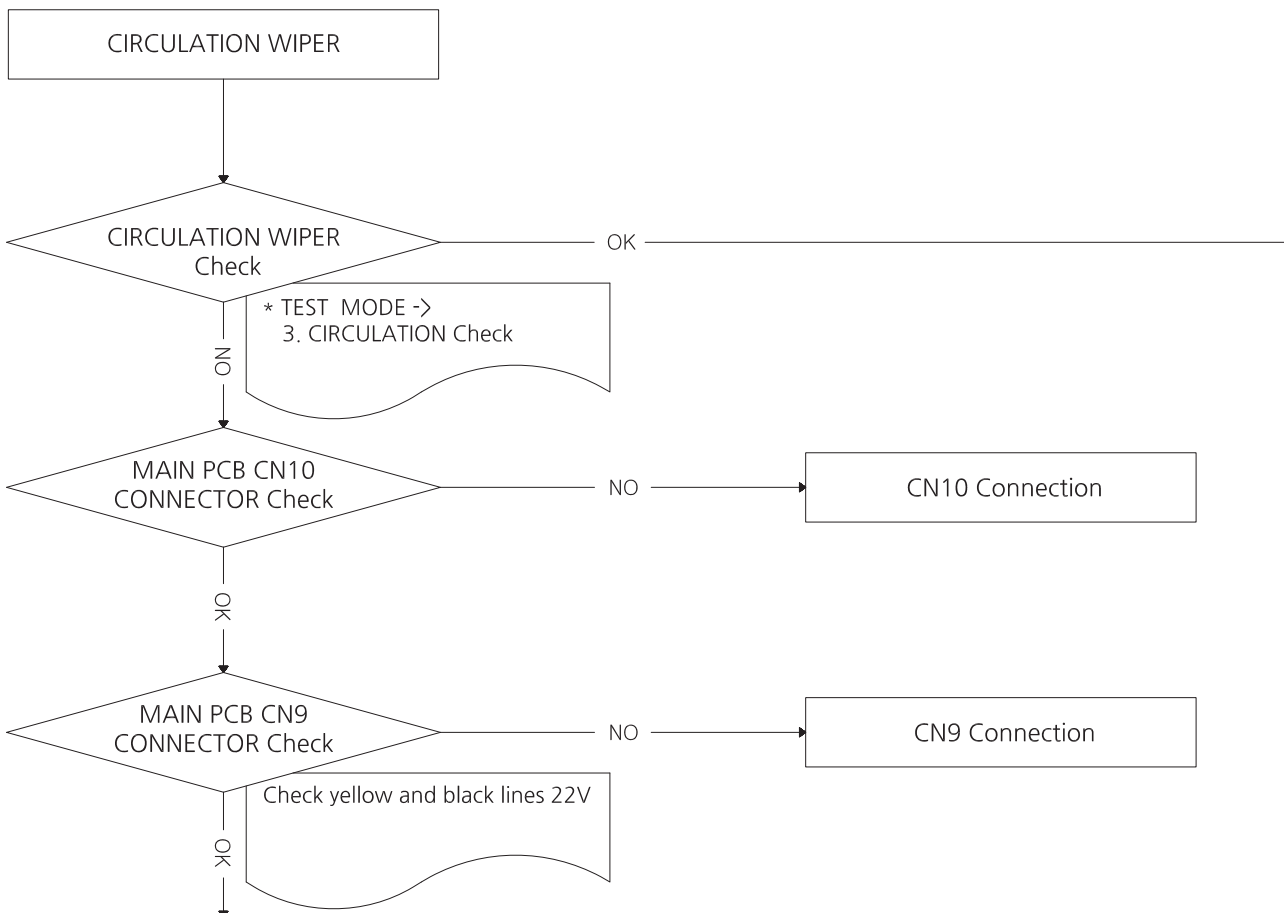
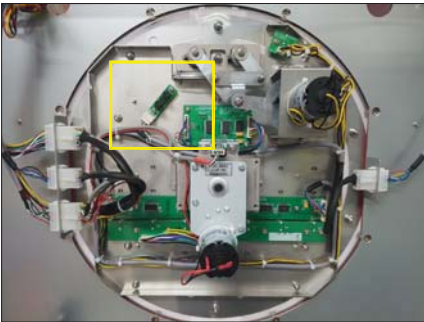



- CODE NO.  
[ MELE0SMP089 ]

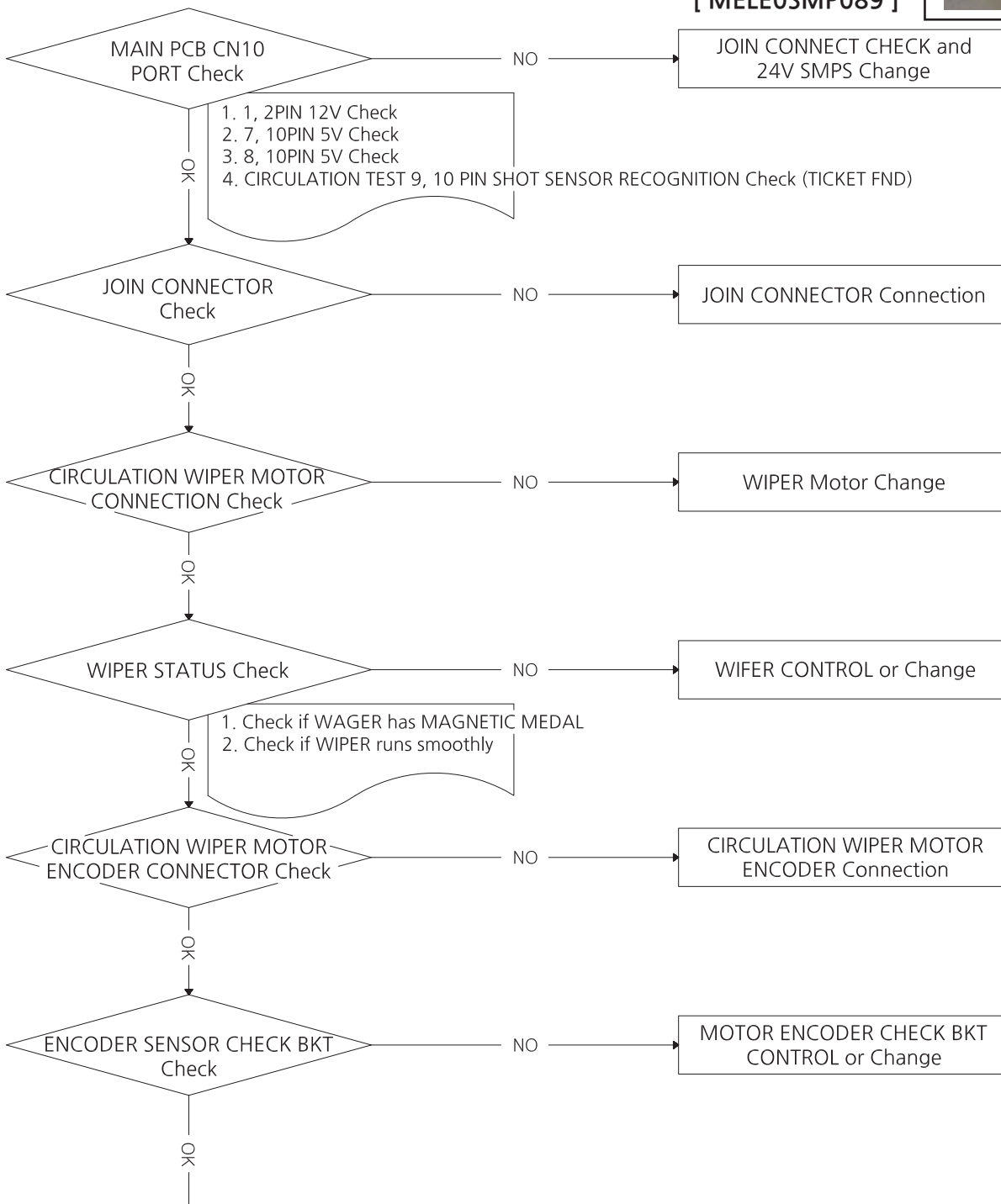

- CODE NO.  
[ AZZZ0PCB103 ]

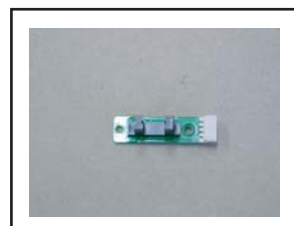

END

## 6-12. CIRCULATION ENCODER SENSOR ERROR [1~2P] - ERROR 09

\* CAUSE - COIN JAM

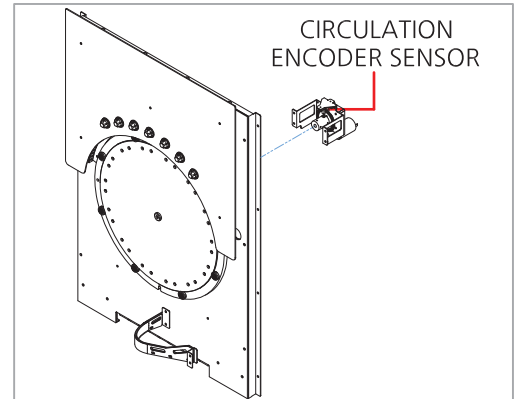

\* CAUSE - CIRCULATION MOTOR

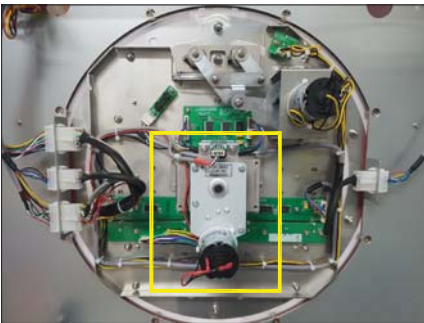

\* CAUSE - CIRCULATION SENSOR

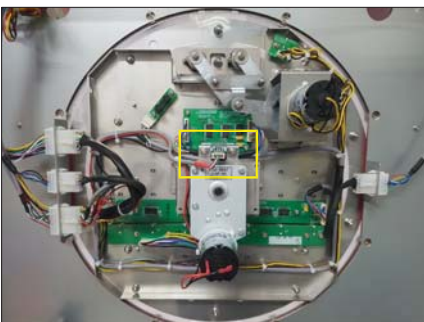

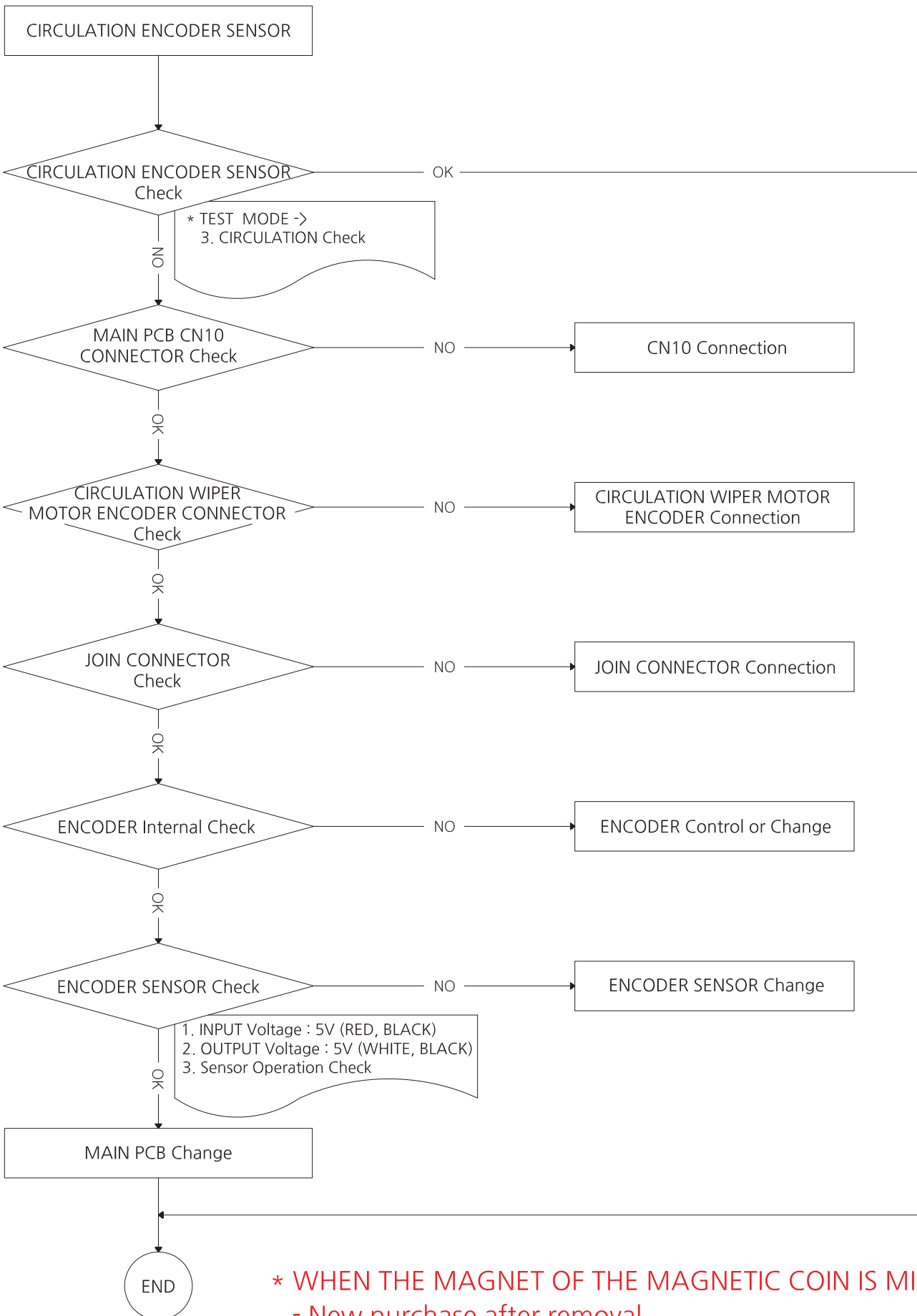

\* WHEN THE MAGNET OF THE MAGNETIC COIN IS MISSING  
- New purchase after removal

## 6-13. CIRCULATION MAGNETIC SENSOR PCB ERROR [1~2P] - ERROR 10 (MEDAL CIRCULATION CHECK-A PCB ASS'Y)

\* CAUSE - MAGNETIC SENSOR PCB

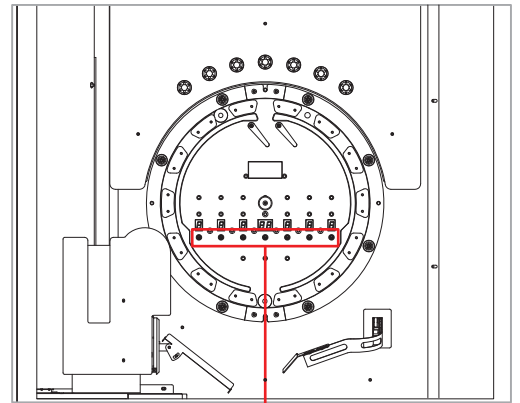
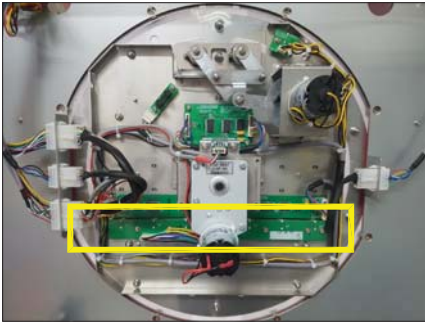

CIRCULATION MEDAL CHECK AREA [A]

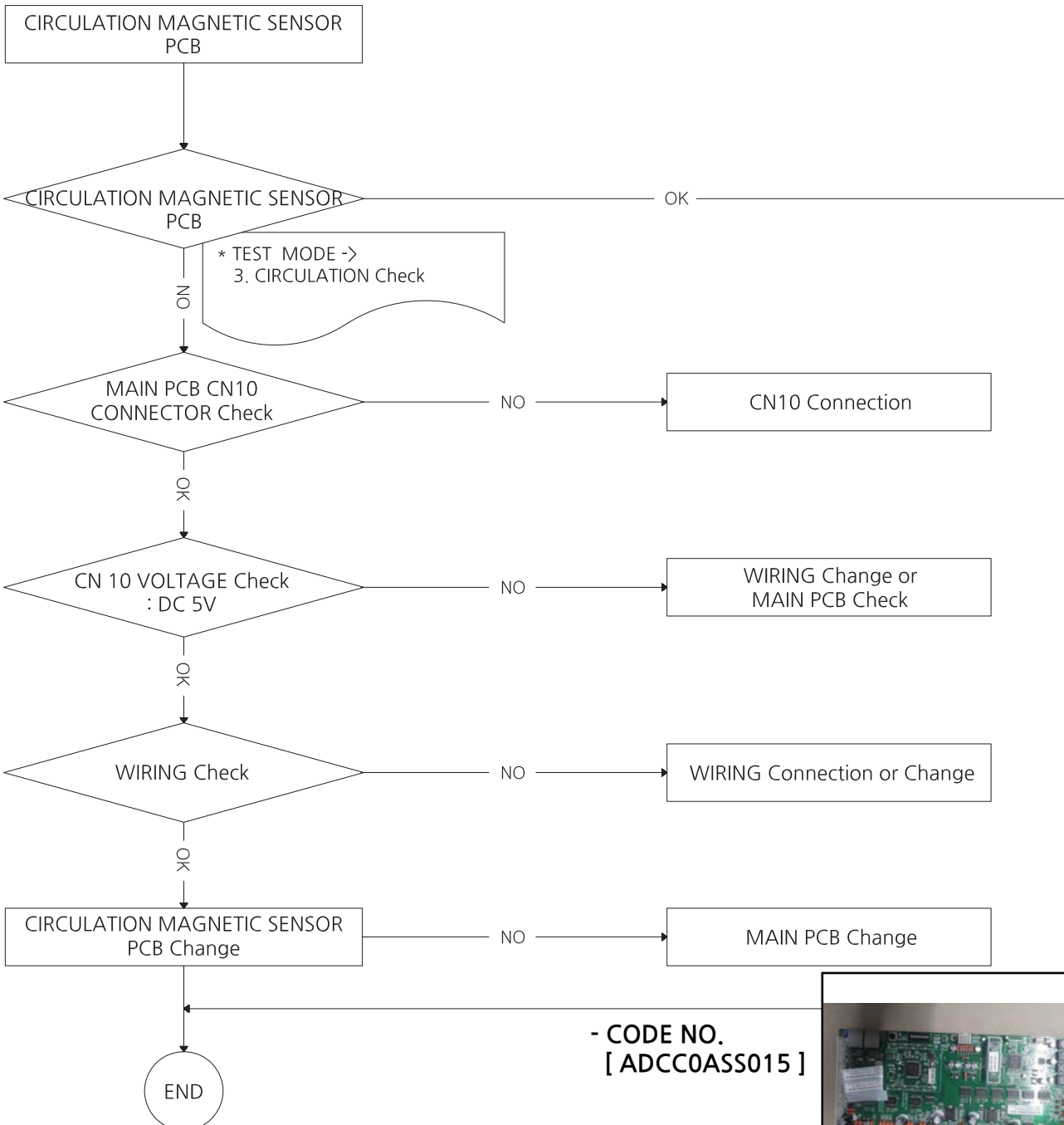

- CODE NO. [ADCC0ASS015]



## 6-14. CIRCULATION ERROR [1~2P] - ERROR 03

(MEDAL CIRCULATION CHECK-B PCB ASS'Y)

CIRCULATION MEDAL CHECK AREA [B]

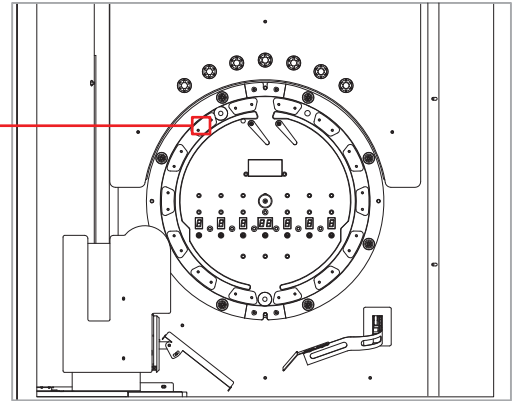

\* CAUSE - MEDAL 8ea JAM



- Disable using magnet
- Tap and release
- Move down

\* CAUSE - CIRCULATION SENSOR



\* IF THE COIN IS PARTIALLY CAUGHT  
- Remove the RING GUIDE by tapping it after removing it

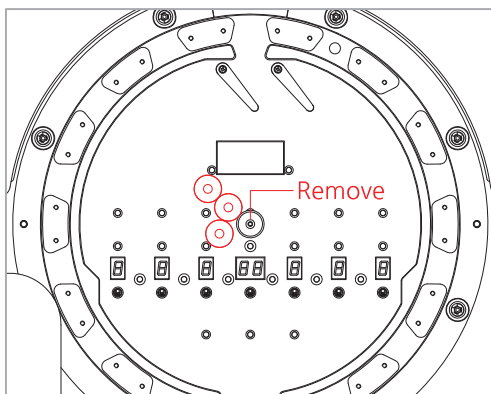

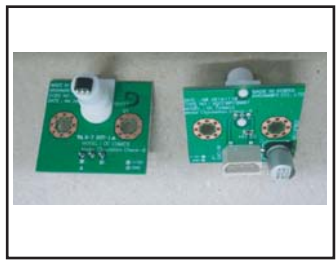
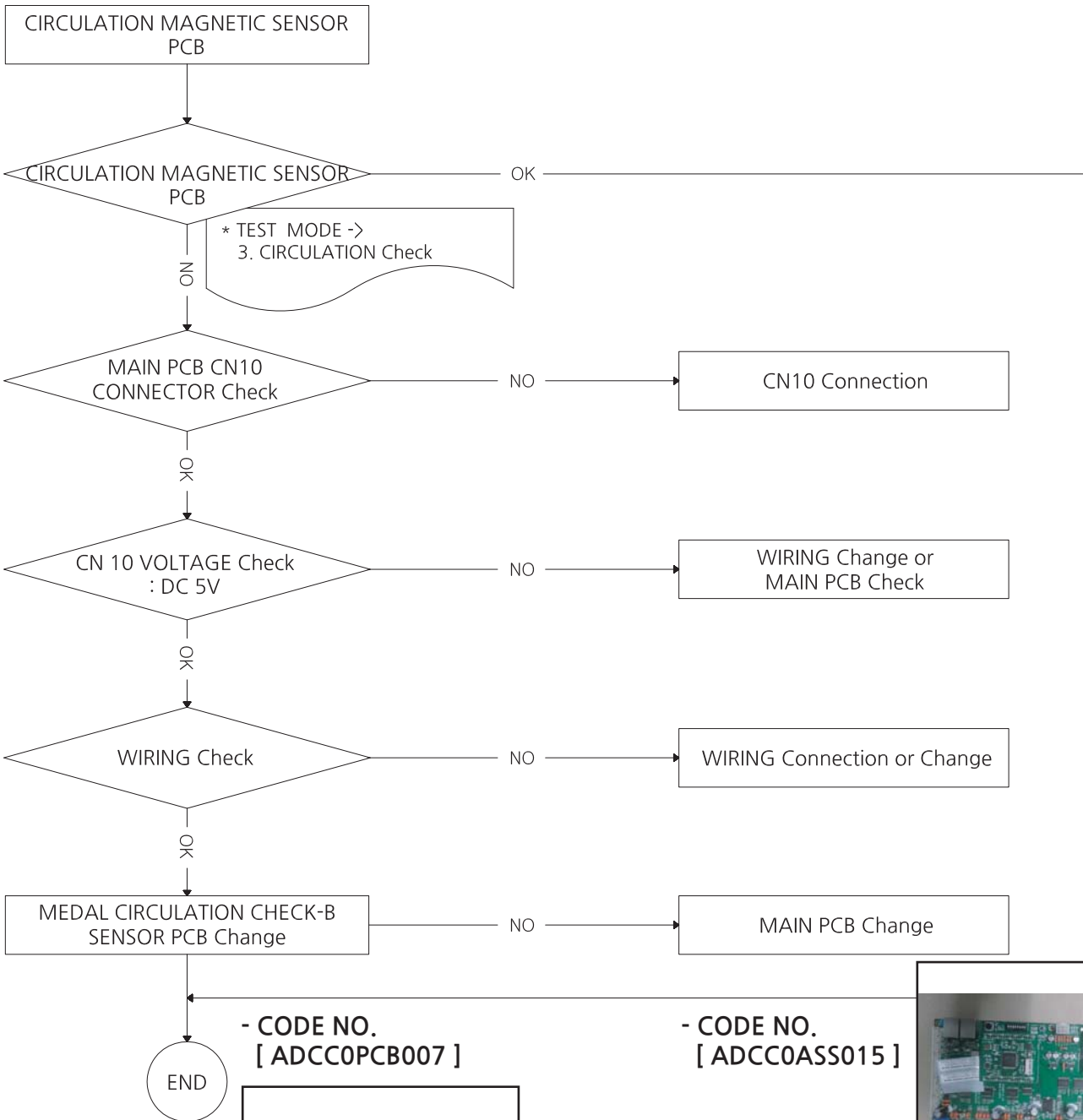

- CODE NO. [ ADCC0ASS015 ]



## 6-15. CONVEYER ERROR [1~2P] - ERROR 08

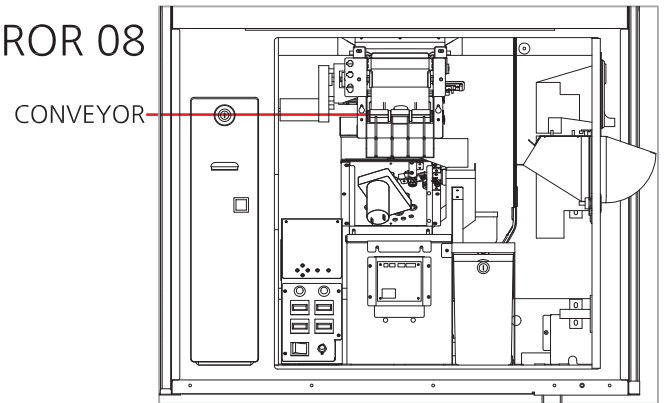

### \* CAUSE - COIN JAM



### \* CAUSE - CONVEYER MOTOR

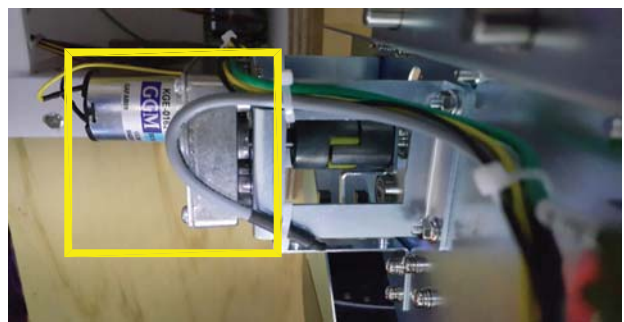

### \* CAUSE - CONVEYER BELT

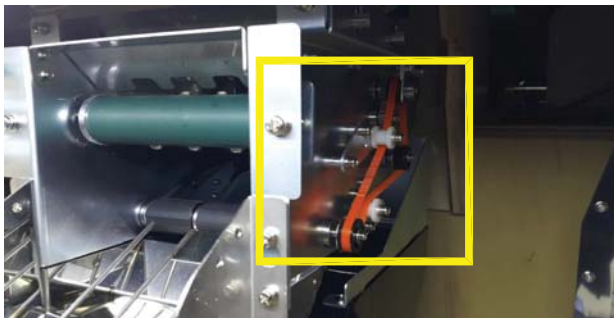

### \* CAUSE - CONVEYER SENSOR

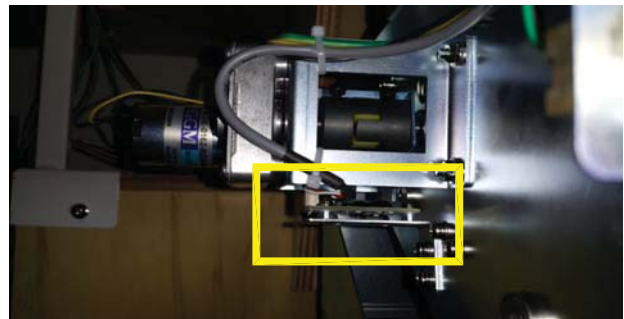

### \* HOW TO DISASSEMBLE CONVEYOR

- ① Removing screw 2EA
  - ② Separation of wiring 3EA
  - ③ Pull out the conveyor from the side 4EA shaft
  - ④ Assemble hinge to top of PAYOUT PANEL when reassembling.
- Reassemble them in reverse order

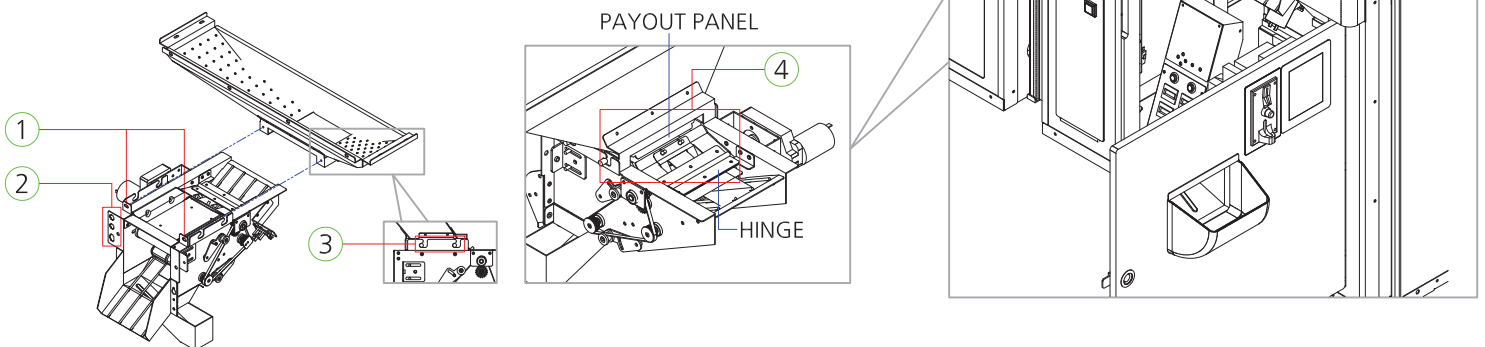



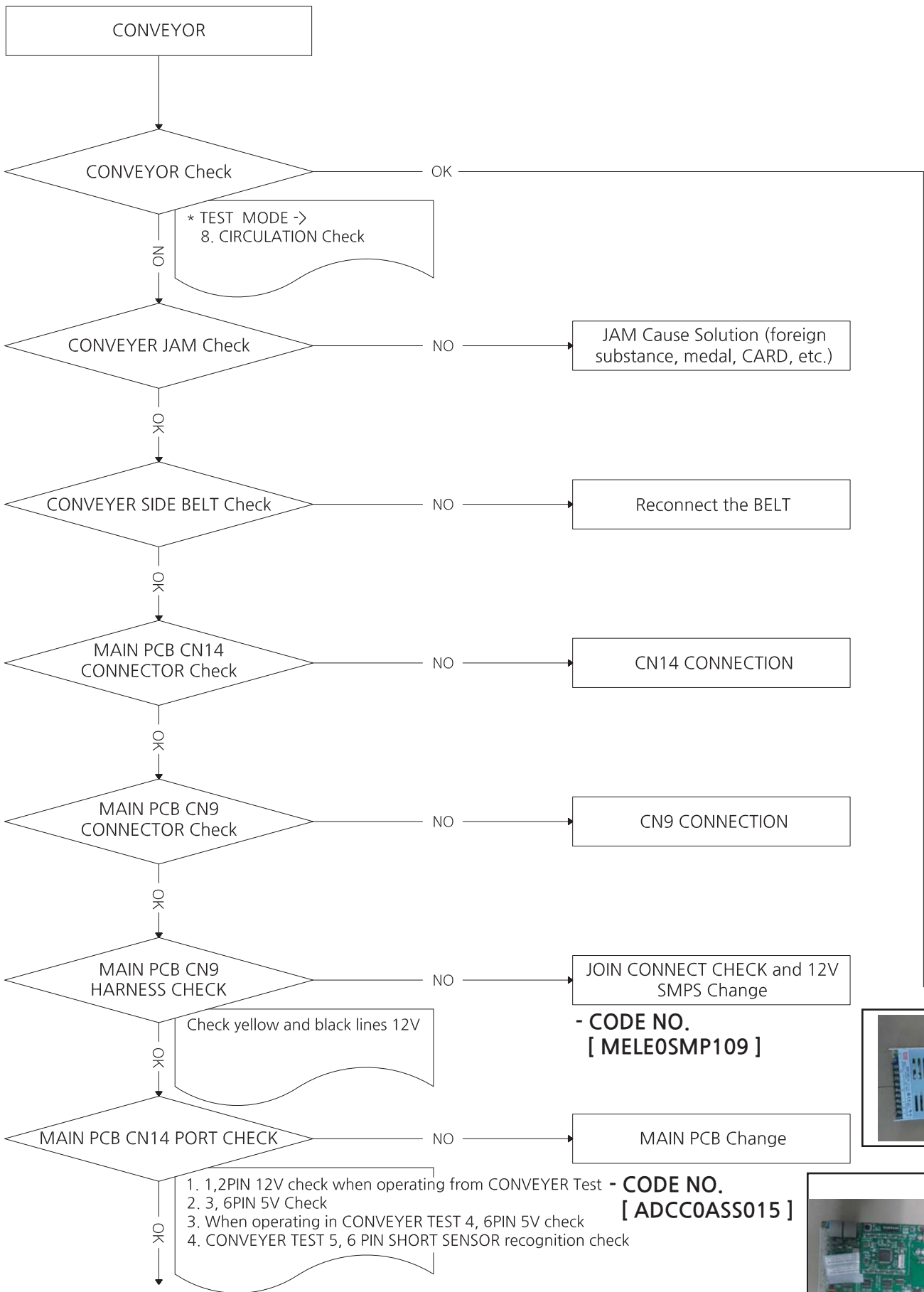

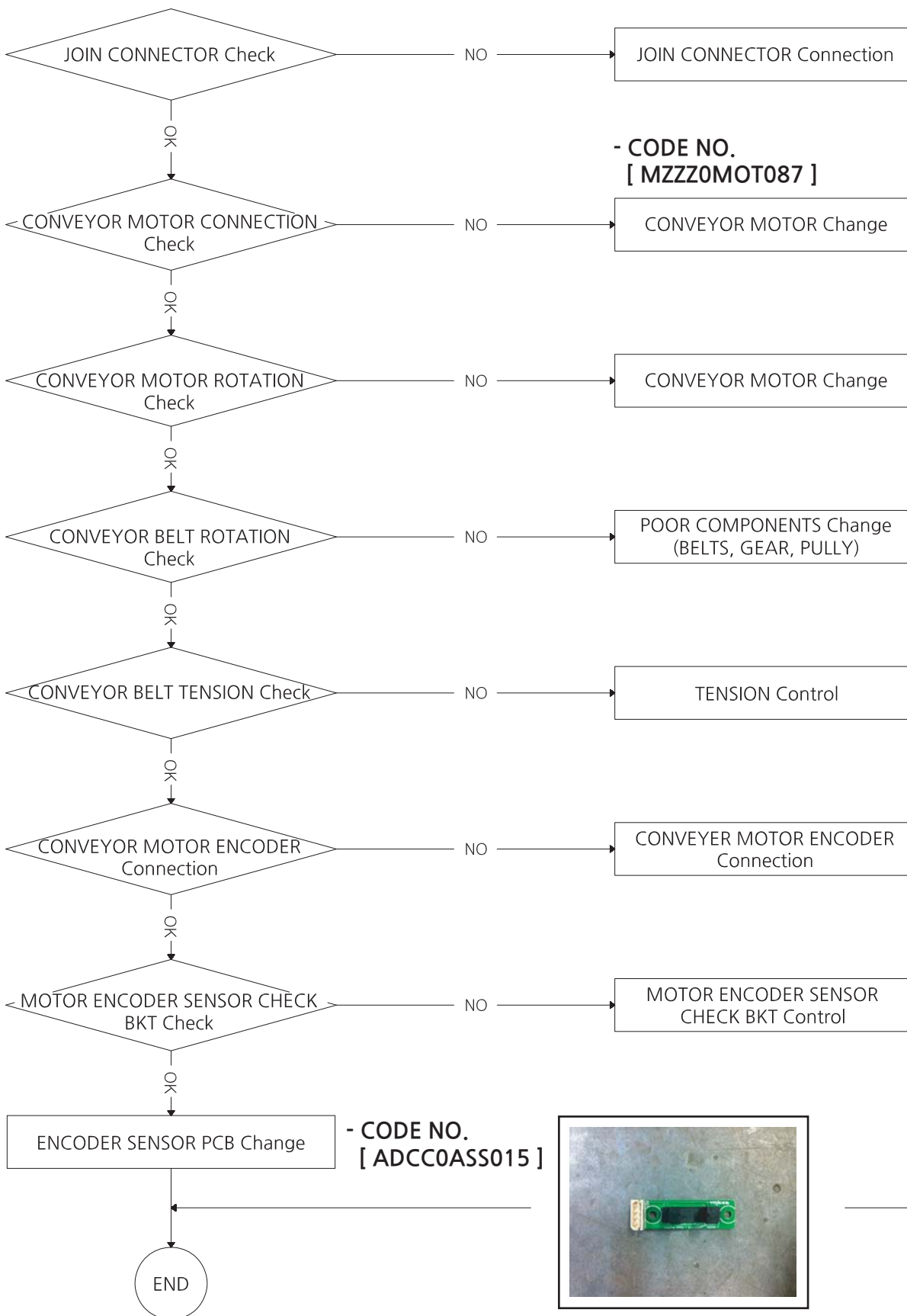

- CODE NO.  
[ MZZZ0MOT087 ]



- CODE NO.  
[ ADCC0ASS015 ]



# 6-16. CARD DISPENSER ERROR [1~2P] - ERROR 11

\* CAUSE - CARD JAM or EMPTY

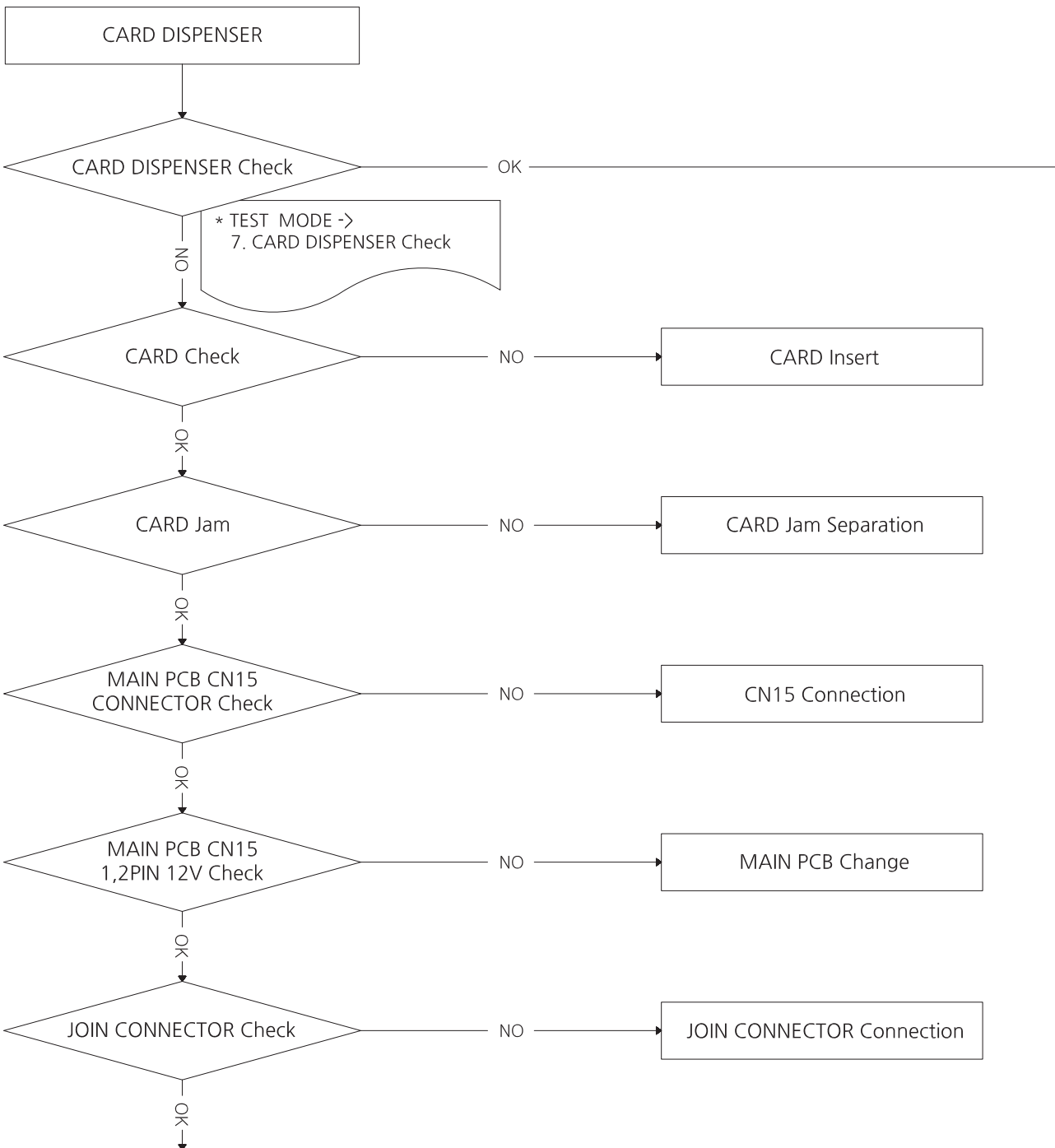
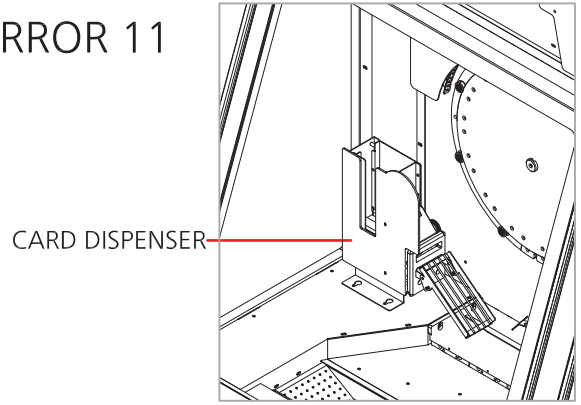

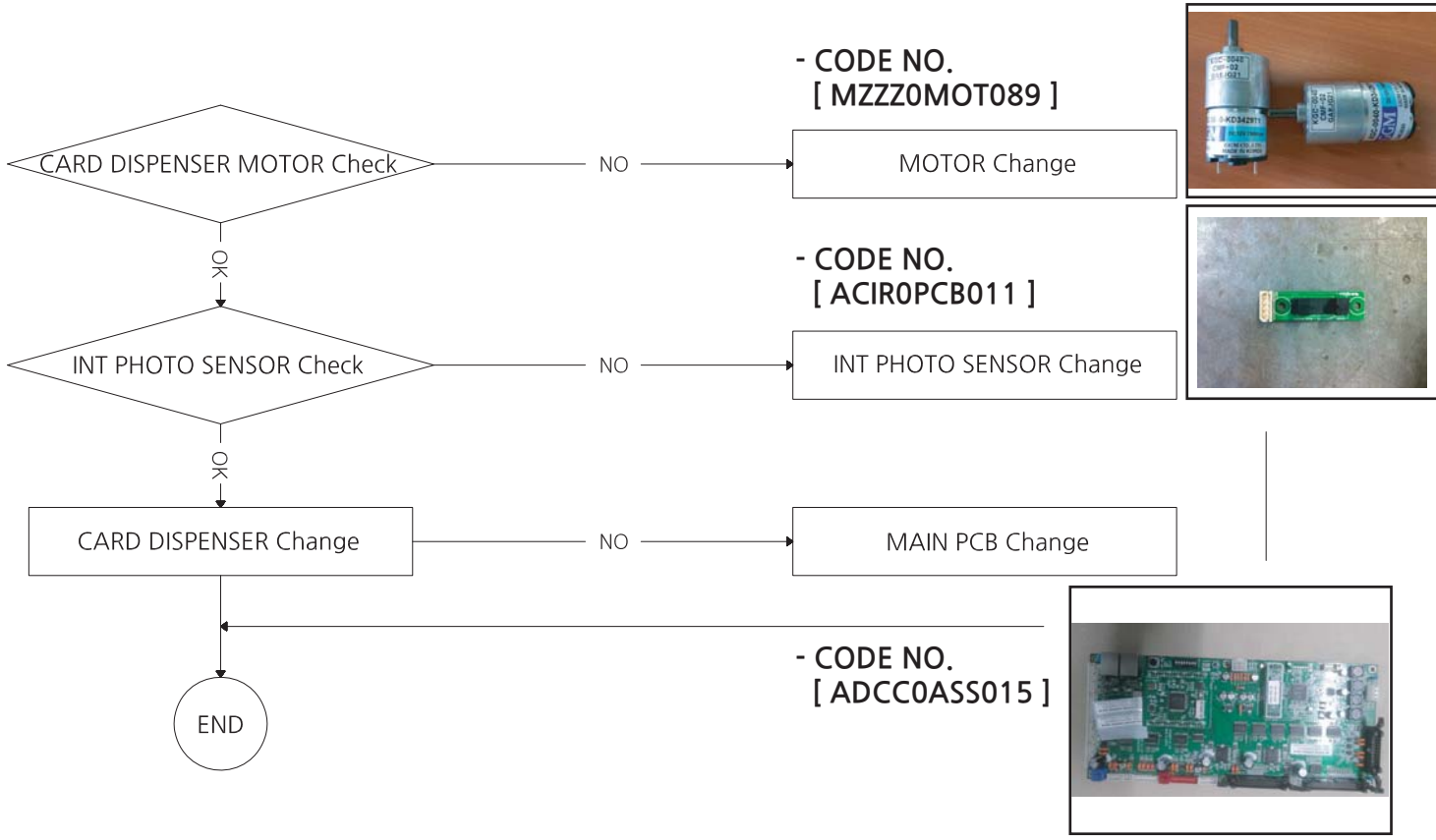

## 6-17. SOUND ERROR [1~2P]

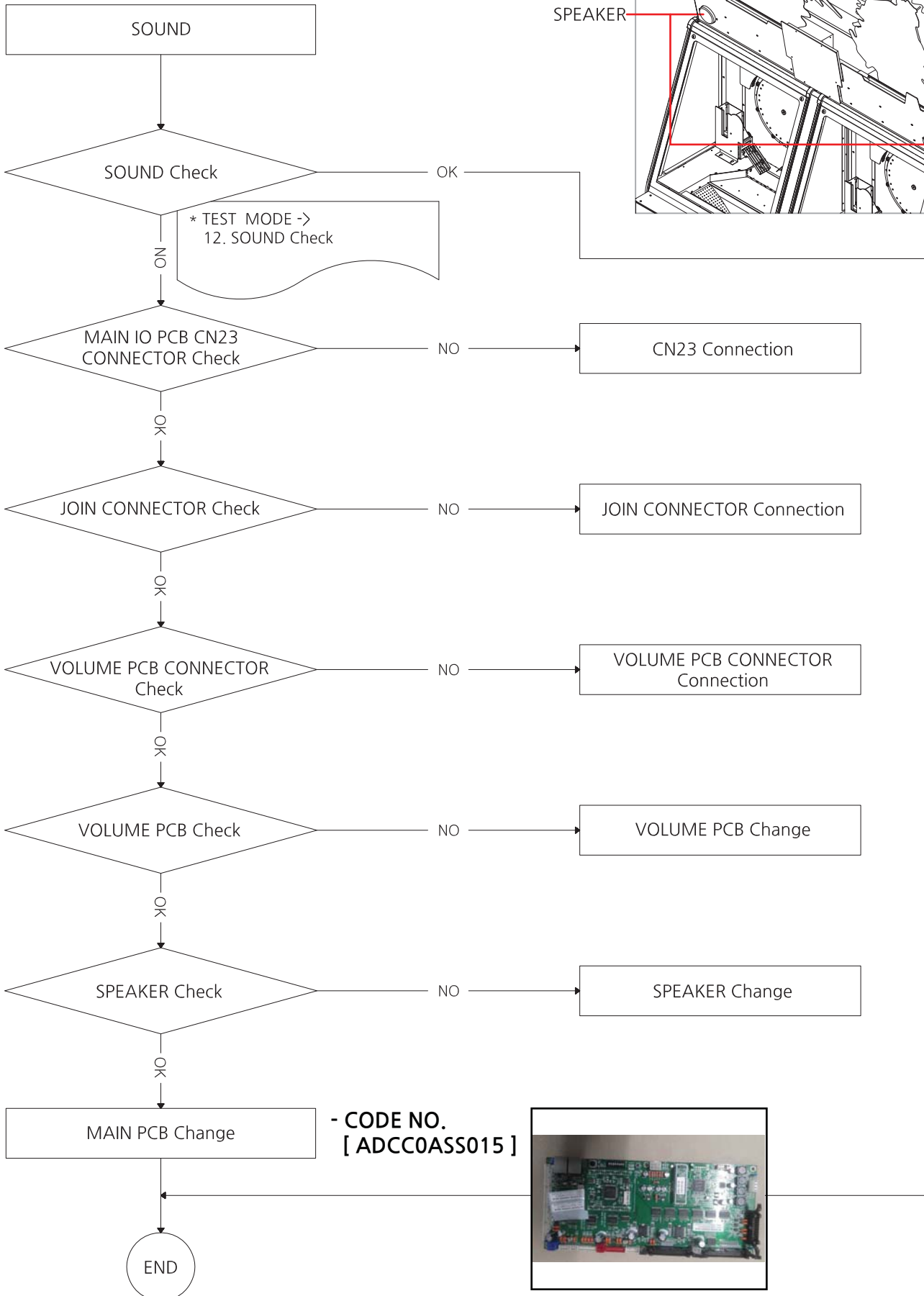

# 6-18. COIN SELECTOR ERROR [1~2P] - ERROR 02

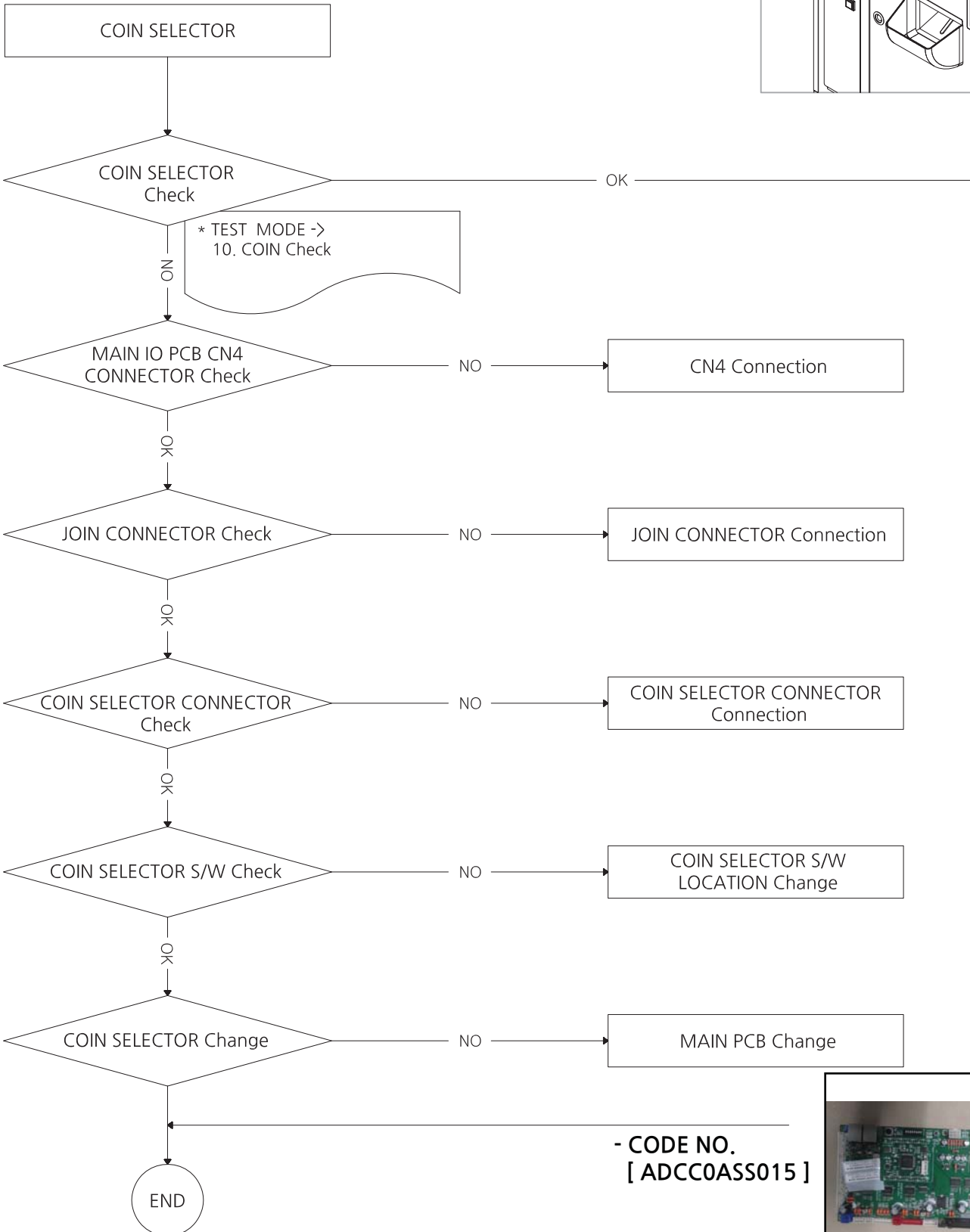
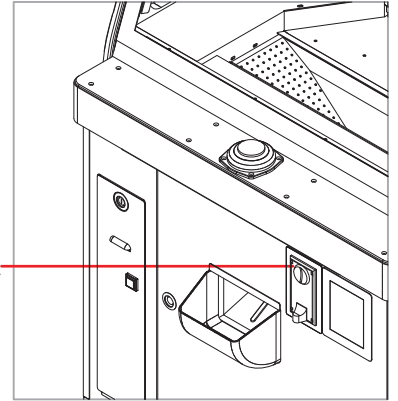

# 6-19. SETUP BUTTON ERROR

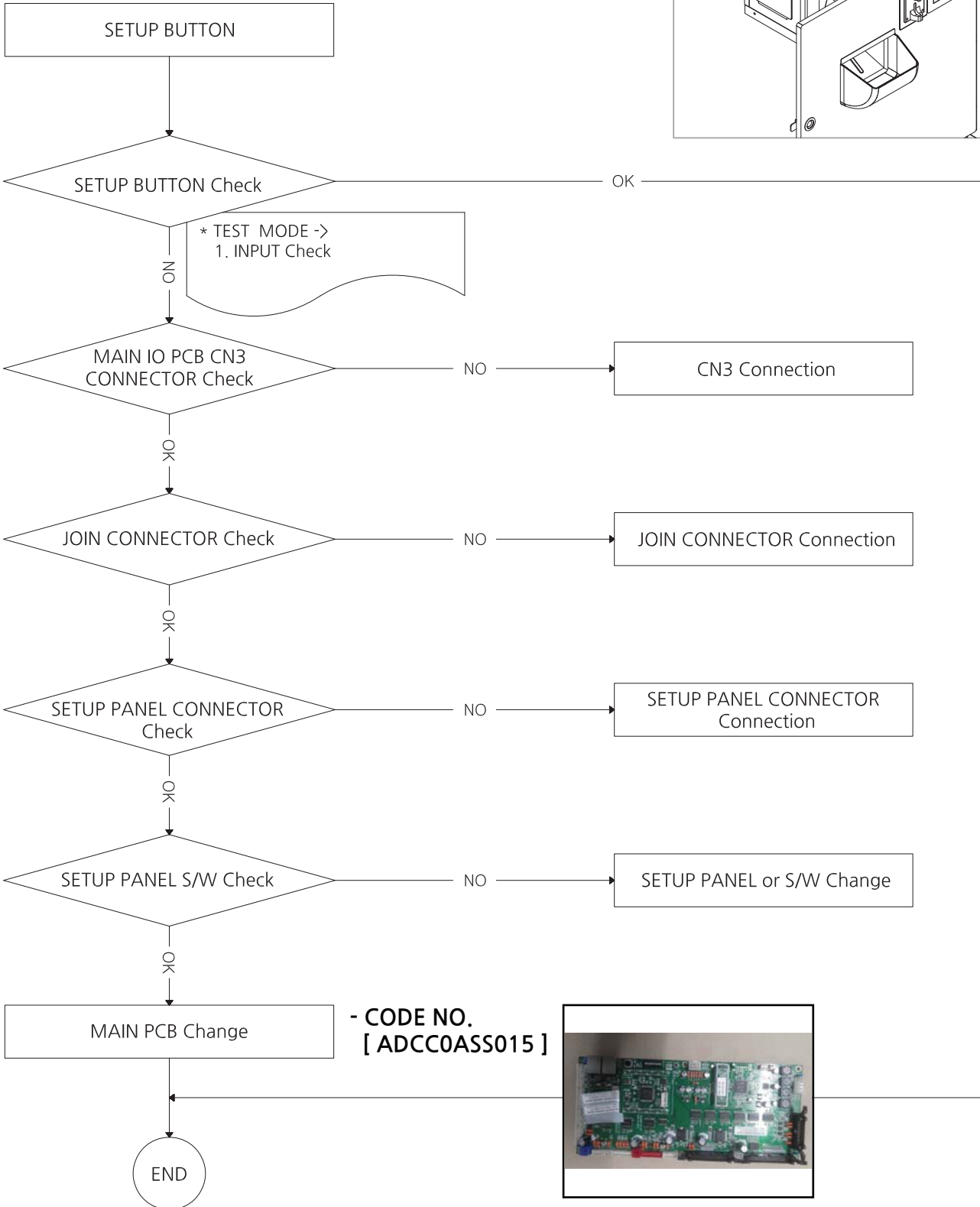
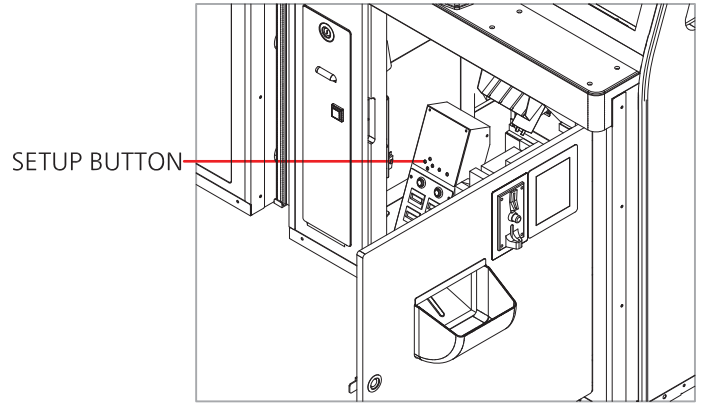

## 6-20. COUNTER ERROR [1~2P]

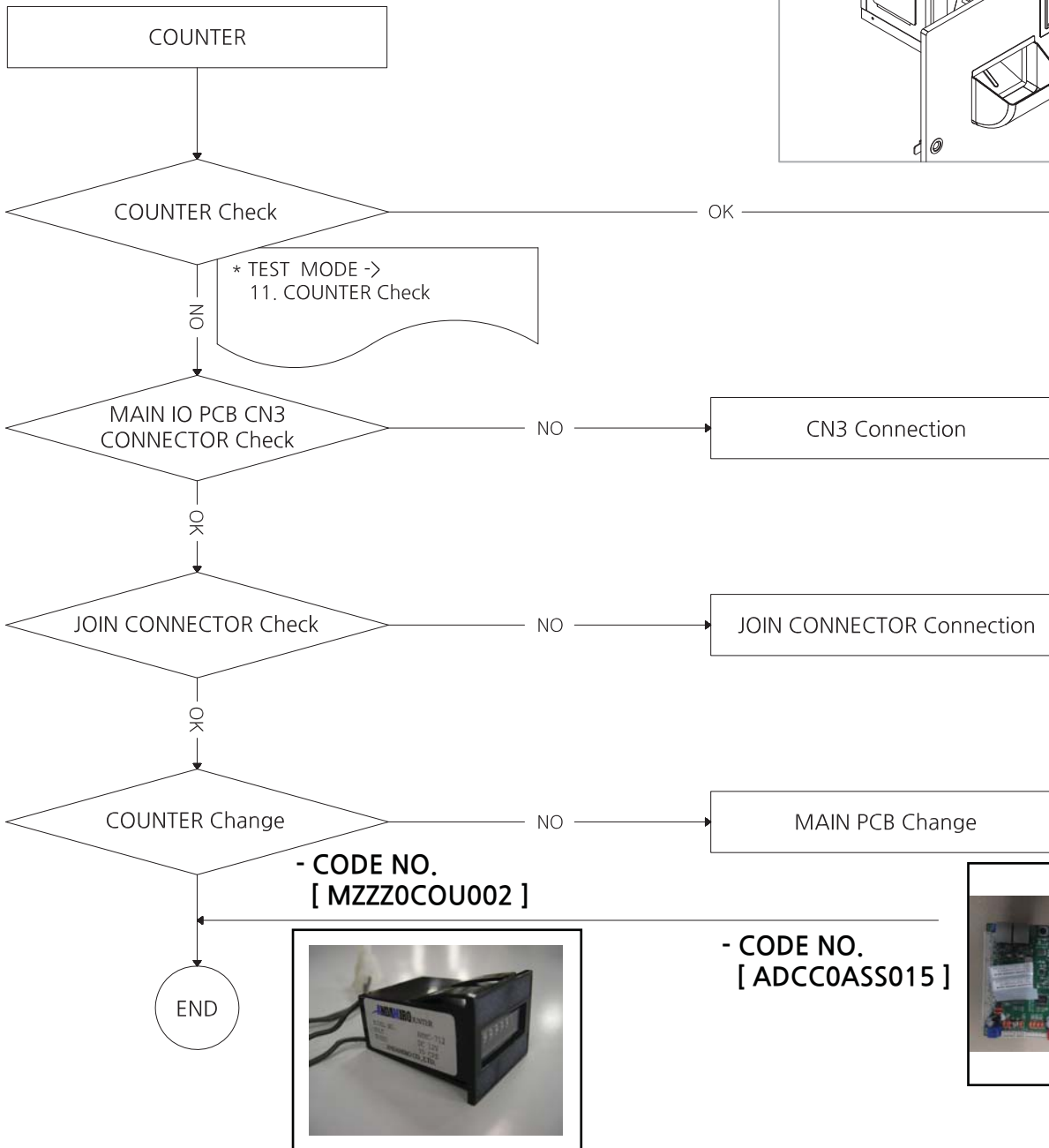
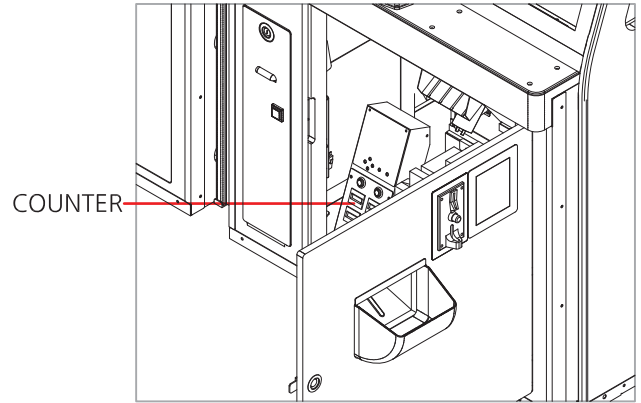



# 7. EXPLODED VIEW

## 7-1. MAIN CABINET PART

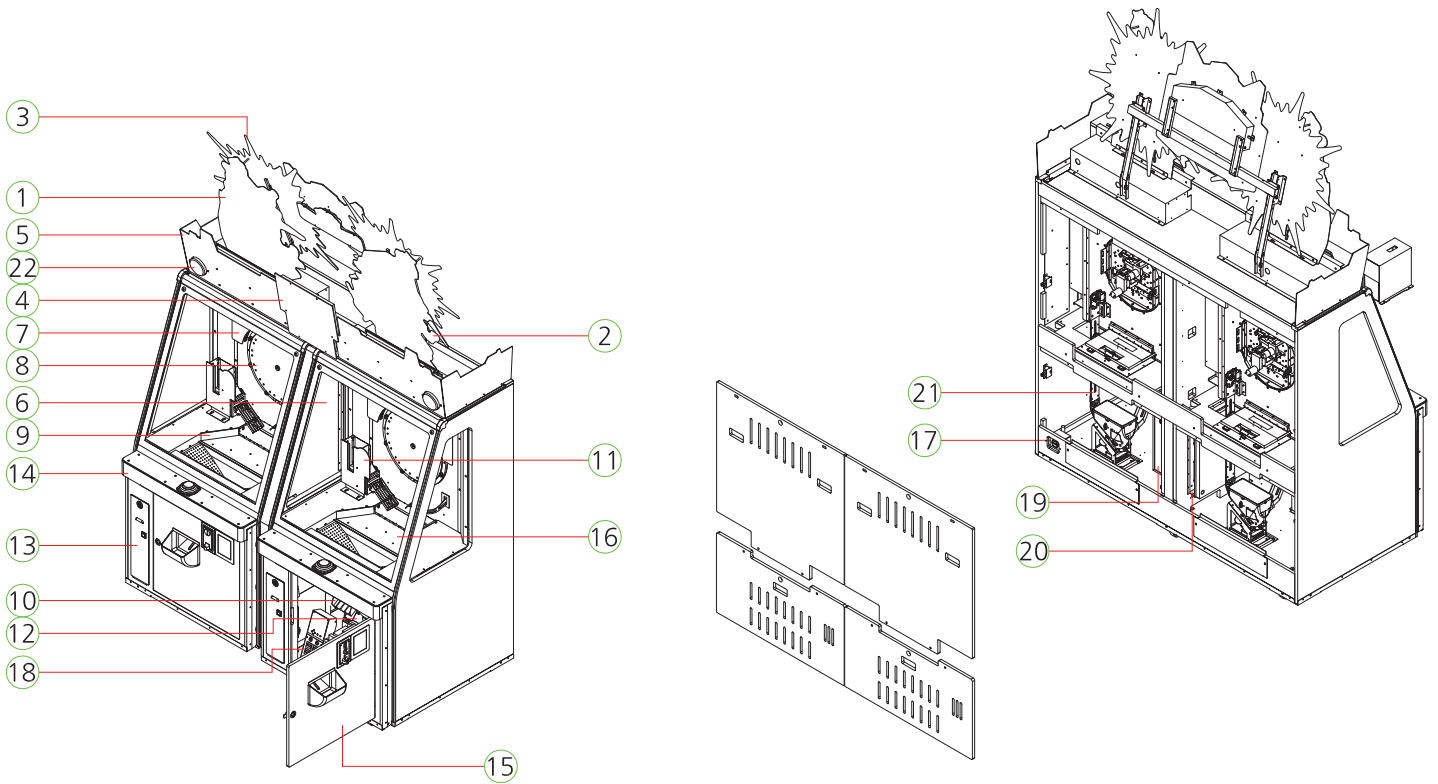

NO.	PART NAME	SPEC.	QUANTITY	CODE NO.
1	BILLBOARD POP-L FRONT PART	-	1	-
2	BILLBOARD POP-R FRONT PART	-	1	-
3	BILLBOARD_TOTAL PART	-	1	-
4	BONUS FND PART	-	1	-
5	CARD DECO LAMP BKT L, R PART	-	2	-
6	CABINET CENTER DECO LIGHT PART	-	1	-
7	SCORE BOARD PANEL PART	-	2	-
8	MEDAL CIRCULATION PART	-	2	-
9	PUSHER PANEL PART	-	2	-
10	FRONT ROLLER PART	-	2	-
11	CARD DISPENSER PART	-	2	-
12	COUNTER HOPPER PART	-	2	-
13	TICKET DOOR PART	-	2	-
14	FRONT TABLE PART	-	2	-
15	FRONT DOOR PART	-	2	-
16	FRONT GLASS DOOR PART	-	2	-
17	AC INPUT PART	-	1	-
18	SETUP PANEL PART	-	1	-
19	SMPS POWER PART	-	1	-
20	MAIN BOARD PCB PART	-	1	-
21	ELEVATOR HOPPER PART	-	2	-
22	SPEAKER	MID4.5"+TW1/2" 8Ω	2	MZZZOSPE021

## 7-2. BILLBOARD POP-L FRONT PART

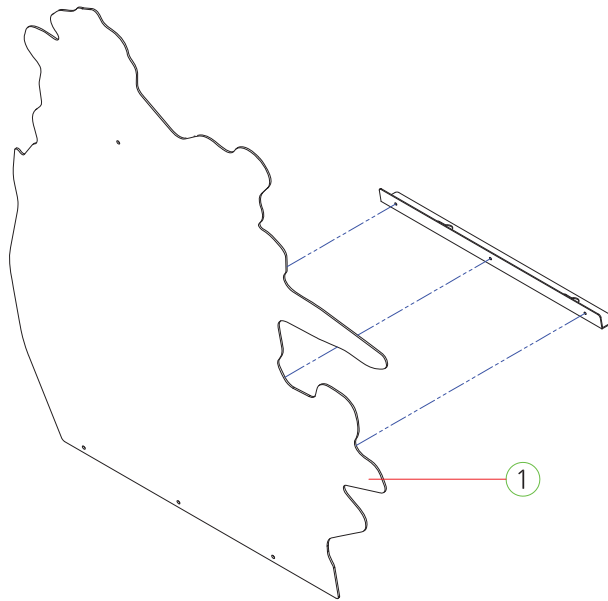

NO.	PART NAME	SPEC.	QUANTITY	CODE NO.
1	BILLBOARD MAIN POP-L	PET-2.0t	1	MDC20ACR016

## 7-3. BILLBOARD POP-R FRONT PART

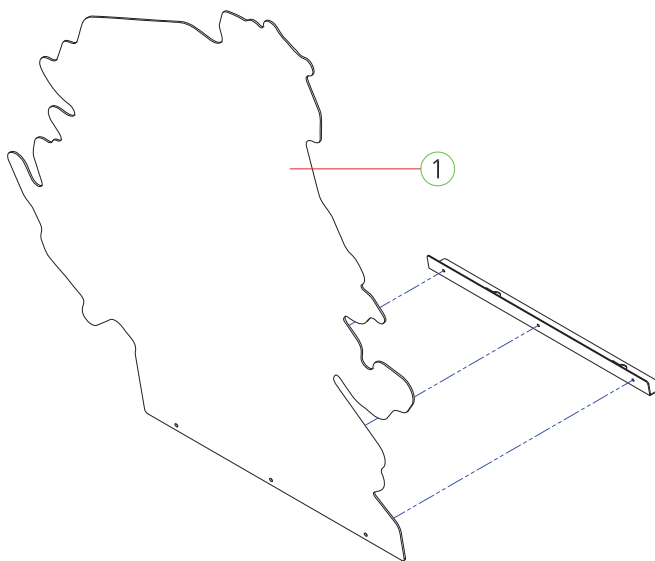

NO.	PART NAME	SPEC.	QUANTITY	CODE NO.
1	BILLBOARD MAIN POP-R	PET-2.0t	1	MDC20ACR017

# 7-4. BILLBOARD\_TOTAL PART

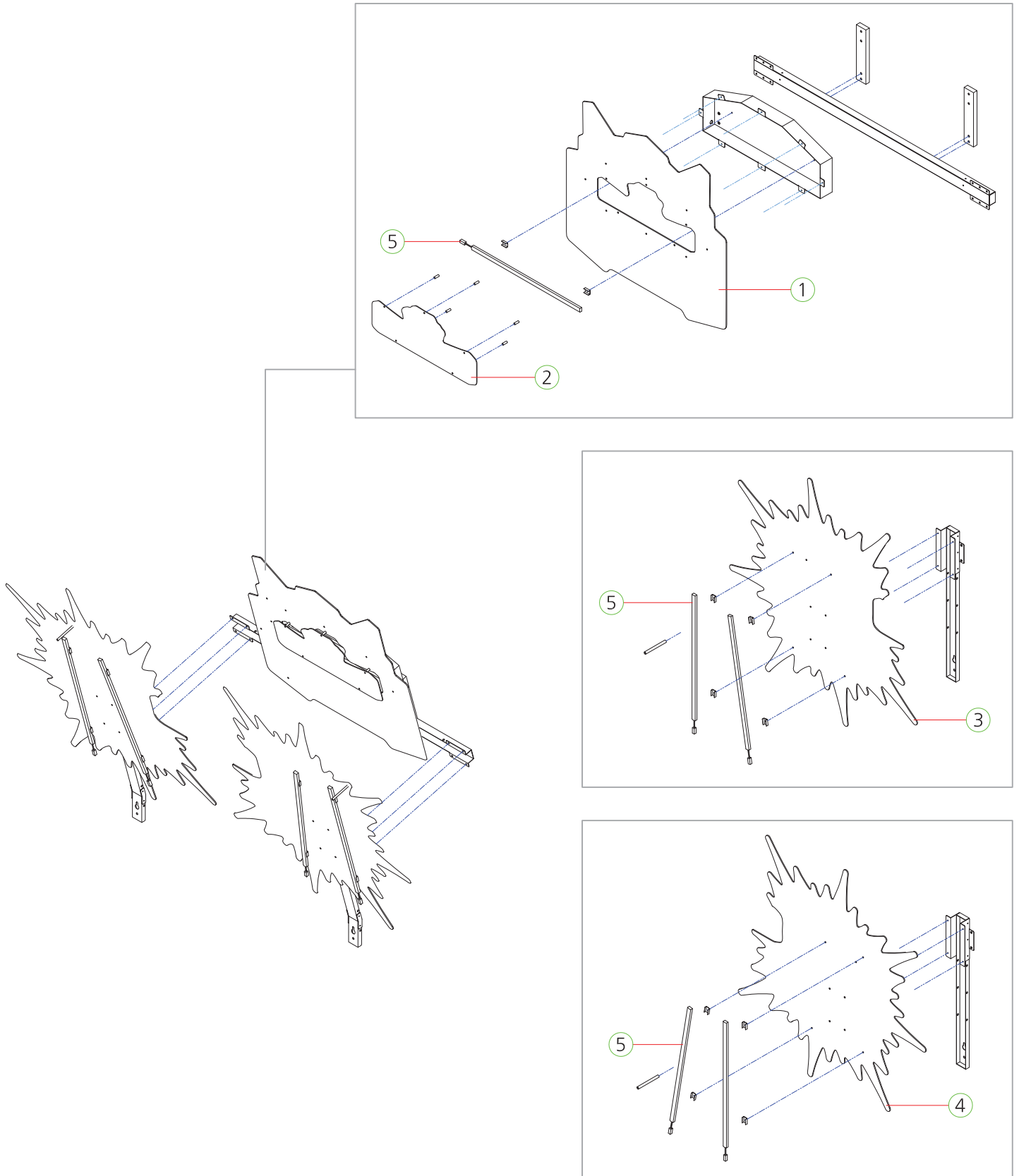

NO.	PART NAME	SPEC.	QUANTITY	CODE NO.
1	BILLBOARD CENTER POP	FORMAX-3.0t	1	MDC20ACR014
2	BILLBOARD SUB POP-CENTER	PET-2.0t	1	MDC20ACR015
3	BILLBOARD SUB POP-L	FORMAX-3.0t	1	MDC20ACR012
4	BILLBOARD SUB POP-R	FORMAX-3.0t	1	MDC20ACR013
5	LED BAR 12V ASS'Y	460mm	5	AZZZ0PCB124

## 7-5. BONUS FND PART

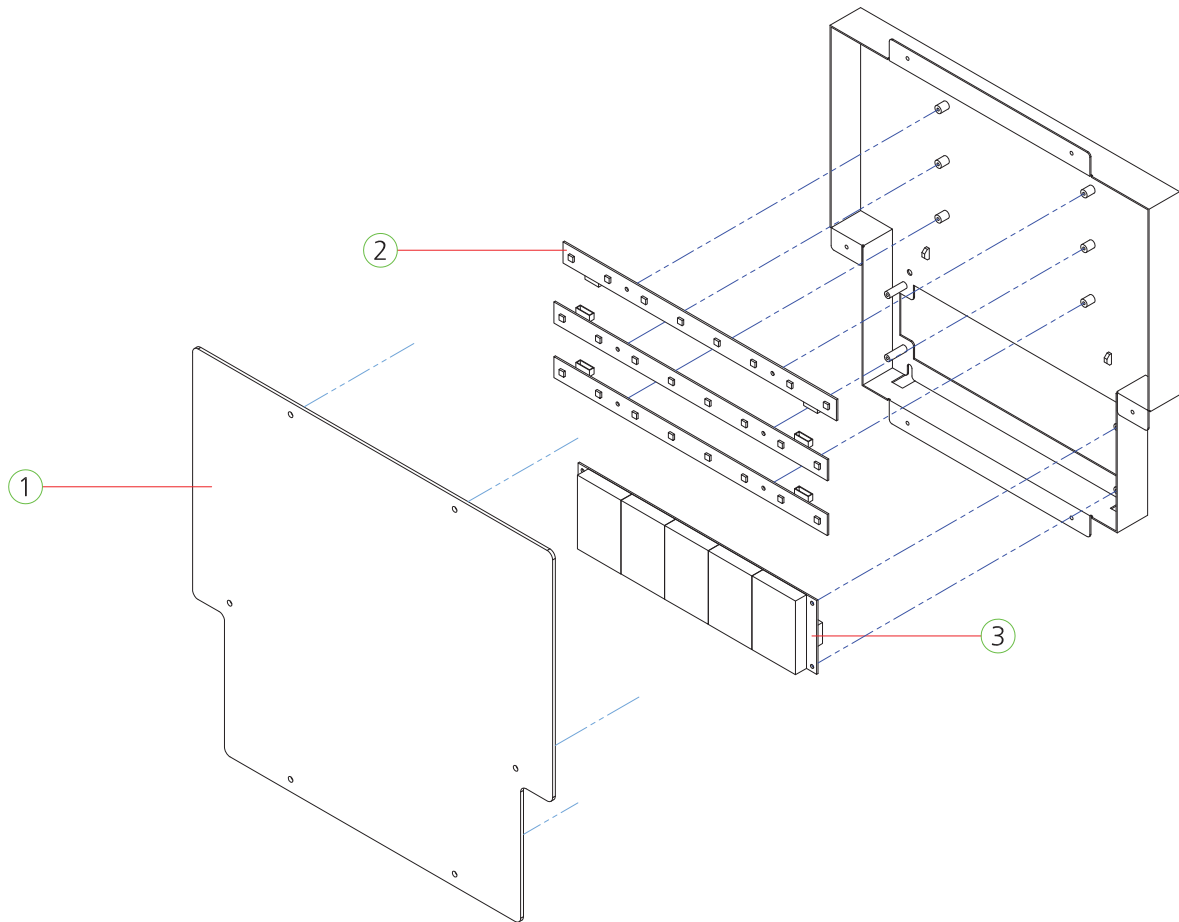

NO.	PART NAME	SPEC.	QUANTITY	CODE NO.
1	BILLBOARD JACKPOT ACRYL	PC-3.0t	1	MDC20ACR001
2	JACKPOT LIGHTING PCB ASS'Y	-	3	ADC20PCB001
3	FND PCB ASS'Y	4870-5(STRAIGHT)	1	AFND0PCB033

## 7-6. SCORE BOARD PANEL PART

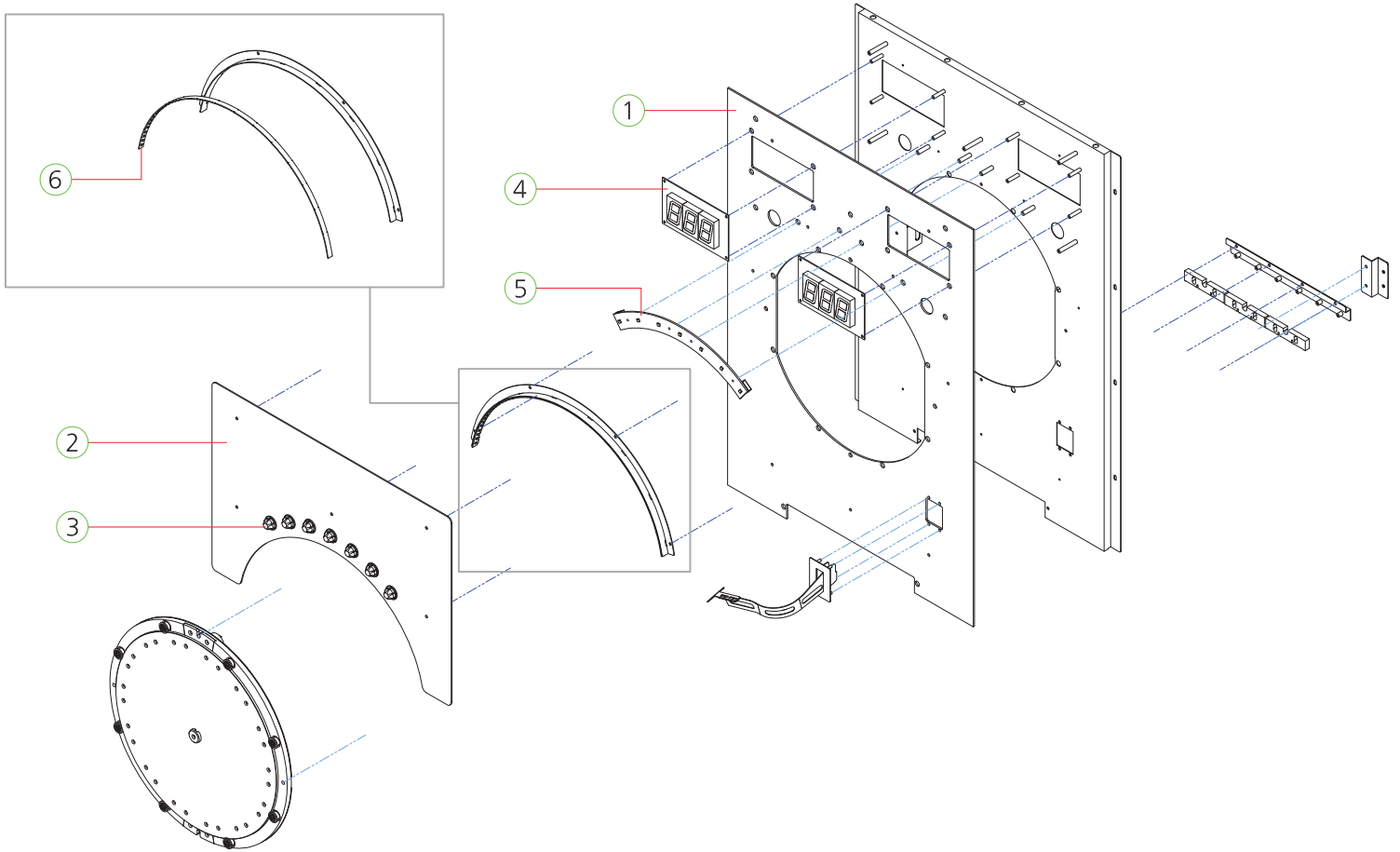

NO.	PART NAME	SPEC.	QUANTITY	CODE NO.
1	SCORE BOARD MAIN ACRYL	ACRYL-3.0t	1	MDC20ACR007
2	SCORE BOARD FND COVER ACRYL	PET-2.0t	1	MDC20ACR006
3	LED CAP	Ø 20	7	MZZ0PLA037
4	BONUS FND PCB ASS'Y	FND-1817-3	2	ASBP0PCB003
5	WHEEL SPIN LED PCB ASS'Y	-	1	ADCC0PCB004
6	FLEX_3528_BLUE_650_L	T3528 TOP300	1	MELE0LED042

## 7-7. MEDAL CIRCULATION PART

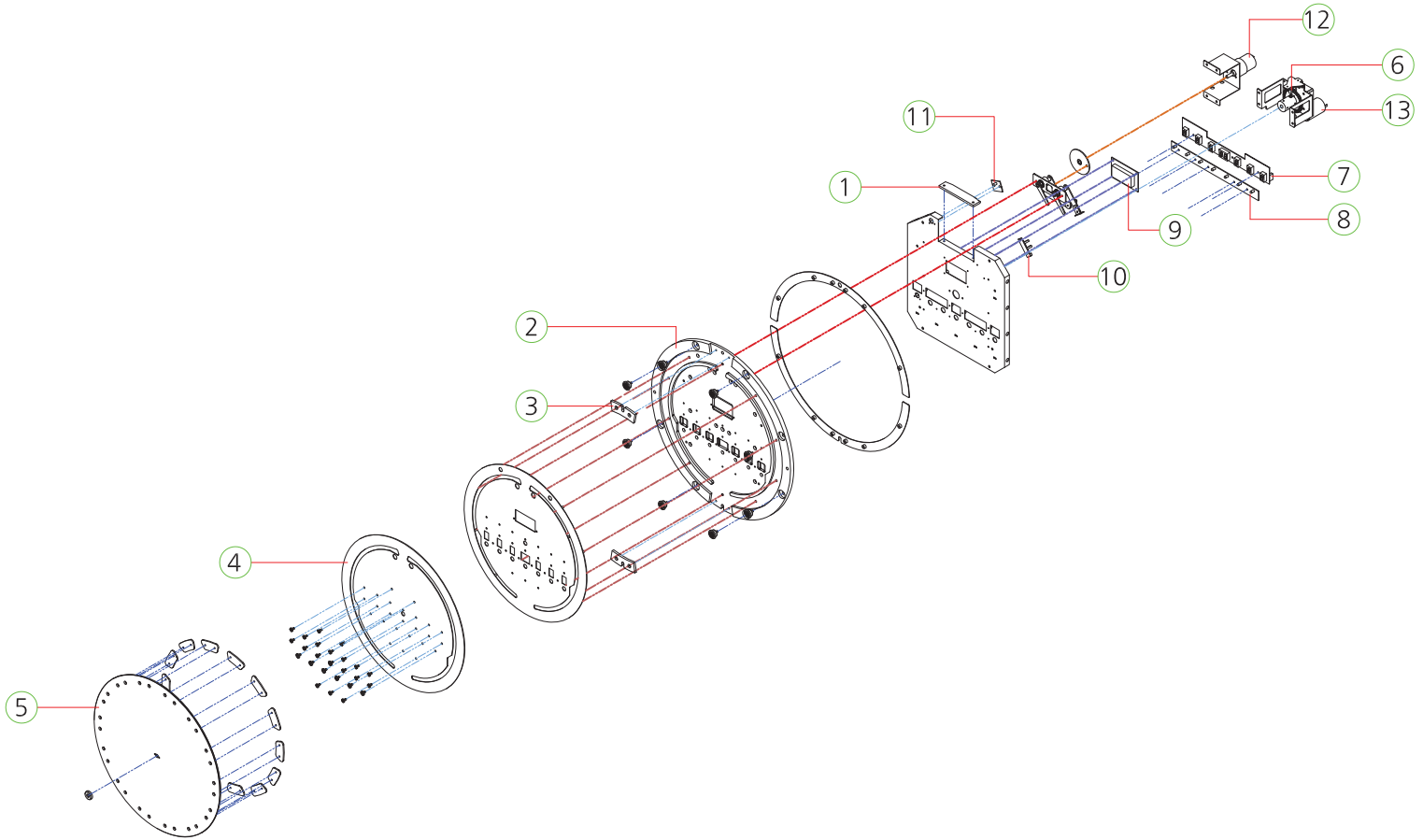

NO.	PART NAME	SPEC.	QUANTITY	CODE NO.
1	WIPER WING GUIDE BLOCK	ACRYL-5.0t	1	MDCC0ACR021
2	MEDAL CIRCULATION NAIL PANEL	PC-5.0t, ACRYL-5.0t	1	MDCC0ACR013
3	MEDAL INLET GUIDE BLOCK	ACRYL-3.0t	2	MDCC0ACR031
4	MEDAL CIRCULATION FRONT COVER	ACRYL-1.5t	1	MDCC0ACR025
5	MEDAL CIRCULATION OUTER RING	PC-4.5t	1	MDCC0ACR014
6	PHOTO INT1(ANGLE) PCB ASS'Y	-	1	AZZZ0PCB103
7	MEDAL CIRCULATION FND PCB ASS'Y	-	1	ADCC0PCB009
8	MEDAL CIRCULATION CHECK-A PCB ASS'Y	-	1	ADCC0PCB006
9	FND PCB ASS'Y	2029-3	1	AFND0PCB028
10	PHOTO INT1(ANGLE) PCB ASS'Y	-	1	AZZZ0PCB103
11	MEDAL CIRCULATION CHECK-B PCB ASS'Y	-	1	ADCC0PCB007
12	DC MOTOR	KGC-0060-ND3657U2_24V	1	MZZZ0MOT109
13	DC MOTOR	KGE-0687-ND3448S1	1	MZZZ0MOT108

## 7-8. PUSHER PANEL PART

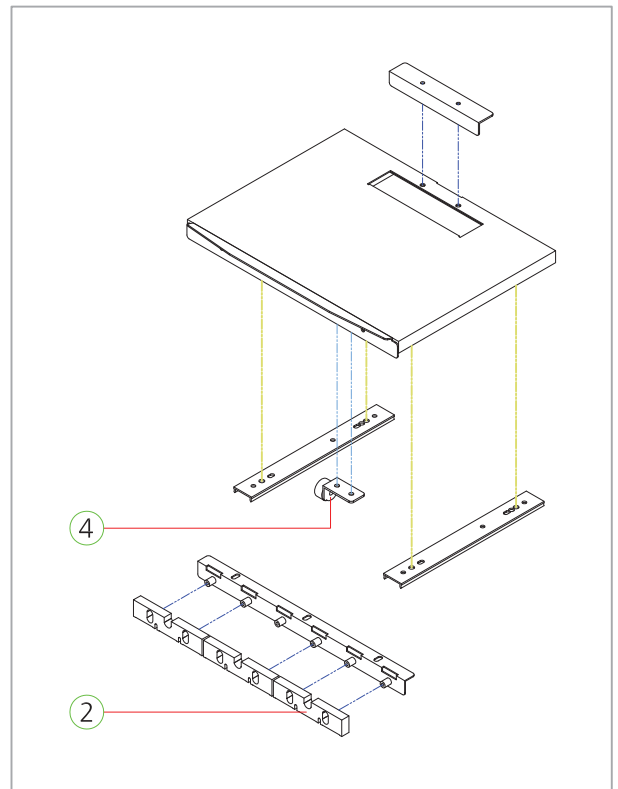
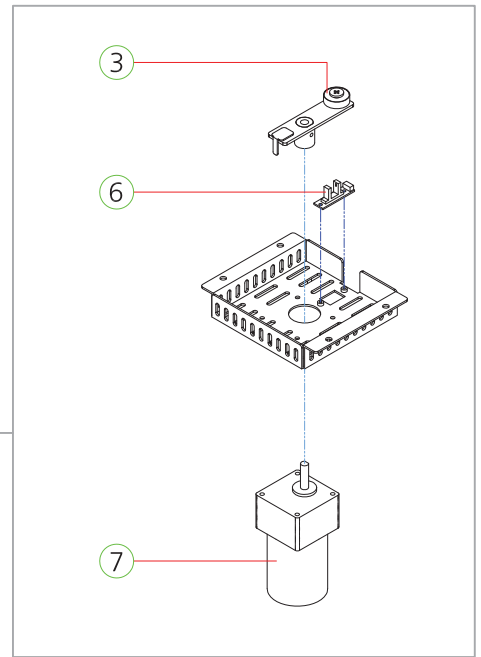
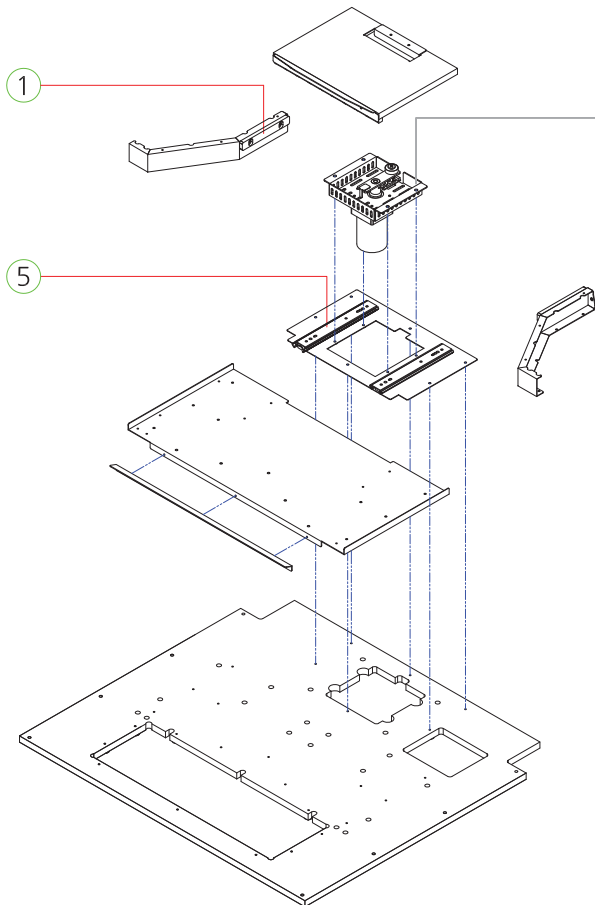

NO.	PART NAME	SPEC.	QUANTITY	CODE NO.
1	SIDE PAYOUT GUIDE MOLD	-	2	MDCC0PLA010
2	PUSHER BODY COIN BAFFLE	ACETAL	1	MSBP0PRO001
3	BEARING	600ZZ	1	MZZZ0BEA095
4	PUSHER BEARING	696ZZ + $\Phi 20 \times W8$ (ACETAL)	1	MSBP0PRO002
5	PUSHER GUIDE RAIL	200mm	2	MSBP0ZZZ011
6	PHOTO INT-1 ASS'Y	-	1	ACIR0PCB011
7	AC MOTOR [120V]	K6IG6NU	1	MZZZ0MOT085
	AC MOTOR [220V]	K6IG6NC	1	MZZZ0MOT095

## 7-9. FRONT ROLLER PART

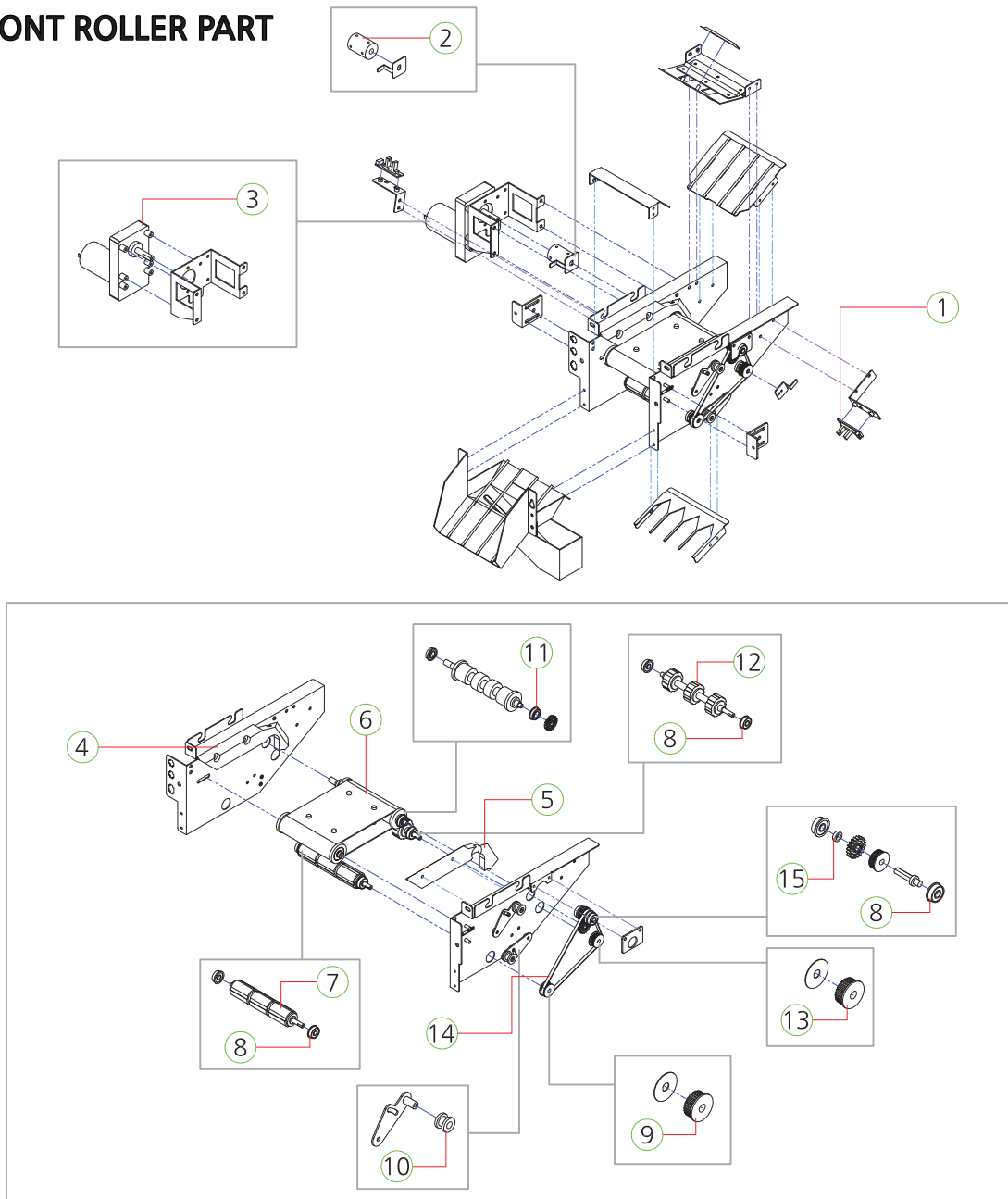

NO.	PART NAME	SPEC.	QUANTITY	CODE NO.
1	PHOTO INT-1 PCB ASS'Y	-	2	ACIROPCB011
2	COUPLING	CR050	2	MSBP0PRO015
3	MOTOR	KGV-0060 ND3657W1	1	MZZZ0MOT087
4	FRONT ROLLER GUIDE MOLD-L	-	1	MDCC0PLA007
5	FRONT ROLLER GUIDE MOLD-R	-	1	MDCC0PLA008
6	FRONT ROLLER CONVEYOR BELT	URETHANE	1	MZZZ0BEL021
7	FRONT ROLLER RUBBER HOUSING-A	-	3	MZZZ0RUB019
8	BEARING	F606ZZ	4	MZZZ0BEA073
9	TIMMING PULLEY_A	-	1	MZZZ0MOL002
10	TIMMING BELT TENSION ROLLER	ACETAL	2	MSBP0PRO017
11	BEARING	F689ZZ	2	MZZZ0BEA109
12	FRONT ROLLER RUBBER HOUSING-B	-	3	MZZZ0RUB020
13	TIMMING PULLEY_A	-	1	MZZZ0MOL002
14	TIMMING BELT	170MXL, W4.8 URETHANE	2	MZZZ0BEL020
15	FRONT ROLLER SHAFT DUSH	ACRYL-3.0t	1	MSBP0ACR056



## 7-10. CARD DISPENSER PART

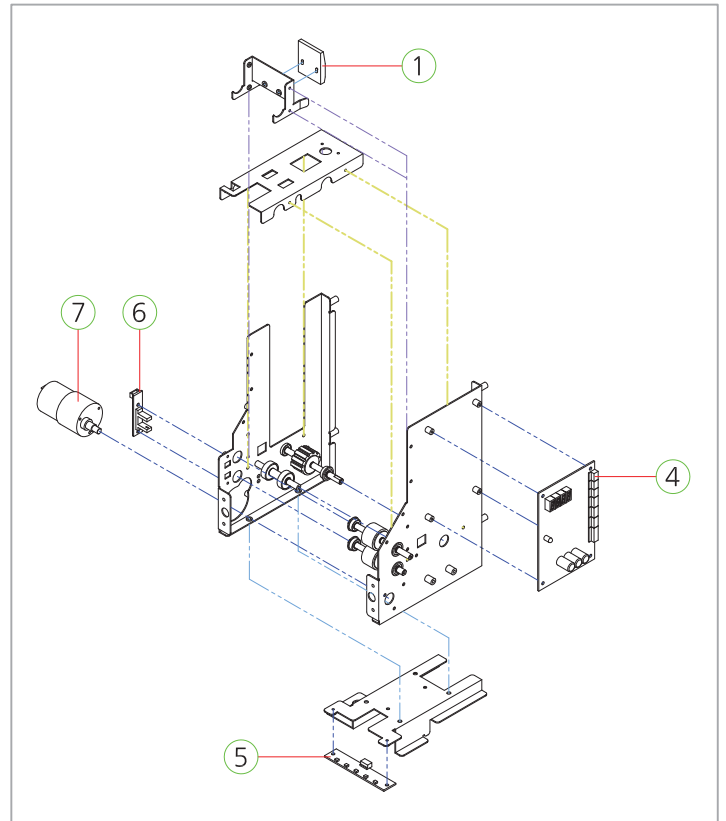
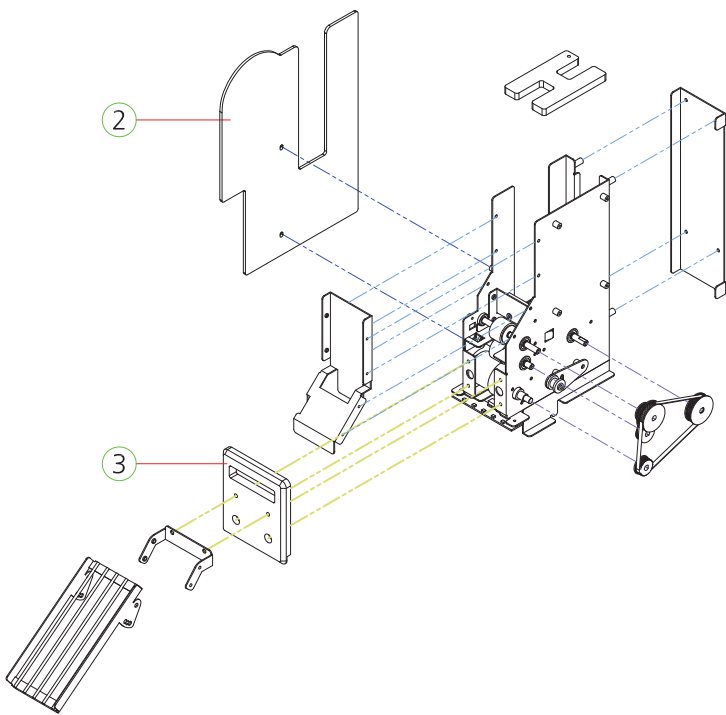

NO.	PART NAME	SPEC.	QUANTITY	CODE NO.
1	CARD OUTLET GUIDE BLOCK	ABS	1	MZZZ0PLA042
2	CARD DISPENSER DECO ACRYL	ACRYL-3.0t	1	MDCC0ACR001
3	CARD DISPENSER FRONT MASK MOLD	-	1	MDCC0PLA009
4	CARD DISPENSOR I/O PCB ASS'Y	-	1	ASBP0PCB008
5	LED PCB ASS'Y	-	1	AMUM0PCB005
6	PHOTO INT1 (ANGLE) PCB ASS'Y	-	1	AZZZ0PCB103
7	MOTOR	KGC-040-3429C	1	MZZZ0MOT089

## 7-11. ELEVATOR HOPPER PART

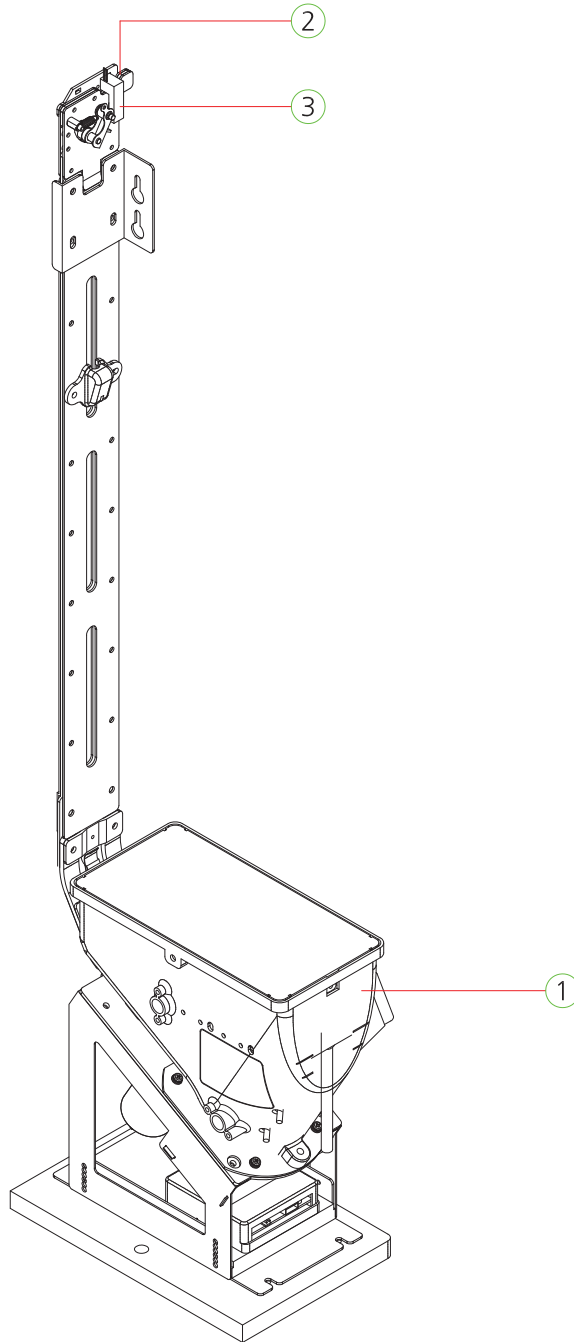

NO.	PART NAME	SPEC.	QUANTITY	CODE NO.
1	ELEVATOR HOPPER BODY ASS'Y	-	1	AZZZ0ELH020
2	ELEVATOR HOPPER TOP	-	1	AZZZ0ELH002
3	ELEVATOR SENSOR ASS'Y	-	1	AZZZ0PCB173

## 7-12. COUNTER HOPPER PART

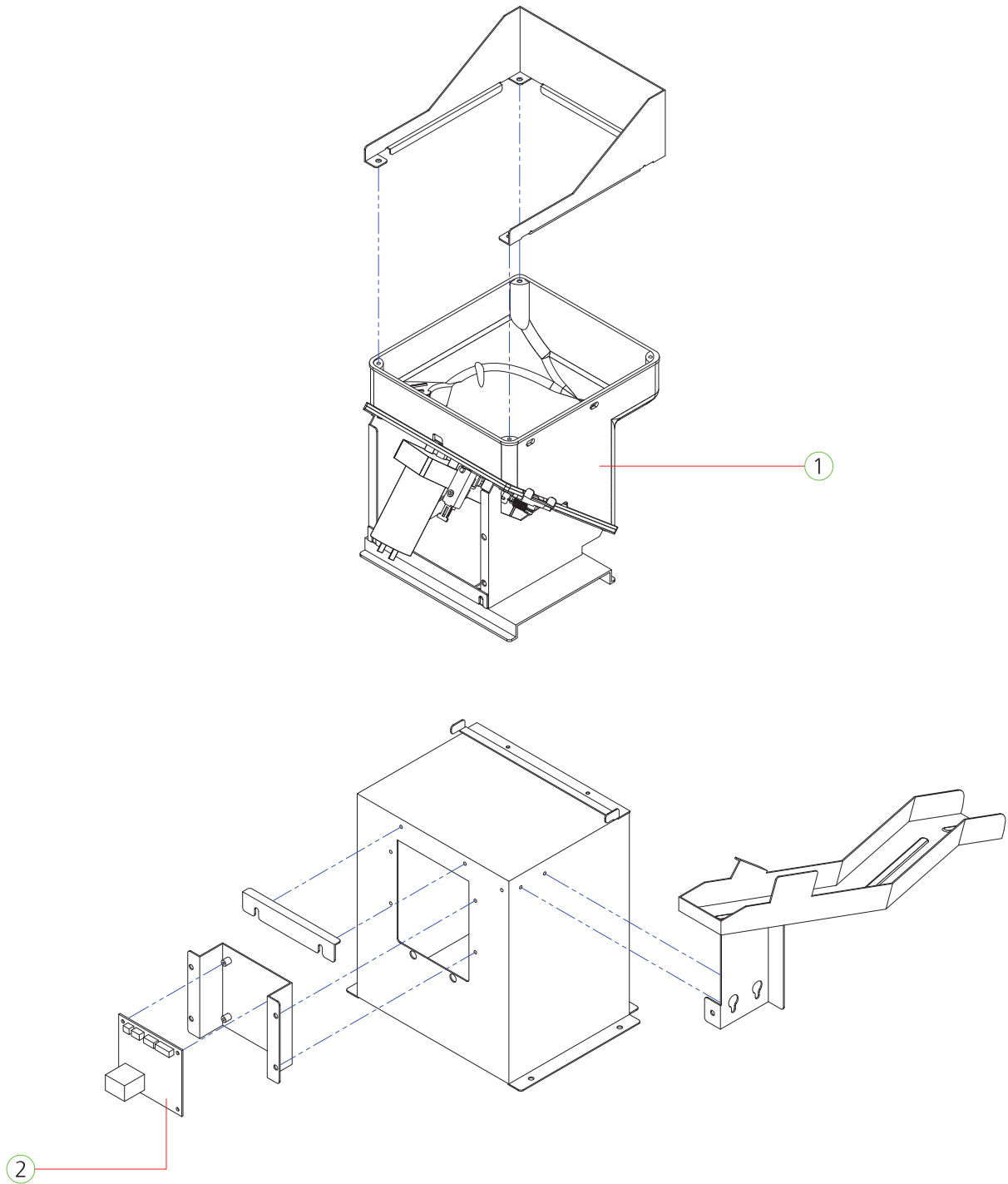

NO.	PART NAME	SPEC.	QUANTITY	CODE NO.
1	HOPPER MACHINE	AM-CH2-1 DC	1	AZZZ0HOP035
2	L6205 V2 HOPPER PCB ASS'Y	-	1	AZZZ0PCB172

## 7-13. TICKET DOOR PART

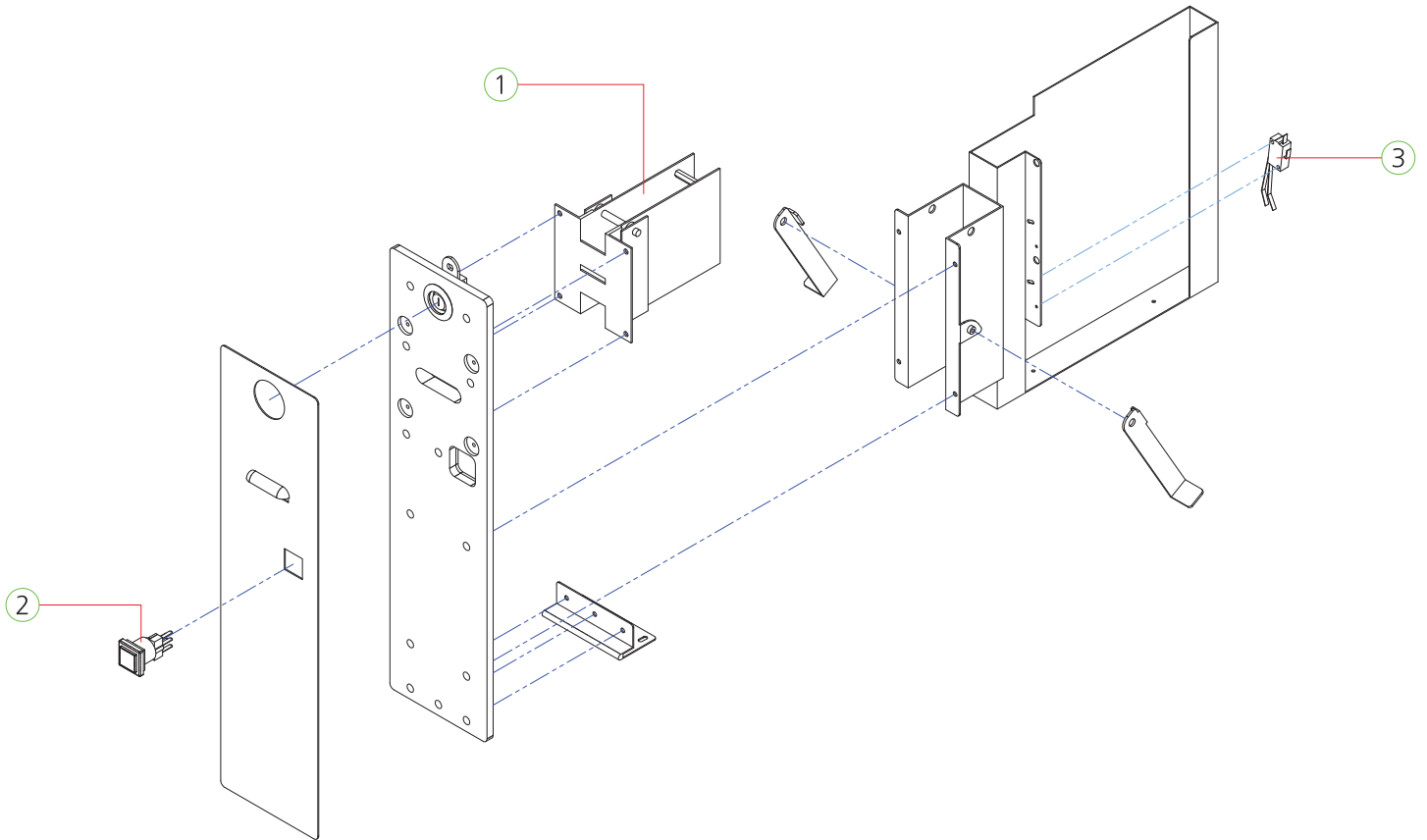

NO.	PART NAME	SPEC.	QUANTITY	CODE NO.
1	TICKET DISPENSER	CLE CL-002Q_270	1	MZZZ0TID010
2	BUTTON	AM1PB-26SH R12D	1	MMUM0BUT002
3	MICRO SWITCH	GSM-V1631A1 [ CEC ]	1	MELE0MIC022

# 7-14. FRONT TABLE PART

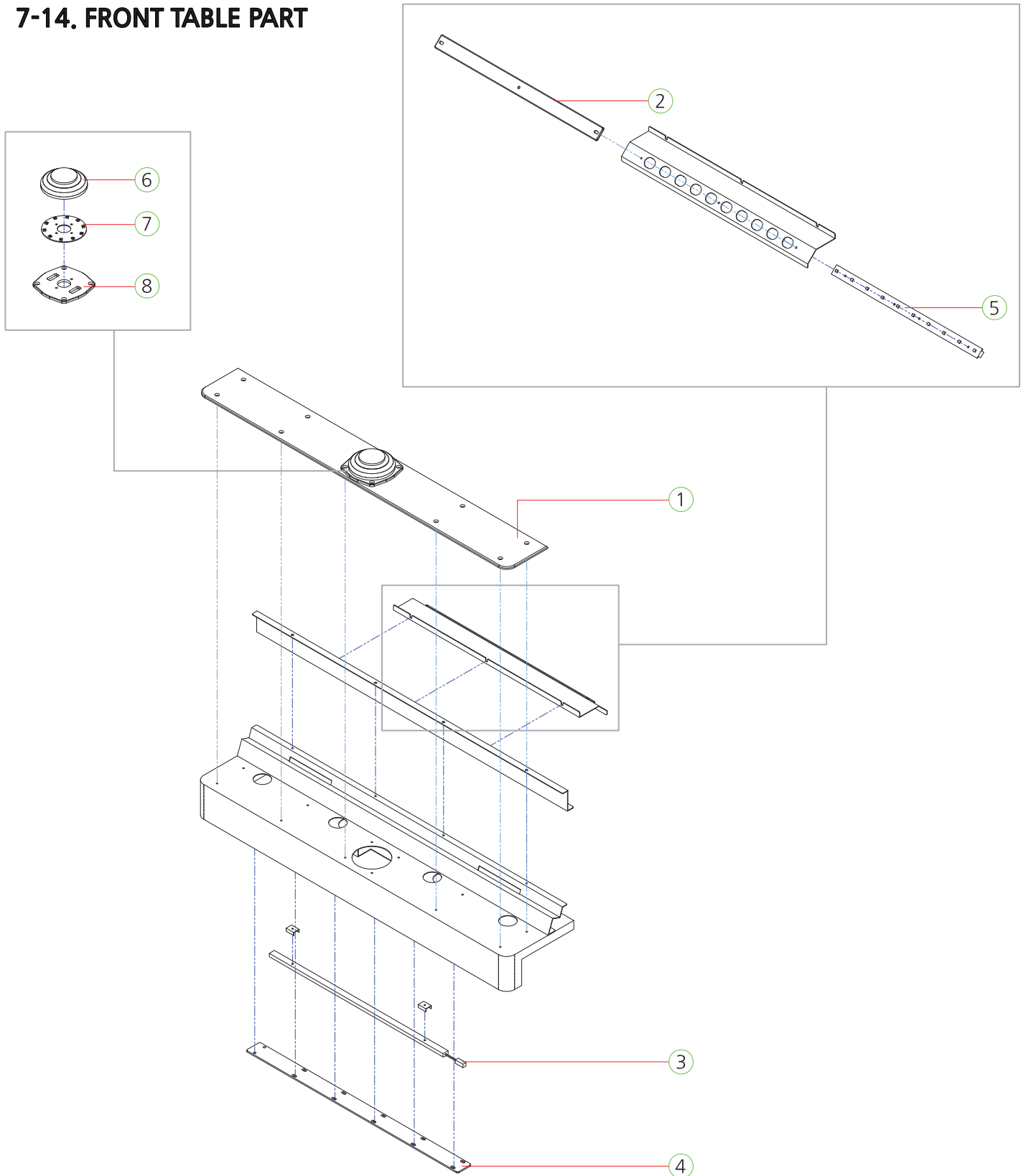

NO.	PART NAME	SPEC.	QUANTITY	CODE NO.
1	FRONT TABLE ACRYL	ACRYL-5.0t	1	MDC20ACR009
2	FRONT TABLE PUSHER LIGHTING ACRYL	ACRYL-3.0t	1	MDC20ACR010
3	LED BAR 12V ASS'Y	460mm	1	AZZZ0PCB124
4	FRONT TABLE LED BAR COVER	ACRYL-3.0t	1	MSBP0ACR035
5	BILLBOARD LED 10 PCB ASS'Y	-	1	ASBP0PCB005
6	BUTTON HOUSING	φ85	1	MZZZ0PLA038
7	BUTTON_LED PCB ASS'Y	-	1	ASHS0PCB002
8	FRONT TABLE BUTTON ACRYL	ACRYL-5.0t	1	MDCC0ACR032

## 7-15. FRONT DOOR PART

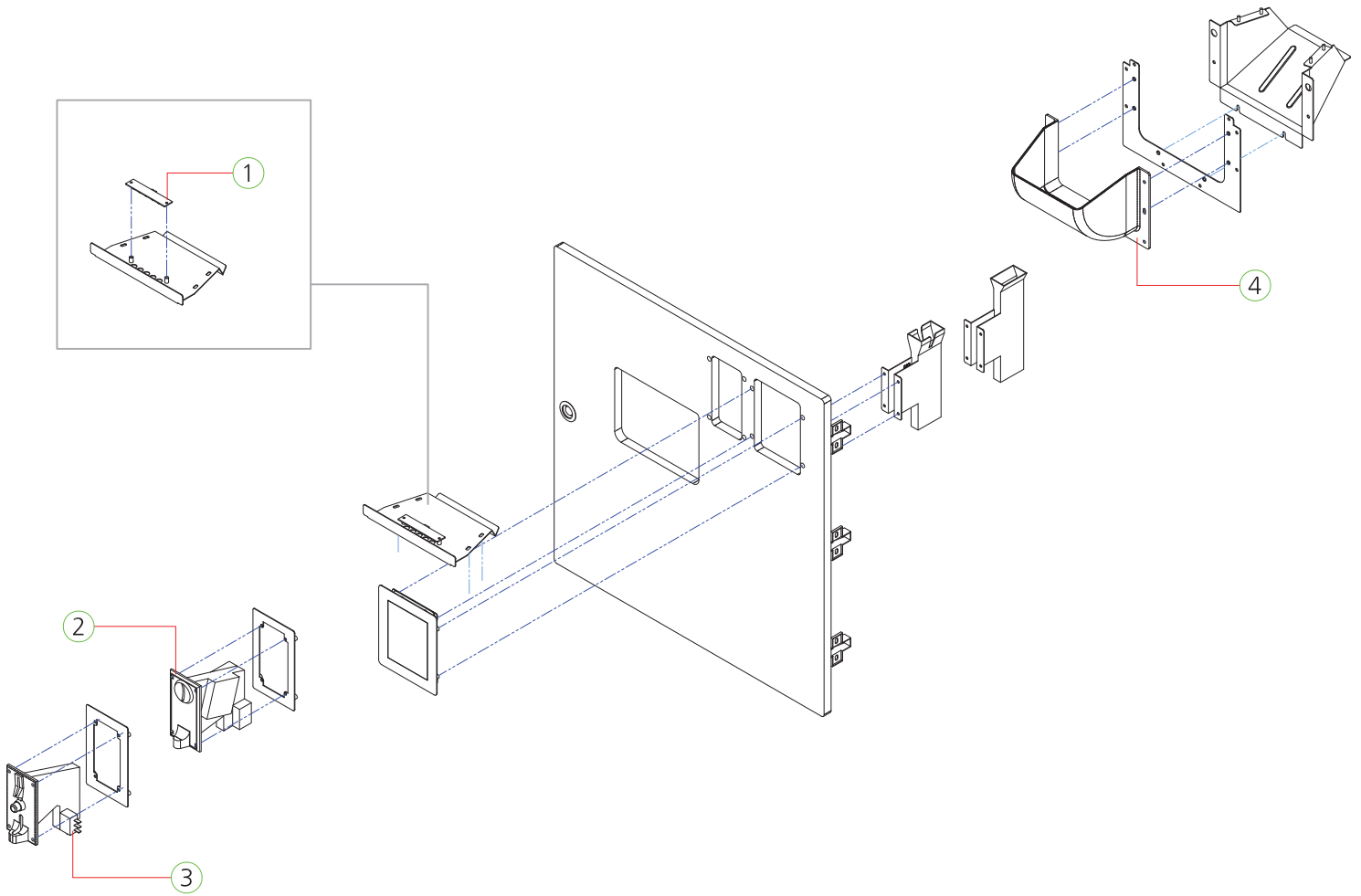

NO.	PART NAME	SPEC.	QUANTITY	CODE NO.
1	LED PCB ASS'Y	-	1	AMUM0PCB005
2	COIN SELECTOR [ INT ]	TW-389	1	MZZZ0COS052
3	COIN SELECTOR [ CEC ]	HS-03CS+SWITCH	1	MZZZ0COS028
4	PRIZE OUTLET COVER MOLD	-	1	MKIS0PLA001

## 7-16. FRONT GLASS DOOR PART

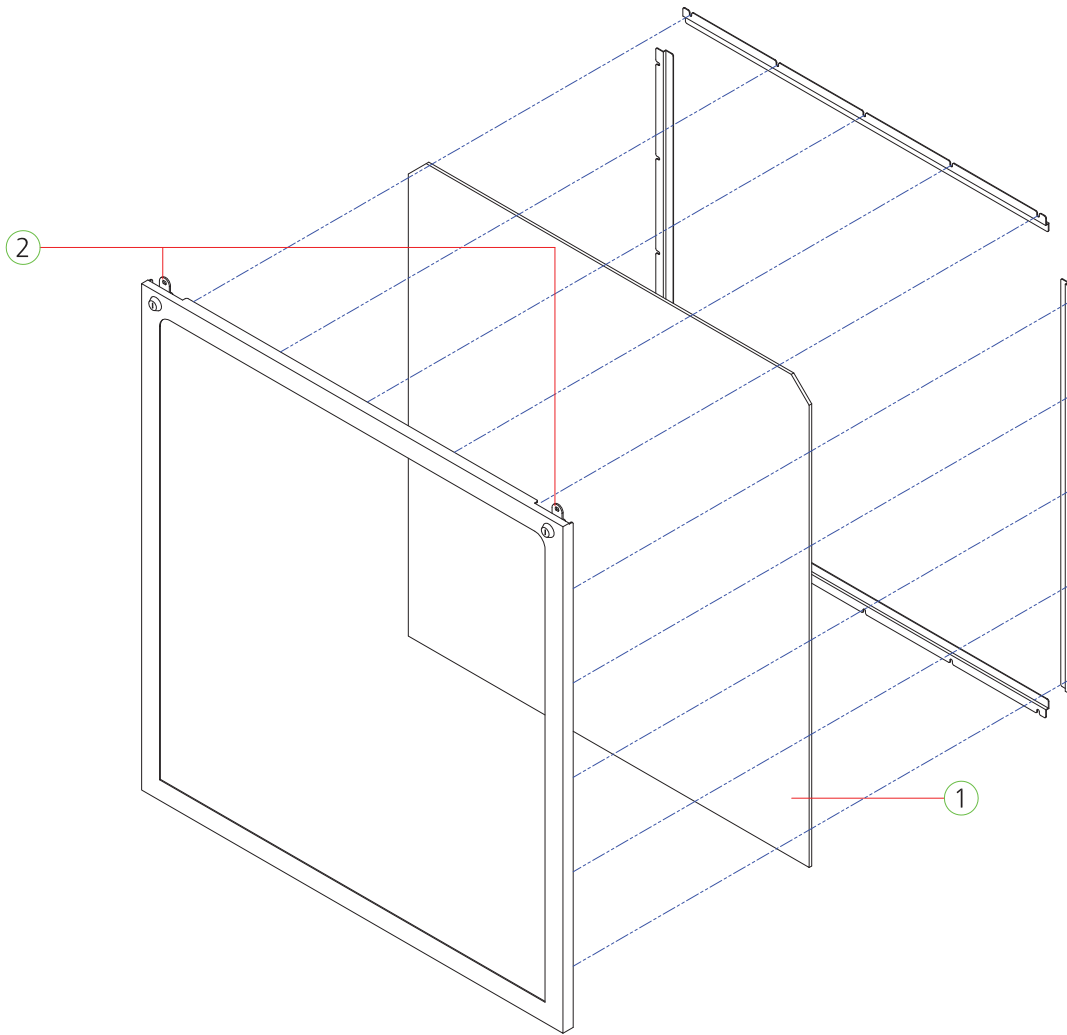

NO.	PART NAME	SPEC.	QUANTITY	CODE NO.
1	FRONT GLASS	GLASS-5T	1	MDC20GLA001
2	KEY ASS'Y [ INT, NAMCO ]	7001	2	MZZZ0KEY076
3	KEY ASS'Y [ CEC ]	CEC C581	2	MZZZ0KEY069

## 7-17. AC INPUT PART

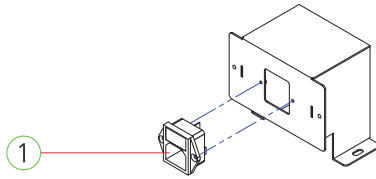

NO.	PART NAME	SPEC.	QUANTITY	CODE NO.
1	AC INPUT	DAC-13H	1	MELE0SWI015

## 7-18. SETUP PANEL PART

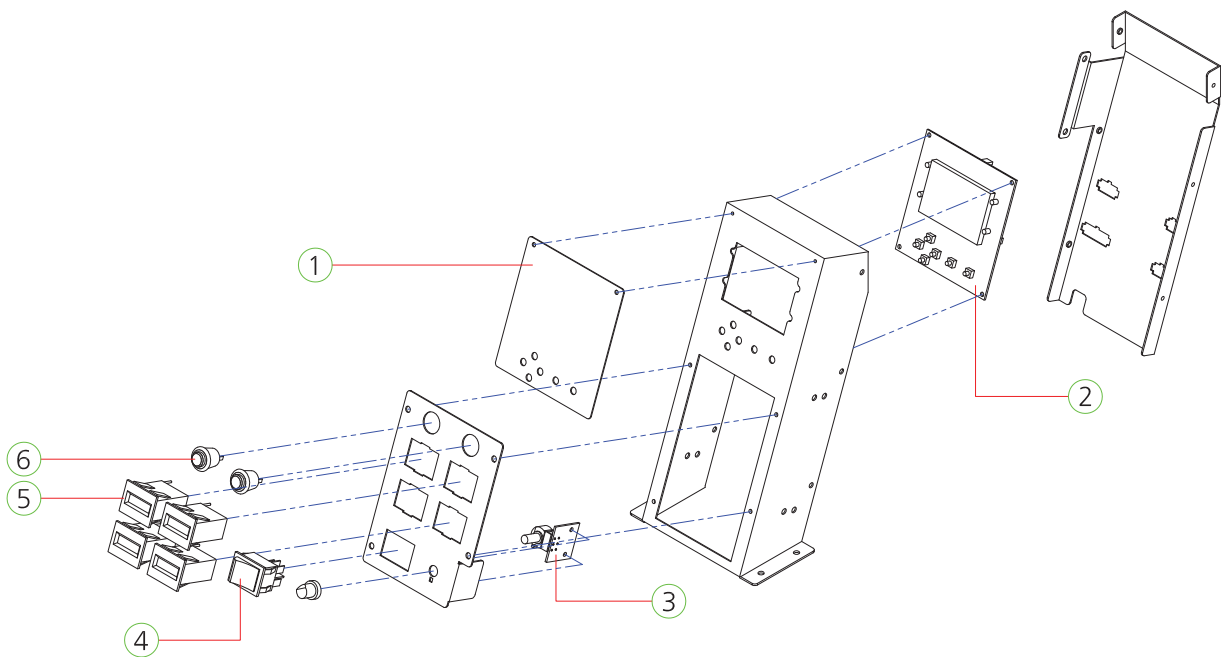

NO.	PART NAME	SPEC.	QUANTITY	CODE NO.
1	SETUP PANEL BKT PET COVER	PET-1.0t	1	MSBP0ACR040
2	SETUP LCD PCB ASS'Y	-	1	AZZZ0PCB113
3	VOLUME PCB ASS'Y	1 VOLUME	1	AHM20PCB016
4	ROCKER SWITCH	R595KDF	1	MELE0SWI021
5	COUNTER	AMMC-712(OA127CL)	4	MZZZ0COU002
6	PUSH SWITCH	HS-412R	2	MELE0PUS006



## 7-19. SMPS POWER PART

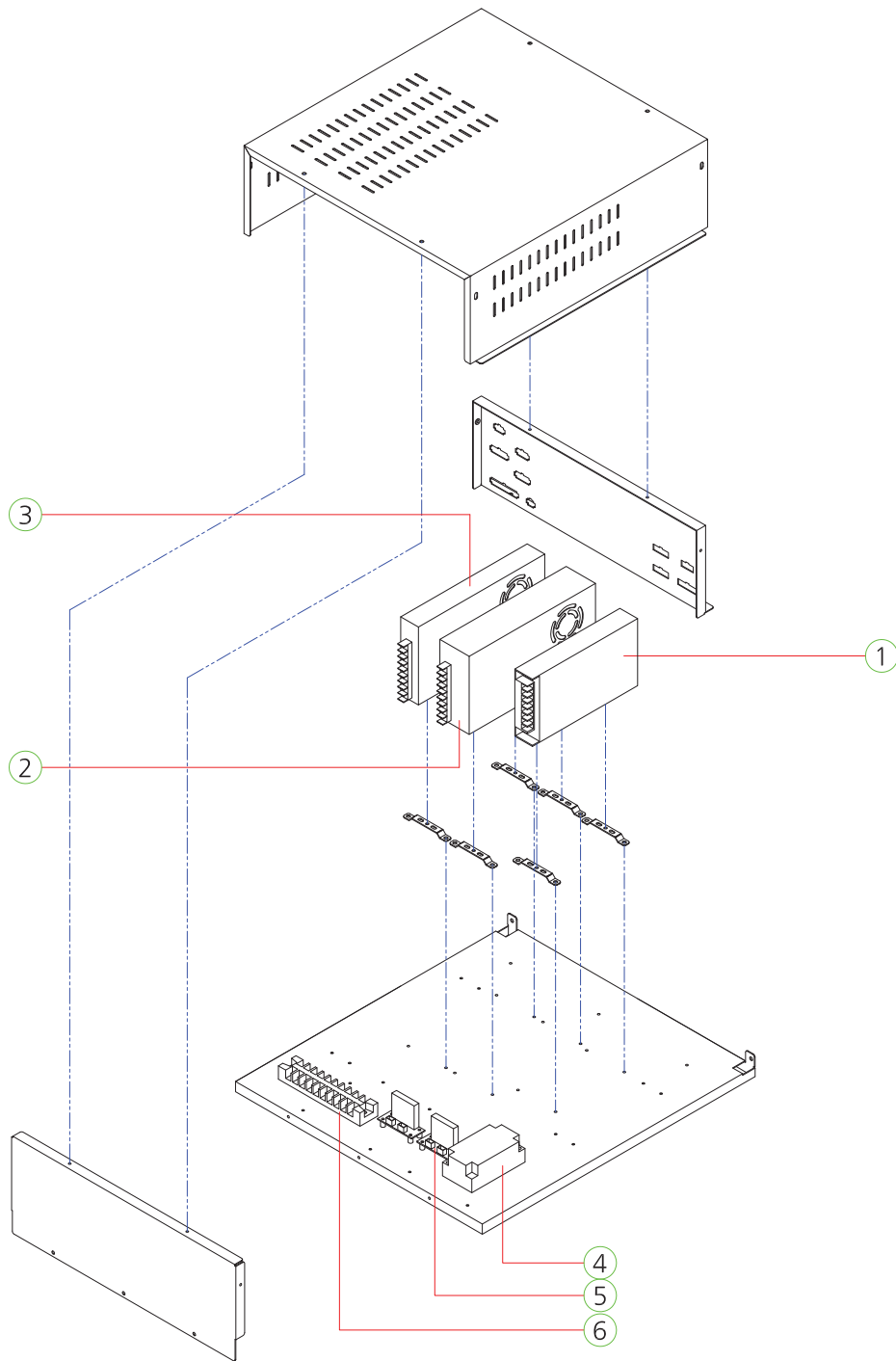

NO.	PART NAME	SPEC.	QUANTITY	CODE NO.
1	POWER SMPS	RSP-100-5	1	MELE0SMP104
2	POWER SMPS	SP-320-24	1	MELE0SMP089
3	POWER SMPS	RSP-320-12	1	MELE0SMP109
4	NOISE FILTER	RNS-2010	1	MELE0NOI009
5	SSR PCB ASS'Y	-	2	AENS0PCB001
6	TERMINAL BLOCK	250V 10P UL_CE	1	MELE0TEB003

## 7-20. MAIN BOARD PCB PART

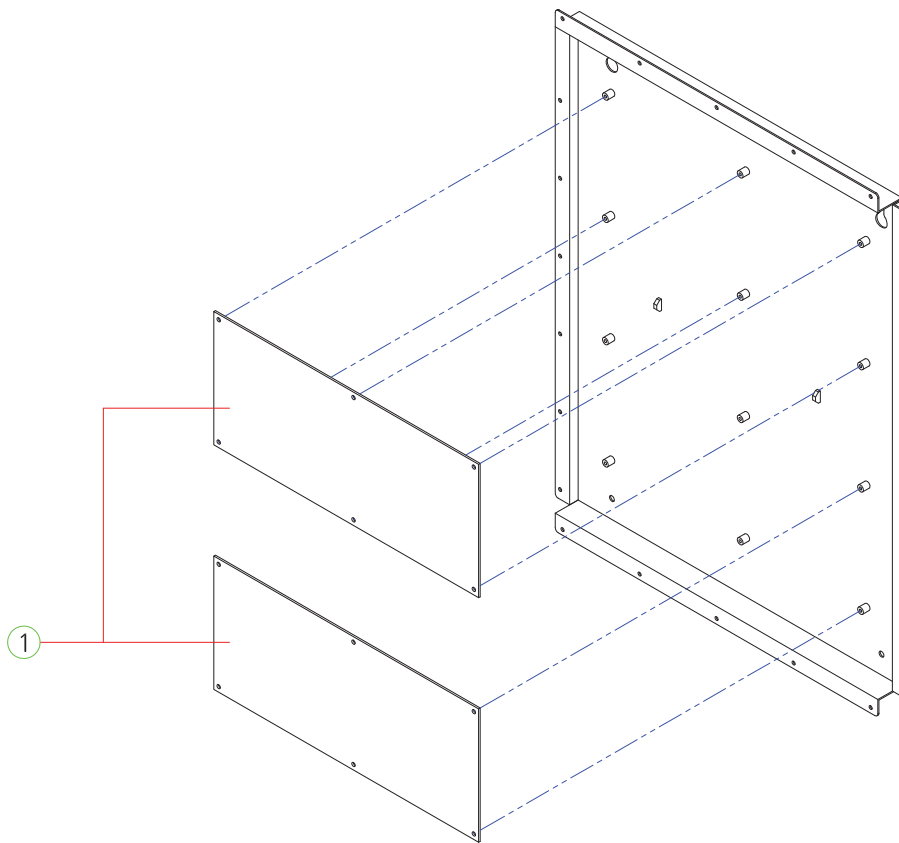

NO.	PART NAME	SPEC.	QUANTITY	CODE NO.
1	MAIN PCB ASS'Y	WITH CPU_SOUND	2	ADCC0ASS015

# 8. PART PICTURE

- BONUS FND PART

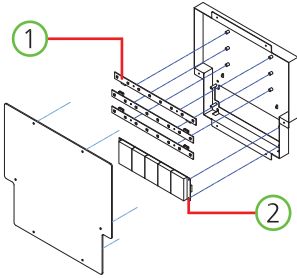

- PUSHER PANEL PART

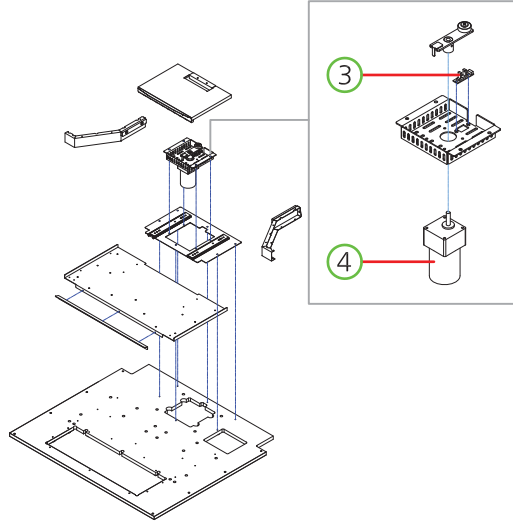

- FRONT ROLLER PART

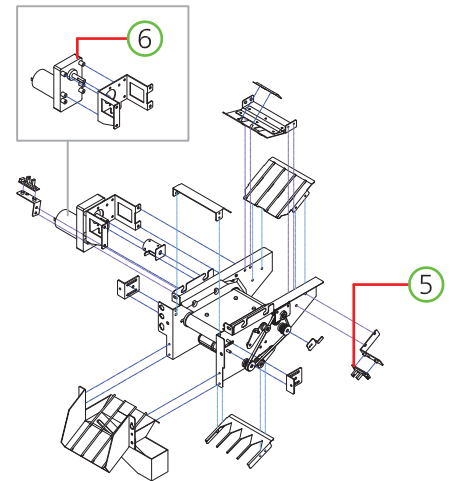

- SCORE BOARD PANEL PART

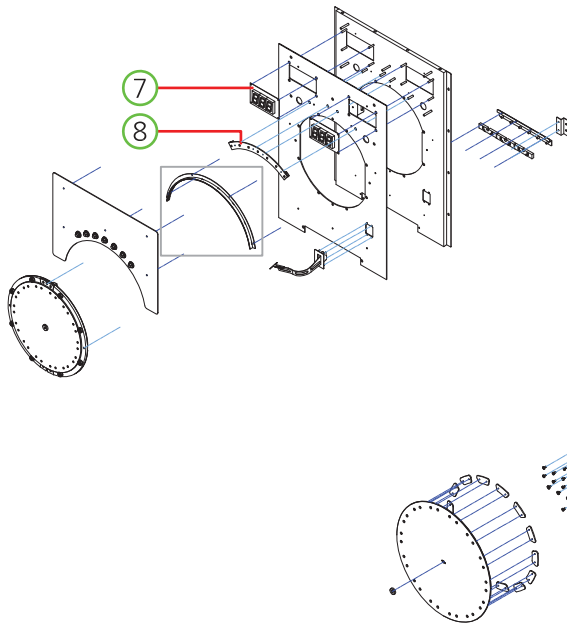

- MEDAL CIRCULATION PART

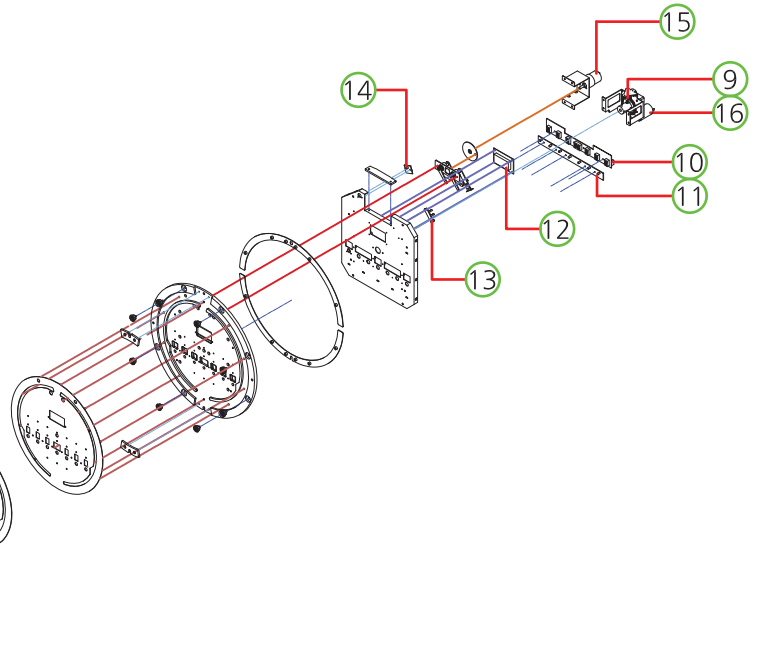

- BONUS FND PART
- SCORE BOARD PANEL PART
- MEDAL CIRCULATION PART
- PUSHER PANEL PART
- FRONT TABLE PART
- TICKET DOOR PART
- FRONT ROLLER PART
- COUNTER HOPPER PART
- SETUP PANEL PART

CARD DISPENSER PART

AC INPUT PART

SMPS POWER PART

MAIN BOARD PCB PART

ELEVATOR HOPPER PART

FRONT DOOR PART

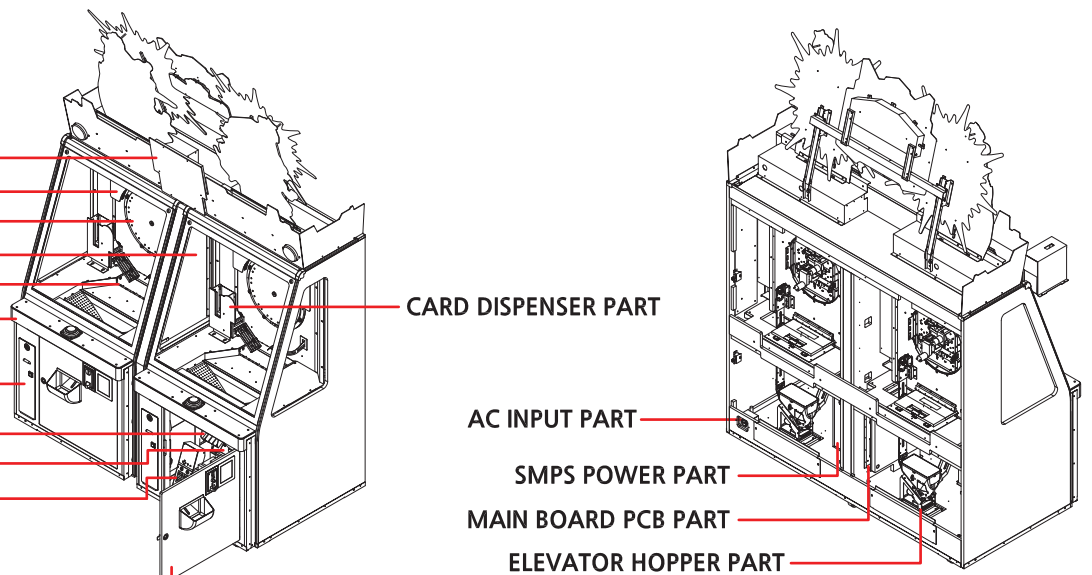

- CARD DISPENSER PART

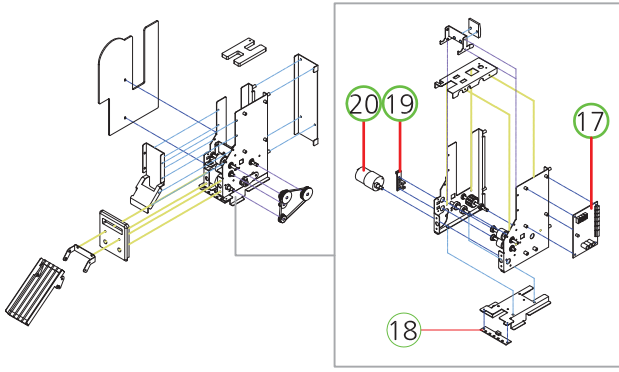

- COUNTER HOPPER PART

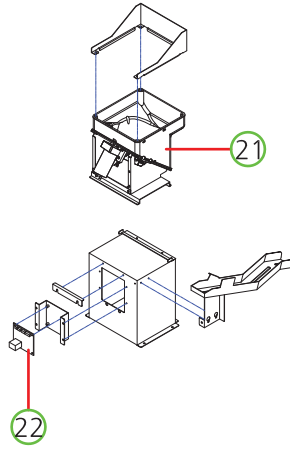

- TICKET DOOR PART

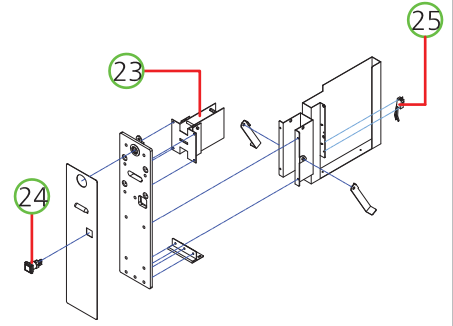

- FRONT DOOR PART

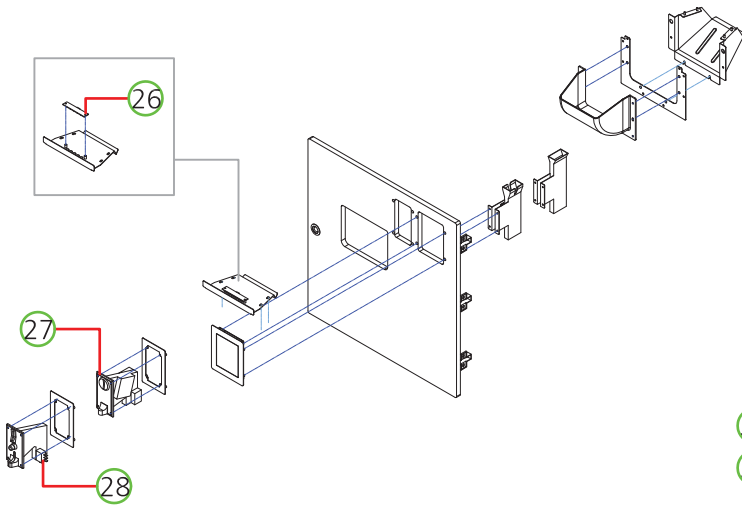

- AC INPUT PART

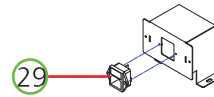

- MAIN BOARD PCB PART

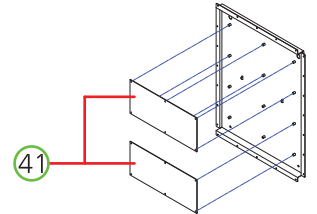

- SETUP PANEL PART

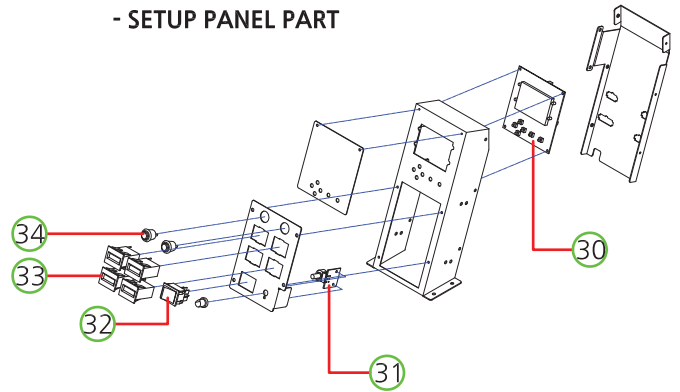

- SMPS POWER PART

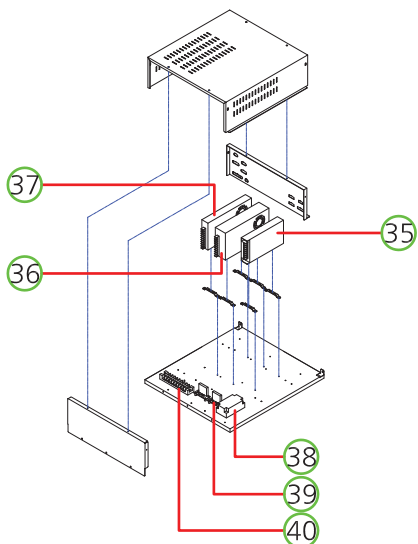

- FRONT TABLE PART

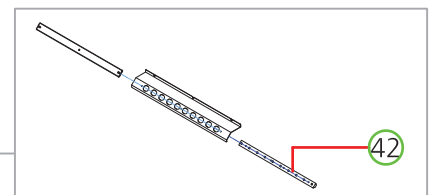
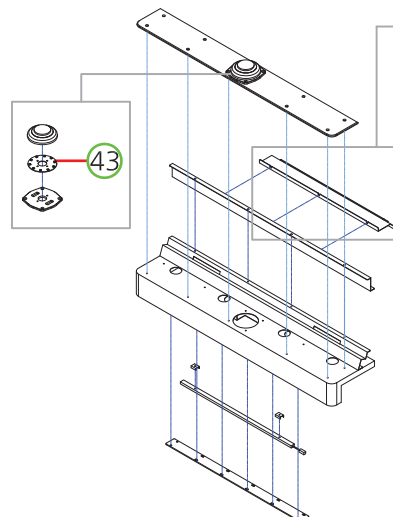

- ELEVATOR HOPPER PART

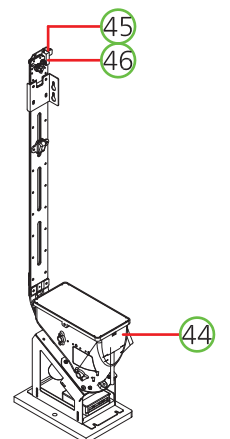

NO.	PIC	PART NAME	SPEC.	QTY	CODE NO.	WARRANTY	
						6 Month	One Year
①	○	JACKPOT LIGHTING PCB ASS'Y	-	3	ADC20PCB001		○
②	○	FND PCB ASS'Y	4870-5(STRAIGHT)	1	AFND0PCB033		○
③	○	PHOTO INT-1 ASS'Y	-	1	ACIROPCB011		○
④	○	AC MOTOR [120V]	K6IG6NU	1	MZZZ0MOT085	○	
		AC MOTOR [220V]	K6IG6NC	1	MZZZ0MOT095	○	
⑤	○	PHOTO INT-1 PCB ASS'Y	-	2	ACIROPCB011		○
⑥	○	MOTOR	KGV-0060 ND3657W1	1	MZZZ0MOT087	○	
⑦	○	BONUS FND PCB ASS'Y	FND-1817-3	2	ASBP0PCB003		○
⑧	○	WHEEL SPIN LED PCB ASS'Y	-	1	ADCC0PCB004		○
⑨	○	PHOTO INT1 (ANGLE) PCB ASS'Y	-	1	AZZZ0PCB103		○
⑩	○	MEDAL CIRCULATION FND PCB ASS'Y	-	1	ADCC0PCB009		○
⑪	○	MEDAL CIRCULATION CHECK-A PCB ASS'Y	-	1	ADCC0PCB006		○
⑫	○	FND PCB ASS'Y	2029-3	1	AFND0PCB028		○
⑬	○	PHOTO INT1 (ANGLE) PCB ASS'Y	-	1	AZZZ0PCB103		○
⑭	○	MEDAL CIRCULATION CHECK-B PCB ASS'Y	-	1	ADCC0PCB007		○
⑮	○	DC MOTOR	KGC-0060-ND3657U2_24V	1	MZZZ0MOT109	○	
⑯	○	DC MOTOR	KGE-0687-ND3448S1	1	MZZZ0MOT108	○	
⑰	○	CARD DISPENSOR I/O PCB ASS'Y	-	1	ASBP0PCB008		○
⑱	○	LED PCB ASS'Y	-	1	AMUM0PCB005		○
⑲	○	PHOTO INT1 (ANGLE) PCB ASS'Y	-	1	AZZZ0PCB103		○
⑳	○	MOTOR	KGC-040-3429C	1	MZZZ0MOT089	○	
㉑	○	HOPPER MACHINE	AM-CH2-1 DC	1	AZZZ0HOP035	○	
㉒	○	L6205 V2 HOPPER PCB ASS'Y	-	1	AZZZ0PCB172		○
㉓	○	TICKET DISPENSER	CLE CL-002Q_270	1	MZZZ0TID010		
㉔	○	BUTTON	AM1PB-26SH R12D	1	MMUM0BUT002		
㉕	○	MICRO SWITCH	GSM-V1631A1 [ CEC ]	1	MELE0MIC022		
㉖	○	LED PCB ASS'Y	-	1	AMUM0PCB005		○
㉗	○	COIN SELECTOR [ INT ]	TW-389	1	MZZZ0COS052		
㉘	○	COIN SELECTOR [ CEC ]	HS-03CS+SWITCH	1	MZZZ0COS028		
㉙	○	AC INPUT	DAC-13H	1	MELE0SWI015		
㉚	○	SETUP LCD PCB ASS'Y	-	1	AZZZ0PCB113		○
㉛	○	VOLUME PCB ASS'Y	1 VOLUME	1	AHM20PCB016		○
㉜	○	ROCKER SWITCH	R59KDF	1	MELE0SWI021		
㉝	○	COUNTER	AMMC-712(OA127CL)	4	MZZZ0COU002		
㉞	○	PUSH SWITCH	HS-412R	2	MELE0PUS006		
㉟	○	POWER SMPS	RSP-100-5	1	MELE0SMP104		○
㊱	○	POWER SMPS	SP-320-24	1	MELE0SMP089		○
㊲	○	POWER SMPS	RSP-320-12	1	MELE0SMP109		○
㊳	○	NOISE FILTER	RNS-2010	1	MELE0NOI009		
㊴	○	TERMINAL BLOCK	250V 10P UL_CE	2	MELE0TEB003		
㊵	○	SSR PCB ASS'Y	-	1	AENS0PCB001		○
㊶	○	MAIN PCB ASS'Y	WITH CPU_SOUND	1	ADCC0ASS015		○
㊷	○	BILLBOARD LED 10 PCB ASS'Y	-	1	ASBP0PCB005		○
㊸	○	BUTTON_LED PCB ASS'Y	-	1	ASHS0PCB002		○
㊹	○	ELEVATOR HOPPER BODY ASS'Y	-	1	AZZZ0ELH020	○	
㊺	○	ELEVATOR HOPPER TOP	-	1	AZZZ0ELH002	○	
㊻	○	ELEVATOR SENSOR ASS'Y	-	1	AZZZ0PCB173		○

1	2	3	4	5	6
ADC20PCB001	AFND0PCB033	ACIR0PCB011	MZZZ0MOT085	ACIR0PCB011	MZZZ0MOT087





7	8	9	10	11	12
ASBP0PCB003	ADCC0PCB004	AZZZ0PCB103	ADCC0PCB009	ADCC0PCB006	AFND0PCB028

13	14	15	16	17	18
AZZZ0PCB103	ADCC0PCB007	MZZZ0MOT109	MZZZ0MOT108	ASBP0PCB008	AMUM0PCB005

19	20	21	22	23	24
AZZZ0PCB103	MZZZ0MOT089	AZZZ0HOP035	AZZZ0PCB172	MZZZ0TID010	MMUM0BUT002

25	26	27	28	29	30
MELE0MIC022	AMUM0PCB005	MZZZ0COS045	MZZZ0COS028	MELE0SWI015	AZZZ0PCB113

31	32	33	34	35	36
AHM20PCB016	MELE0SWI021	MZZZ0COU002	MELE0PUS006	MELE0SMP104	MELE0SMP089

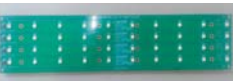
37	38	39	40	41	42
					
MELE0SMP109	MELE0NOI009	MELE0TEB003	AENS0PCB001	ADCC0ASS015	ASBP0PCB005

43	44	45	46
			
ASHS0PCB002	AZZZ0ELH020	AZZZ0ELH002	AZZZ0PCB173

# POWER BOX ASS'Y

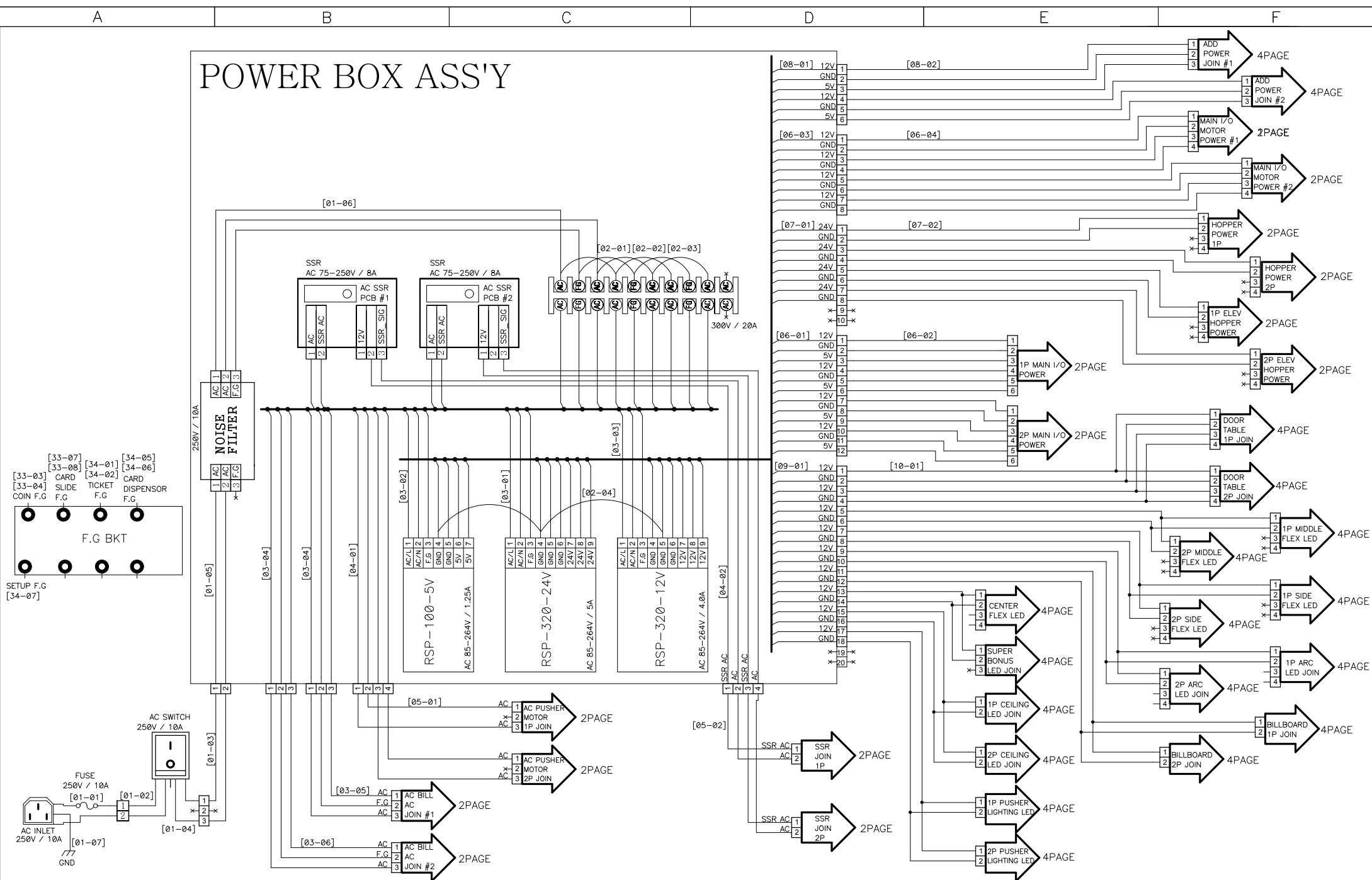

REPRODUCTION, DISTRIBUTION AND UTILIZATION OF THIS DOCUMENT AS WELL AS COMMUNICATION OF ITS CONTENTS TO OTHERS WITHOUT EXPRESS AUTHORIZATION PROHIBITED. OFFENDERS WILL BE HELD LIABLE FOR THE PAYMENT OF DAMAGES. ALL RIGHT RESERVED. COPYRIGHT (c) ANDAMIRO

(복제, 배포 및 사용은 물론, 명시적 허가 없이는 타인에게 내용을 전달할 수 없으며 위반자는 손해 배상 책임을 집니다.)

DEPARTMENT	DRAWN BY	CHECKED BY	APPROVED BY	ITEM
H/W	H.B.KIM			DC SUPER HEROES 2P
				PAGE 1 PAGE
				DATE 2018.05.10





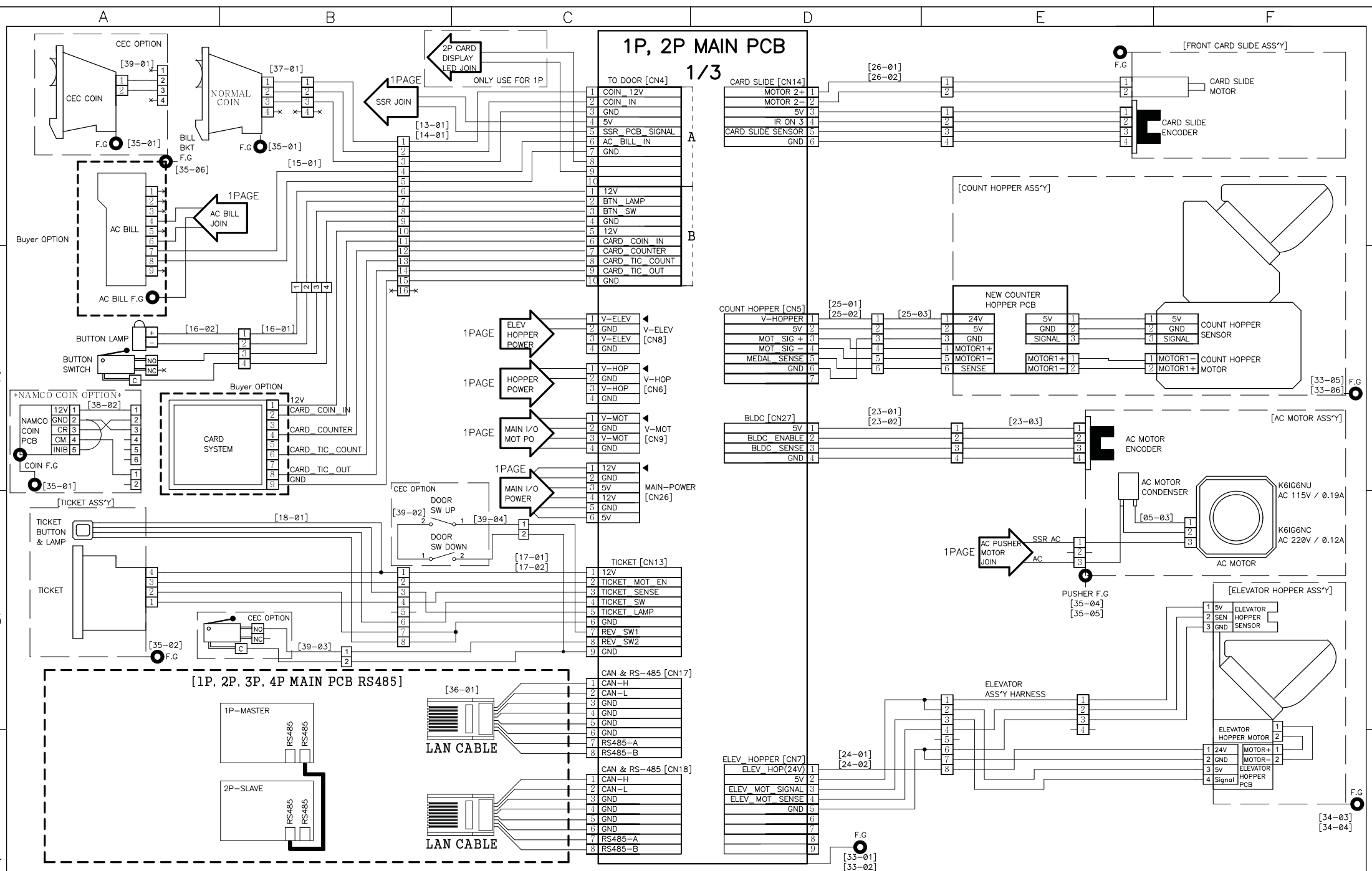

REPRODUCTION, DISTRIBUTION AND UTILIZATION OF THIS DOCUMENT AS WELL AS COMMUNICATION OF ITS CONTENTS TO OTHERS WITHOUT EXPRESS AUTHORIZATION PROHIBITED. OFFENDERS WILL BE HELD LIABLE FOR THE PAYMENT OF DAMAGES. ALL RIGHT RESERVED. COPYRIGHT (c) ANDAMIRO

(복제, 배포 및 사용은 물론, 명시적 허가 없이는 라인에게 내용을 전달할 수 없으며 위반자는 손해 배상 책임을 집니다.)

DEPARTMENT	DRAWN BY	CHECKED BY	APPROVED BY	ITEM	DC SUPER HEROES 2P
H/W	H.B.KIM			PAGE	2 PAGE [1P, 2P Common]
				DATE	2018.05.10



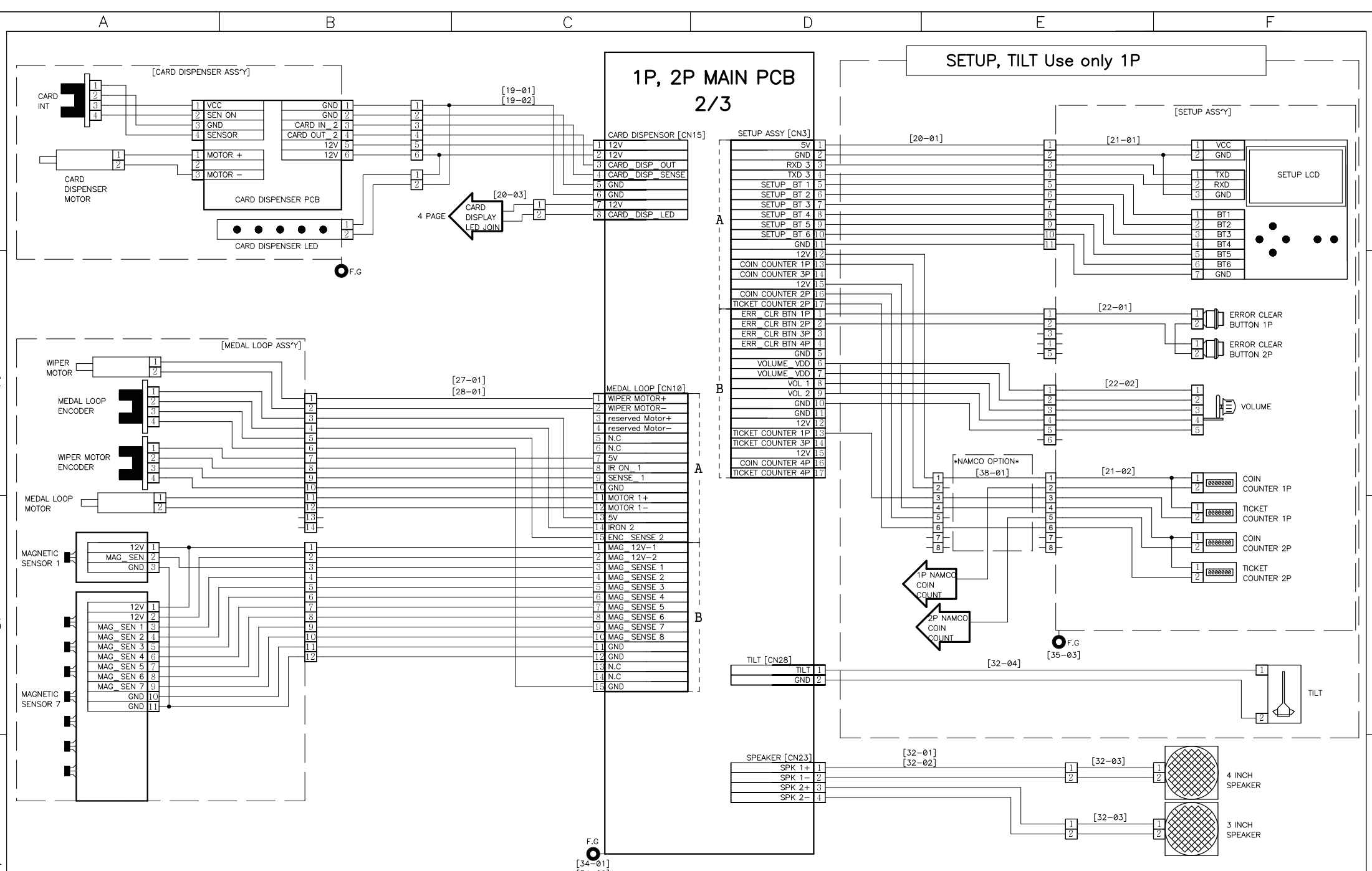

REPRODUCTION, DISTRIBUTION AND UTILIZATION OF THIS DOCUMENT AS WELL AS COMMUNICATION OF ITS CONTENTS TO OTHERS WITHOUT EXPRESS AUTHORIZATION PROHIBITED. OFFENDERS WILL BE HELD LIABLE FOR THE PAYMENT OF DAMAGES. ALL RIGHT RESERVED. COPYRIGHT (c) ANDAMIRO

(복제, 배포 및 사용은 물론, 명시적 허가 없이는 라이에게 내용을 전달할 수 없으며 위반자는 손해 배상 책임을 집니다.)

DEPARTMENT	DRAWN BY	CHECKED BY	APPROVED BY	ITEM
H/W	H.B.KIM			DC SUPER HEROES 2P
				PAGE 3 PAGE [1P, 2P Common]
				DATE 2018.05.10





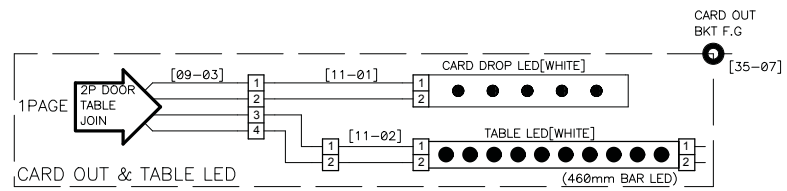
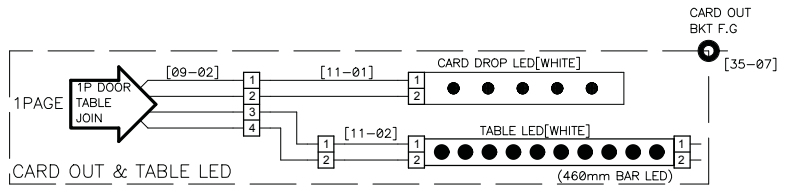
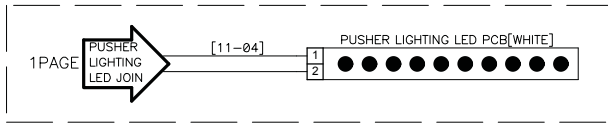
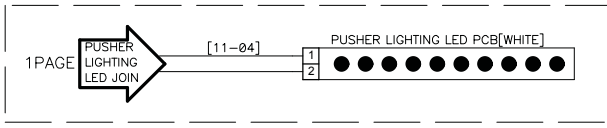
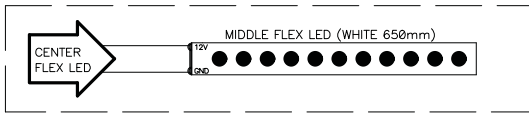
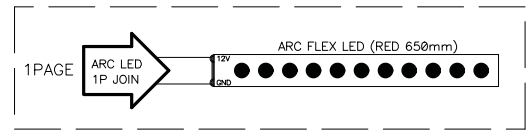
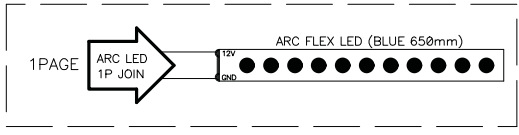
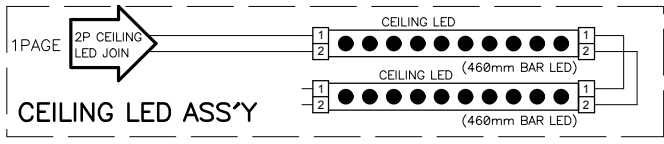
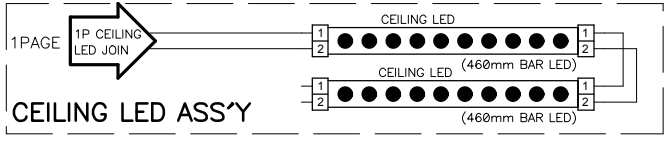
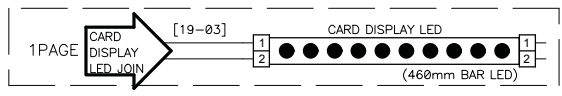
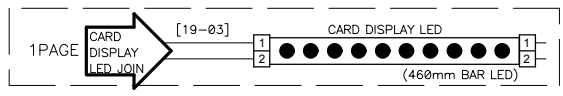
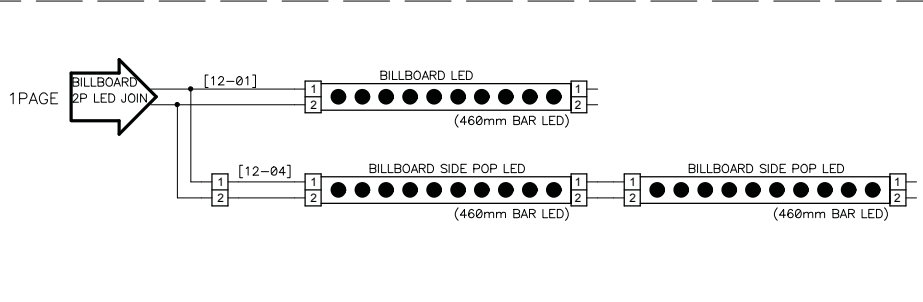
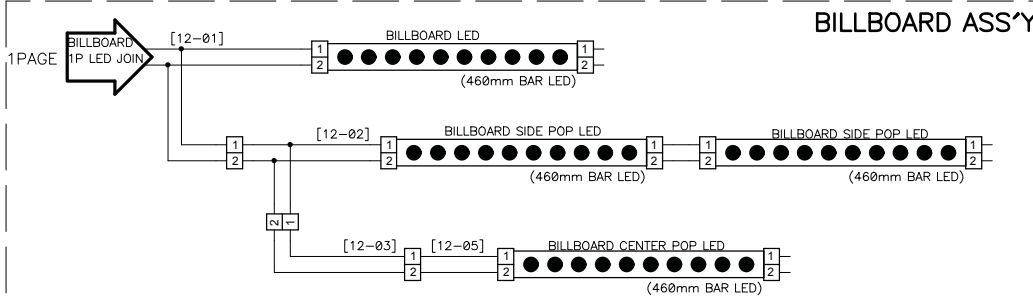

REPRODUCTION, DISTRIBUTION AND UTILIZATION OF THIS DOCUMENT AS WELL AS COMMUNICATION OF ITS CONTENTS TO OTHERS WITHOUT EXPRESS AUTHORIZATION PROHIBITED. OFFENDERS WILL BE HELD LIABLE FOR THE PAYMENT OF DAMAGES. ALL RIGHT RESERVED. COPYRIGHT (c) ANDAMIRO

(복제, 배포 및 사용은 물론, 명시적 허가 없이는 라인에게 내용을 전달할 수 없으며 위반자는 손해 배상 책임을 집니다.)

DEPARTMENT	DRAWN BY	CHECKED BY	APPROVED BY	ITEM	DC SUPER HEROES 2P
H/W	H.B.KIM			PAGE	5 PAGE
	ANDAMIRO			DATE	2018.05.10



## **ANDAMIRO WARRANTY POLICY**



Andamiro warrants to the original purchaser that all of its products will be free from defects in material and workmanship.

**Andamiro warrants the parts from date of shipment as follows.**

- **One Year Limited Warranty : Electronic Boards**
- **6 Month Limited Warranty : Moving Parts**

For any key components within the warranty period, Andamiro will repair or replace defective components free of charge.

When placing a warranty request, the customer is requested to furnish the following information:

1. Name of the game.
2. Serial Number of the game.
3. A Detailed Description of the defect/s experienced.

This warranty does not apply to the defects caused due to misuse or abuse of the product.

Any alterations made to game or game parts will void this warranty.

For warranty details on our product range please visit our website, [www.andamiro.com](http://www.andamiro.com).

ANDAMIRO CO., LTD.  
[www.andamiro.com](http://www.andamiro.com)



Please complete the following request form to place a warranty request and send it to ANDAMIRO Korea either by fax (Fax No: +82-31-908-7548) or by e-mail. The e-mail address of the person in charge of each region is shown in our web-site, [www.andamiro.com](http://www.andamiro.com)

For the on-line request, please visit our web-site, [www.andamiro.com](http://www.andamiro.com) and click "Customer Service" and then click "Contact Us" in which you shall find the e-mail address of the person in charge of each region.

**1. Company Name :** \_\_\_\_\_

**2. Mailing Address :** \_\_\_\_\_

\_\_\_\_\_

**3. E-Mail Address :** \_\_\_\_\_

**4. Phone No :** \_\_\_\_\_

**5. Name of the person in charge :** \_\_\_\_\_

**6. Description of the product defects**

6-1 ) Name of the Game : \_\_\_\_\_

6-2 ) Serial No : \_\_\_\_\_

6-3 ) Date of Purchase : \_\_\_\_\_

6-4 ) Detailed description of the product defects.

\_\_\_\_\_

\_\_\_\_\_

\_\_\_\_\_

Remarks: If possible, please provide us with related photos and videos which will be greatly appreciated to verify the cause of the problem.



---

**ANDAMIRO CO., LTD.**

TEL : 82-31-909-2123~5

**[ADDRESS OFFICE]** 704-1 Techno Town, 138, Ilsan-ro, Ilsandong-gu, Goyang-si,  
Gyeonggi-do, Republic of Korea 10442

**[FACTORY]** 72 Nochemgil, Ilsan-donggu Goyang-si, Gyonggi-do, 410-834 korea

**USA BRANCH**

ANDAMIRO USA CORP.

TEL : 1-310-767-5800

**[ADDRESS]** 17230 S. Main Street Gardena, California 90248 U.S.A.

Homepage <http://www.andamiro.com/>