

**BougeRV**

# User Manual

## Buck-Boost Mppt Solar Charge Controller

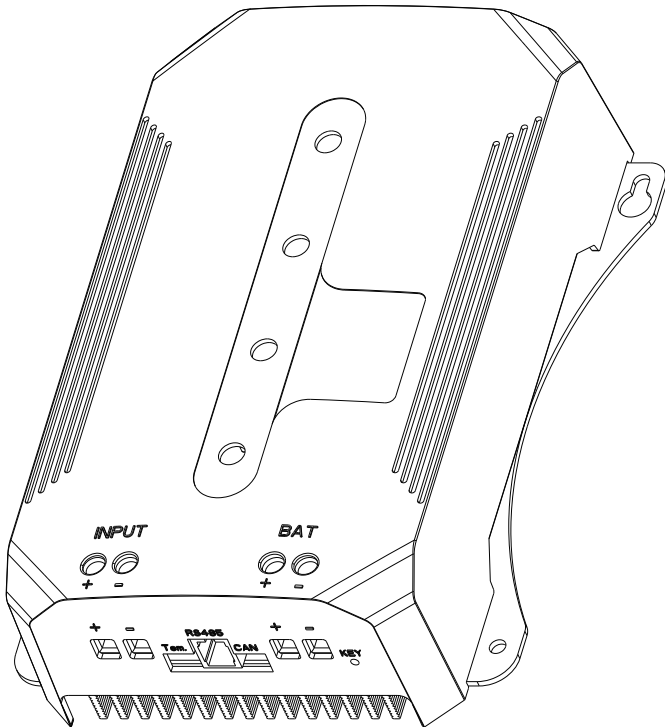

# Content

1. Safety Instructions -----	1
2. Technical After Services-----	2
3. Identification Of Parts-----	3
4. Mounting Instruction-----	4
5.Wiring Instructions-----	5
6. Solar Panel Power Mode-----	6
7. DC Input Source Power Mode-----	7
8. Bluetooth Module-----	8
9. LED Indicator Light Chart-----	9
10. RS485 Connection Diagram (RJ12)-----	10
11. Error Code-----	11
12. Base Specification-----	12
13. Battery Charge Parameter-----	13
14. Charging-----	14
15. Product Dimensions-----	16



# 1.Safety Instructions



Please follow the safety instructions for operation, the damage caused by not following the safety instructions shall be borne by the individual.



## **Please save these instructions**

If you need to use the PDF version of the manual, you can contact us: [service@bougerv.com](mailto:service@bougerv.com).

### **1-1.General Safety Information**

- 1.Read all of the instructions and cautions in the manual before installation.
- 2.There are no repairable parts for this controller,do not disassemble or attempt to repair the controller.
- 3.Keep the controller from the water.
- 4.Make sure all connections with controller are tight.
- 5.Please read the product installation steps to ensure all connections are correct.

### **1-2.Charge Controller Safety**

- 1.NEVER connect the solar panel array to the controller without a battery. The battery must be connected first.
- 2.Ensure input voltage does not exceed the Maximum PV input voltage to prevent permanent damage.
- 3.Ensure that the output current of the solar panel does not exceed the rated charging current of the controller.

### **1-3.Battery Safety**

1. Do NOT let the positive (+) and negative (-) terminals of the battery touch each other.
2. Explosive battery gases may be present while charging. Be certain there is enough ventilation to release the gases.
3. Be careful when working with large lead-acid batteries. Wear goggles and have fresh water available in case there is contact with the battery acid.
4. Over-charging and excessive gas precipitation may damage the battery plates and activate material shedding on them. Too high of an equalizing charge or too long of one may cause damage. Please carefully review the specific requirements of the battery used in the system.

## 2. Technical After Services

BougeRV provides 1-on-1 Solar Solution and 18 months warranty service.

If you have any questions during use, please feel free to contact us:



**www.bougerv.com**



**service@bougerv.com (Amazon US/CA)**



**support@bougerv.com (BougeRV Website)**



**1-408-656-8402**



Whatsapp

**1-669-232-7427**

If you could provide the following relevant information to our email (**service@bougerv.com**) before contacting us; we can provide you with technical support solutions faster.

(1)The connection method of the solar panels (series/parallel, quantity, voltage, power).

(2)The voltage and battery type of the battery.

(3)The pictures or videos of the controller: battery voltage, battery charging current, the output voltage of the solar panel.

### 3. Identification Of Parts

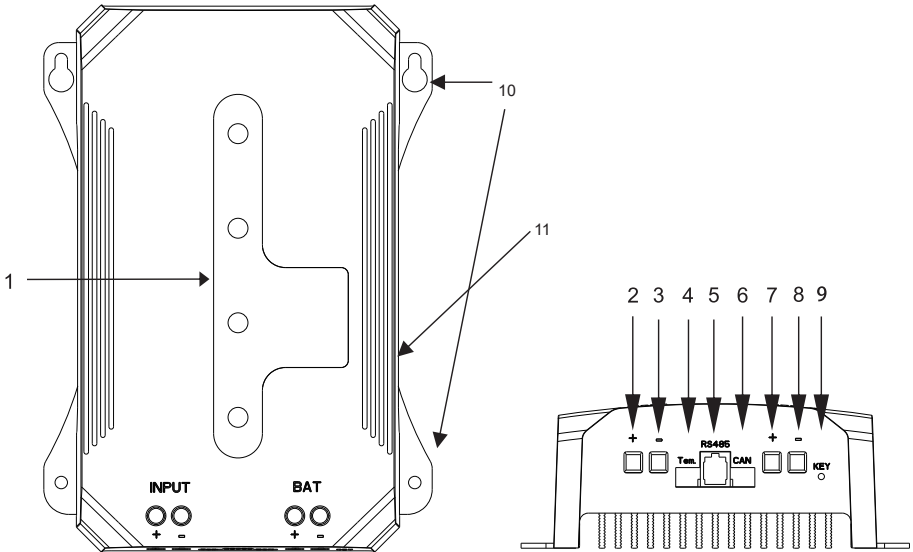

- 1. LED Indicator  
(Charge, In type, Battery type, Fault)
- 2. Input Positive Terminal
- 3. Input Negative Terminal
- 4. Temperature Sensor Terminal
- 5. RS485 Communication Port
- 6. CAN Communication Port

- 7. Battery Positive Terminal
- 8. Battery Negative Terminal
- 9. Pressing Keys (Flush Mount)
- 10. Installation Mounting Holes
- 11. Grounding Screws

## 4. Mounting Instruction

1. The positive and negative poles of the battery must be connected to the battery terminals of the controller first.
2. Finally, connect the positive and negative poles of the solar panel to the input terminals of the controller.

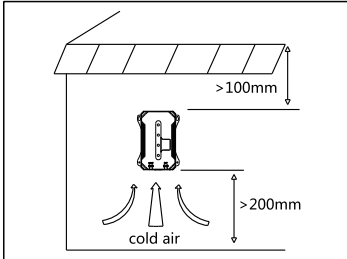

### Step1: site selection

Installation environment requirements: dry, ventilated, with sufficient air circulation range up and down.

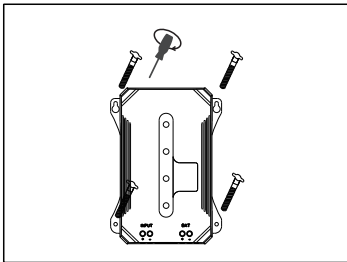

### Step2: fix

In the first step of site selection, fix the machine with screws according to the top\_x005f\_down principle.

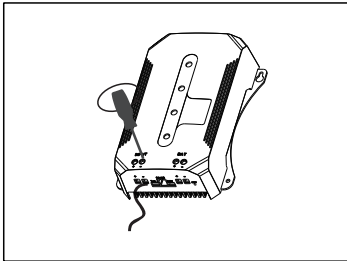

### Step3: wiring

Prepare the wires, strip the ends, and loosen the screws counterclockwise. Insert the wire ends and tighten the screws.

#### Note:

During the wiring process, the attached terminal lugs can be used for connection. After stripping the wire, put it into the terminal lugs and squeeze it with a crimping pliers.

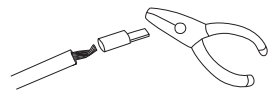

## 5.Wiring Instructions

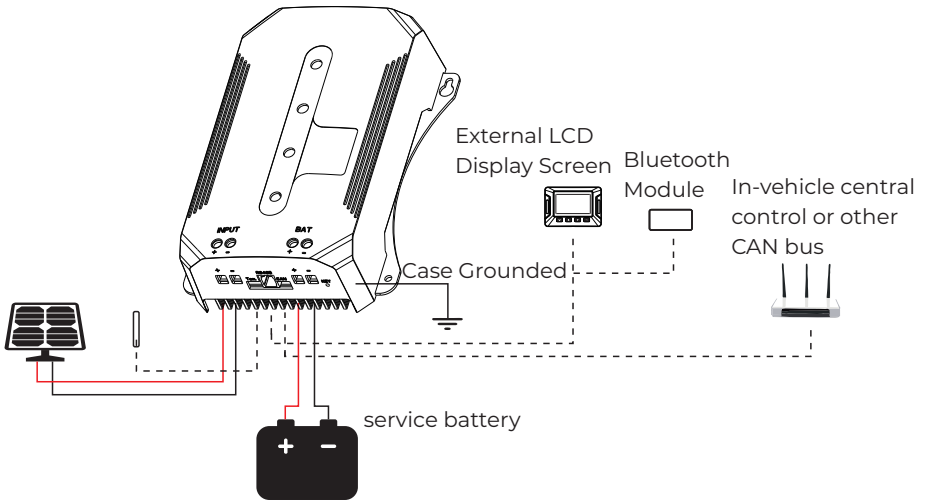

**Step 1:** Connect the battery, it is recommended to select the appropriate .

**Step 2:** Connect the solar panel or other DC input source.

Note: When connecting the wire, first use a screwdriver to loosen the terminal counterclockwise, insert the prepared wire, and tighten it clockwise again.

## 6.Solar Panel Power Mode

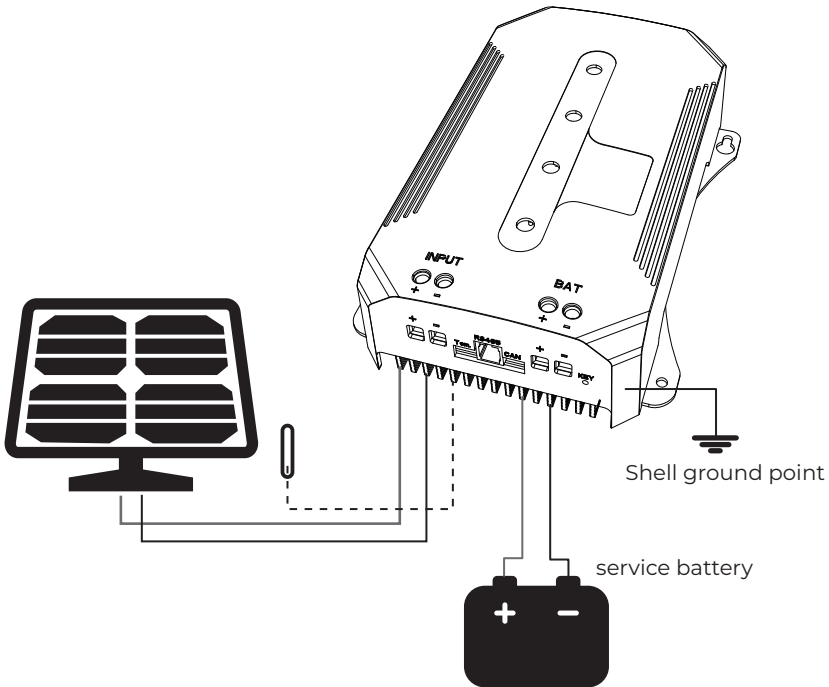

1. When the voltage of the solar panel exceeds 12V, the controller will engage in MPPT tracking and automatically initiate a step-up or step-down process to charge the battery; when the voltage of the solar panel drops below 9V, charging will be stopped.
2. When the PV input voltage exceeds 148V, the controller will stop working, the input voltage returns to 145V, the controller will resume functioning.



## 7. DC Input Source Power Mode

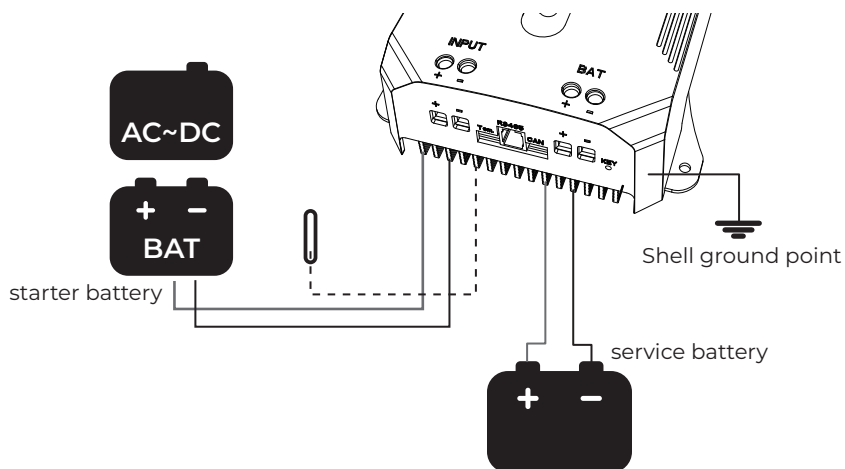

**Battery:** It can be understood as a constant current source with infinite current. Therefore, when used as an input source, the controller is in constant voltage and current limit charging mode. However, a minimum voltage needs to be set to prevent the input battery from being over-discharged and damaging the battery.

**Charging start voltage:**  $13.6V * \text{battery voltage}/12V$ ;

**Charging stop voltage:**  $11.7V * \text{battery voltage}/12V$ ;

For example, if the input is set to 48V,

**Charging start voltage:**  $13.6V * 48/12V = 54.4V$ ;

**Charging stop voltage:**  $11.7V * 48/12V = 46.8V$ ;

**Switching power supply:** the ordinary switching power supply is a constant voltage source, so it can be treated as a PV when charging.

	BAT_12	BAT_24	BAT_48	BAT_60	BAT_72	USE(adj)
Minimum start-up charging voltage	13.6V	27.2V	54.4V	68.0V	81.6V	12.6V(def)
Stop charging voltage	11.7V	23.4V	46.8V	58.5V	70.2V	9.0V(def)
Input overvoltage	110V					
Input overvoltage recovery voltage	105V					

## 8. Bluetooth Module

Built-in Bluetooth communication function can monitor the operation data, fault status and adjust the operation parameters of the controller in real time through mobile APP.

### Download

1. Scan the QR code on the right to download the application



2. Search for "**ChargePro 2.0**" in the APP Store (for IOS devices) or Google Play (for Android devices).

### Precautions For Using APP

1. The Bluetooth function of the mobile phone is available and turned on.
2. The GPS function is available and turned on in your phone.
3. Android firmware 5.0 and above, or IOS firmware 9.0 and above.

## 9. LED Indicator Light Chart

Built-in Bluetooth communication function can monitor the operation data, fault status and adjust the operation parameters of the controller in real time through mobile APP.

### 9.1 CHG Indication Mode

Indicator color	Indicator status	Input charging status
green	off	Not charging
green	steady on	MPPT or limited power charging
green	slow flash(on for 2 seconds)	Equalized/Boost/Float charging
green	fast flash(on for 0.2 seconds)	Input over-voltage

### 9.2 Input Type Indication Mode

Indicator color	Indicator status	Input charging status
green	steady on	Solar panel output
blue	steady on	DC input source

### 9.3 BAT Indication Mode

Indicator color	Indicator status	battery status
white	steady on	SEL/USE
green	steady on	GEL
blue	steady on	FLD
cyan	steady on	LFP 12V
purple	steady on	LFP 24V
yellow	steady on	LFP 48V
off	no battery connected	

## 9.4 FAULT Indication Mode

Indicator color	Indicator status	System working status
red	off	the system is normal
red	steady on	system fault or warning

## 10.RS485 Connection Diagram (RJ12)

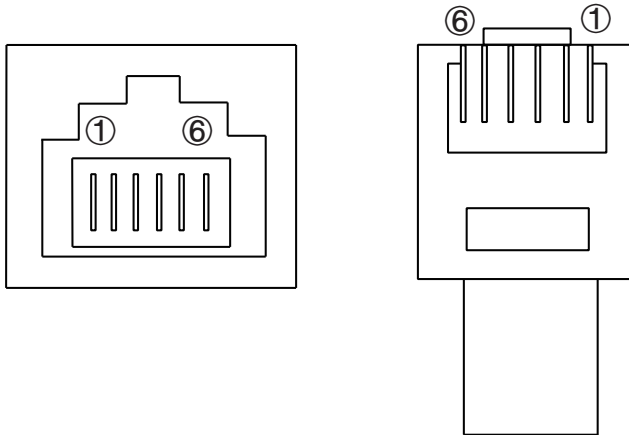

RS485 PIN (RJ12)					
PIN-1	PIN-2	PIN-3	PIN-4	PIN-5	PIN-6
VDD	VDD	GND	GND	D-	D+

\* Support 3.3V power supply, the supply current is 20mA

## 11. Error Code

The error code of the controller can be displayed through an external LCD display screen (optional accessory), and the corresponding text description can be displayed in the mobile APP.

<b>Cause of failure</b>	<b>Solution</b>
No Error	No action needed.
Battery over-discharge	Note that the battery voltage is too low. Until the battery is recharged to the recovery voltage.
Battery over-voltage	The battery voltage has exceeded the controller limit. Check that if the battery voltage is compatible with the controller.
Overheating	The controller exceeds the temperature limit, turns off the charging. Ensure that the controller is placed in a well ventilated, cool, and dry place.
Environmental Over-temperature	The ambient temperature sampled by the external temperature probe is too high.
Solar Over-voltage	The solar array voltage exceeds the rated input voltage of the controller. Decrease the voltage of solar panels connected to the controller.
Solar Reverse Polarity	The solar panel connection wires and the controller polarity connection are reversed. Disconnect and reconnect to the correct polarity.
Battery Reverse Polarity	Battery connection wires and the controller polarity connection are reversed. Disconnect and reconnect to the correct polarity.

## 12.Base Specification

Model	BV4820CUK	BV4840CUK
System voltage	12V/24V/36V/48V	
Rated charging current	20A	40A
Battery Type	SEL/GEL/FLD/LI/USE,SEL as default	
Maximum input of PV system	300W/12V ; 600W/24V; 900W/36V ; 1200W/48V	600W/12V ; 1200W/24V; 1800W/36V ; 2400W/48V
Maximum PV input voltage	150V (148V protection, 145V recovery)	
MPPT tracking efficiency	>99%	
Charging conversion efficiency	>95%	
Protection function	PV overvoltage protection, PV reverse connection protection, PV short circuit protection, night reverse charging protection, input power limit protection, over-temperature protection, battery over-voltage protection, battery reverse connection protection.	
No-load Loss	2mA(12V), 10mA(24V), 8mA(36V), 6mA(48V)	
Grounding type	Grounding of common negative electrode	
Operating ambient temperature range	-31°F~113°F (-35°C~45°C)	
Protection grade	IP34	
Communication Port	RS485 (RJ12)+Inbuilt Bluetooth	
Controller Dimension (mm)	220*159*58	220*159*80

## 12.Base Specification

Battery Type Setting Voltage	Sealed Lead-Acid SEL	Gel lead-acid battery GEL	Flooded lead -acid battery FLD	Lithium battery LI	Custom battery USE
<b>Equalizing voltage</b> <sup>①</sup>	14.6V	/	14.8V	/	Default: GEL
<b>Boost voltage</b> <sup>①</sup>	14.4V	14.2V	14.6V	14.6V	Default: GEL
<b>Float charge voltage</b> <sup>①</sup>	13.8V	13.8V	13.8V	/	Default: GEL
<b>Boost charging reconnect voltage</b> <sup>①</sup>	13.2V	13.2V	13.2V	/	Default: GEL
<b>Equalizing charging interval</b>	30 days	/	30 days	/	Default: GEL
<b>Equalizing charging duration</b>	120 min	/	120 min	/	Default: GEL
<b>Boost charging duration</b>	120 min	120 min	120 min	/	Default: GEL
<b>Temperature compensation factor mV/°C/2V</b>	-3	-3	-3	/	Default: -3

Note:

① The above values are the parameters at 25°C/12V;

if it is the system of 24V, relevant voltage points shall be automatically multiplied by 2.

if it is the system of 36V, relevant voltage points shall be automatically multiplied by 3.

if it is the system of 48V, relevant voltage points shall be automatically multiplied by 4.

# 14.Charging

## 14.1 Charging of lead-acid battery

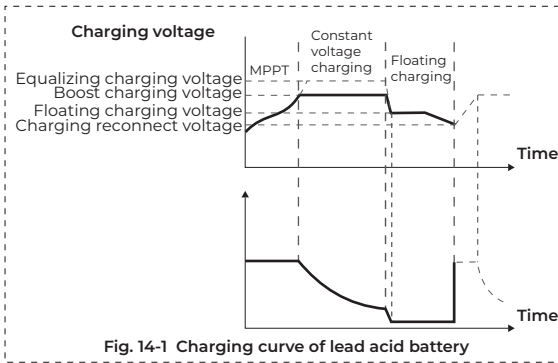

Fig. 14-1 Charging curve of lead acid battery

Select such battery types as SLD/FLD/GEL/USE, and select the appropriate system voltage.

As shown in Fig. 14-1, the charging stages of lead-acid battery are:

MPPT charging, constant voltage charging (equalizing/boost/floating charging), and current-limiting charging.

The constant voltage charging is divided into three stages: equalizing charging, boost charging and floating charging

[MPPT charging] When the battery voltage has not reached the target constant voltage value, the controller will perform MPPT charging. When the battery voltage reaches the constant voltage value, it will automatically exit MPPT charging and switch to constant voltage charging (equalizing/boosting/floating charging).

[Equalizing charging] Regular equalizing charging is good for some batteries. Equalizing charging is mainly to make the charging voltage of battery higher than the standard supplementary voltage, besides, it can vaporize the battery electrolyte to balance the battery voltage and complete relevant chemical reaction. Equalizing charging and boosting charging are not repeated during one full charging to avoid excessive gas evolution or overheating of the battery.

Notes:

- 1) Since the equalizing charging of flooded lead-acid battery produces explosive gas, the battery compartment must be well ventilated.
- 2) Although the equalizing charging elevates the battery voltage, it may damage the level of sensitive DC loads, therefore, it is necessary to verify that the allowable input voltage of all loads in the system is greater than the set battery voltage value in equalizing charging.



3) Excessive charging and excessive gas evolution may damage the battery plate and cause the active substances on the battery plate to fall off. Besides, excessive high equalizing charging voltage or excessive long equalizing charging duration may damage the battery. Please set relevant parameters according to the specifications of the battery used in the system.

[Boost charging] The duration of boost charging is 2 h (default). When the duration reaches the set value, the system will switch to floating charging.

[Floating charging] Floating charging is the last constant voltage charging stage in the charging cycle of lead-acid battery. The controller keeps the charging voltage constant at the floating charging voltage. At this stage, the battery is charged with a very weak current to ensure that the battery is in full-charging. When the battery voltage is as low as the reconnect voltage of boost charging, the system will exit the floating charging stage and re-enter the next charging cycle.

## 14.2 Charging of lithium battery

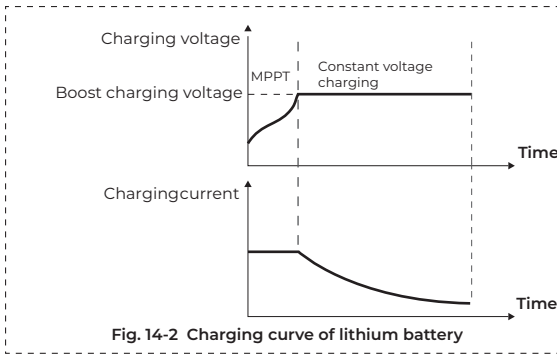

Select such battery types as LI, and select the system voltage from 12V/24V. As shown in Fig. 14-2, the charging stages of lithium battery are: MPPT charging/-boost charging/current-limiting charging.

[MPPT charging] When the battery voltage does not reach the target constant voltage value, the controller conducts MPPT charging to charge the battery with maximum solar power, when reaches, it automatically switches to boost charging.

[Boost charging] In the boost charging stage of lithium battery, when the battery voltage is lower than the boost charging voltage, the system conducts MPPT charging or current-limiting charging, when reaches, it switches to boost charging.

# 15.Product Dimensions

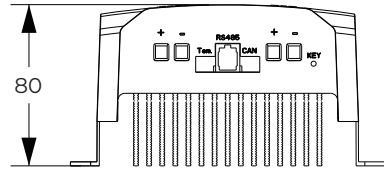
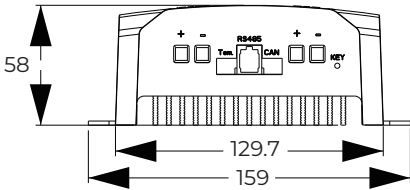
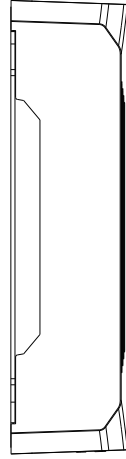
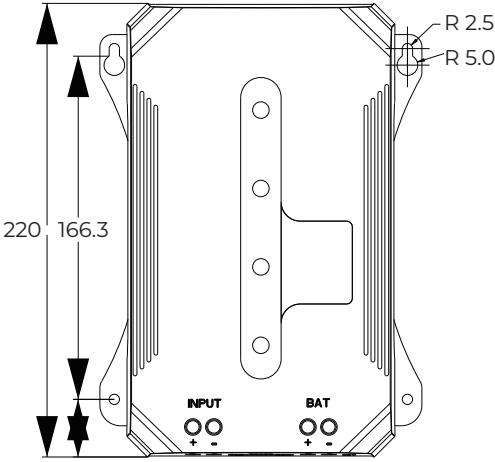

Model : BV4820CUK  
 Product Dimension : 220\*159\*58mm  
 Installation Area Dimension : 166.3\*142mm  
 Installation Hole Size : 5 & 2.5mm  
 Connection Socket Size : 7.5\*8.5mm

Model : BV4840CUK  
 Product Dimension : 220\*159\*80mm  
 Installation Area Dimension : 166.3\*142mm  
 Installation Hole Size : 5 & 2.5mm  
 Connection Socket Size : 7.5\*8.5mm



# BougeRV

Make the journey



[www.bougerv.com](http://www.bougerv.com)



[service@bougerv.com](mailto:service@bougerv.com) (Amazon US/CA)



[support@bougerv.com](mailto:support@bougerv.com) (BougeRV Website)



1-408-656-8402



Whatsapp

1-669-232-7427