

# Operating and Assembly Instructions

## Absolute Encoder

### AMS 40

### ASS 40

**Read the Operating and Assembly Instructions prior to assembly, starting installation and handling!  
Keep for future reference!**

**Trademark**

Brand names and product names are trademarks or registered trademarks of their respective owner. Protected trademarks bearing a <sup>TM</sup> or ® symbol are not always depicted as such in the manual. However, the statutory rights of the respective owners remain unaffected.

**Manufacturer / publisher**

Johannes Hübner  
Fabrik elektrischer Maschinen GmbH  
Siemensstr. 7  
35394 Giessen  
Germany  
Phone: +49 641 7969 0  
Fax: +49 641 73645  
Internet: [www.huebner-giessen.com](http://www.huebner-giessen.com)  
E-Mail: [info@huebner-giessen.com](mailto:info@huebner-giessen.com)

The manual has been drawn up with the utmost care and attention. Nevertheless, we cannot exclude the possibility of errors in form and content. It is strictly forbidden to reproduce this publication or parts of this publication in any form or by any means without the prior written permission of Johannes Hübner Fabrik elektrischer Maschinen GmbH.  
Subject to errors and changes due to technical improvements.

Copyright © Johannes Hübner Fabrik elektrischer Maschinen GmbH  
All rights reserved.

## Directory

<b>1 General</b> .....	<b>5</b>
1.1 Information about the Operating and Assembly Instructions .....	5
1.2 Scope of delivery .....	5
1.3 Explanation of symbols .....	5
1.4 Disclaimer .....	6
1.5 Copyright .....	6
1.6 Guarantee terms .....	6
1.7 Customer service .....	6
<b>2 Safety</b> .....	<b>6</b>
2.1 Responsibility of the owner .....	6
2.2 Intended use .....	6
2.3 Non - intended use .....	7
2.4 Personnel .....	7
2.5 Personal protective equipment .....	8
2.6 Special dangers .....	8
2.6.1 Electrical current .....	8
2.6.2 Rotating shafts / Hot surfaces .....	8
2.6.3 Safeguarding against restart .....	8
<b>3 Technical Data</b> .....	<b>9</b>
3.1 Type plate .....	9
3.2 Electrical and mechanical data .....	10
3.3 Type key .....	11
<b>4 Transport, packaging and storage</b> .....	<b>12</b>
4.1 Safety instructions for transport .....	12
4.2 Incoming goods inspection .....	12
4.3 Packaging / disposal .....	12
4.4 Storage of packages (devices) .....	12
<b>5 Installation and commissioning</b> .....	<b>13</b>
5.1 Safety instructions .....	13
5.2 Technical information .....	13
5.3 Required tools .....	13
5.4 Mounting preparations .....	14
5.5 Mounting B5 type (flange) .....	14
5.6 Mounting B35 type (flange and foot) .....	16
5.7 Mounting tolerances for Construction Type B5 and B35 .....	17
5.8 Electrical connection and start up .....	18
5.8.1 Preparing cables .....	18
5.8.2 Electrical connection .....	18
<b>6 Dismantling</b> .....	<b>19</b>

---

6.1	Safety instructions.....	19
6.2	Dismantling the absolute encoder .....	19
6.3	Connecting the encoder (electrically) .....	20
6.3.1	Connections .....	20
<b>7</b>	<b>Connection diagrams .....</b>	<b>21</b>
<b>8</b>	<b>Faults.....</b>	<b>23</b>
8.1	Fault table .....	23
<b>9</b>	<b>Inspections.....</b>	<b>23</b>
9.1	Safety instructions.....	23
<b>10</b>	<b>Data transmission modes using the example of an AMS 40-1312 encoder.....</b>	<b>24</b>
10.1	Maintenance information .....	25
10.2	Inspection schedule .....	25
<b>11</b>	<b>Disposal.....</b>	<b>26</b>
11.1	Disposal procedure .....	26
<b>12</b>	<b>Spare Parts.....</b>	<b>26</b>
<b>13</b>	<b>Dimension drawings.....</b>	<b>27</b>
13.1	Construction type B5 (flange).....	27
13.2	Construction type B35 (flange and foot) .....	29

## 1 General

### 1.1 Information about the Operating and Assembly Instructions

These Operating and Assembly Instructions provide important instructions for working with the device. They must be carefully read prior to starting all tasks, and the instructions contained herein must be followed.

In addition, applicable local regulations for the prevention of industrial accidents and general safety regulations must be complied with.

### 1.2 Scope of delivery

Absolute Encoder, Operating and Assembly Instructions.

### 1.3 Explanation of symbols

Warnings are indicated by symbols in these Operating and Assembly Instructions. The warnings are introduced by signal words that express the scope of the hazard.

The warnings must be strictly heeded; you must act prudently to prevent accidents, personal injury, and property damage.



#### **WARNING!**

Indicates a possibly dangerous situation that can result in death or serious injury if it is not avoided.



#### **CAUTION!**

Indicates a possibly dangerous situation that can result in minor injury if it is not avoided.



#### **CAUTION!**

Indicates a possibly dangerous situation that can result in material damage if it is not avoided.



#### **NOTES!**

Indicates useful tips and recommendations as well as information for efficient and trouble-free operation.



#### **NOTES!**

Do not use a hammer or similar tool when installing the device due to the risk of damage occurring to the bearings or coupling!



#### **DANGER!**

##### **Life-threatening danger due to electric shock!**

Indicates a life-threatening situation due to electric shock. If the safety instructions are not complied with there is danger of serious injury or death. The work that must be executed should only be performed by a qualified electrician.

## 1.4 Disclaimer

All information and instructions in these Operating and Assembly Instructions have been provided under due consideration of applicable guidelines, as well as our many years of experience.

The manufacturer assumes no liability for damages due to:

- Failure to follow the instructions in the Operating and Assembly Instructions
- Non-intended use
- Deployment of untrained personnel
- Opening of the device or conversions of the device

In all other aspects the obligations agreed in the delivery contract as well as the delivery conditions of the manufacturer apply.

## 1.5 Copyright



### NOTES!

Content information, text, drawings, graphics, and other representations are protected by copyright and are subject to commercial property rights.

It is strictly forbidden to make copies of any kind or by any means for any purpose other than in conjunction with using the device without the prior written agreement of the manufacturer. Any copyright infringements will be prosecuted.

## 1.6 Guarantee terms

The guarantee terms are provided in the manufacturer's terms and conditions.

## 1.7 Customer service

For technical information personnel is available that can be contacted by telephone, fax or email. See manufacturer's address on page 2.

# 2 Safety



### DANGER!

This section provides an overview of all the important safety aspects that ensure protection of personnel, as well as safe and trouble-free device operation.

If these safety instructions are not complied with significant hazard can occur.

## 2.1 Responsibility of the owner

The device is used in commercial applications. Consequently the owner of the device is subject to the legal occupational safety obligations and subject to the safety, accident prevention and environmental protection regulations that are applicable for the device's area of implementation.

## 2.2 Intended use

The device has been designed and constructed exclusively for the intended use described here.

Series AMS 40 / ASS 40 Absolute Encoders are used for measurement of rotations, for instance of electrical and mechanical drives and shafts.

Claims of any type due to damage arising from non-intended use are excluded; the owner bears sole responsibility for non-intended use.

---

## 2.3 Non - intended use

- Do not use the device in potentially explosive areas.
- The device must not be subjected to mechanical loads in addition to its own weight and unavoidable vibration and shock loads that arise during normal operations.

Examples for non-permitted mechanical loads (incomplete list):

- Fastening transport or lifting tackle to the device, for example a crane hook to lift a motor.
- Fastening packaging components to the device, for example ratchet straps, tarpaulins etc.
- Using the device as a step, for example by people to climb onto a motor.

## 2.4 Personnel

Installation and commissioning as well as disassembly routines must be carried out by skilled technical staff only.

## 2.5 Personal protective equipment

For tasks such as assembly, disassembly or commissioning the use of personal protective equipment such as safety footwear and protective work clothing is required.

The regulations specified by the owner and that are locally specified apply.

## 2.6 Special dangers

Residual risks that have been determined based on a risk assessment are cited below.

### 2.6.1 Electrical current



#### **DANGER!**

#### **Life-threatening danger due to electrical shock!**

There is an imminent life-threatening hazard if live parts are touched. Damage to insulation or to specific components can pose a life-threatening hazard.

#### **Therefore:**

Immediately switch off the device and have it repaired if there is damage to the insulation of the power supply.

De-energize the electrical equipment and ensure that all components are connected for all tasks on the electrical equipment.

Keep moisture away from live parts. Moisture can cause short circuits.

### 2.6.2 Rotating shafts / Hot surfaces



#### **WARNING!**

#### **Danger of injury due to rotating shafts and hot surfaces!**

Touching rotating shafts can cause serious injuries.

#### **Therefore:**

Do not reach into moving parts/shafts or handle moving parts/shafts during operation. Close to protect from injury all access openings in flanges with the corresponding plug screw, and provided you exposed rotating components with protective covers.

Do not open covers during operation. Prior to opening the covers ensure that all parts have come to a standstill.

The encoder can become hot during prolonged use.

In case of contact risk of burns is existing.

### 2.6.3 Safeguarding against restart



#### **DANGER!**

#### **Life-threatening danger if restarted without authorization!**

When correcting faults there is danger of the power supply being switched on without authorization.

This poses a life-threatening hazard for persons in the danger zone.

#### **Therefore:**

Prior to starting work, switch off the system and safeguard it from being switched on again.



### 3 Technical Data

#### 3.1 Type plate

Example Type plate:

<small>JOHANNES</small> <b>HÜBNER</b>  <small>GIESSEN</small> Siemensstrasse 7 · 35394 Giessen / Germany www.huebner-giessen.com	
<b>Absolutwertgeber / Absolute encoder AMS 40 K-1312</b>	
S/N <b>123456</b>	C/N <b>12345</b>
Bj./Y <b>2018</b>	<b>IP66</b>
max. Drehzahl <i>max. speed</i> <b>4000</b> rpm	Versorgungsspg./ <i>Supply voltage</i> <b>12...30 V DC, max. 4 W</b>
Singleturn <b>13</b> bit	<i>interface</i> <b>SSI</b>
Multiturn <b>12</b> bit	<i>code</i> <b>gray</b>
<b>Made in Germany</b>	

The type plate is located on the outside of the housing and contains the following information:

- Manufacturer, Address
- Type, Year of construction
- CE marking
- Serial number (S/N)
- Commission number (C/N)
- Resolution singleturn
- Resolution multiturn (not for type ASS)
- Protection class
- Power supply
- Interface
- Code

### 3.2 Electrical and mechanical data

<b>Connection data</b>				
Supply voltage	12...30 V DC			
No-load power consumption	approx. 1 W			
Resolution singleturn	Max. 13 bit (8192 steps per revolution) see type plate			
Resolution multiturn	12 bit (4096 revolutions) see type plate			
Data format	SSI, binary/gray code (see type plate)			
<b>SSI-Interface</b>				
Clock input	RS 422 / 5V			
Input current	5 mA			
Clock frequency	80kHz ... 1MHz			
Clock rate/transmission	25 / 13 (multiturn / singleturn)			
SSI – time out	> 30 µs (without data repetition) < 20 µs (with data repetition)			
Data interface	RS 422 / 5V			
<b>Control signals</b>				
V/R, Z (input)	5...30V / 5mA			
State (output)	HTL			
<b>Encoder temperature range</b>				
Standard	-25°C...+ 85°C			
Degree of protection acc. to DIN EN 60529	Sealing	Mech. permissible speed	Rotor moment of inertia	Breakaway torque
IP 66	with Labyrinth seal	≤ 6000 rpm	approx. 580 gcm <sup>2</sup>	approx. 6 Ncm
IP 66 / IP 67	with axial shaft seal	≤ 4000 rpm	approx. 510 gcm <sup>2</sup>	approx. 8 Ncm
IP 66 / IP 67	With radial shaft seal (for special applications, e.g. wet areas in rolling mills)	≤ 3000 rpm	approx. 510 gcm <sup>2</sup>	approx. 9 Ncm
Vibration resistance	DIN EN 60068-2-6 / IEC 68-2-6 (10 ... 2000 Hz)		20 g (=200 m/s <sup>2</sup> )	
Shock resistance	DIN EN 60068-2-27 / IEC 68-2-27 (6 ms)		150 g (=1500 m/s <sup>2</sup> )	
Max. encoder shaft load	F <sub>a, max.</sub> (axial) = 100 N F <sub>r, max.</sub> (radial) = 120 N			
Shaft dimensions	11j6 x 30 mm (standard) 14j6 x 30 mm (optional)			
Weight	Type K (construction type B5)		approx. 3,1 kg	

### 3.3 Type key

	AM	S	40	K	13	12
Absolute encoder						
M = multiturn						
S = singleturn						
SSI Interface						
Type						
Connection						
K = Terminal box						
R = 12- pole round plug type UTO Souriau						
S = 15- pole EMC industrial plug						
T = 12-pole round plug M 23						
Resolution						
Singleturn 12 bit/13 bit/15 bit (see type plate)						
Multiturn 12 bit (not for ASS)						

## 4 Transport, packaging and storage

### 4.1 Safety instructions for transport



**CAUTION!**

**Material damage caused by improper transport!**

Observe the symbols and information on the packaging:

- Do not throw - risk of breakage
- Keep dry
- Do not expose to heat above 40 °C or direct sunlight.

### 4.2 Incoming goods inspection

Check the delivery immediately upon receipt for transit damage or short delivery.

Inform the carrier immediately on receipt if you determine that damage has occurred during transit (take photos as proof).

### 4.3 Packaging / disposal

The packaging is not taken back and must be disposed of in accordance with the respective statutory regulations and local guidelines.

### 4.4 Storage of packages (devices)



**Keep dry**

Keep packages dry and free from dust; protect from moisture.



**Protect against heat**

Protect packages from heat above 40 °C and direct sunlight.

If you intend to store the device for a longer period of time (> 6 months) we recommend you use protective packaging (with desiccant).



**NOTES!**

Turn the shaft of the absolute encoder every 6 month to prevent the bearing grease solidifying!

## 5 Installation and commissioning

### 5.1 Safety instructions



#### NOTES!

Observe the safety instructions contained in **Chapter 2** when installing or working on the device!

#### Personnel

Installation and commissioning must be carried out by skilled technical staff only.

### 5.2 Technical information



#### NOTES!

Do not use a hammer or similar tool when installing the device due to the risk of damage occurring to the bearings or coupling!

#### Ambient temperature

The max. permissible ambient temperature depends on the speed and degree of protection of the device, the signal frequency, the length of the signal cable and the place of installation (please refer to chapter 3.2).

#### Degree of protection

To fulfill degree of protection requirements the diameter of the connection cable must correspond to that of the cable gland (please refer to chapter 13 dimension drawings)

#### Deep groove ball bearings

The absolute encoder AMS 40 K / ASS 40 K is fitted with maintenance-free, greased "for-life" deep groove bearings. Bearings must be changed by the manufacturer only. Opening the encoder renders the guarantee null and void.

#### Screw retention

We recommend using Loctite® 243 threadlocker (medium strength) on all fastening screws to prevent loosening.

### 5.3 Required tools

- Spanners: 10 mm, 22 mm, 24 mm
- Allen keys: 2 mm, 3 mm
- Flat-blade screwdrivers:
- Assembly grease
- Loctite® 243 (medium strength threadlocker)

## 5.4 Mounting preparations

1. Ensure all accessories are available (please refer to chapter 13 dimension drawings).



**NOTES!**

Fastening screws and earth cable are not included in the range of supply.

2. Preparing the place of attachment: Clean the (motor) shaft, centering, bolting surfaces and fastening threads; check for damage. Repair any damage!

## 5.5 Mounting B5 type (flange)



**NOTES!**

For a mounting example please refer to dimension drawing HM 09 M 57 263a Chapter 13

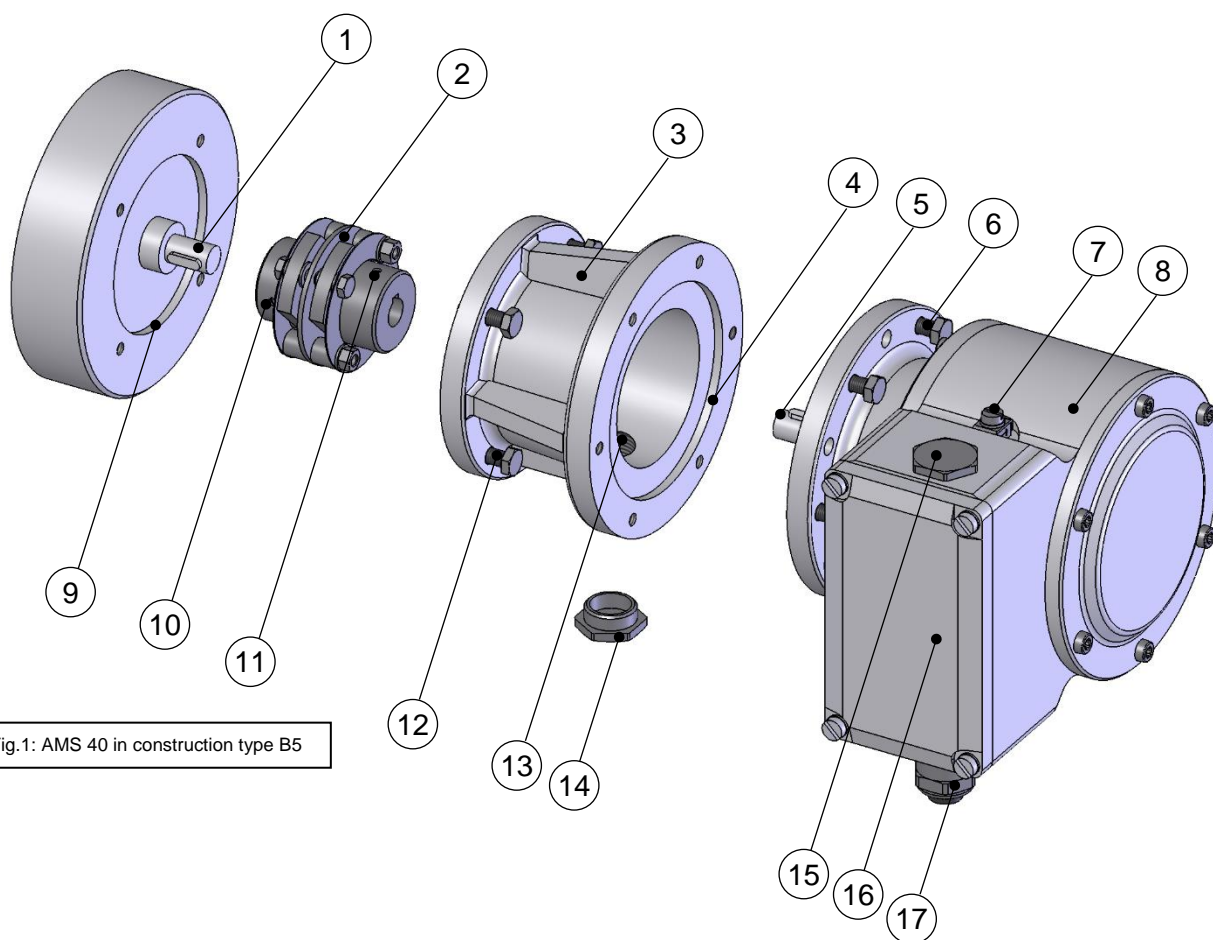

Fig.1: AMS 40 in construction type B5

1. Grease lightly the (motor) shaft (1) and centering (9).

2. Fit coupling (2) onto (motor) shaft.



**NOTES!**

You must be able to mount the coupling without force. Ream out the bores of used couplings, if necessary!

3. Secure the coupling hub on the (motor) shaft with a grub screw or cheese head screw (10) (depending on the coupling type).

4. Fasten the intermediate flange (3) to the motor using the fastening screws (12).



**NOTES!**

If possible, fit the intermediate flange in a manner that ensures the screwed sealing plug (14) points downwards!

5. Grease lightly the encoder shaft (5) and centering (4).

6. Fit the encoder (8) into both the centering (4) and coupling hub at the same time.



**NOTES!**

If possible, fit the device in a manner that ensures the cable gland points downwards. Exchange the position of the cable gland (16) and the blanking plug (15), if necessary.

7. Secure the encoder with 4 - 6 screws (6) evenly distributed around the circumference of the flange.

8. Remove the sealing plug (14) from the access bore (13) to the coupling.

9. Secure the coupling hub on the encoder shaft with a grub screw or cheese head screw (11) (depending on the coupling type).



**NOTES!**

To carry out this task, it may be necessary to turn the (motor) shaft to the correct position.

10. Replace the sealing plug to seal the access bore to the coupling with a plug screw (14).

## 5.6 Mounting B35 type (flange and foot)



**NOTES!**

B35 type encoders can be attached by means of a flange (B5, please refer to Chapter 5.5) or foot (B3):

For a mounting example please refer to dimension drawing HM 09 M 102 240a (Chapter 13.2).

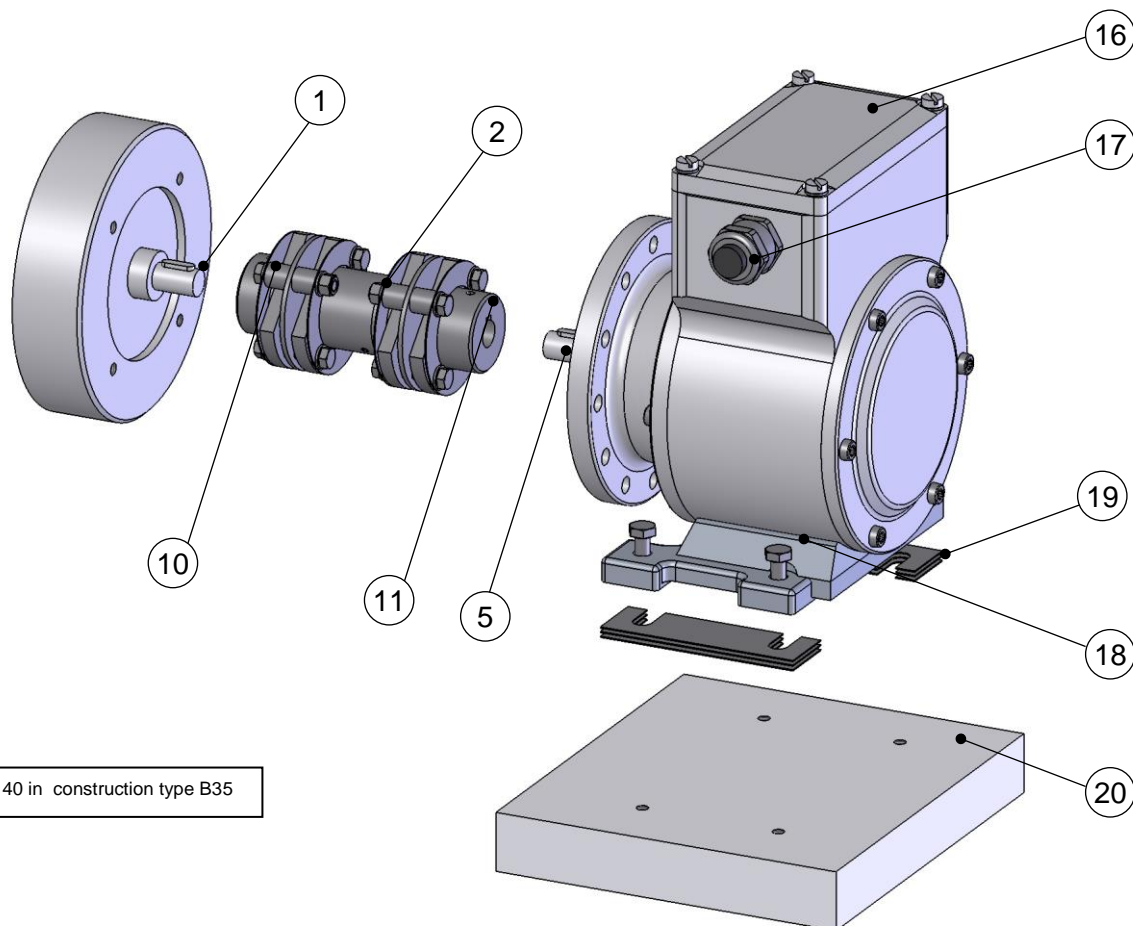

Fig.2: AMS 40 in construction type B35

1. Grease lightly the (motor) shaft (1).
2. Fit coupling (2) onto (motor) shaft.



**NOTES!**

You must be able to mount the coupling without force. Ream out the bores of used couplings, if necessary!



**NOTES!**

We recommend our zero-backlash, torsion-resistant **double-joint coupling HKD5** to attach B35 type encoders. Please refer to the catalogue *Torsion Resistant Couplings for Encoders*.

3. Secure the coupling hub on the (motor) shaft with a grub screw or cheese head screw (10) (depending on the coupling type).



4. Align the encoder shaft (5) to the (motor) shaft and insert into the coupling hub.



**NOTES!**

Use shims (19) to achieve the correct vertical alignment to the base plate (20).

**Observe information in Chapter 5.75.7 about mounting errors and max. permissible mounting tolerances!**

5. Fasten encoder foot with 4 M6 hexagon head screws (18).

6. Secure the coupling hub on the encoder shaft with the grub screw or cheese head screw (11) (depending on the coupling type).



**NOTES!**

To avoid injuries by turning parts, the coupling must be provided before introduction with a suitable cover.

## 5.7 Mounting tolerances for Construction Type B5 and B35



**NOTES!**

Angle misalignment and parallel displacement between the (motor) shaft and the encoder shaft are mounting errors and should be kept as small as possible.

**Mounting errors**

- Cause radial forces to act on the encoder shaft.
- Reduce the service life of the bearings and the coupling.
- Degrade the quality of the signals (harmonic content).

Mounting tolerances for our zero-backlash, torsion-resistant couplings HK5 and HKD5:

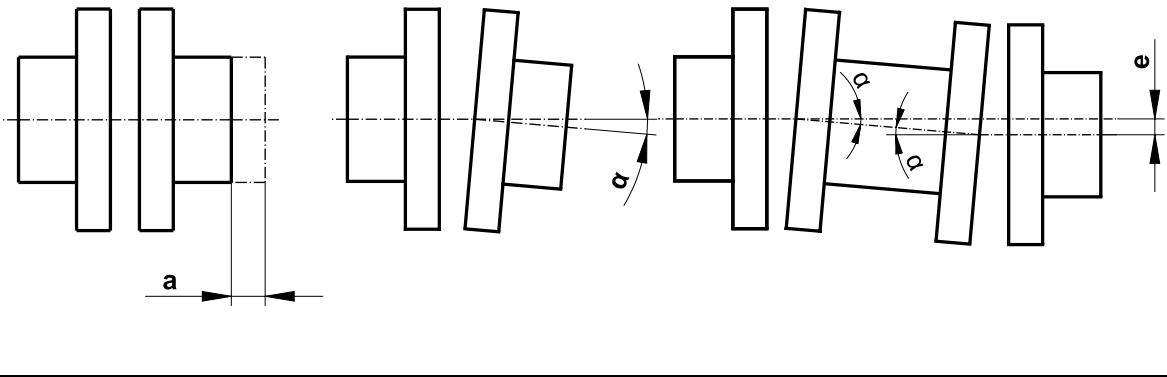

Coupling	Axial offset a	Angular error $\alpha$	Parallel offset e
HK 5	$\pm 1$ mm	$0.5^\circ$	-
HKD 5	$\pm 1.5$ mm	$0.5^\circ$	0.5 mm

## 5.8 Electrical connection and start up



### **SPECIAL NOTES!**

Installation must be carried out by skilled technical staff only.



### **NOTES!**

You must observe applicable EMC guidelines when routing cables!

### 5.8.1 Preparing cables

1. Strip cable insulation.
2. Crimp wire-end ferrules.

### 5.8.2 Electrical connection

1. Open the terminal box cover (16 Fig. 1).



### **CAUTION!**

Do not allow moisture to enter the terminal box when the cover is open!

2. Remove the cap of the cable gland (17 Fig.1).
3. Feed the cable into the terminal box trough the cable gland.



### **NOTE!**

The signal cable shielding can be connected directly to the housing via the EMC cable gland. A coil spring integrated in the cable gland ensures all-round contact is made with the bare cable shielding to ensure a good shield connection. This type fo shield connection should be preferred.

Alternatively, if equipotential boning currents are anticipated it is possible to connect the cable shielding to a shield terminal in the terminal box. A capacitor between the shield terminal and the encoder housing prevents the flow of equalizing current.

To achieve an effective shielding the cable shield must also be connected in the electrical cabinet.

4. Tighten the cable gland and blanking plugs using a spanner.



### **NOTES!**

Prior to delivery cable glands and blanking plugs are tightened finger tight only. To ensure that the terminal box is reliably sealed tighten all cable glands and blanking plugs before starting up for the first time.

5. Use a spanner to tighten the cable gland until the cable is securely clamped and properly sealed.

**NOTES!**

Prevent lateral pulling forces acting on the cable and plugs so as not to impair the degree of protection of the cable gland.

6. Connect the supply voltage and signal cable (please refer to the connection diagrams, chapter 7).

**CAUTION!**

Do not apply supply voltage to the signal outputs, as this will destroy the device!

7. Applicable to alternative shield connection only: fit cable lug to cable shield and connect to the shield terminal (please refer to the connection diagrams, chapter 7).

**NOTES!**

To achieve a good shielding effect the cable shield be kept as short as possible.

8. Close the terminal box cover.

**NOTES!**

Before closing the terminal box cover check and if necessary clean both seal surfaces and the gasket.

**CAUTION!**

Ensure when closing the terminal box cover that no cable becomes jammed.

9. Secure earth cable to earth terminal (7, Fig.1).

## 6 Dismantling

### 6.1 Safety instructions

#### Personnel

Dismantling must be carried out by skilled technical staff only.

**WARNING!**

Observe the safety instructions contained in **Chapter 2** when dismantling the device!

**NOTES!**

Do not use a hammer or similar tool when installing the device due to the risk of damage occurring to the bearings or coupling!

### 6.2 Dismantling the absolute encoder

To dismantling the absolute encoder follow the instructions given in chapters 5.5, 5.6 and 5.8 in the reverse order.

## **6.3 Connecting the encoder (electrically)**

### **6.3.1 Connections**

Cable glands are closed with a stopper to protect the devices on transport and storage.

Cable connections have to be executed according to the encoder type.

**Connection diagrams have to be considered!**

See connection diagram and in the terminal box.

Use of connection cables with diameter of min. 9 mm – max. 13 mm is essential to ensure the protection class. Cable outlet should show preferably downwards.

**Wiring arrangement and shielding:**

(EMC measurement)

The cable shielding has to be connected on both ends!

The shield of the signal cable can be connected directly to the housing of the encoder by the cable gland.

The common guidelines for EMC concerned cable routing have to be considered!

## 7 Connection diagrams

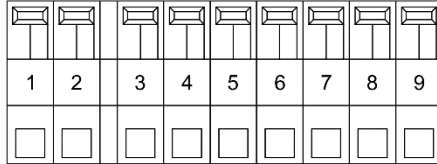

### Anschlussdaten:

**K1,K2**  
Aderquerschnitt  
0,25-1,5 [ mm<sup>2</sup> ]  
**K3...K9**  
Aderquerschnitt  
0,25-0,5 [ mm<sup>2</sup> ]

### Connection data:

**K1,K2**  
wire section  
0.25-1.5 [ mm<sup>2</sup> ]  
**K3...K9**  
wire section  
0.25-0.5 [ mm<sup>2</sup> ]

Internal connector	Function
1	GND
2	+UB
3	CLCK
4	CLCKG
5	DATA
6	DATAG
7	STATUS
8	V/R
9	Z

**AMS 40**  
**ASS 40**

**Standard**

**Terminal box**

Ansicht auf Geräteanschluss

Socket insert view

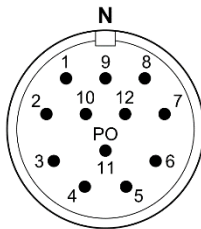

Schirmung:

Der Schirm der Signalleitung ist direkt mit dem Steckergehäuse zu verbinden.

Shield:

The shield of the signal cable is connected at the socket housing.

M23-Stecker M23 plug	Anschlussplan Connection diagram	PN178-460 PN178-460
1	GND	GND
2	+UB	Versorgungsspannung Power Supply
3	CLCK	Takt Clock
4	CLCKG	Takt invers Clock inverse
5	DATA	Daten Data
6	DATAG	Daten invers Data inverse
7	Z	Steuereingang Z Control input Z
8	V/R	Steuereingang V/R Control input V/R
9	STATUS	Status-Ausgang (low aktiv) Status output (low active)
10	-	-
11	-	-
12	-	-

**AMS 40**  
**ASS 40**

**12-pole plug M 23**

Ansicht auf Steckdoseneinsatz  
Socket insert view

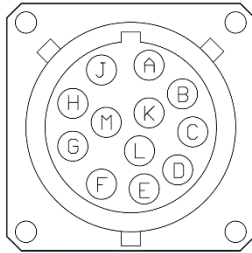

Crimpkontakte für Drahtquerschnitte  
0,52 bis 1,5mm<sup>2</sup>  
Crimp contacts for cross-sectional data  
of wire from 0.52 up to 1.5mm<sup>2</sup>

**Schirmung:**  
Der Schirm der Signalleitung ist direkt mit dem Steckergehäuse zu verbinden.

**Shield:**  
The shield of the signal cable is directly to be connected with the socket housing.

Crimpzange: Burndy Nr. MR 8 GE 5  
Crimping tool: Burndy No. MR 8 GE 5

Burndy-Stecker <i>Burndy plug</i>		Anschlussplan <i>Connection diagram</i>		PN178-450 <i>PN178-450</i>
A	CLCK	Takt		<i>Clock</i>
B	CLCKG	Takt invers		<i>Clock inverse</i>
C	DATA	Daten		<i>Data</i>
D	DATAG	Daten invers		<i>Data inverse</i>
E	-	-		-
F	-	-		-
G	STATUS	Status-Ausgang (low aktiv)		<i>Status output (low active)</i>
H	V/R	Steuereingang V/R		<i>Control input V/R</i>
J	Z	Steuereingang Z		<i>Control input Z</i>
K	-	-		-
L	+UB	Versorgungsspannung		<i>Power Supply</i>
M	GND	GND		<i>GND</i>

**AMS 40  
ASS 40**

**12-pole round plug**

Ansicht auf Steckdoseneinsatz  
Socket insert view

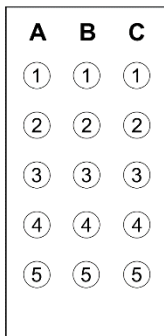

**Anschlussdaten:**  
Crimpkontakte für Drahtquerschnitte  
0,75-1,0 [mm<sup>2</sup>]  
**Connection data:**  
Crimp contacts for cross-Sectional data of wire  
0.75-1.0 [mm<sup>2</sup>]

**Schirmung:**  
Der Schirm der Signalleitung muss über die Kabelverschraubung direkt mit dem Gehäuse verbunden werden.

EMV-Industriestecker <i>EMC industrial plug</i>		Anschlussplan <i>Connection diagram</i>		PN178-440 <i>PN178-440</i>
C5	0V		GND	<i>GND</i>
A5	12...30V		Versorgungsspannung	<i>Power Supply</i>
A1	-		-	-
A2	-		-	-
A3	-		-	-
A4	-		-	-
B1	V/R		Steuereingang V/R	<i>Control input V/R</i>
B2	Z		Steuereingang Z	<i>Control input Z</i>
B3	-		-	-
B4	-		-	-
B5	STATUS		Status-Ausgang (Low aktiv)	<i>Status output (Low active)</i>
C1	DATA		Daten	<i>Data</i>
C2	DATAG		Daten invers	<i>Data inverse</i>
C3	CLCK		Takt	<i>Clock</i>
C4	CLCKG		Takt invers	<i>Clock inverse</i>

**AMS 40  
ASS 40**

**EMC industrial plug**

## 8 Faults

### 8.1 Fault table

Faults	Possible cause	Remedy
Moisture in the terminal box cover	Soiled gasket or seal surfaces of terminal box cover	Clean gasket of terminal box cover and seal surfaces
	Damaged gasket of terminal box cover	Replace gasket of terminal box cover
	Cable gland/blanking plug not tightened	Tighten cable gland/blanking plug
	Unsuitable cable for cable gland	Use suitable cable and cable glands

## 9 Inspections

### 9.1 Safety instructions



**WARNING!**

Skilled technical staff only are permitted to inspect the device and its installation. Observe the safety instructions contained in **chapter 2** when inspecting or working on the device!

## 10 Data transmission modes using the example of an AMS 40-1312 encoder

Data transmission:

Data transmission is effected acc. to SSI processing (Serial Synchronous Interface). This means the encoder input „CLCK“ and CLCKG“ (inverted) will be supplied with sets of 13 clockpulses through an opto coupler input for electrical isolation. Synchronously 13 data bits will be available at the output „DATA“ and inverted signals at the output „DATAG“ through Interface RS422.

The inactive level of clock signal is normally set at HIGH. On first falling edge the encoder position will be read from the code discs. The first transmission bit will then be supplied to the encoder output with the rising edge of clock 1 enabling the receiver unit to read the transmission bit with the falling edge of clock 1. This procedure will be repeated up to clock 13 and in this manner all data bits will be transmitted.

Data transmission will end at rising edge of clock input. In normal operation the output will be set to level „HIGH“ after approx. 25  $\mu$ s and readiness for next data transmission will be indicated to the receiver unit.

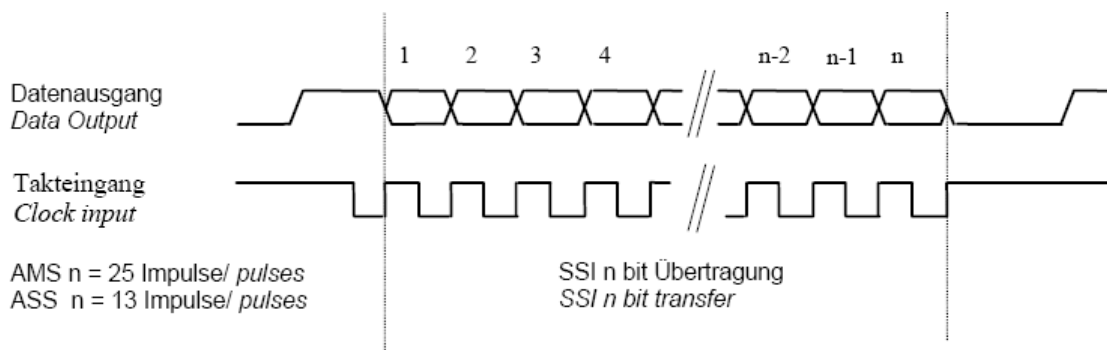

If a new data transfer is started within 20  $\mu$ s, no data reading from the code discs will be made but data of the previous cycle will be transmitted again (data repetition).

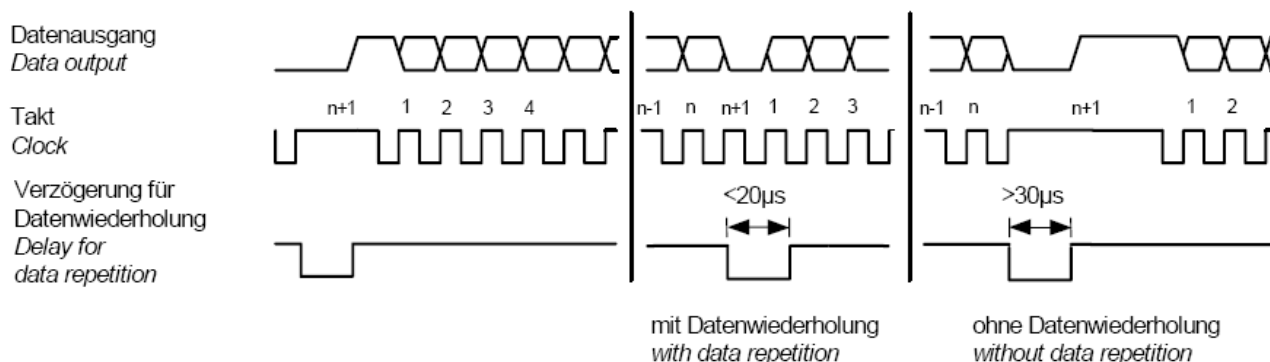



### Status-output

A signal indicating operation of the encoder will be generated on the output „Status“ as follows:  
While operating accurately a high level will be generated on „Status“. Low on signal „Status“ indicates non-correct operating of the SSI encoder.

### Control input V/R

Position values when the shaft rotates clockwise.

Standard:

0 V to terminal V/R

or no available connection :      Position increasing ↑

Reversion:

U<sub>B</sub> to terminal V/R:                      Position decreasing ↓



### Control input Z

The current position data is set to the preset value when having a pulse from min. 100 ms length (+10 V ... +30 V)

## 10.1 Maintenance information

The device is maintenance-free. However, to guarantee optimum fault-free operations we recommend that you carry out the following inspections.

## 10.2 Inspection schedule

Interval	Inspections
Yearly	Inspect the coupling
	Ensure the fastening screws are properly tightened
	Inspect cable connections
Following approx 16 000 ... 20 000 hours of operation / higher levels of continuous load	Check deep groove ball bearings are running smoothly and listen for running noises

## 11 Disposal

### 11.1 Disposal procedure

The manufacturer is not obliged to take back the device.

The device is classed as electronic equipment and subject to the WEEE Directive; observe local, country-specific laws when disposing of the device.

For information on environmentally sound disposal please contact your local authority or a specialist disposal company.

## 12 Spare Parts

The in the following listed spare parts can be covered when required about the service address on the page 2.

Spare part	Remark
Cover	Cover of the second shaft end
Cable gland	M20 x 1,5
Terminal box cover	Incl. o-ring and screws
Feather key	Indicate shaft or keyway dimensions
Locking screw	For closing the access to the coupling

## 13 Dimension drawings

Further dimension drawings on our website or on request.

### 13.1 Construction type B5 (flange)

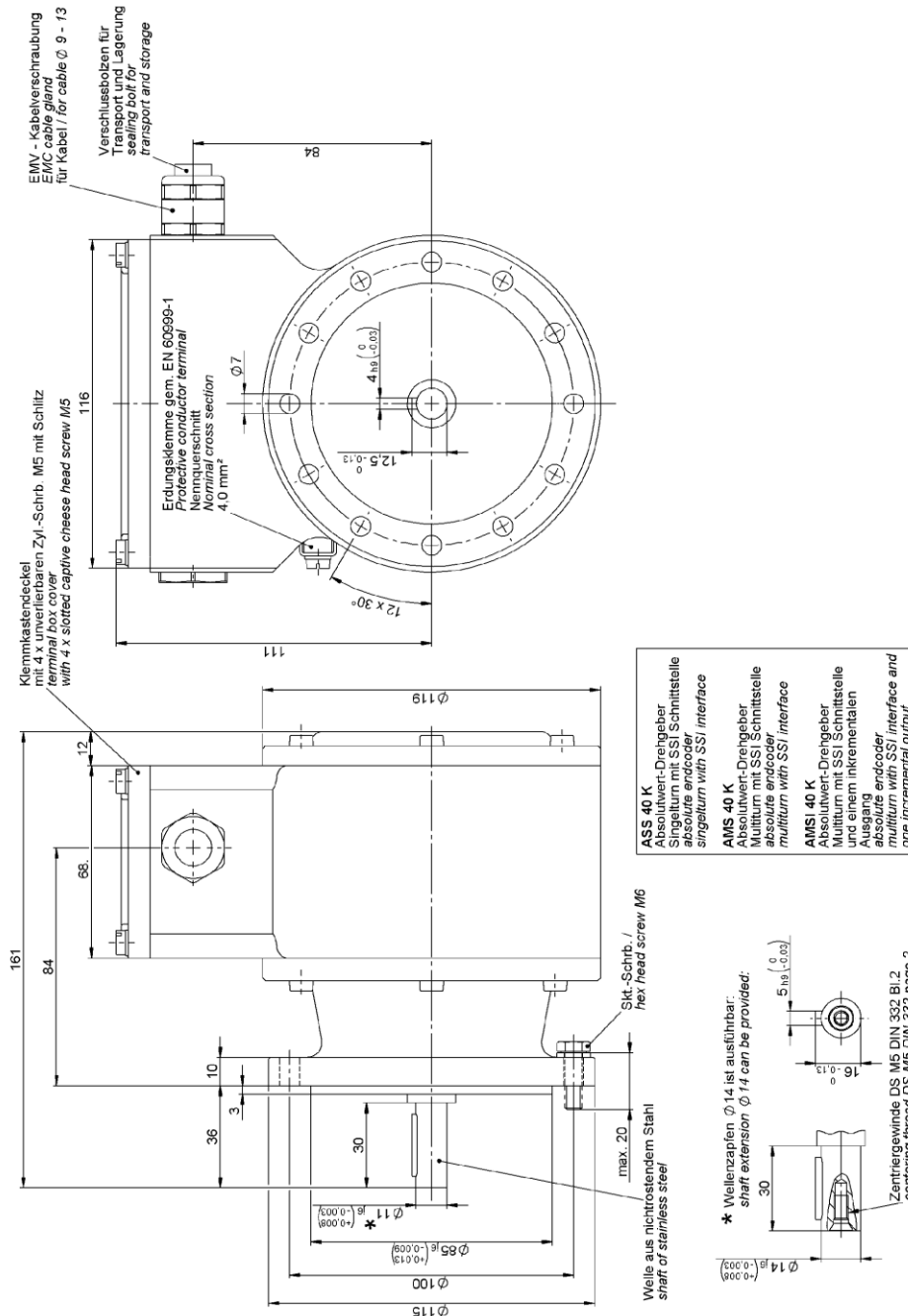

AMS 40 K / ASS 40 K

With radial terminal box

HM 12 M 104882

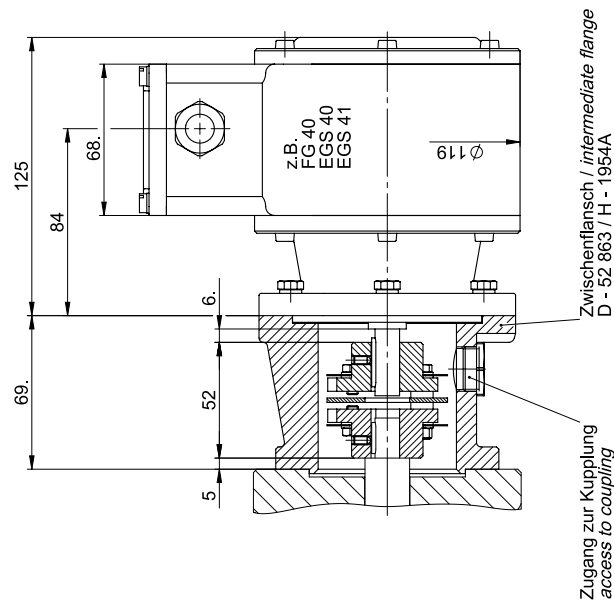
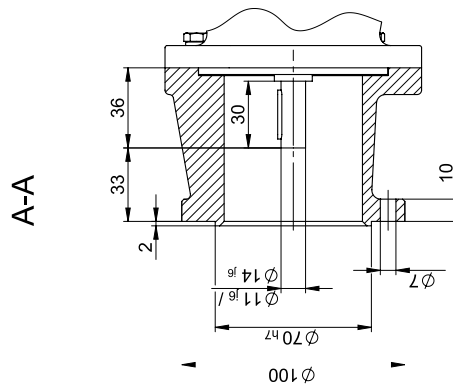
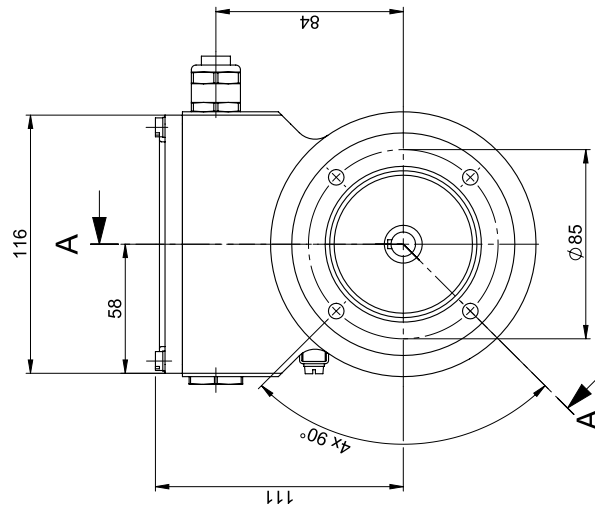

AMS 40 K/ASS 40 K

Example: construction type B5 with  
intermediate flange and coupling HK 522

HM 09 M 57 263a

# Absolute Encoder AMS 40 ASS 40

## 13.2 Construction type B35 (flange and foot)

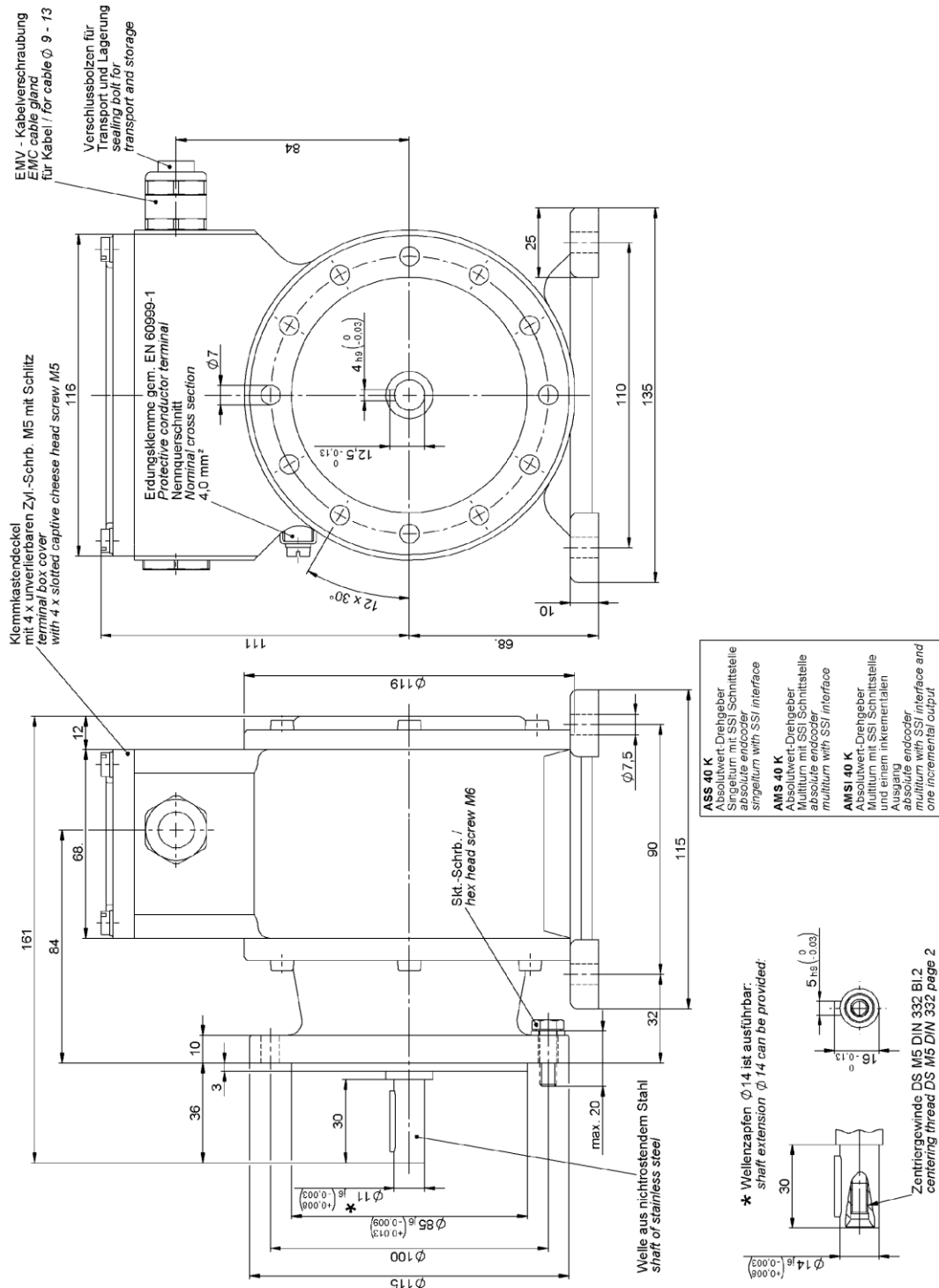

AMS 40 K / ASS 40 K

With radial terminal box

HM 12 M 104907a

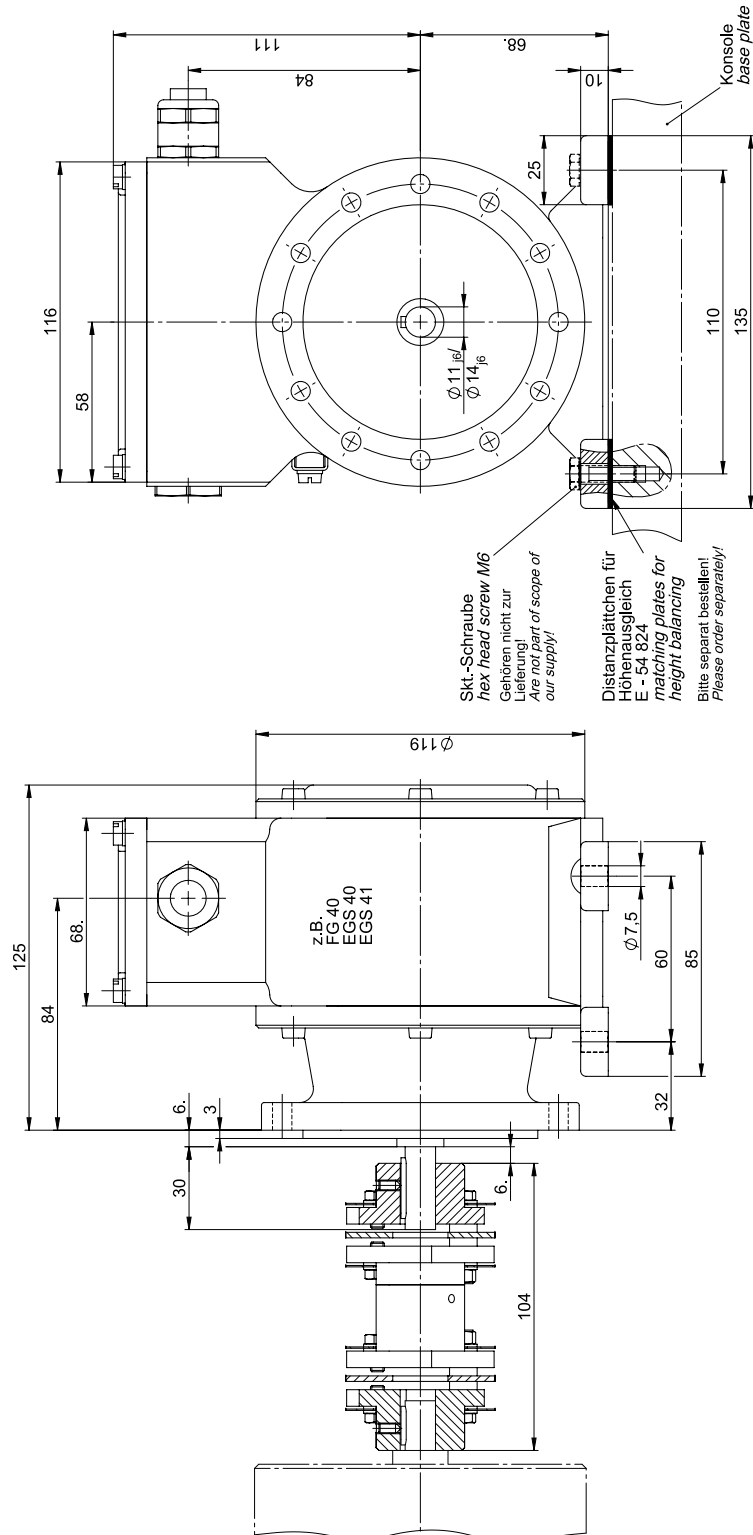

AMS 40 K / ASS 40 K

Example: construction type B35  
with coupling HKD 522

HM 09 M 102 240a

# Absolute Encoder AMS 40 ASS 40

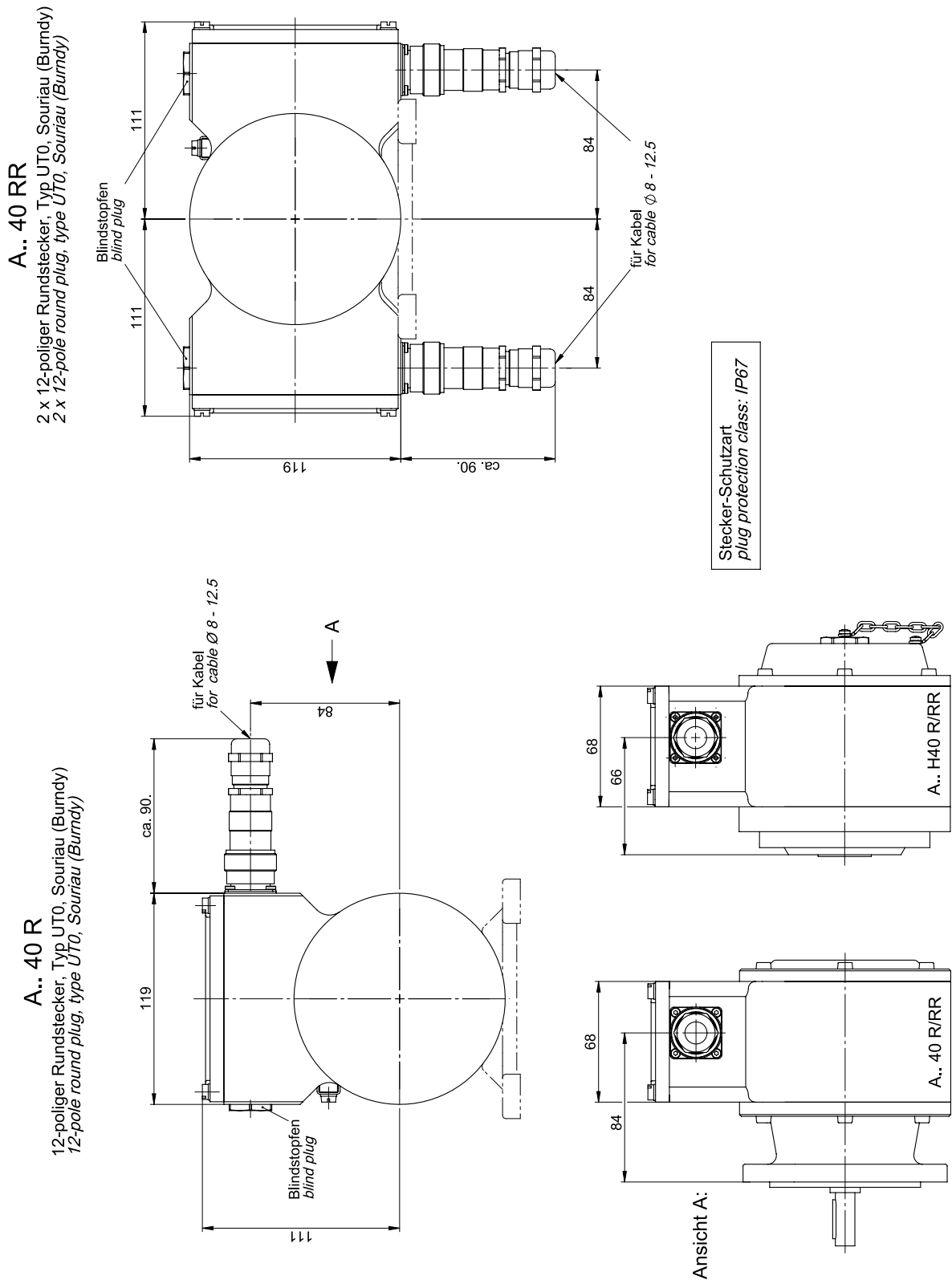

AMS 40 R / ASS 40 R

additional dimension drawing  
12-pole. round plug

HM 15 M 109130

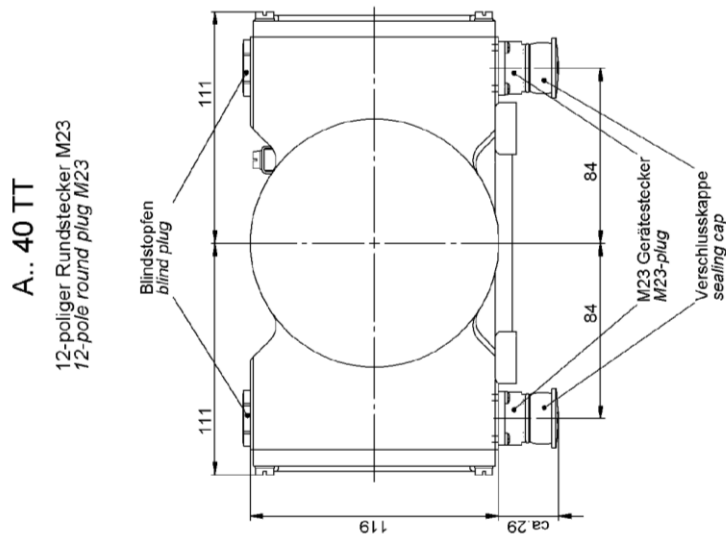

Stecker-Schutzart  
plug protection class: IP67

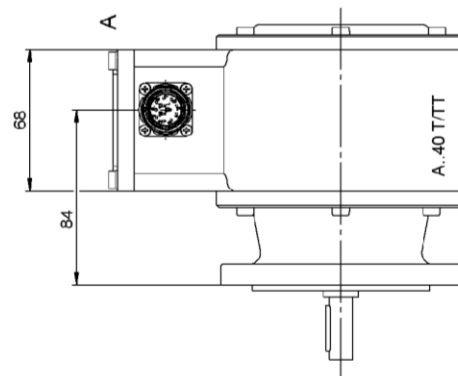
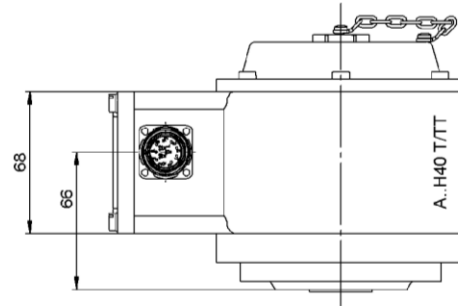
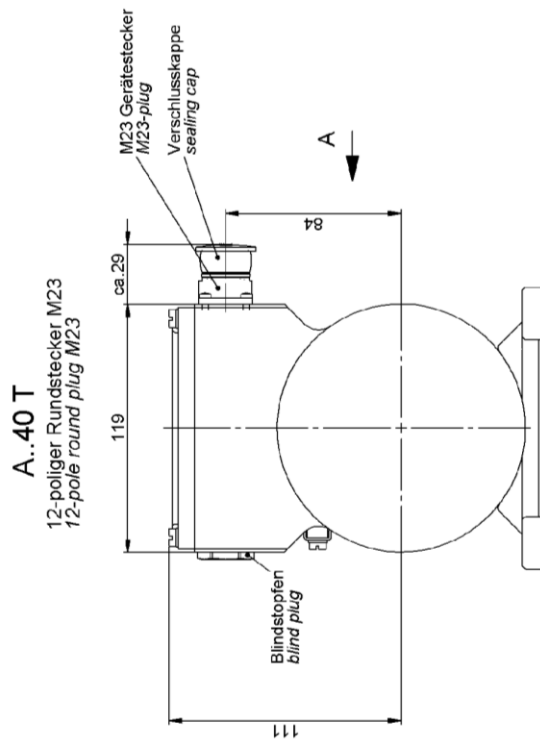

**AMS 40 T / ASS 40 T**

**additional dimension drawing  
12-pole plug M 23**

**HM 15 M 109157**



# Absolute Encoder AMS 40 ASS 40

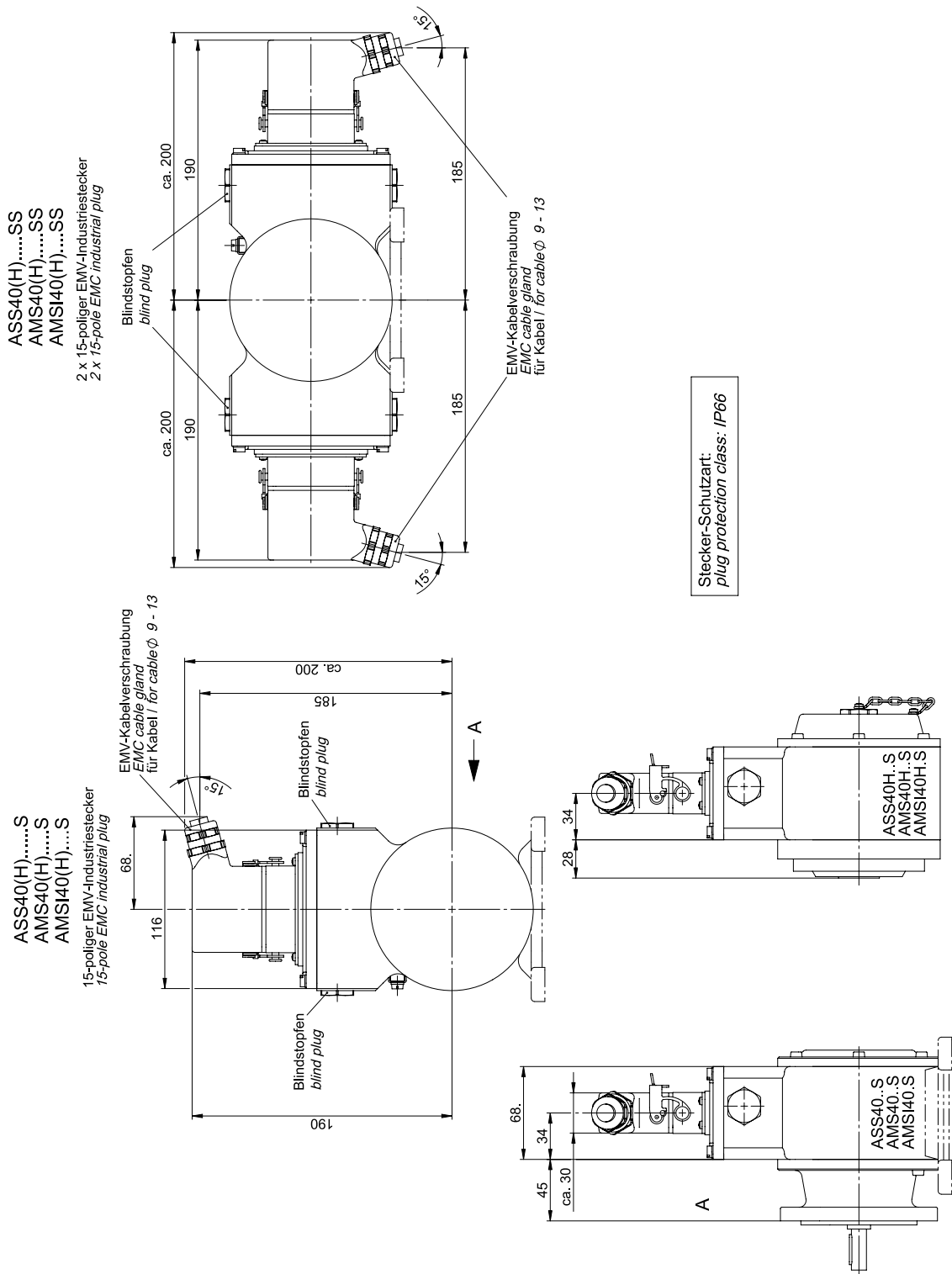

AMS 40 S / ASS 40 S

additional dimension drawing  
15-pole EMC industrial plug

HM 15 M 108974