

PosiTector® 6000 Order Guide

		Our most popular Integral and Cabled probe models			90° Regular probe for tight spots	Ideal for duplex coating systems	Ideal for hot and rugged applications	Ideal for anodized aluminum	Microprobes – Our smallest probes for small parts or hard-to-reach areas				Integral and Cabled probes for thick protective coatings; epoxy, rubber, intumescent fireproofing and more								
FERROUS	Standard	F1	FS1	FRS1		FXS1 ¹		FOS1	F45S1	F90S1	F90ES1		FT1	FTS1	FTRS1	FHXS1 ^{1,2}	FKS1	FJS1	FLS1		
	Advanced	F3	FS3	FRS3		FXS3 ¹		FOS3	F45S3	F90S3	F90ES3		FT3	FTS3	FTRS3	FHXS3 ^{1,2}	FKS3	FJS3	FLS3		
NON-FERROUS	Standard	N1	NS1	NRS1				NAS1	NOS1	N45S1	N90S1						NKS1				
	Advanced	N3	NS3	NRS3				NAS3	NOS3	N45S3	N90S3						NKS3				
COMBINATION	Standard	FN1	FNS1	FNRS1	FNDS1 ³									FNTS1						FNGS1 ⁴	
	Advanced	FN3	FNS3	FNRS3	FNDS3 ³									FNTS3							FNGS3 ⁴
Range		0–60 mils 0–1500 µm			0–80 mils 0–2000 µm	Ferrous: 0–45 mils and 0–1150 µm Non-Ferrous: 0–25 mils and 0–625 µm				0–250 mils 0–6 mm		0–400 mils 0–10,000 µm		0–500 mils 0–13 mm		0–1.0 in. 0–25 mm		0–1.5 in. 0–38 mm		0–2.5 in. 0–63.5 mm	
Accuracy ⁵		±(0.05 mil + 1%) 0-2 mils ±(0.1 mil + 1%) >2 mils			±(1 µm + 1%) 0-50 µm ±(2 µm + 1%) >50 µm	±(0.02 mil + 1%) 0-4 mils ±(0.1 mil + 3%) >4 mils				±(0.5 µm + 1%) 0-100 µm ±(2 µm + 3%) >100 µm		±(0.5 mil + 1%) 0-100 mils ±(0.5 mil + 3%) >100 mils		±(0.1 mil + 3%)		±(1 mil + 3%)		±(0.01 in. + 3%) ±(0.2 mm + 3%)			
Matching DeFelsko Calibration Standards		STDS1 STDA1			STDS4	STDS2 STDA2				STDP1		STDP7		STDP5		STDP2		STDP8			

Ferrous probes measure non-magnetic coatings on ferrous metals. **Non-Ferrous probes** measure non-conductive coatings on non-ferrous metals. 1) **FXS/FHXS Xtreme probe series** with Alumina wear face and braided cable — ideal for rough or hot surfaces up to 250° C (500° F). 2) **FHXS probe** measures non-conductive coatings on steel only. 3) See website for full **FNDS probe** accuracy information. 4) **FNGS probe** measures non-conductive coatings on all metals. 5) Accuracies are stated as a fixed value plus a percentage of the gage's actual reading.

Probe Details (All probe details can be found online at www.defelsko.com/p6000/probes)

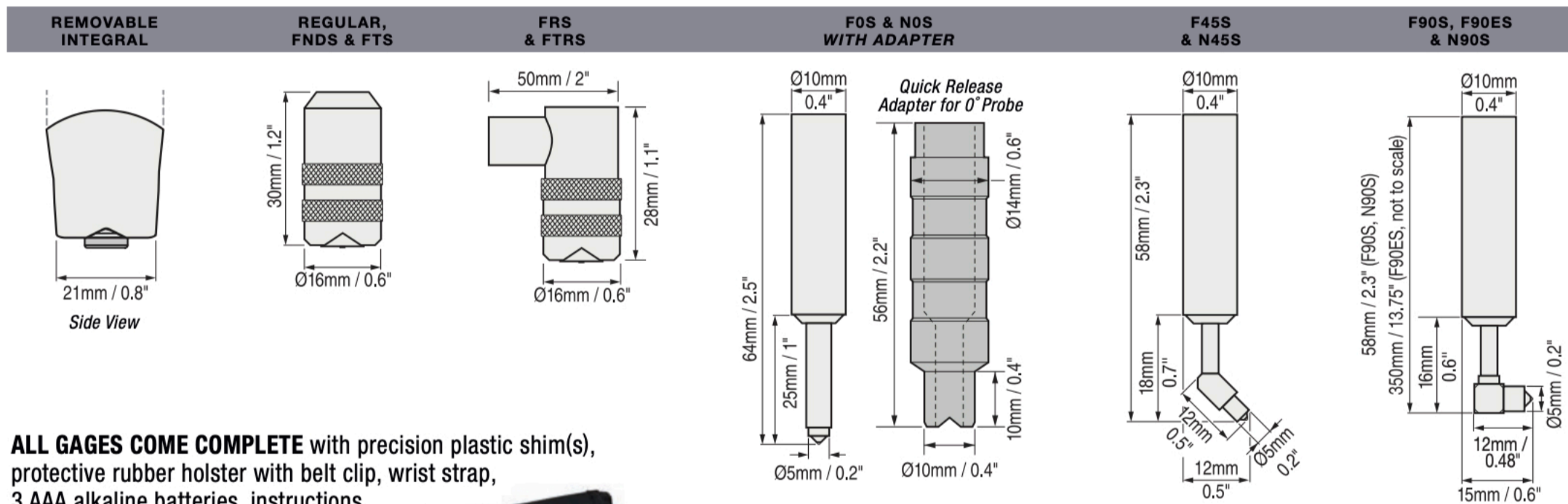

ALL GAGES COME COMPLETE with precision plastic shim(s), protective rubber holster with belt clip, wrist strap, 3 AAA alkaline batteries, instructions, protective lens shield, convenient carrying case, Long Form Certificate of Calibration traceable to NIST or PTB, USB cable, PosiSoft Software, two (2) year warranty.

SIZE: 137 x 61 x 28 mm (5.4" x 2.4" x 1.1")

WEIGHT: 140 g (4.9 oz.) without batteries

Conforms to ISO 2178/2360/2808, ISO 19840, ASTM B244/B499/D1186/D1400/D7091/E376/G12, BS3900-C5, SSPC-PA2 and others



Options

Coating Thickness Standards to fulfill both ISO and in-house quality control requirements

Probe Foot Rings Durable Delrin ring allows the probe to slide easily while scanning

Telescopic Probe Extender for use with the PosiTector 6000 FS, NS, FNS, FXS, FNDS, NAS and FTS probes.

- Provides up to 124 cm (49") of reach and collapses to 47 cm (18.5") for easy storage

For a complete list of product features and available options visit www.defelsko.com

