

LE MISURE GENERALI
ESTERNE ED INTERNE
NELLA VERSIONE EU E
USA/CAN SONO LE STESS

THE GENERAL EXTERNAL AND
INTERNAL MEASURES
IN THE EU AND US/CAN
VERSION ARE THE SAME

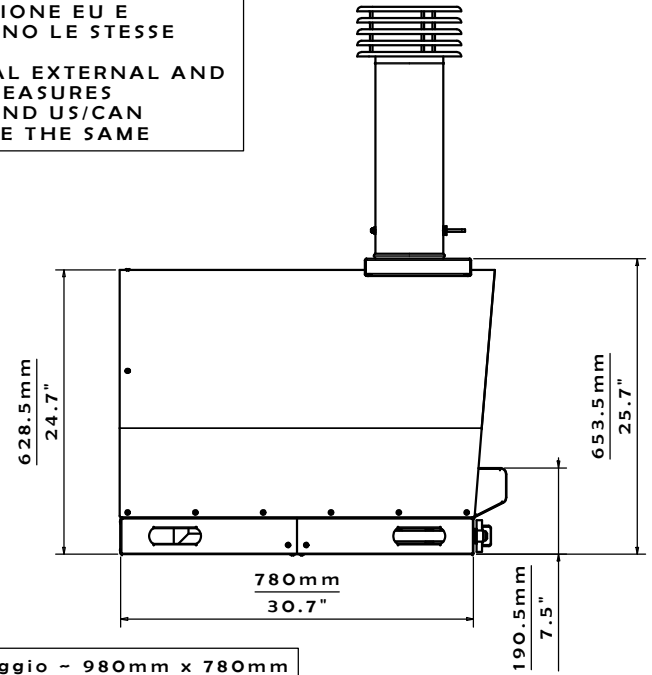

misure base di appoggio - 980mm x 780mm
support base measures - 38,6" x 30,7"

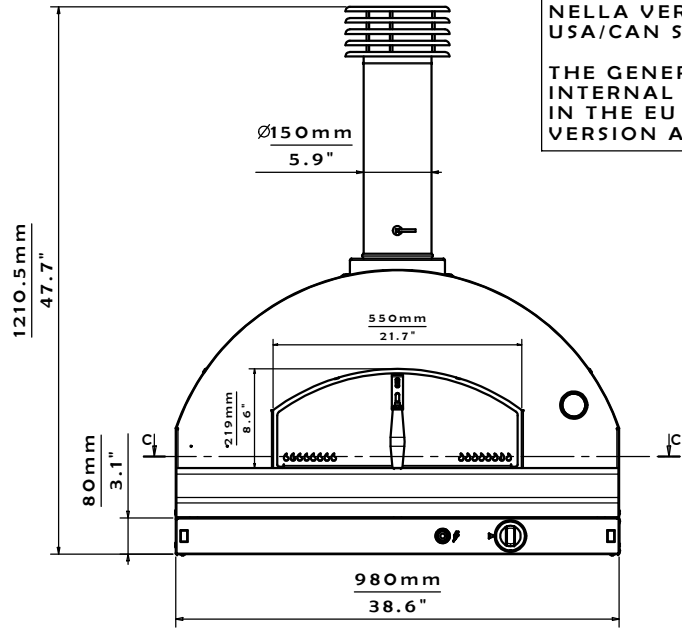
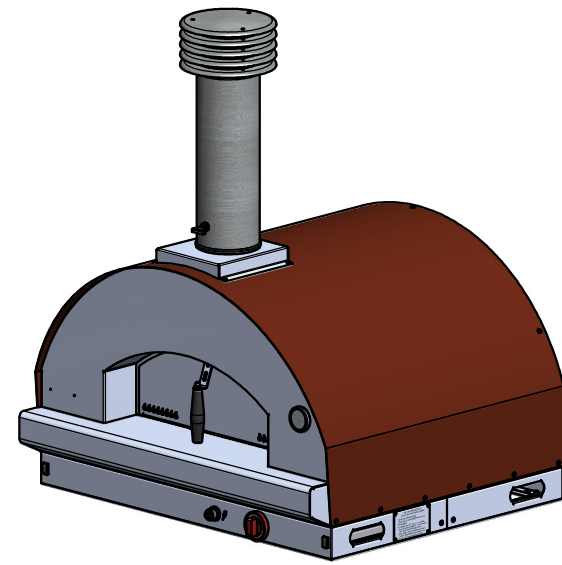
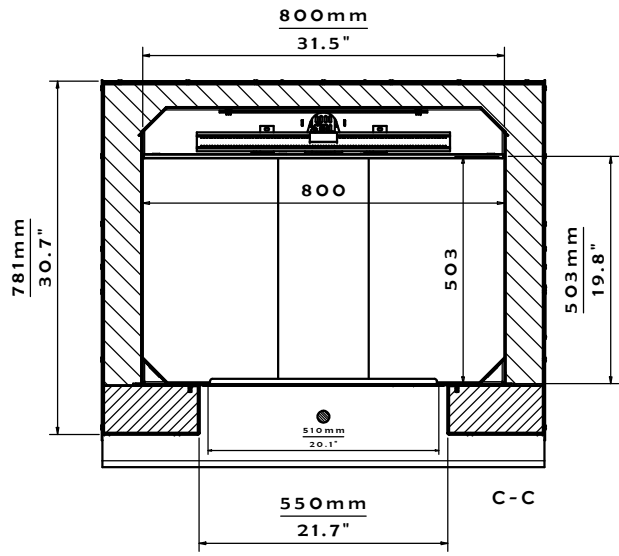

VISTA DA SOTTO
BOTTOM VIEW

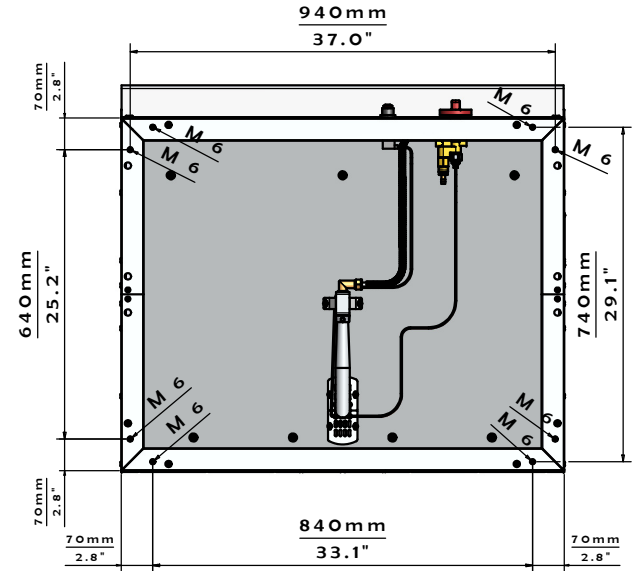

holes for support feet=M6
SUPPORT FEET PROVIDED n° 4
CHOOSE THE HOLE MOST SUITABLE
FOR THE SUPPORT FOOT.

REVISIONE / REVIEW 2020

rev.00	tubo/camino da-a (chemney/stack from-to) Ø140 - Ø150				
FONTANA	RAGGIO INTERNO PIEGA(mm)	TIPO DI CAVA CONSIGLIATO	TATTAMENTO SUPERFICIALE	//	
	//	//	colore / note	RAL	
	Generica	//	MATERIALE	//	
MACCHINA	GRUPPO	A-ASSIEME P-PARTICOLARE C-COMMERCIALE PRE-PREASSEMBLATO	QUANTITA'	PESO Kg	
serie **	FORNI		1	~125	
FORMATO	SCALA	CODICE			
***	1:1	MANGIAFUOCO-GAS(EU)			
DATA	DESCRIZIONE	MODELLO 8050-1			PROG. PIEGA
***					-----

Questo disegno e' proprieta' riservata di FONTANA vietata ogni riproduzione o divulgazione a terze parti se non autorizzata