



















ASSEMBLY INSTRUCTIONS (INSTRUCTIONS D'ASSEMBLAGE)

HARDWARE LIST :

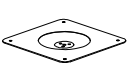
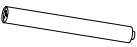
NO.	SKETCH	DESCRIPTION	QTY
A		Screw (Ø4*12mm) Vis	4 PCS
B		Bolt(M12*90MM) Boulon	1 PC
C		Washer(M12) Rondelle plate	1 PC
D		Spring washer(M12) Rondelle frein	1 PC
E		Allen wrench(M10) Clé hexagonale	1 PC
F		Bolt(1/4"*5/8") Boulon	4 PCS
G		Washer(1/4") Rondelle plate	4 PCS
H		Spring washer(1/4") Rondelle frein	4 PCS
I		Allen wrench(M4) Clé hexagonale	1 PC
J		Bolt(M8*20MM) Boulon	3 PCS
K		Bolt(M8*65MM) Boulon	3 PCS
L		Washer(M8) Rondelle plate	6 PCS
M		Spring washer(M8) Rondelle frein	6 PCS
N		Allen wrench(M5) Clé hexagonale	1 PC

PARTS LIST :

NO.	SKETCH	DESCRIPTION	QTY
1		Table top Dessus de table	1 PC
2		Connecting iron plate Plaque en acier de raccordement	1 PC
3		Support bar Barre de support	1 PC
4		Counter weight Contrepoids	1 PC
5		Base Base	1 PC
6		Connecting iron Plate Plaque en acier de raccordement	1 PC

Step 1

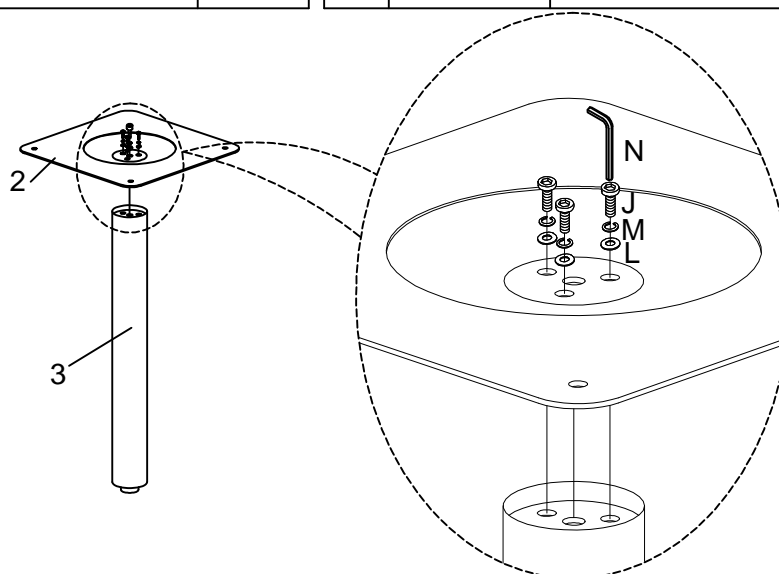

ASSEMBLY INSTRUCTIONS (INSTRUCTIONS D'ASSEMBLAGE)

Step 2

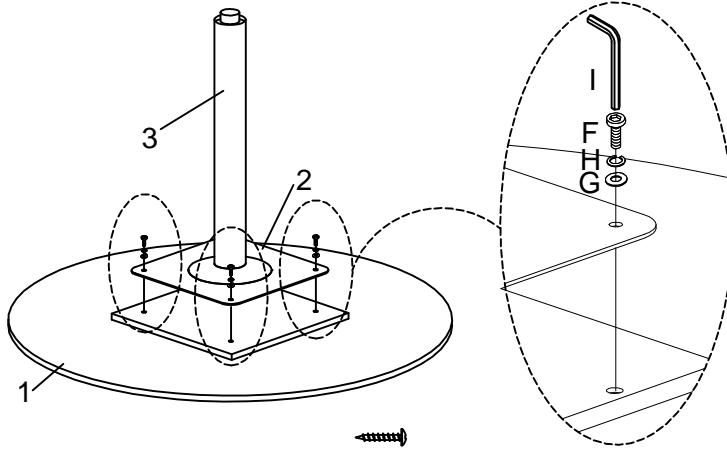

Step 3

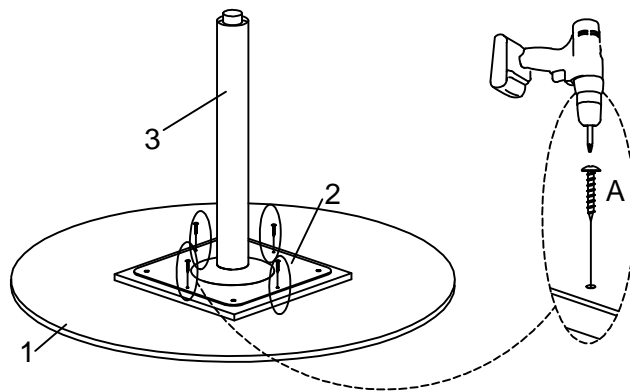

Step 4

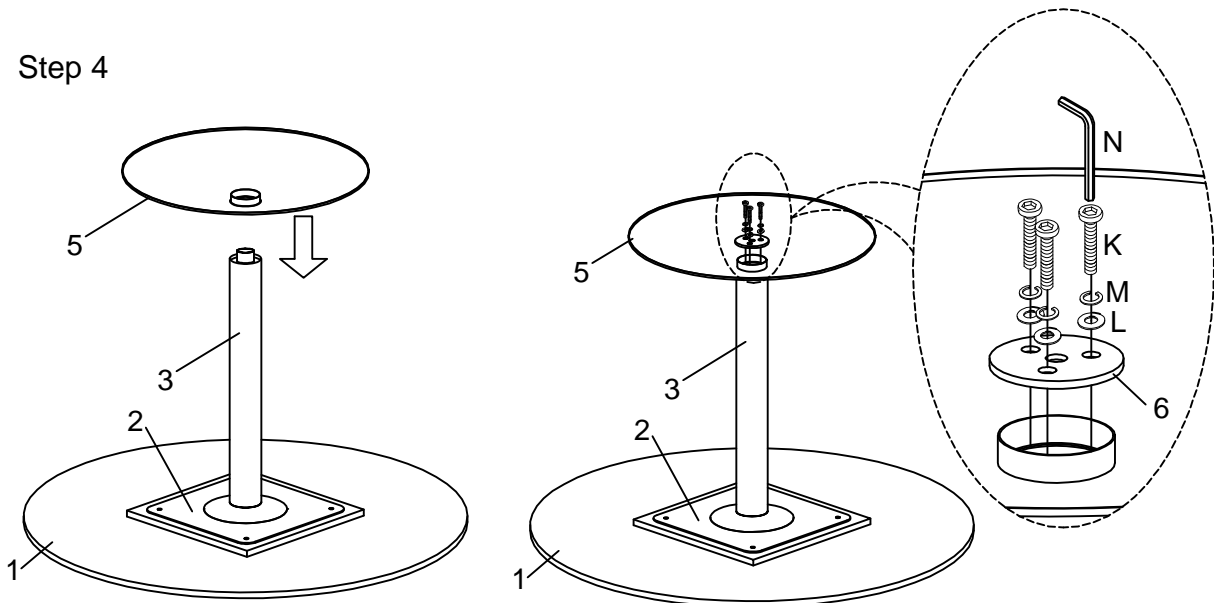

ASSEMBLY INSTRUCTIONS (INSTRUCTIONS D'ASSEMBLAGE)

Step 5

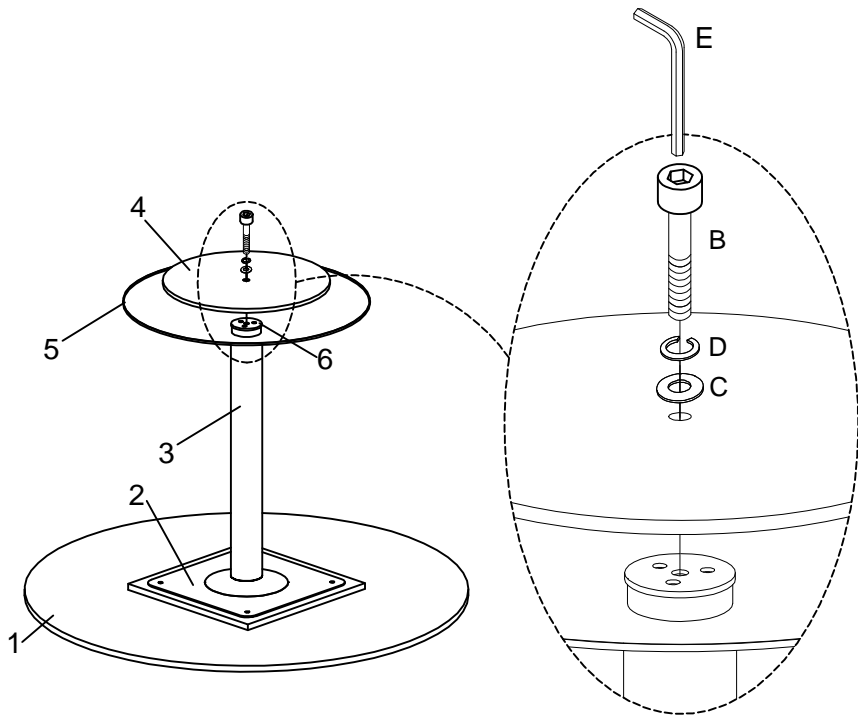



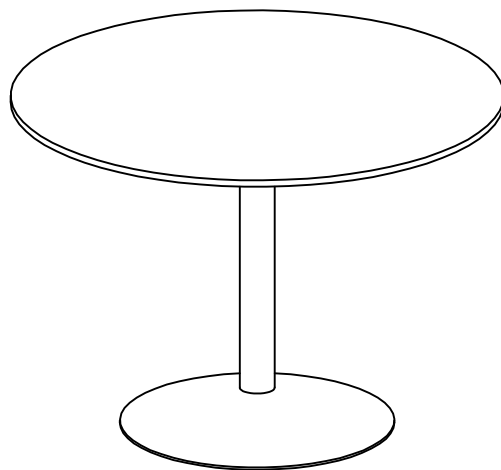

Step 6





ASSEMBLY INSTRUCTIONS (INSTRUCTIONS D'ASSEMBLAGE)

HARDWARE LIST :

NO.	SKETCH	DESCRIPTION	QTY
A		Bolt(5/16"*1-1/4") Boulon	4 PCS
B		Washer(5/16") Rondelle plate	4 PCS
C		Spring washer(5/16") Rondelle frein	4 PCS
D		Allen wrench(5mm)	4 PCS

PARTS LIST :

NO.	SKETCH	DESCRIPTION	QTY
1		Seat Siège	1 PC
2		Leg Pied	2 PCS

Step 1 / Étape 1

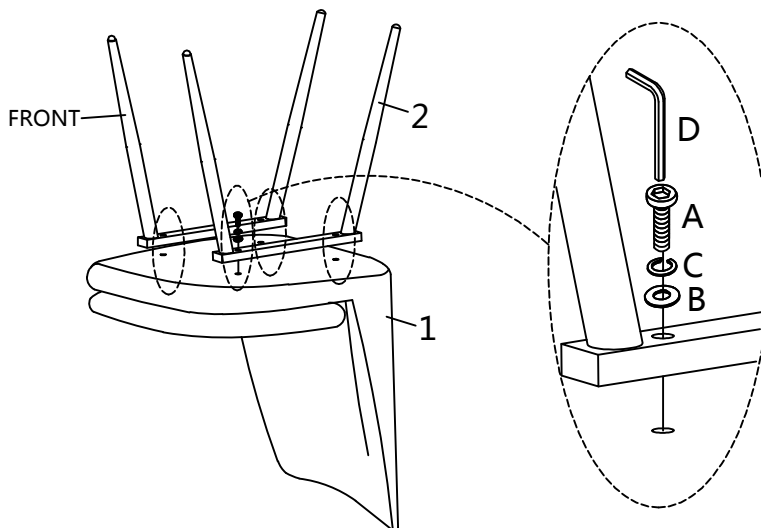

Step 2 / Étape 2

