

ASSEMBLY INSTRUCTIONS NOTICE D'ASSEMBLAGE

Necessary tools/Outils nécessaires

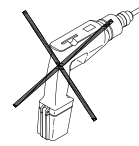
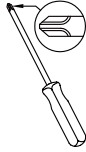
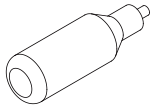

Glue not included (We recommend to apply some glue into holes before inserting wood dowels .)

Colle non inclus (Nous vous recommandons d'appliquer quelques gouttes de colle dans les trous avant d'introduire les chevilles de bois.)

How to use cam lock system/Comment utiliser le système de verrouillage

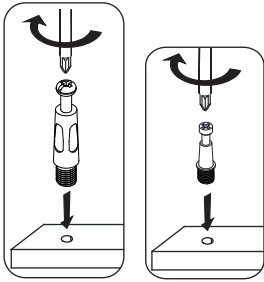

*Screw in cam post and tighten in place.

*Visser le montant de came et serrer en place.

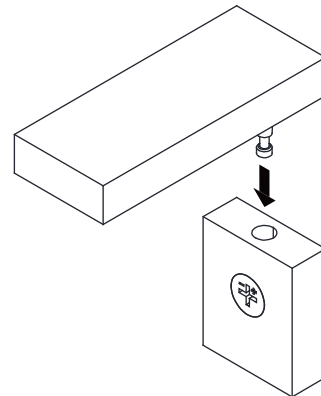
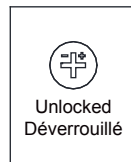
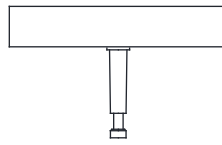

#1
N°1

*Ensure that the cam lock arrow is pointed to the hole, align the cam lock screw to the hole of the cam lock case.

*Assurez-vous que la flèche de verrouillage sur l'écrou de sécurité est orientée vers l'orifice, insérez la vis de verrouillage dans l'orifice.

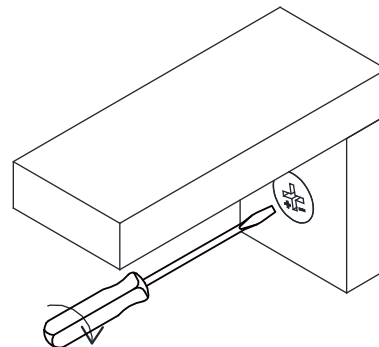

#2
N°2

*Use a straight edge screwdriver to turn cam lock case until it is locked. Locked position is approximately 1/2 turn (210°) clock-wise.

*Utilisez un tournevis ligne droite pour faire tourner l'écrou de sécurité afin de le verrouiller. La position verrouillée est environ 1/2 tour (210°) à la droite.

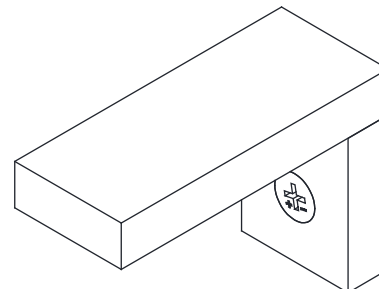
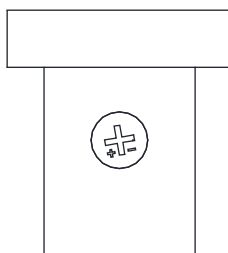

#3
N°3

*After turning the cam lock case to the locked position, the cam lock arrow will be located in the position shown above.

*Après avoir tourné l'écrou de sécurité pour le verrouiller, la flèche de serrure de came se situeront dans la position indiquée ci-dessus.

ASSEMBLY INSTRUCTIONS /
INSTRUCTIONS D'ASSEMBLAGE

ITEM NO/NO ARTICLE: OSCGRFIL/223132

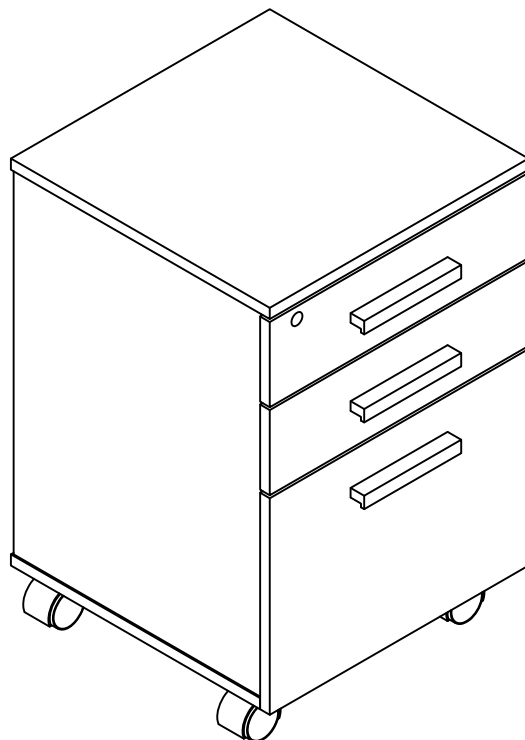

PARTS IDENTIFICATIONS / IDENTIFICATION DES PIECES



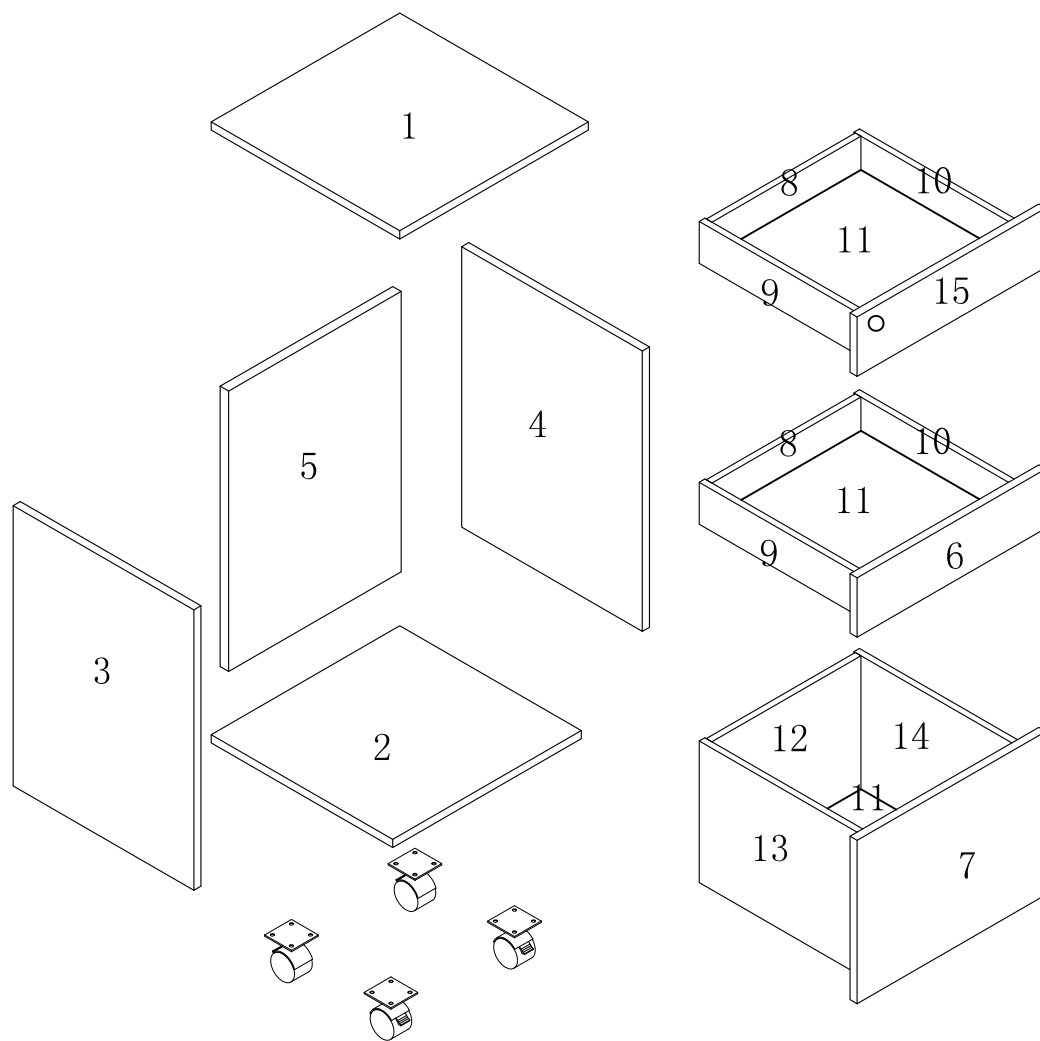







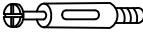

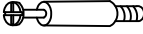
ITEM NO/NO ARTICLE: OSCGRFIL/223132

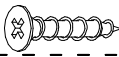

(1)	1pc/pce	(9)	2pcs/pces
(2)	1pc/pce	(10)	2pcs/pces
(3)	1pc/pce	(11)	3pcs/pces
(4)	1pc/pce	(12)	1pc/pce
(5)	1pc/pce	(13)	1pc/pce
(6)	1pc/pce	(14)	1pc/pce
(7)	1pc/pce	(15)	1pc/pce
(8)	2pcs/pces		

HARDWARE IDENTIFICATIONS/ IDENTIFICATION DU KIT D'ASSEMBLAGE

ITEM NO/NO ARTICLE: OSCGRFIL/223132

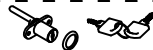
A		L29	12PCS/PCES
B		Φ 15	12PCS/PCES
C		Φ 8x25	8PCS/PCES
D		L20	12PCS/PCES
E		Φ 12	12PCS/PCES
F		Φ 4x40	4PCS/PCES
G		Φ 4x30	14PCS/PCES
H		Φ 6x30	2PCS/PCES
I		Φ 3.5x12	18PCS/PCES
J		96#	3PCS/PCES
K		Φ 4 × 22	6PCS/PCES
L		H55	2PCS/PCES
M		H55	2PCS/PCES
N		□ 5 × 8	2PCS/PCES
O		L326	2PCS/PCES
P			1SET

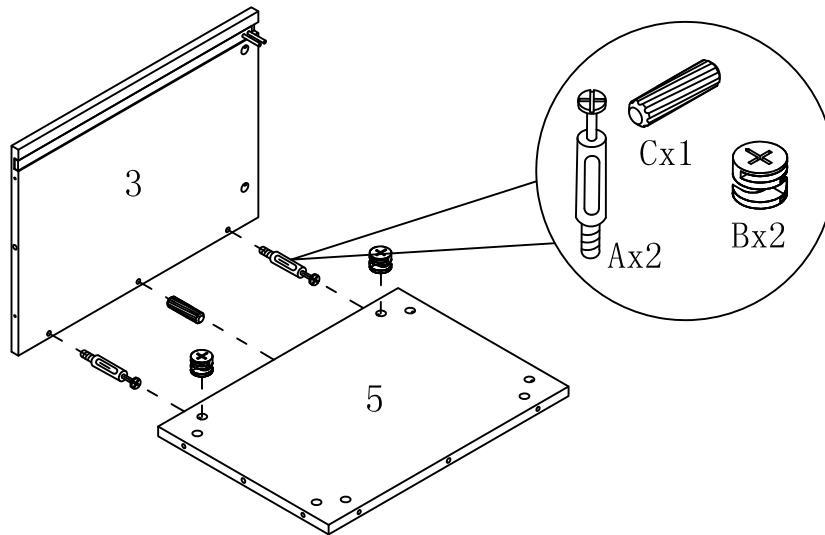

STEP 1 / ETAPE 1

STEP 2 / ETAPE 2

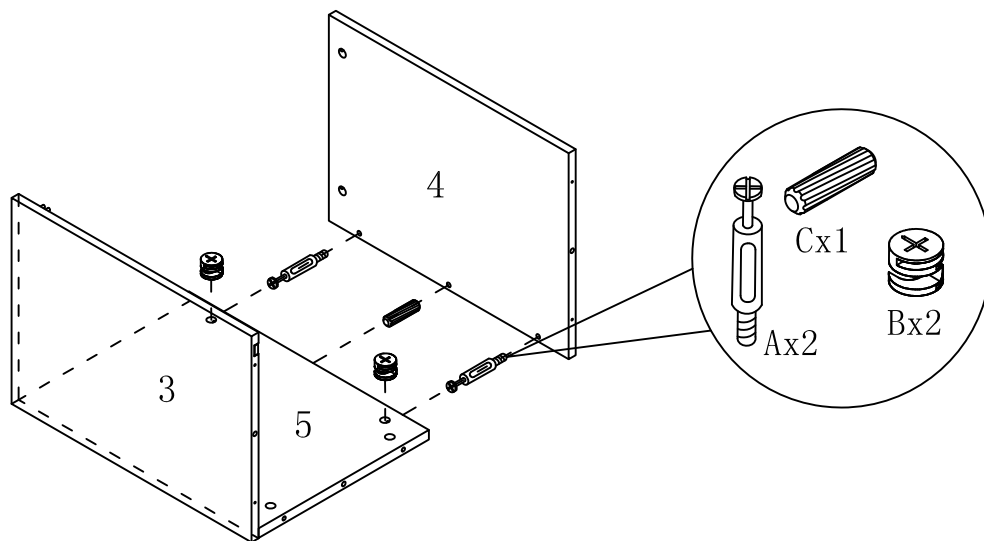

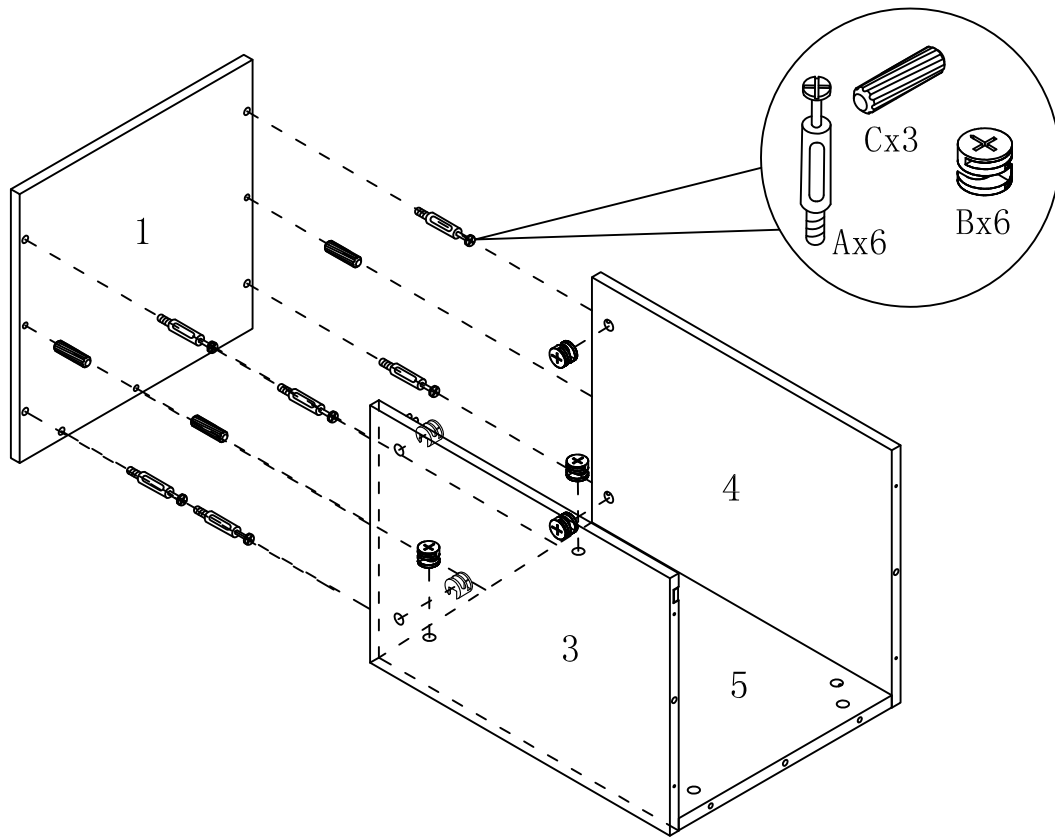

STEP 3 / ETAPE 3

STEP 4 / ETAPE 4

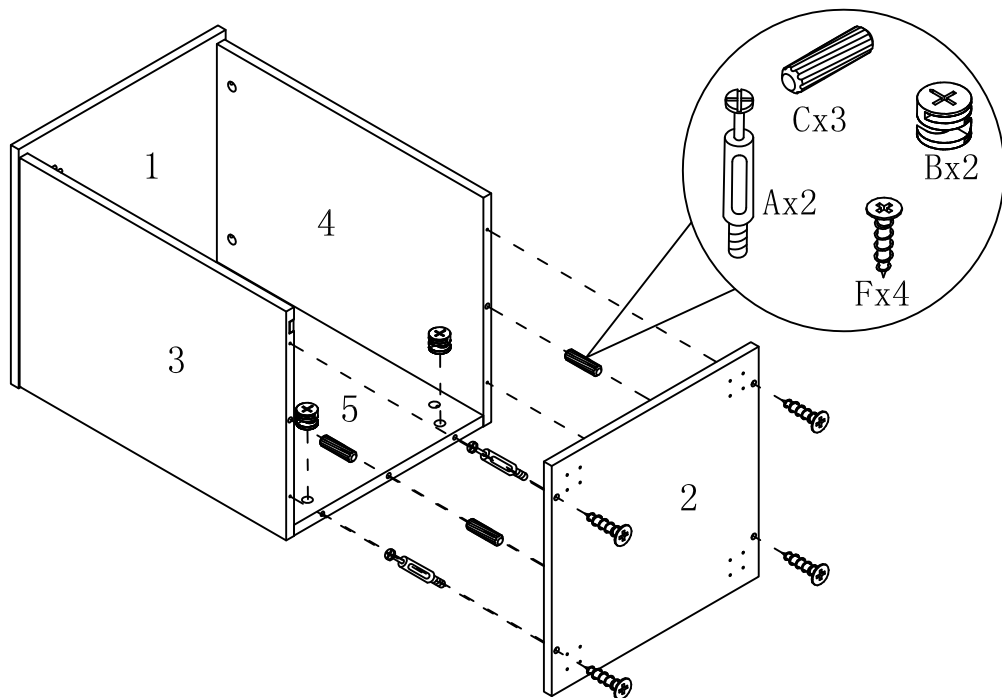

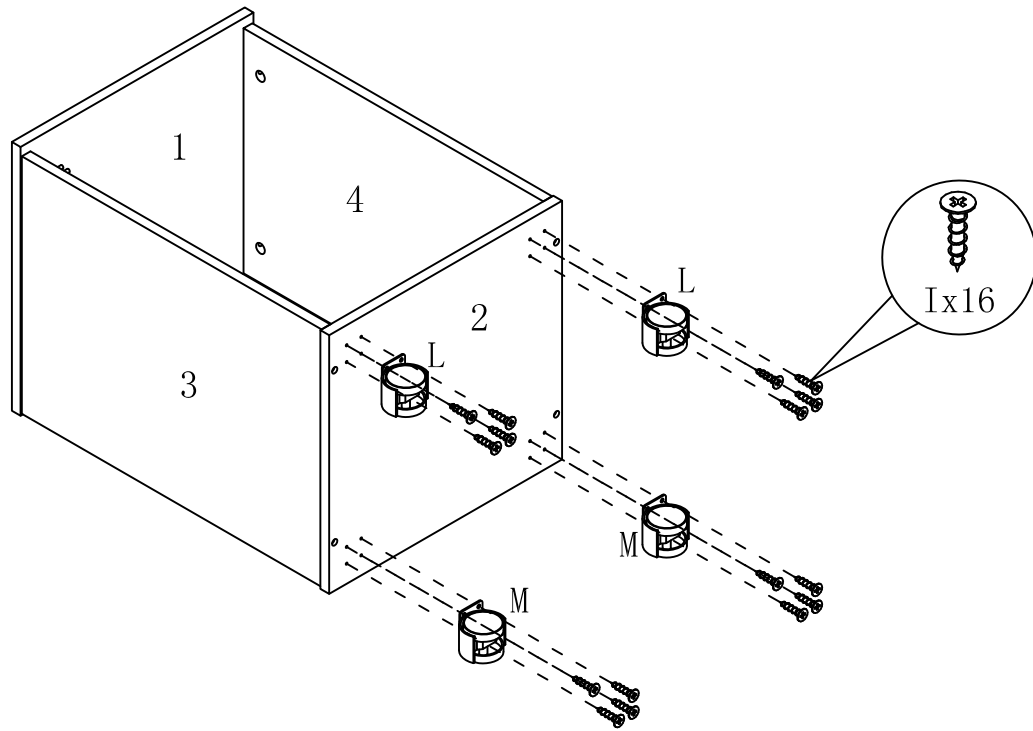

STEP 5 / ETAPE 5

STEP 6 / ETAPE 6

x2

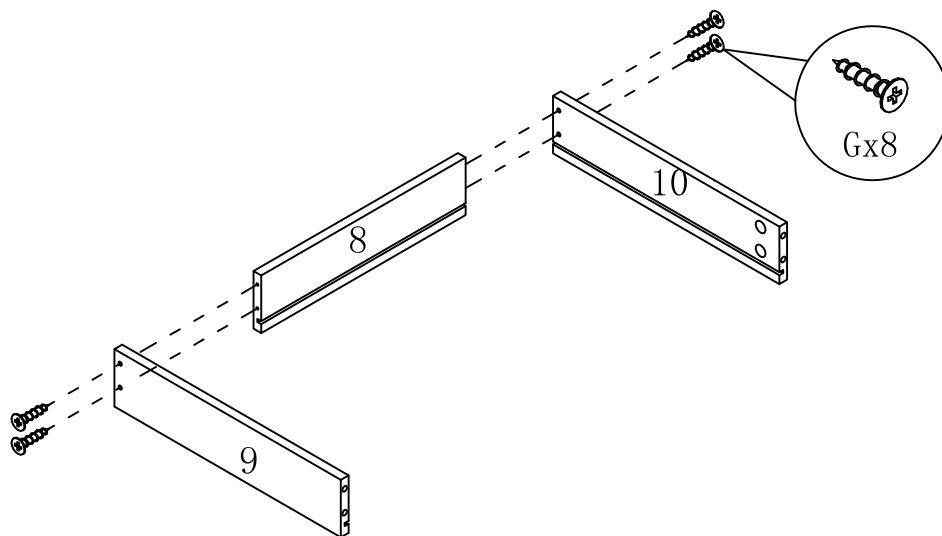

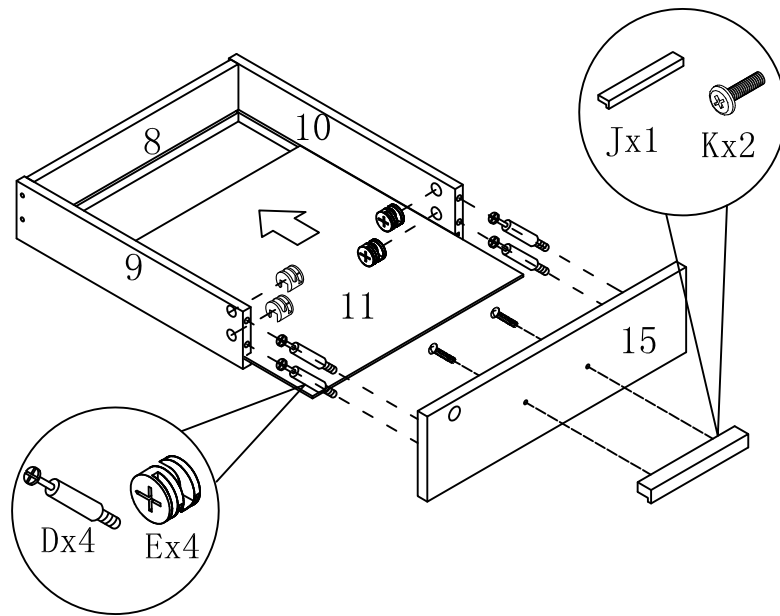

STEP 7 / ETAPE 7

STEP 8 / ETAPE 8

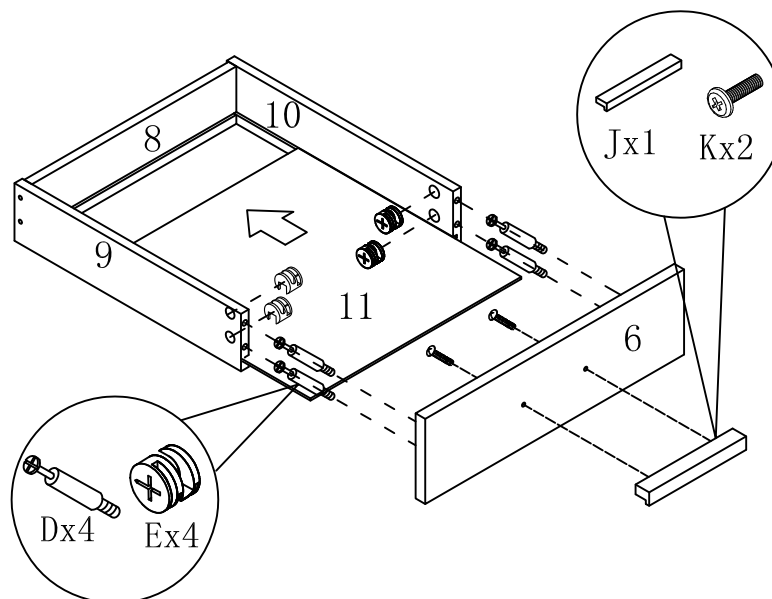

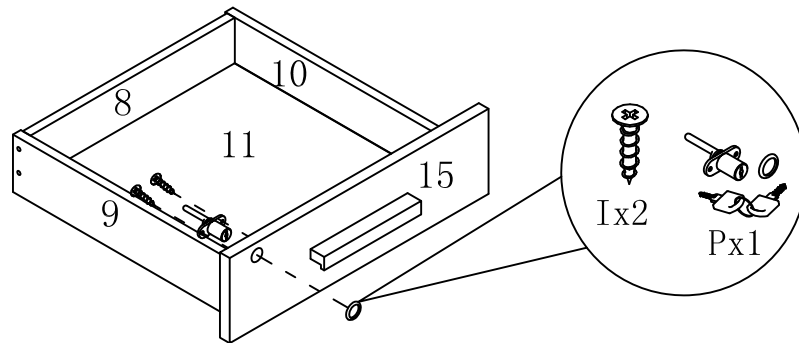

STEP 9 / ETAPE 9

STEP 10 / ETAPE 10

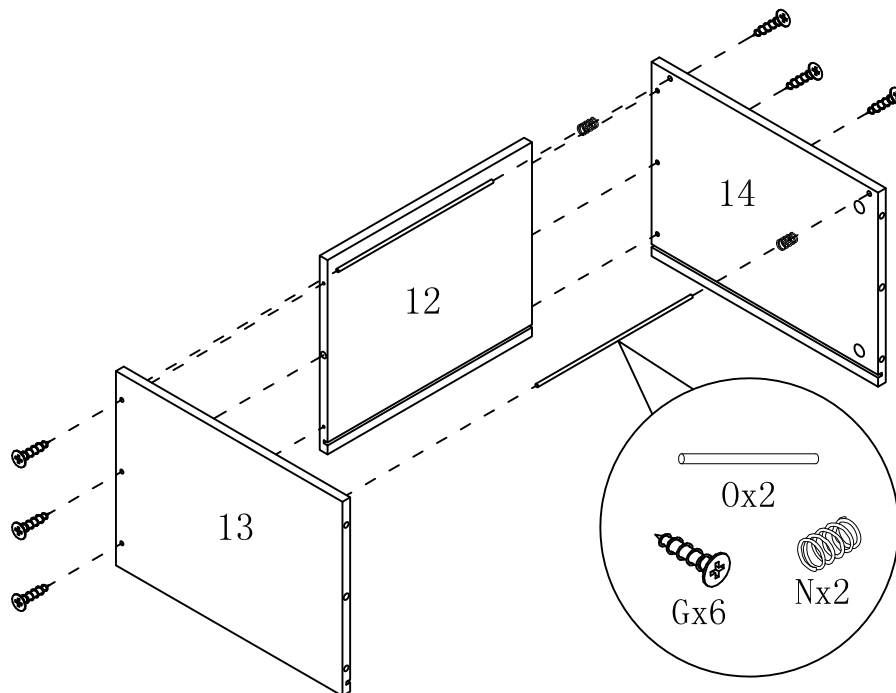

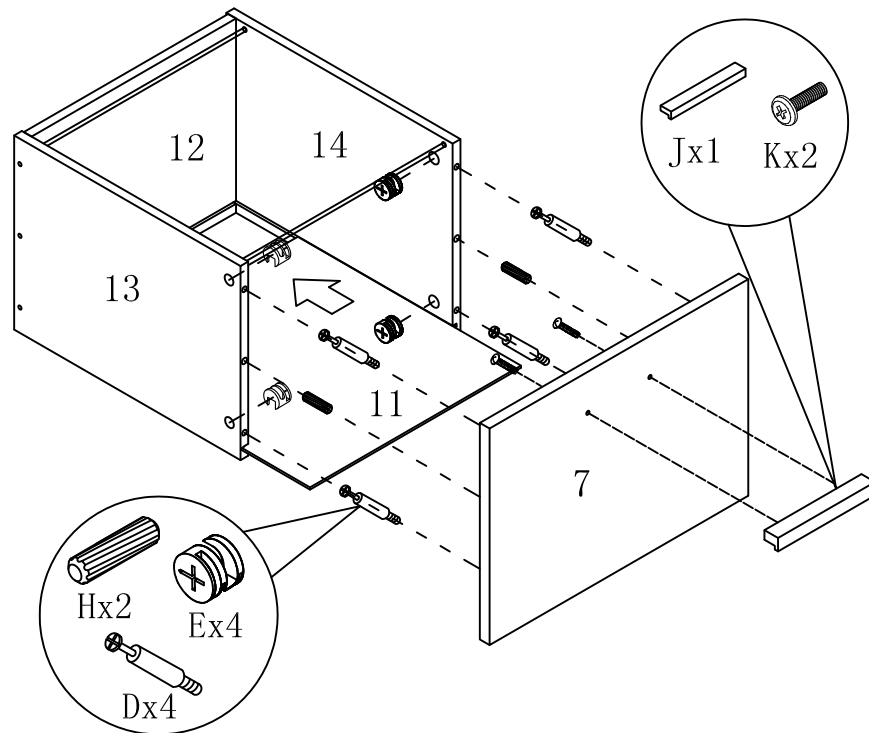

STEP 11 / ETAPE 11

STEP 12 / ETAPE 12

