

ASSEMBLY INSTRUCTIONS (INSTRUCTIONS D'ASSEMBLAGE)

HARDWARE LIST (LISTE DES OUTILS):

NO.	Sketch	Description	Qty
NO.	Schéma	Description	Qté
A		Bolt(1/4"×3/4") Boulon	8 PCS 8 PCES
B		Bolt(1/4"×2-1/8") Boulon	8 PCS 8 PCES
C		Washer(1/4") Rondelle plate	16 PCS 16 PCES
D		Spring Washer(1/4") Rondelle frein	16 PCS 16 PCES
E		Allen wrench(4mm) Clé hexagonale	1 PC 1 PCE

PARTS LIST (LISTE DES PIÉCES):

NO.	Sketch	Description	Qty
NO.	Schéma	Description	Qté
1		Table top Dessus de table	1 PC 1 PCE
2		Leg Pied	4 PCS 4 PCES

Step 1 / Étape 1

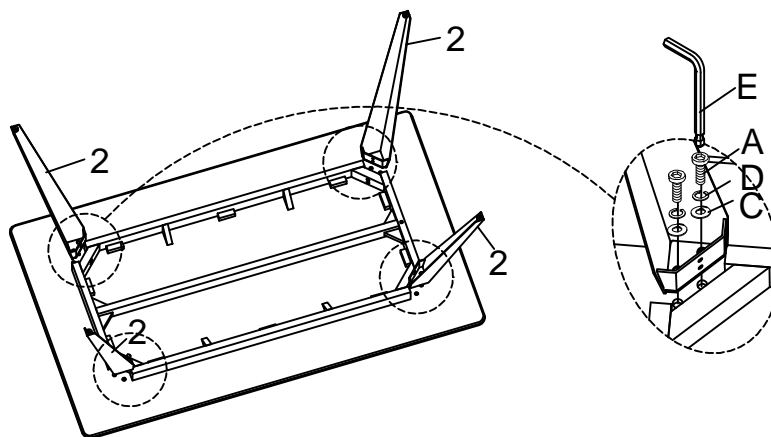

Note: At this stage, do not fully tighten the bolts .

À noter qu'il ne faut pas serrer complètement les boulons à ce stade.

Step 2 / Étape 2

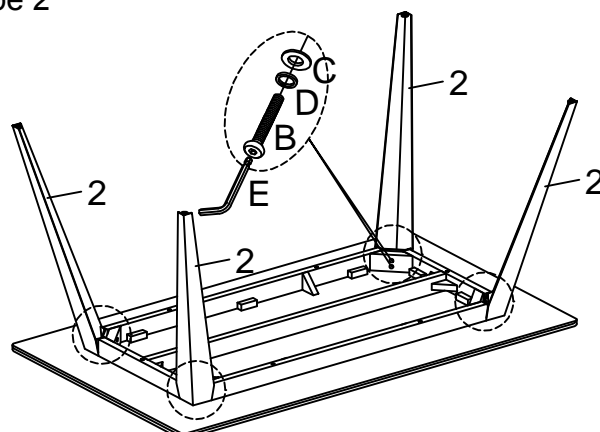

Note: Do not full tighten all bolts until complete assembly.

Tel qu' illustré. Attendre avant de serrer complètement les boulons.

ASSEMBLY INSTRUCTIONS (INSTRUCTIONS D'ASSEMBLAGE)

Step 3 / Étape 3

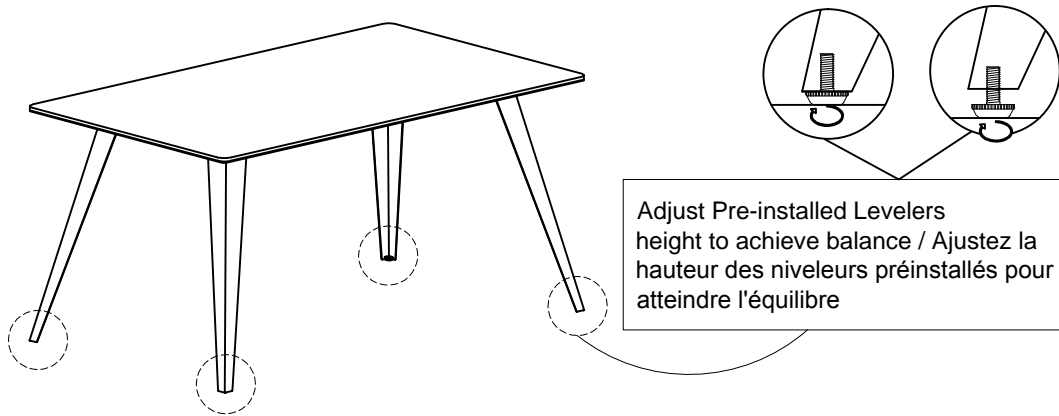

Step 4 / Étape 4

