

# ASSEMBLY INSTRUCTION

FOR C8311A/C8321A CHEST, DRESSER, & NIGHT STAND

## STEP 1

Pull the drawer and take out the Bunfoot carton ( A ).

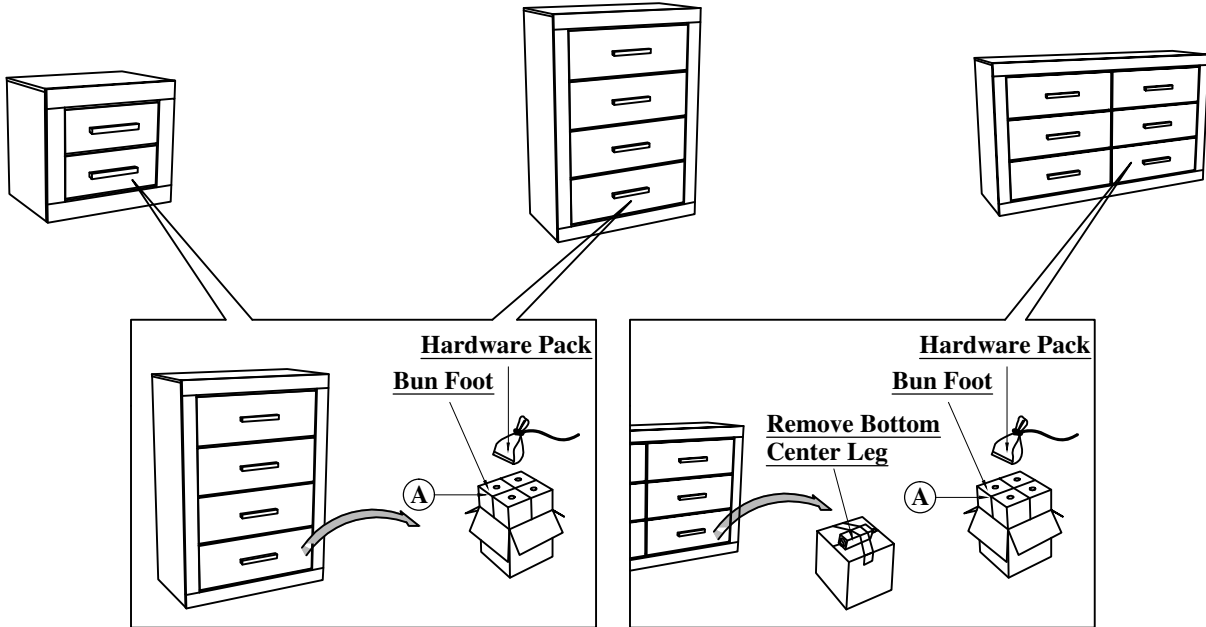



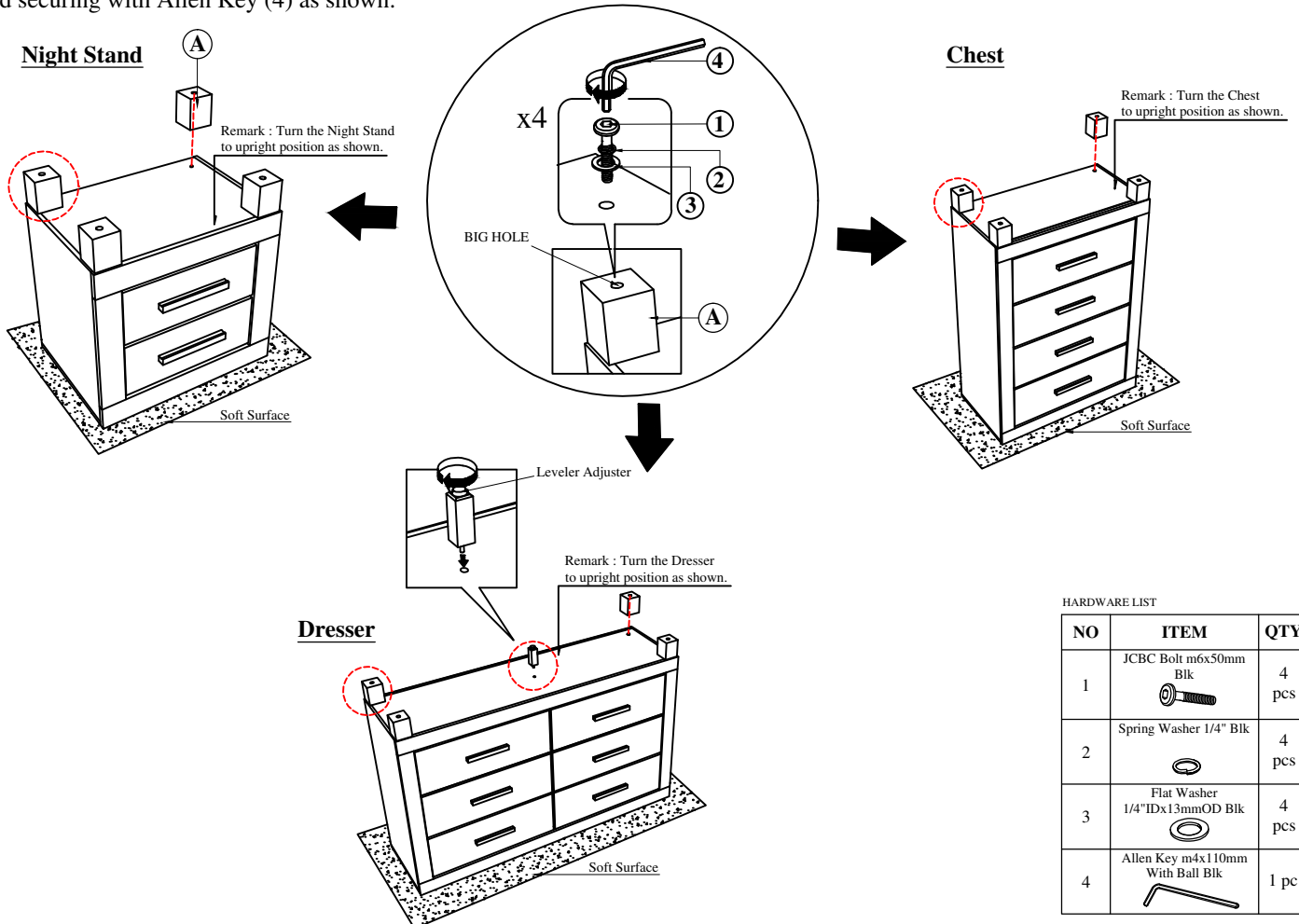

## STEP 2

Assemble the Bun Foot (A) with JCBC Bolt (1), Spring washer (2), Flatwasher (3) and securing with Allen Key (4) as shown.



### HARDWARE LIST

NO	ITEM	QTY
1	JCBC Bolt m6x50mm Blk 	4 pcs
2	Spring Washer 1/4" Blk 	4 pcs
3	Flat Washer 1/4"IDx13mmOD Blk 	4 pcs
4	Allen Key m4x110mm With Ball Blk 	1 pc

# ASSEMBLY INSTRUCTION

**MODEL: C8311A/C8321A  
DRESSER & MIRROR**

**(Box 1)**

BOX OF MIRROR

NO	ITEM	Qty
A	MIRROR	1 PC
B	MIRROR SUPPORT RAIL	2 PCS

**(Box 2)**

BOX OF DRESSER

NO	ITEM	Qty
C	DRESSER	1 PC

**(Box 1)  
HARDWARE LIST**

NO	ITEM	Qty
1	Flat Head Chipboard Screw m4x32mm Rbw	10 PCS

**STEP 1**

Draw out mirror support (B) from the carton box.

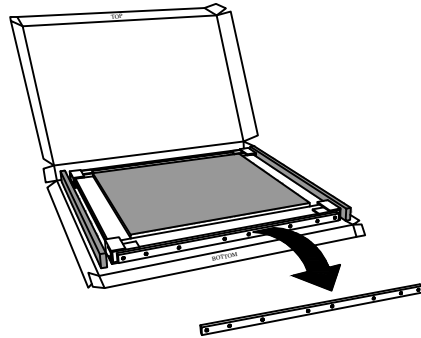

**STEP 2**

Align & fasten mirror support (B) to the back of mirror (A) using Csk Screw (1).  
Note : Make sure the marking of the mirror support (B) must in same level as the bottom frame as shown.  
Secure the Screw by following the holes with indicator number as shown.

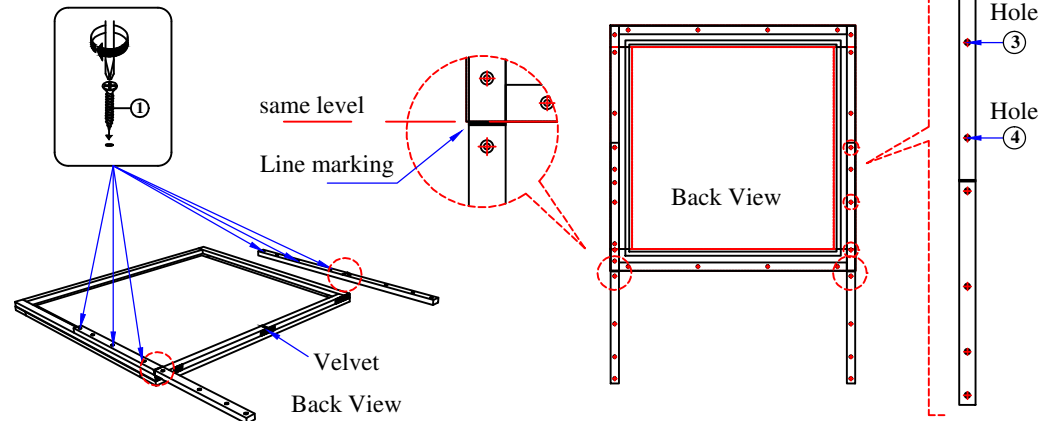

**STEP 3**

Place mirror (A) on top of dresser (C). Align & fasten mirror support (B) to the back of dresser (C) using Csk Screw (1) with Srew with screw driver.(NOT PROVIDED)  
Note : Make sure marking mirror must align with the dresser marking as shown.  
Secure the Screw by following holes with indicator number as shown.

Mirror line marking

Dresser line marking

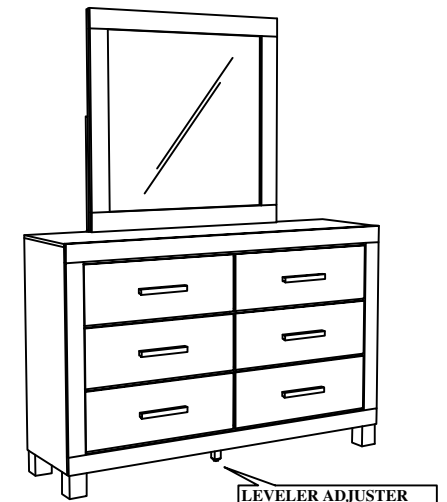
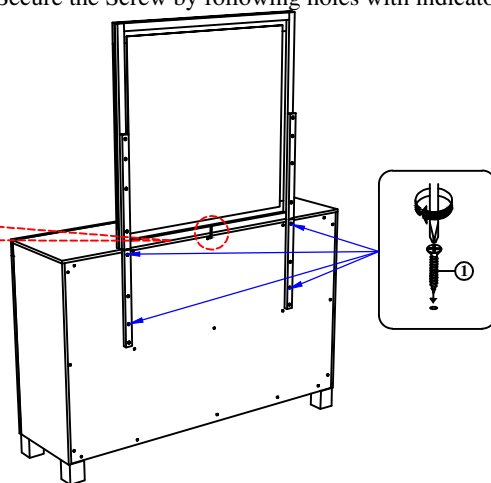
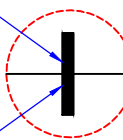

COMPLETED ASSEMBLY

NOTE : MUST TIGHTEN SCREWS PERIODCALLY WITH USE SCREW WILL BECOME LOOSE CHECK TIGHTNESS OF ALL SCREW EVERY 6-8 WEEKS.

# INSTRUCTIONS D'ASSEMBLAGE

POUR C8311A/C8321A POITRINE, COMMODE, & NUIT STAND

## ÉTAPE 1

Tirez le tiroir et sortez le carton de pied (A).

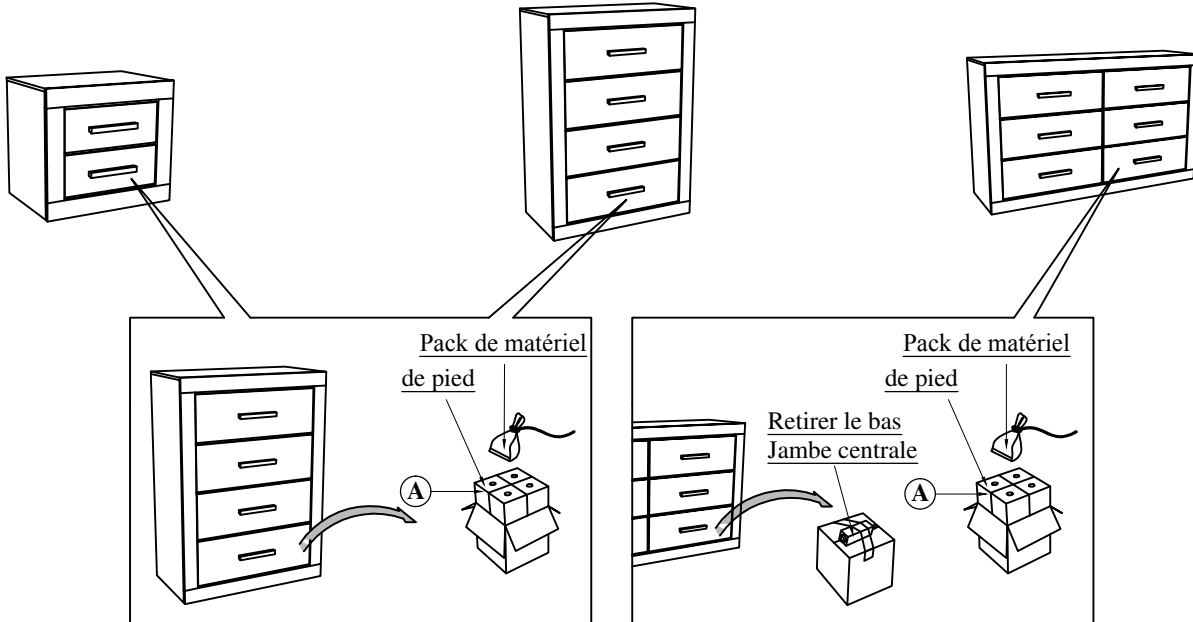



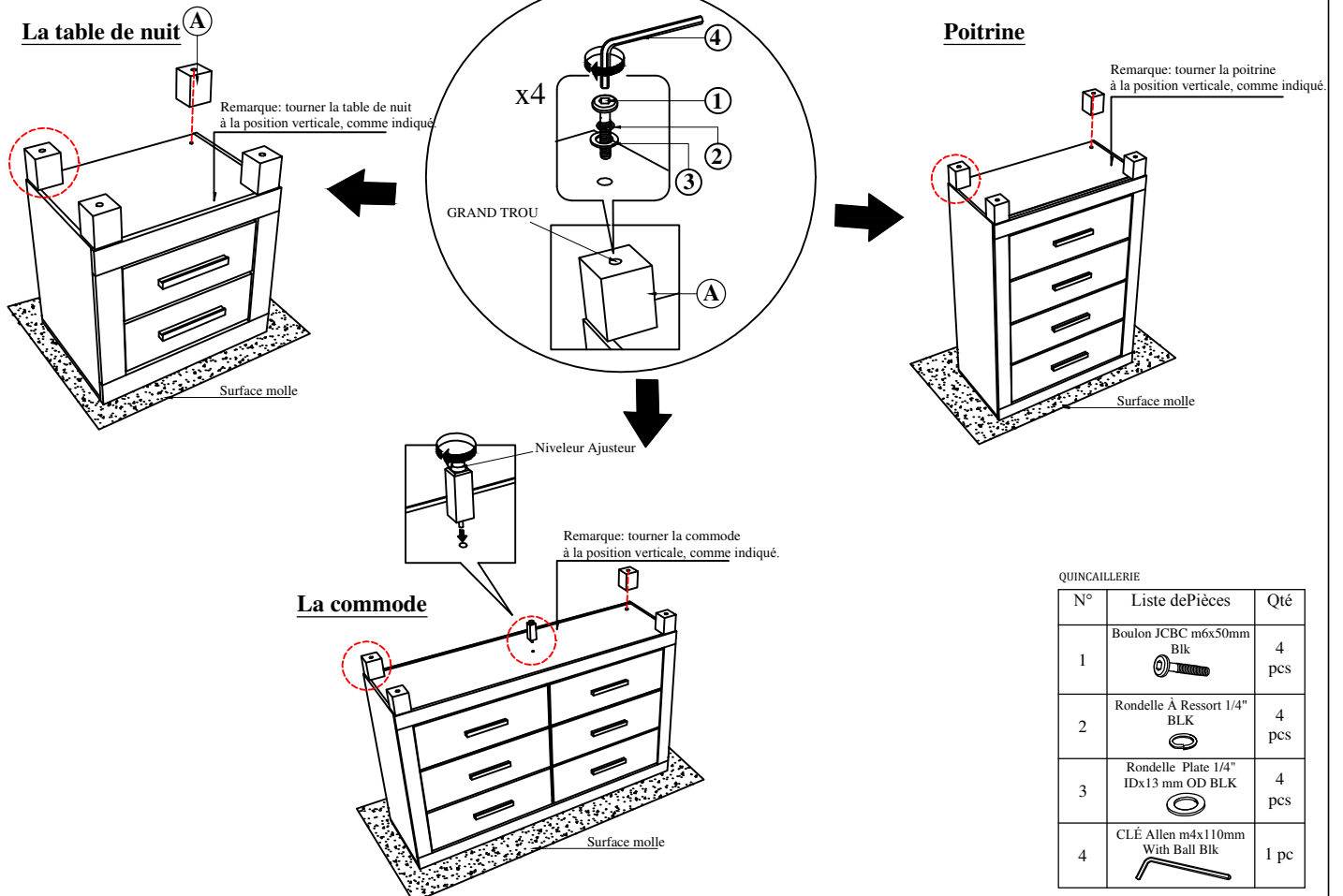

## ÉTAPE 2

Assemblez le pied de brioche (A) avec le boulon JCBC (1), la rondelle élastique (2) et le lave-vaisselle (3) et fixez avec la clé Allen (4) comme indiqué.



### QUINCAILLERIE

N°	Liste de Pièces	Qté
1	Boulon JCBC m6x50mm Blk 	4 pcs
2	Rondelle À Ressort 1/4" BLK 	4 pcs
3	Rondelle Plate 1/4" IDx13 mm OD BLK 	4 pcs
4	CLÉ Allen m4x110mm With Ball Blk 	1 pc

# INSTRUCTIONS D'ASSEMBLAGE

MODÈLE: C8311A/C8321A  
COMMODE & MIROIR

## ÉTAPE 1

Tirez le support de miroir (B) de la boîte en carton.

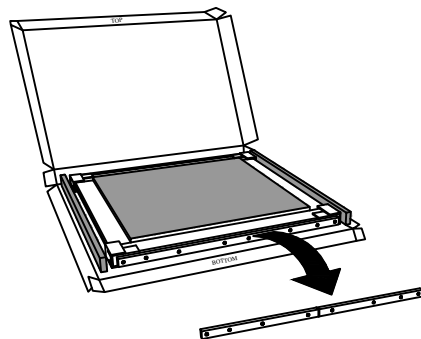

## ÉTAPE 2 : Aligned et fixez le support de miroir (B) à l'arrière du miroir (A) à l'aide de la vis Csk (1).

(1).

Remarque: Assurez-vous que le marquage du support de rétroviseur (B) doit être au même niveau que le cadre inférieur, comme indiqué.

Fixez la vis en suivant les trous avec le numéro de l'indicateur, comme indiqué.

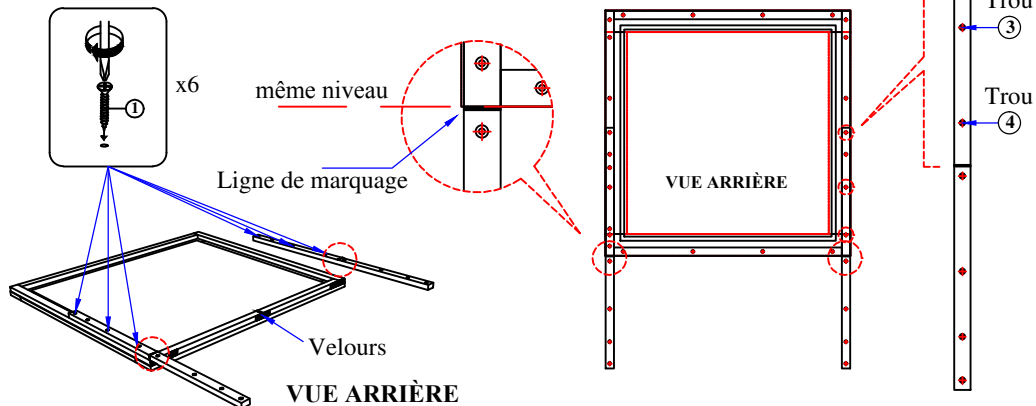

(Cart. 1)

### CARTON MIROIR

N°	Liste de Pièces	Qté
A	MIROIR	1 PCE
B	SOUTIEN DE MIROIR	2 PCES

(Cart. 2)

### CARTON COMMODE

N°	Liste de Pièces	Qté
C	COMMODE	1 PCE

(Cart. 1)

### QUINCAILLERIE

N°	Liste de Pièces	Qté
1	Vis CSK M4 x 32mm	10 PCES

## ÉTAPE 3 : Placez le miroir (A) sur la commode (C). Aligned et fixez le support de rétroviseur (B) sur le dos de la commode (C) à l'aide de la vis Csk (1) avec vis, avec tournevis.

(NONFOURNI) Remarque: assurez-vous que le miroir de marquage doit s'aligner sur la commode marquage comme indiqué.

Fixez la vis en suivant les trous avec le numéro de l'indicateur, comme indiqué.

(NONFOURNI)

Marquage en ligne miroir

Marquage de la ligne de la commode

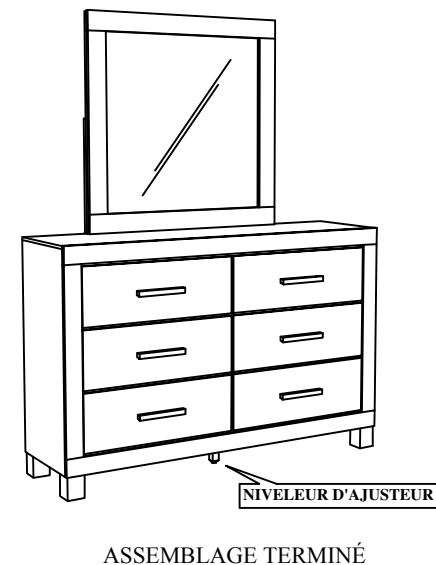
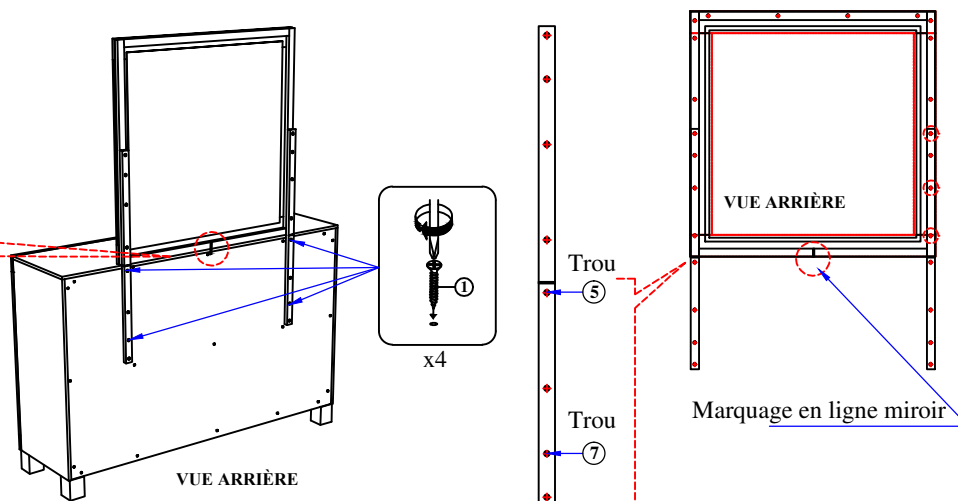

ASSEMBLAGE TERMINÉ

REMARQUE : À L'USAGE, LES VIS SE DESERRENT. VÉRIFIER ET RESSERRER LES VIS TOUTES LES 6-8 SEMAINES.