















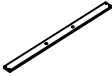



ASSEMBLY INSTRUCTIONS

ITEM NO: C8446A-FY0PUXLGX/C8446A-F24/ C8446A-YXN/ C8446A-TY0PUXLGX/ C8446A-T24
 FULL UPHOLSTERY HEADBOARD/ FULL FOOTBOARD W/ 4 SLATS, 8 SUPPORTS
 TWIN / FULL SIDERAIL SET (2)
 TWIN UPHOLSTERY HEADBOARD/ TWIN FOOTBOARD W/ 4 SLATS, 8 SUPPORTS

Caution: Please read instructions thoroughly before unpacking assembly parts. Sharp, exposed staple tips can cause injury, therefore, for your protection, please remove any exposed staple used in packing.

1. We recommend that you should assemble this product with the assistance of another person; this will make assembly easier, and will help to eliminate damage to the product or injury to persons during assembly.
2. Be sure to check all packing materials carefully for small parts that may have come loose inside the carton during shipment.
3. Please do not over tighten screws or bolts until the assembly is complete.
4. Please put all parts on a non-abrasive floor before assembly, and follow the assembly steps to assemble your newly purchased product correctly and efficiently.

PART LISTS			
NO.	Description	Sketch	Q'ty
A	HEADBOARD		1 PC
B	HEADBOARD LEG (L-R)		2 PCS
C	CROSS BAR		1 PC
D	CRYSTAL & TURNING		4 PCS
E	FOOTBOARD		1 PC
F	LEG		2 PCS
G	SIDERAILS		2 PCS
H	SLATS		4 PCS
I	SUPPORT LEGS		8 PCS

HARDWARE LISTS				
NO.	Description	Sketch	Size	Q'ty
1	BOLT		5/16"x50mm	6 PCS
2	SPRING WASHER		5/16*12*2mm	6 PCS
3	FLAT WASHER		5/16*19*2mm	6 PCS
4	BOLT		1/4"x38mm	2 PCS
5	SPRING WASHER		1/4*10*2mm	2 PCS
6	FLAT WASHER		5/16*19*2mm	2 PCS
7	ALLEN KEY		M4*58mm	1 PC
8	BOLT		ø5/16"*100mm	8 PCS
9	U WASHER		26x12x8mm	8 PCS
10	NUT		ø5/16"x6mm	8 PCS
11	WRENCH		90*25*2mm	1 PC

*ABOVE HARDWARE ARE PACKED IN HEADBOARD FOR ASSEMBLY

12	SCREW		M4x 25mm	16PCS
----	-------	---	----------	-------

*ABOVE HARDWARE ARE PACKED IN FOOTBOARD FOR ASSEMBLY

STEP 1

ASSEMBLY INSTRUCTIONS

ITEM NO: C8446A-FY0PUXLGX/C8446A-F24/ C8446A-YXN/ C8446A-TY0PUXLGX/ C8446A-T24
FULL UPHOLSTERY HEADBOARD/ FULL FOOTBOARD W/ 4 SLATS, 8 SUPPORTS
TWIN / FULL SIDERAIL SET (2)
TWIN UPHOLSTERY HEADBOARD/ TWIN FOOTBOARD W/ 4 SLATS, 8 SUPPORTS

Caution: Please read instructions thoroughly before unpacking assembly parts. Sharp, exposed staple tips can cause injury, therefore, for your protection, please remove any exposed staple used in packing.

1. We recommend that you should assemble this product with the assistance of another person; this will make assembly easier, and will help to eliminate damage to the product or injury to persons during assembly.
2. Be sure to check all packing materials carefully for small parts that may have come loose inside the carton during shipment.
3. Please do not over tighten screws or bolts until the assembly is complete.
4. Please put all parts on a non-abrasive floor before assembly, and follow the assembly steps to assemble your newly purchased product correctly and efficiently.

STEP 1

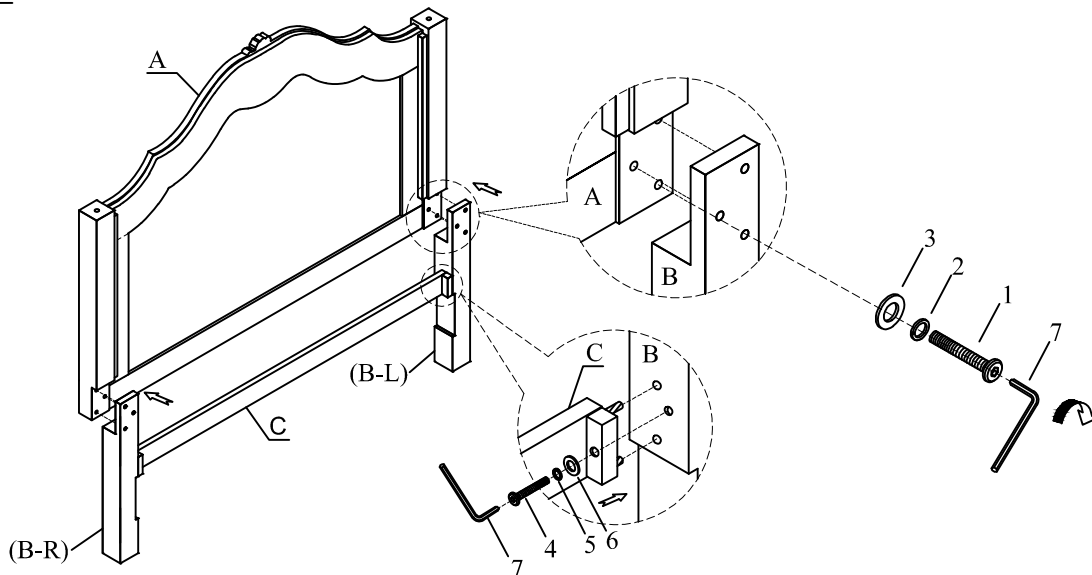

STEP 2

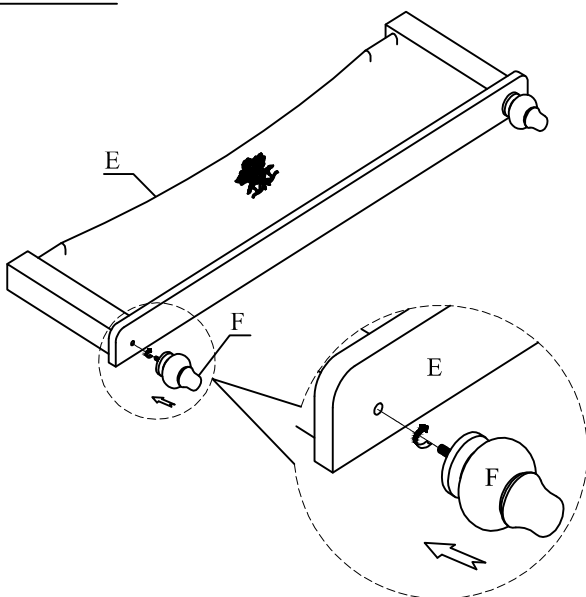

STEP 3

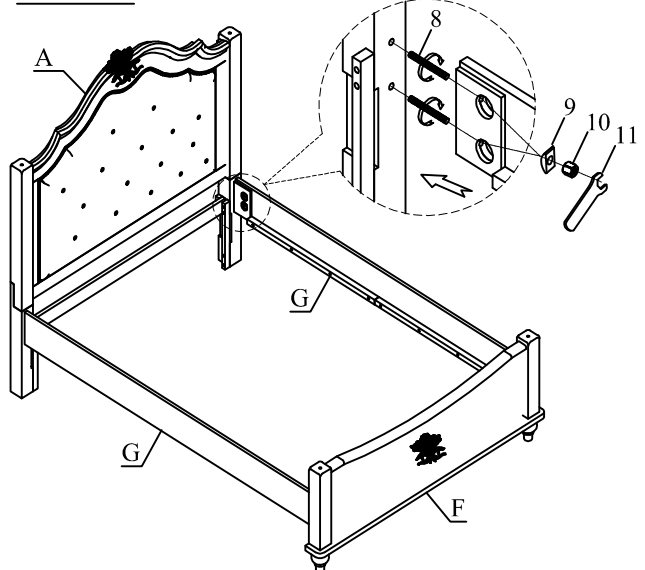

ASSEMBLY INSTRUCTIONS

ITEM NO: C8446A-FY0PUXLGX/C8446A-F24/ C8446A-YXN/ C8446A-TY0PUXLGX/ C8446A-T24
FULL UPHOLSTERY HEADBOARD/ FULL FOOTBOARD W/ 4 SLATS, 8 SUPPORTS
TWIN / FULL SIDERAIL SET (2)
TWIN UPHOLSTERY HEADBOARD/ TWIN FOOTBOARD W/ 4 SLATS, 8 SUPPORTS

Caution: Please read instructions thoroughly before unpacking assembly parts. Sharp, exposed staple tips can cause injury, therefore, for your protection, please remove any exposed staple used in packing.

1. We recommend that you should assemble this product with the assistance of another person; this will make assembly easier, and will help to eliminate damage to the product or injury to persons during assembly.
2. Be sure to check all packing materials carefully for small parts that may have come loose inside the carton during shipment.
3. Please do not over tighten screws or bolts until the assembly is complete.
4. Please put all parts on a non-abrasive floor before assembly, and follow the assembly steps to assemble your newly purchased product correctly and efficiently.

STEP 4

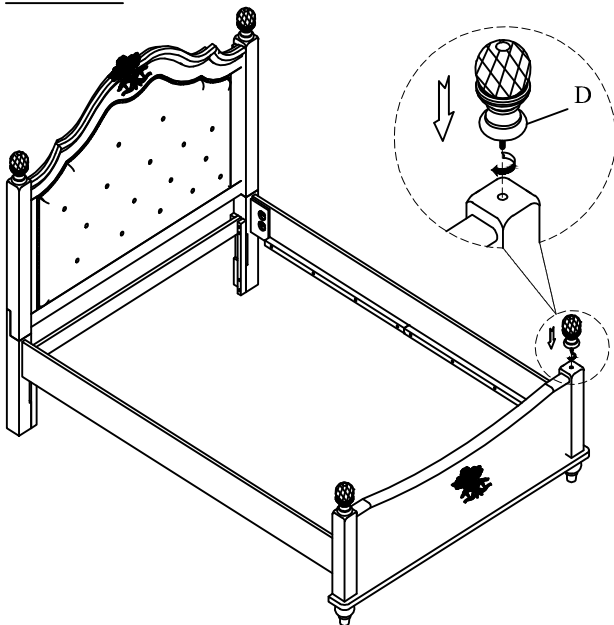

STEP 5

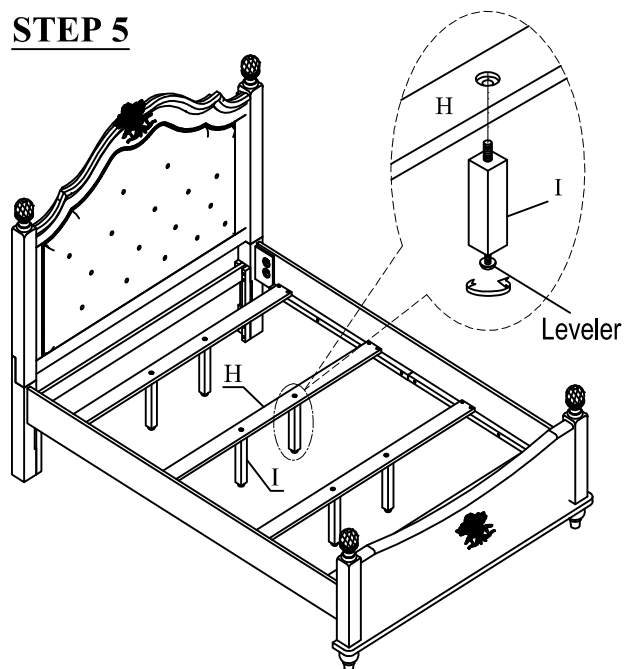

STEP 6

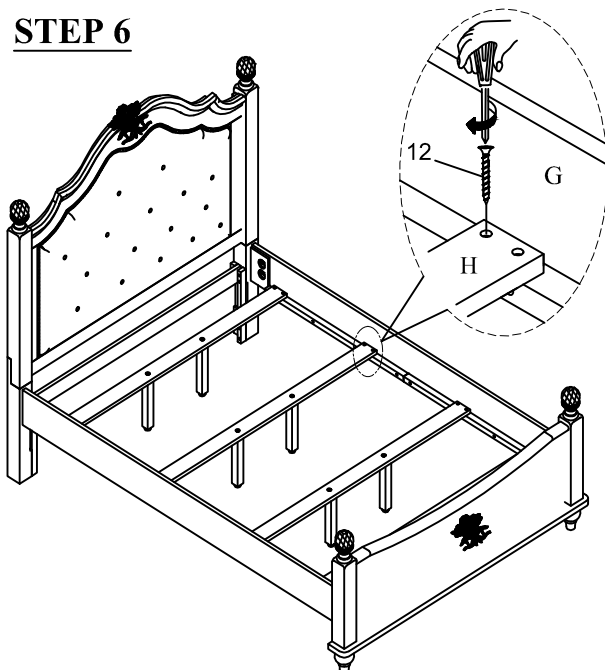

COMPLETED

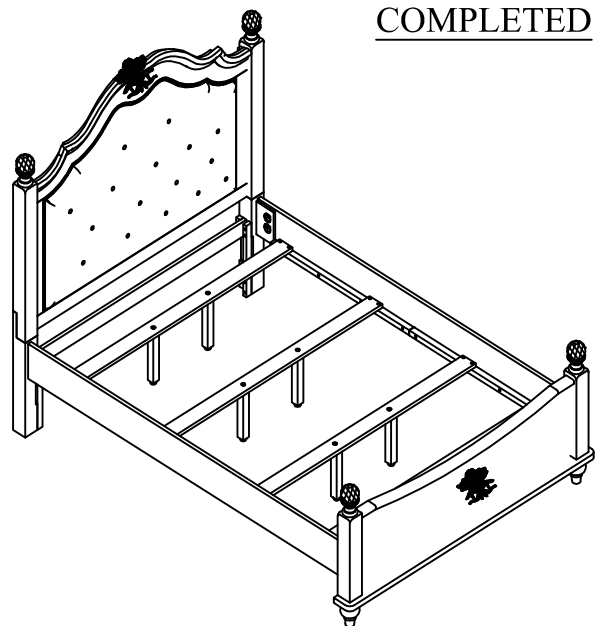

ASSEMBLY INSTRUCTIONS INSTRUCTIONS D'ASSEMBLAGE

ITEM NO/MODELEE N°: LIV2WFHB/ LIV2WFFB/ LIV2WTFR/ LIV2WTHB/ LIV2WTFB

FULL UPHOLSTERY HEADBOARD/ COMPLÈTE TAPISSERIE TÊTE DE LIT

FULL FOOTBOARD W/ 4 SLATS, 4 SUPPORTS/ COMPLET MARCHEPIED AVEC 4 LAMELLES, 4 SUPPORTS









TWIN/FULL SIDERAIL SET (2)/ LIT JUMEAU/LIT COMPLET JEU DE RAILS LATÉRAUX (2)



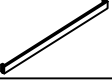



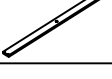





TWIN UPHOLSTERY HEADBOARD/ JUMEAU TAPISSERIE TÊTE DE LIT

TWIN FOOTBOARD W/4 SLATS, 4 SUPPORTS/ LIT JUMEAU MARCHEPIED AVEC 4 LAMELLES, 4 SUPPORTS

Caution: Please read instructions thoroughly before unpacking assembly parts. Sharp, exposed staple tips can cause injury, therefore, for your protection, please remove any exposed staple used in packing./ Attention : Lire toutes les instructions avant de déballer les pièces. Les agrafes en partie dé couvertes peuvent être dangereuses. Retirer de l'emballage toutes les agrafes présentant un risque.

1. We recommend that you should assemble this product with the assistance of another person; this will make assembly easier, and will help to eliminate damage to the product or injury to persons during assembly./ 1. Monter ce produit avec l'aide d'une seconde personne pour faciliter l'assemblage, protéger le produit et éviter tout risque de blessure.
2. Be sure to check all packing materials carefully for small parts that may have come loose inside the carton during shipment./ 2. Vérifier tous les paquets d'emballage. Certaines petites pièces peuvent s'être échappées de leur emballage durant le transport.
3. Please do not over tighten screws or bolts until the assembly is complete./ 3. Ne pas serrer trop les vis et boulons avant que l'assemblage sera terminé.
4. Please put all parts on a non-abrasive floor before assembly, and follow the assembly steps to assemble your newly purchased product correctly and efficiently./ 4. Pour un résultat optimal, disposer tous les éléments sur une surface non-râpeuse avant l'assemblage, et suivre chaque étape du montage avec attention.

PART LISTS/ PIÈCES			
No./ N°	Description/ Description	Sketch/ Illustration	Q'ty/ Qté
A	Headboard Panel/ Tête de Lit		1 Pc/Pce
B	Headboard Leg (L-R)/ Pied de tête de lit		2 Pcs/Pces
C	Cross Bar/ Barre transversale		1 Pc/Pce
D	Crystal & Turning/ Cristal et tournage		4 Pcs/Pces
E	Footboard Panel/ Pied de Lit		1 Pc/Pce
F	Bun Foot/ Pied Boule		2 Pcs/Pces
G	Bed Side Rails/ Longerons		2 Pcs/Pces
H	Slats/ Lattes		4 Pcs/Pces
I	Slat Support Legs/ Pieds Soutien Lattes		4 Pcs/Pces

HARDWARE LISTS/ QUINCAILLERIE				
No./ N°	Description/ Description	Sketch/ Illustration	Size/ Taille	Q'ty/ Qté
1	Allen Bolt/ Boulon Hex		5/16"x50mm	6 Pcs/Pces
2	Spring Washer/ Rondelle à Ressort		5/16*12*2mm	6 Pcs/Pces
3	Flat Washer/ Rondelle Plate		5/16*19*2mm	6 Pcs/Pces
4	Allen Bolt/ Boulon Hex		1/4"x38mm	2 Pcs/Pces
5	Spring Washer/ Rondelle à Ressort		1/4*10*2mm	2 Pcs/Pces
6	Flat Washer/ Rondelle Plate		5/16*19*2mm	2 Pcs/Pces
7	Allen Key/ Clé Allen		M4*58mm	1 Pc/Pce
8	Bolt/ Boulon		ø5/16"*100mm	8 Pcs/Pces
9	U Washer/ Rondelle en U		26x12x8mm	8 Pcs/Pces
10	Nut/ Écrou		ø5/16"x6mm	8 Pcs/Pces
11	Wrench/ Clé		90*25*2mm	1 Pc/Pce
*ABOVE HARDWARE ARE PACKED IN HEADBOARD FOR ASSEMBLY/ *LA QUINCAILLERIE CI-DESSUS SONT EMBALLÉS DANS LA TÊTE DE LIT POUR L'ASSEMBLAGE				
12	Screw/ Vis		M4x 25mm	8 Pcs/Pces

*ABOVE HARDWARE ARE PACKED IN FOOTBOARD FOR ASSEMBLY/ *LA QUINCAILLERIE CI-DESSUS SONT EMBALLÉS DANS DES PIEDS POUR L'ASSEMBLAGE

ASSEMBLY INSTRUCTIONS INSTRUCTIONS D'ASSEMBLAGE

ITEM NO/MODELEE N°: LIV2WFHB/ LIV2WFFB/ LIV2WTFR/ LIV2WTHB/ LIV2WTFB

FULL UPHOLSTERY HEADBOARD/ COMPLÈTE TAPISSERIE TÊTE DE LIT

FULL FOOTBOARD W/ 4 SLATS, 4 SUPPORTS/ COMPLET MARCHEPIED AVEC 4 LAMELLES, 4 SUPPORTS

TWIN/FULL SIDERAIL SET (2)/ LIT JUMEAU/LIT COMPLET JEU DE RAILS LATÉRAUX (2)

TWIN UPHOLSTERY HEADBOARD/ JUMEAU TAPISSERIE TÊTE DE LIT

TWIN FOOTBOARD W/4 SLATS, 4 SUPPORTS/ LIT JUMEAU MARCHEPIED AVEC 4 LAMELLES, 4 SUPPORTS

Caution: Please read instructions thoroughly before unpacking assembly parts. Sharp, exposed staple tips can cause injury, therefore, for your protection, please remove any exposed staple used in packing./ Attention : Lire toutes les instructions avant de déballer les pièces. Les agrafes en partie dé couvertes peuvent être dangereuses. Retirer de l'emballage toutes les agrafes présentant un risque.

1. We recommend that you should assemble this product with the assistance of another person; this will make assembly easier, and will help to eliminate damage to the product or injury to persons during assembly./ 1. Monter ce produit avec l'aide d'une seconde personne pour faciliter l'assemblage, protéger le produit et éviter tout risque de blessure.
2. Be sure to check all packing materials carefully for small parts that may have come loose inside the carton during shipment./ 2. Vérifier tous les paquets d'emballage. Certaines petites pièces peuvent s'être échappées de leur emballage durant le transport.
3. Please do not over tighten screws or bolts until the assembly is complete./ 3. Ne pas serrer trop les vis et boulons avant que l'assemblage sera terminé.
4. Please put all parts on a non-abrasive floor before assembly, and follow the assembly steps to assemble your newly purchased product correctly and efficiently./ 4. Pour un résultat optimal, disposer tous les éléments sur une surface non-râpeuse avant l'assemblage, et suivre chaque étape du montage avec attention.

Step 1 Étape 1

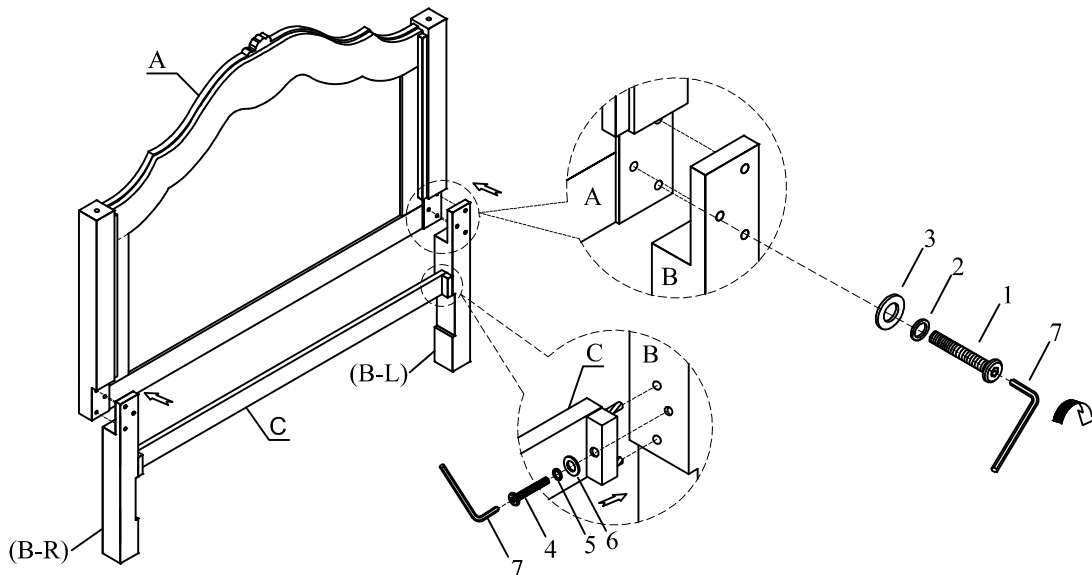

Step 2 Étape 2

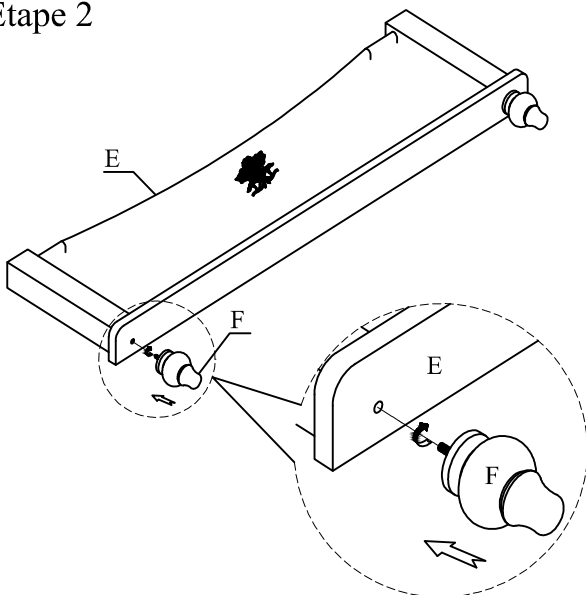

Step 3 Étape 3

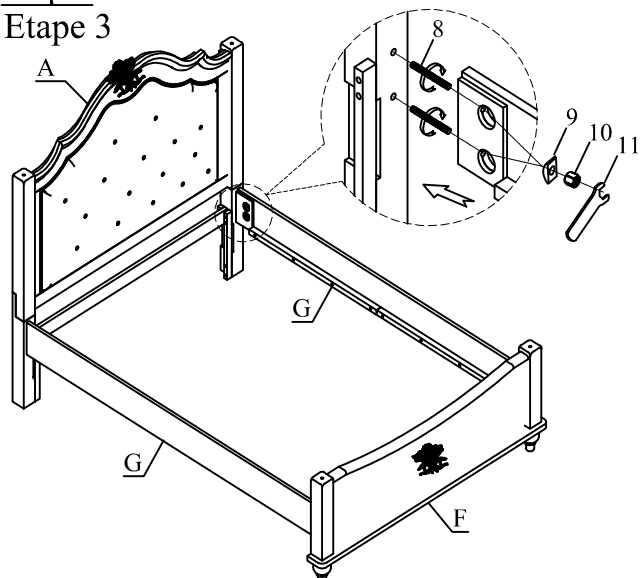

ASSEMBLY INSTRUCTIONS INSTRUCTIONS D'ASSEMBLAGE

ITEM NO/MODELEE N°: LIV2WFHB/ LIV2WFFB/ LIV2WTFR/ LIV2WTHB/ LIV2WTFB

FULL UPHOLSTERY HEADBOARD/ COMPLÈTE TAPISSERIE TÊTE DE LIT

FULL FOOTBOARD W/ 4 SLATS, 4 SUPPORTS/ COMPLET MARCHEPIED AVEC 4 LAMELLES, 4 SUPPORTS

TWIN/FULL SIDERAIL SET (2)/ LIT JUMEAU/LIT COMPLET JEU DE RAILS LATÉRAUX (2)

TWIN UPHOLSTERY HEADBOARD/ JUMEAU TAPISSERIE TÊTE DE LIT

TWIN FOOTBOARD W/4 SLATS, 4 SUPPORTS/ LIT JUMEAU MARCHEPIED AVEC 4 LAMELLES, 4 SUPPORTS

Caution: Please read instructions thoroughly before unpacking assembly parts. Sharp, exposed staple tips can cause injury, therefore, for your protection, please remove any exposed staple used in packing./ Attention : Lire toutes les instructions avant de déballer les pièces. Les agrafes en partie dé couvertes peuvent être dangereuses. Retirer de l'emballage toutes les agrafes présentant un risque.

1. We recommend that you should assemble this product with the assistance of another person; this will make assembly easier, and will help to eliminate damage to the product or injury to persons during assembly./ 1. Monter ce produit avec l'aide d'une seconde personne pour faciliter l'assemblage, protéger le produit et éviter tout risque de blessure.
2. Be sure to check all packing materials carefully for small parts that may have come loose inside the carton during shipment./ 2. Vérifier tous les paquets d'emballage. Certaines petites pièces peuvent s'être échappées de leur emballage durant le transport.
3. Please do not over tighten screws or bolts until the assembly is complete./ 3. Ne pas serrer trop les vis et boulons avant que l'assemblage sera terminé.
4. Please put all parts on a non-abrasive floor before assembly, and follow the assembly steps to assemble your newly purchased product correctly and efficiently./ 4. Pour un résultat optimal, disposer tous les éléments sur une surface non-râpeuse avant l'assemblage, et suivre chaque étape du montage avec attention.

Step 4 Etape 4

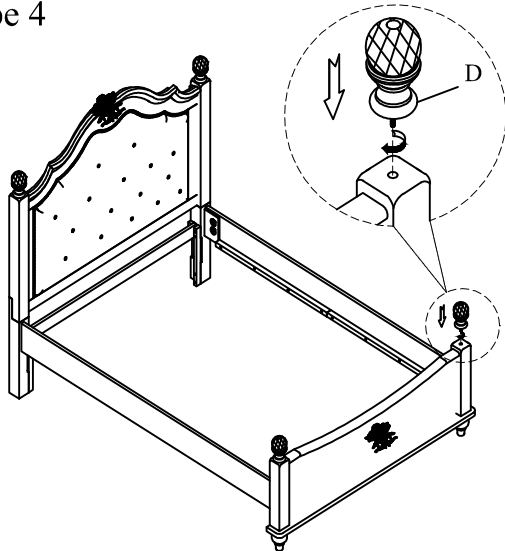

Step 5 Etape 5

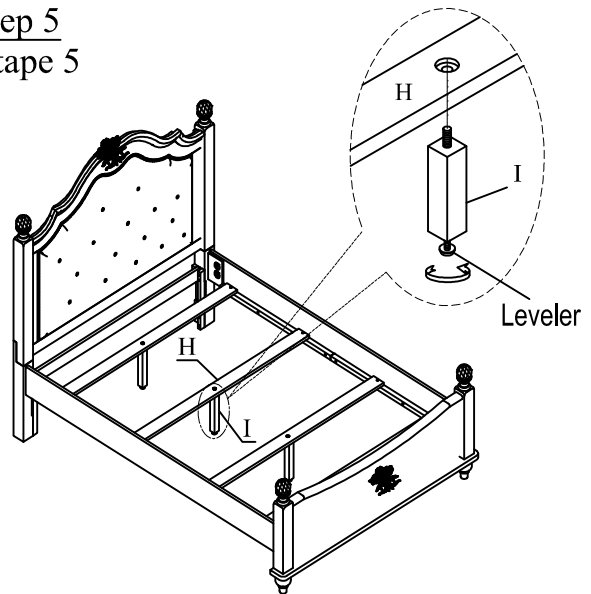

Step 6 Etape 6

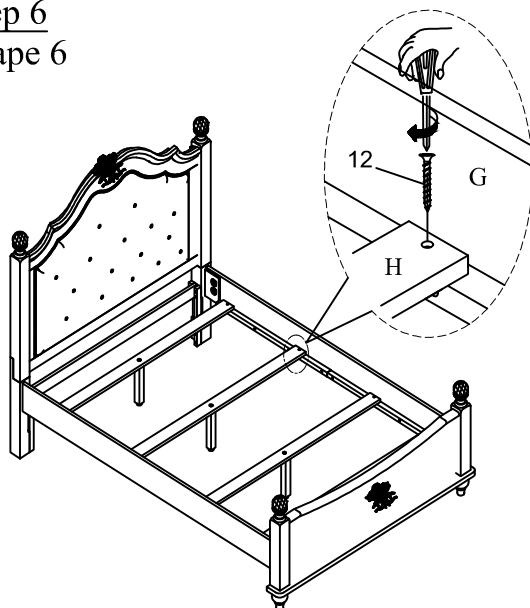

Completed Terminé

