

# ASSEMBLY INSTRUCTIONS / NOTICE D'ASSEMBLAGE

## ITEM : JYP-1213C1/DECBRCTB

### Important note/ Note importante:

1. Place all wooden parts on a clean and smooth surface such as a rug or carpet to avoid scratching the parts. / Placer les pièces sur une surface propre et lisse tel qu'une couverture ou un tapis pour éviter d'endommager les pièces.
2. Kindly follow the assembly instructions step by step./ Veuillez suivre la notice d'assemblage, pas à pas.
3. Do not tighten all screws and bolts until the table is fully assembled./ Ne serrer les vis et boulons à fond que lorsque le produit est entièrement assemblé.
4. Unscrew the protective plastic supports from the metal insert of the table legs before assembly./ Dévisser les caches plastiques des embouts métalliques des pieds de la table avant l'assemblage.

### PARTS IDENTIFICATION / IDENTIFICATION DES PIÈCES

**A** Table Top  
Dessus de Table

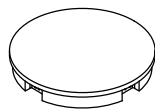

1pc

**B** Base plate  
Plaque de base

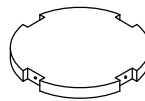

1pc

**C** Leg  
Pied



4pcs

### HARDWARE IDENTIFICATION / IDENTIFICATION DES PIÈCES MONTAGE

**1** Bolt  
Boulon

Ø1/4"x45mm



12pcs

**2** Spring Washer  
Rondelle D'arret

Ø1/4"x11mm

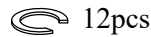

12pcs

**3** Flat Washer  
Rondelle Plate

Ø1/4"x19mm



12pcs

**4** Allen Key  
Clé Allen

M4

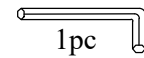

1pc

### STEP 1 / ÉTAPE 1

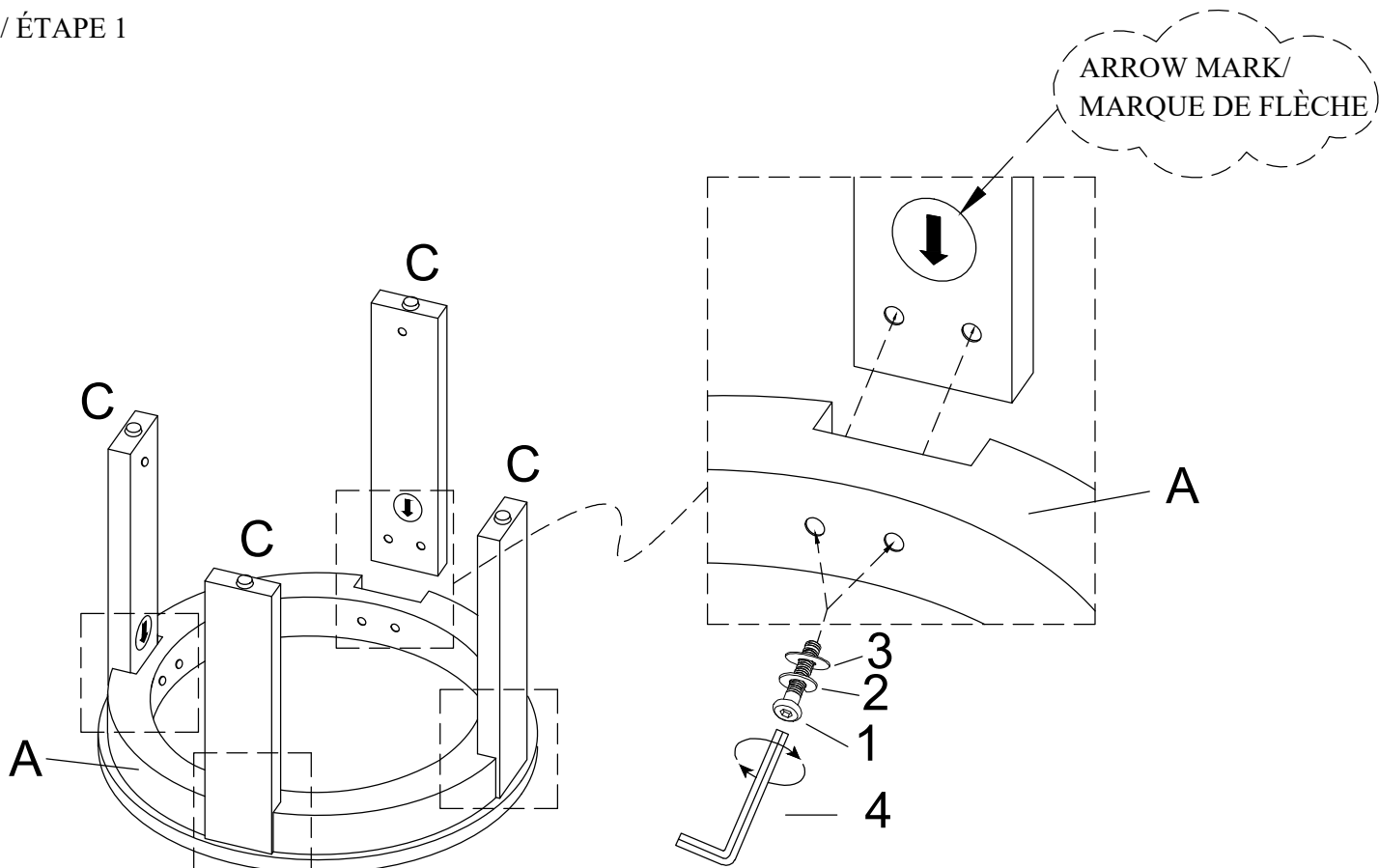

# ASSEMBLY INSTRUCTIONS / NOTICE D'ASSEMBLAGE

## ITEM : JYP-1213C1/DECBRCTB

### STEP 2 / ÉTAPE 2

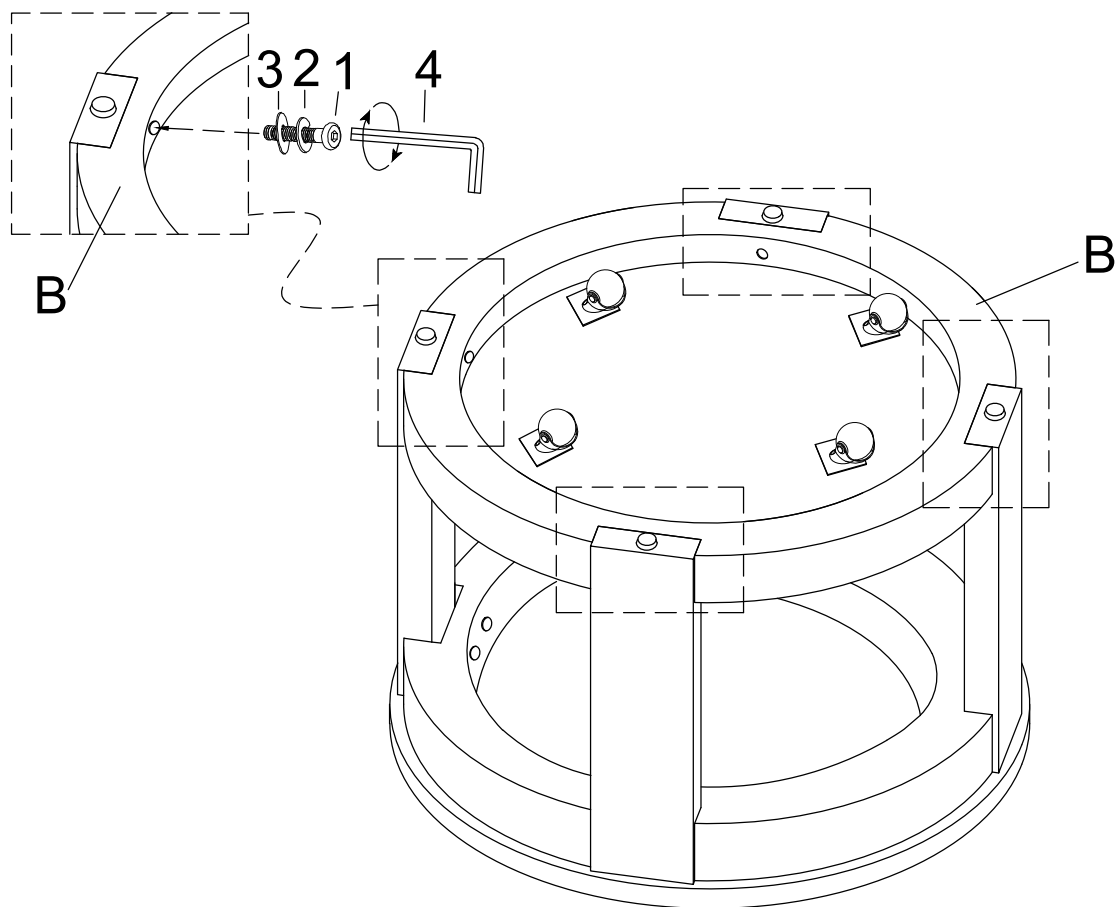

### COMPLETED

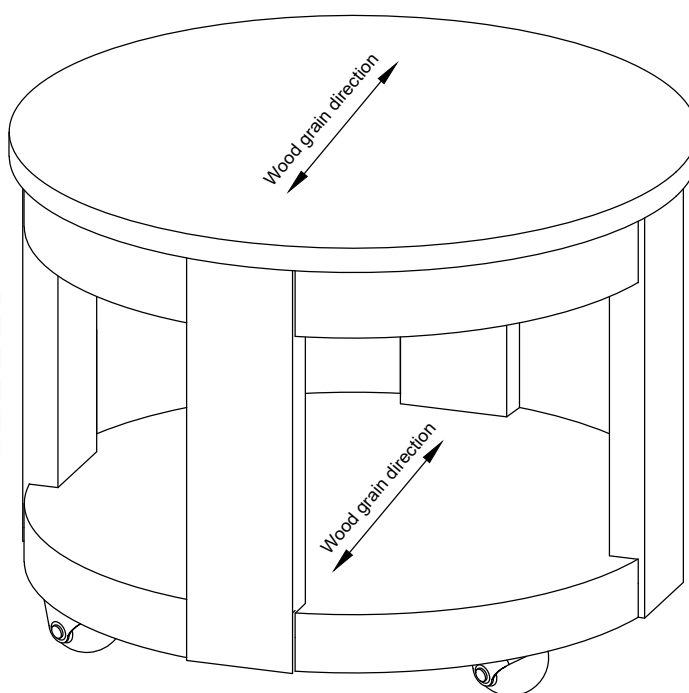

-Grains of the panel should  
be same direction  
-Les grains du panneau doivent  
être dans la même direction .

Assembly completed  
Made in VietNam