

ASSEMBLY INSTRUCTIONS /  
INSTRUCTIONS D'ASSEMBLAGE

---

ITEM NO/NO ARTICLE: IZAACCTB/161853CT

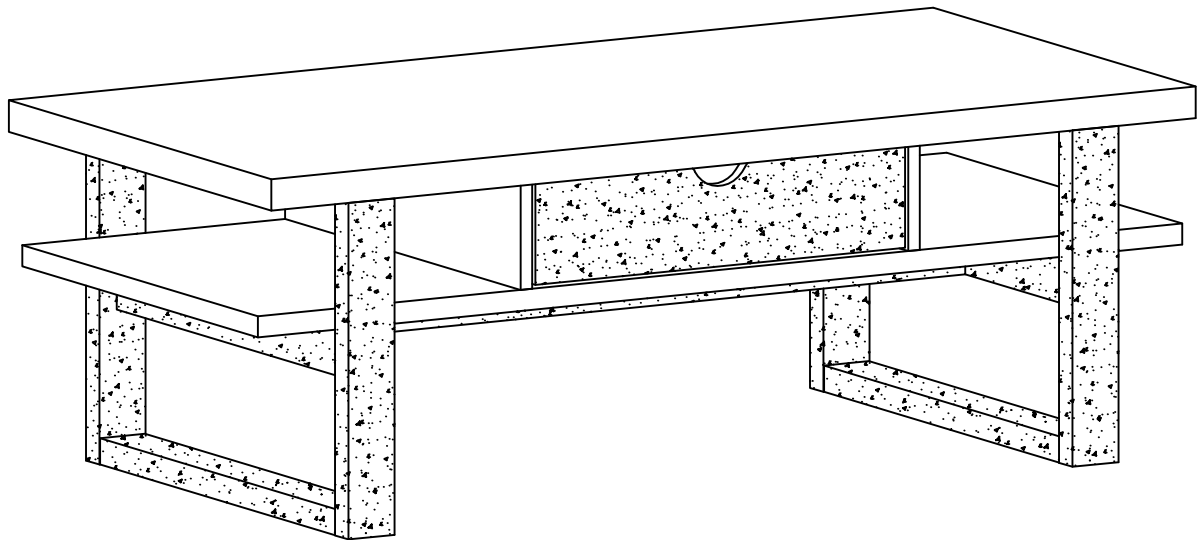

# PARTS IDENTIFICATIONS / IDENTIFICATION DES PIECES



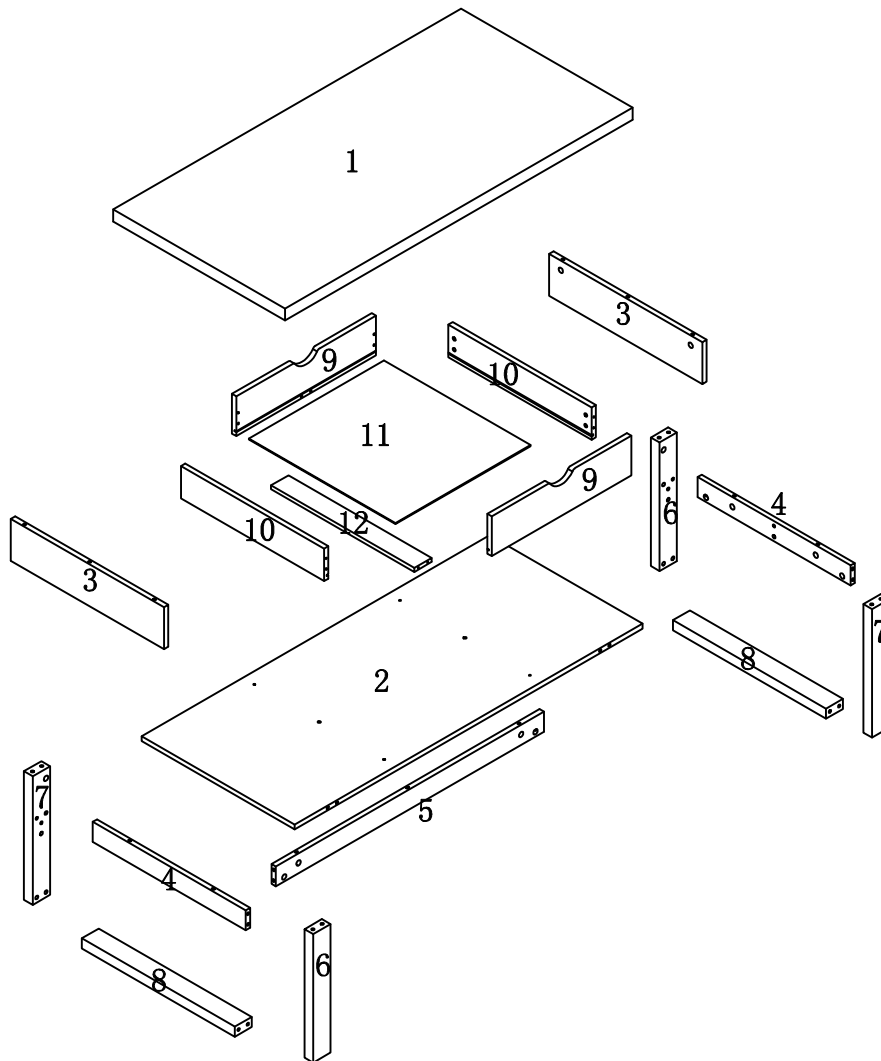



ITEM NO/NO ARTICLE: IZAACCTB/161853CT

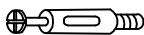

(1)	1pc/pce	(7)	2pcs/pces
(2)	1pc/pce	(8)	2pcs/pces
(3)	2pcs/pces	(9)	2pcs/pces
(4)	2pcs/pces	(10)	2pcs/pces
(5)	1pc/pce	(11)	1pc/pce
(6)	2pcs/pces	(12)	1pc/pce

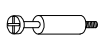
# HARDWARE IDENTIFICATIONS/ IDENTIFICATION DU KIT D'ASSEMBLAGE

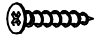
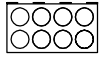
ITEM NO/NO ARTICLE: IZAACCTB/161853CT

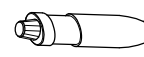
A		L29	32pcs/pces
B		Φ 15	32pcs/pces
C		Φ 8x25	19pcs/pces
D		L20	8pcs/pces
E		Φ 12	8pcs/pces
F		Φ 6x30	4pcs/pces
G		Φ 4x30	4pcs/pces
H		Φ 22 (WW)	4pcs/pces
I		Φ 16	4pcs/pces
J		<p>Glue: For securing please apply to wood dowel first before inserting into panel. Colle: Appliquez de la colle sur les goujons en bois avant de les insérer dans le panneau.</p>	1pc/pce

# ITEM NO/NO ARTICLE: IZAACCTB/161853CT

---

## STEP 1 / ETAPE 1

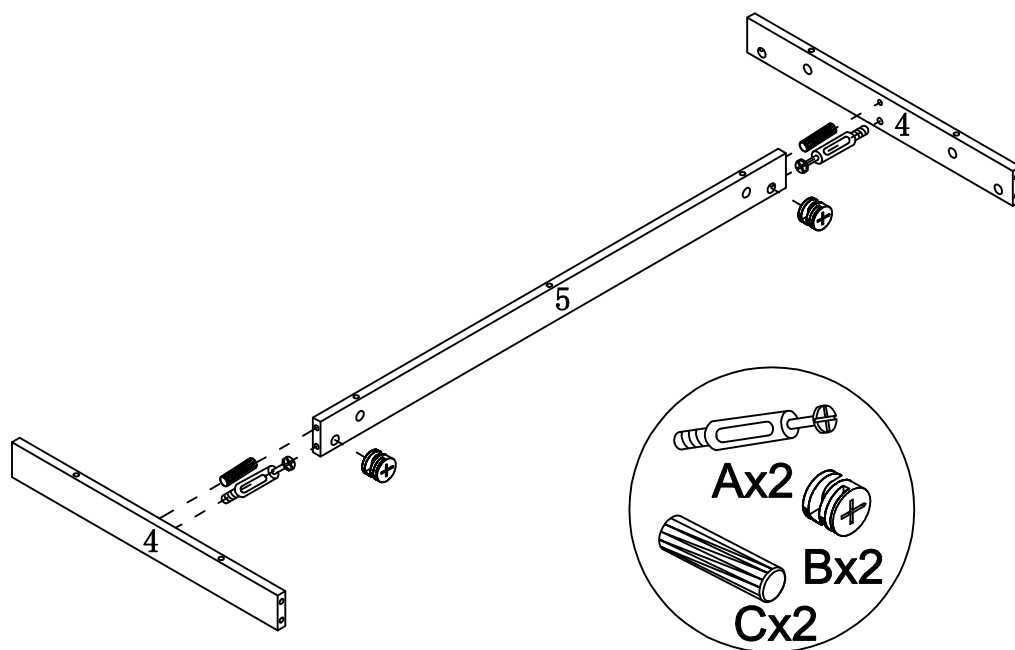

ITEM NO/NO ARTICLE: IZAACCTB/161853CT

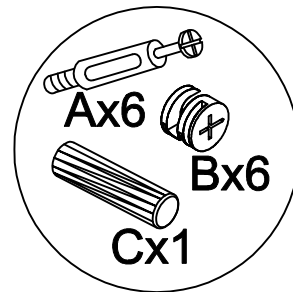
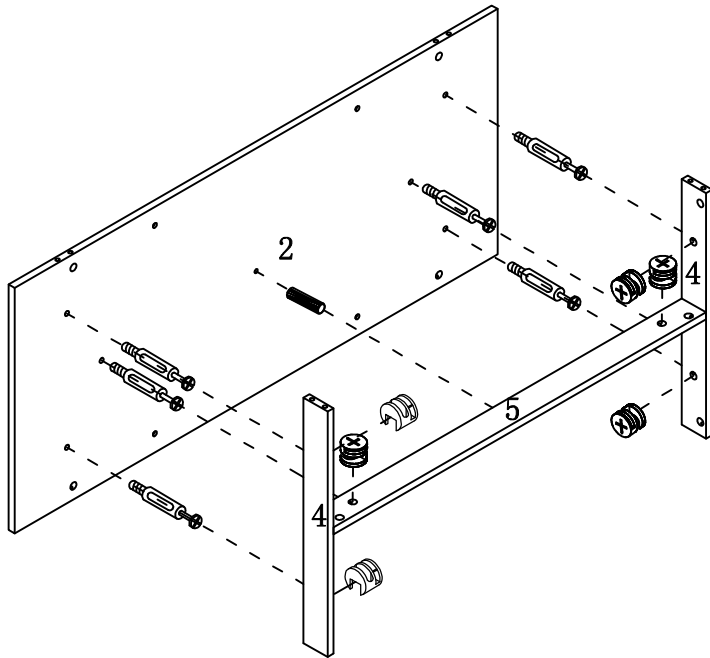

STEP 2 / ETAPE 2

STEP 3 / ETAPE 3

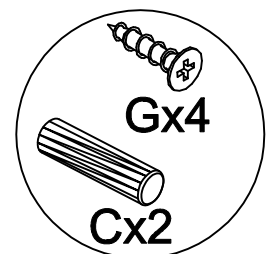
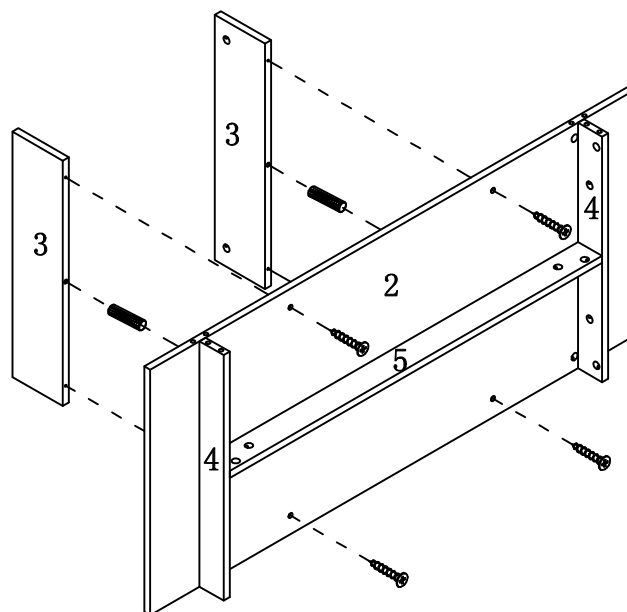

# ITEM NO/NO ARTICLE: IZAACCTB/161853CT

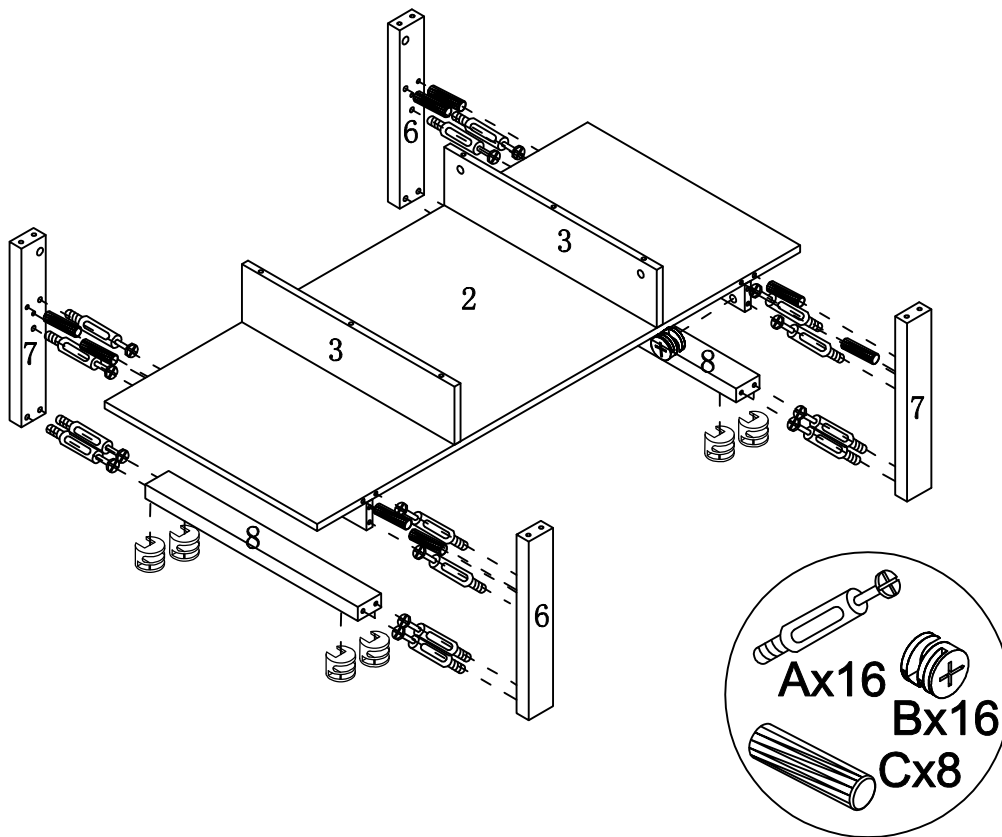

STEP 4 / ETAPE 4

STEP 5 / ETAPE 5

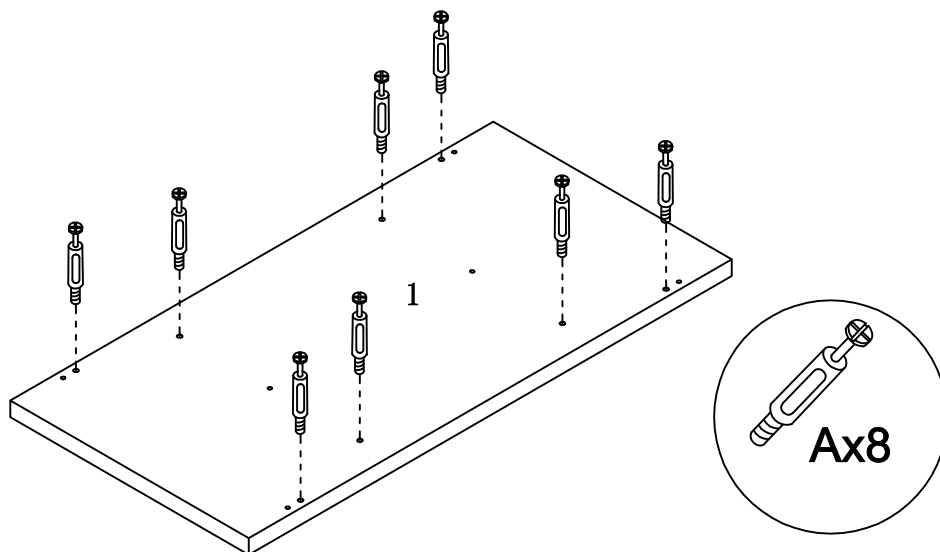

# ITEM NO/NO ARTICLE: IZAACCTB/161853CT

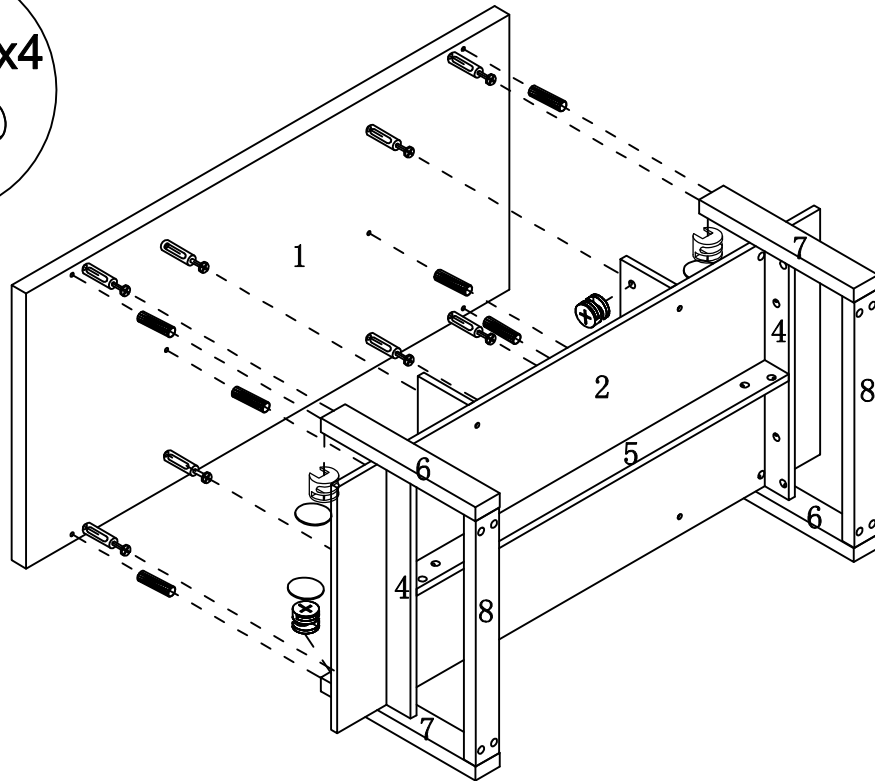
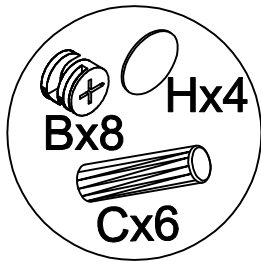

STEP 6 / ETAPE 6

STEP 7 / ETAPE 7

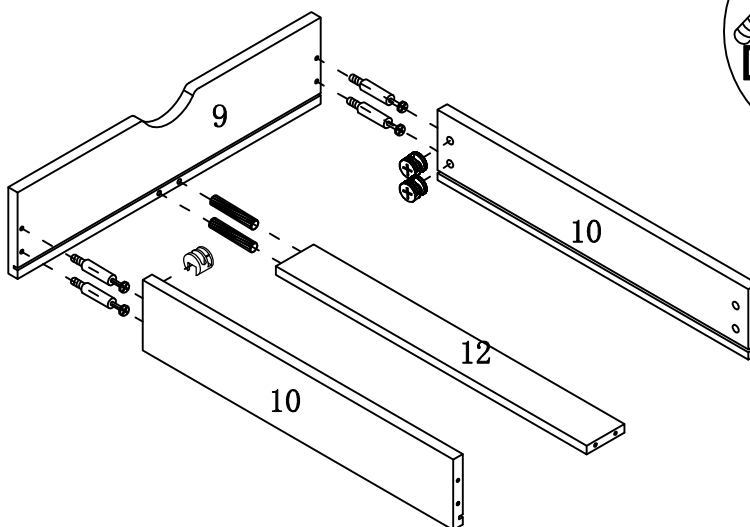
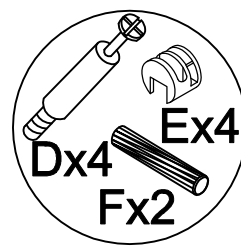

# ITEM NO/NO ARTICLE: IZAACCTB/161853CT

---

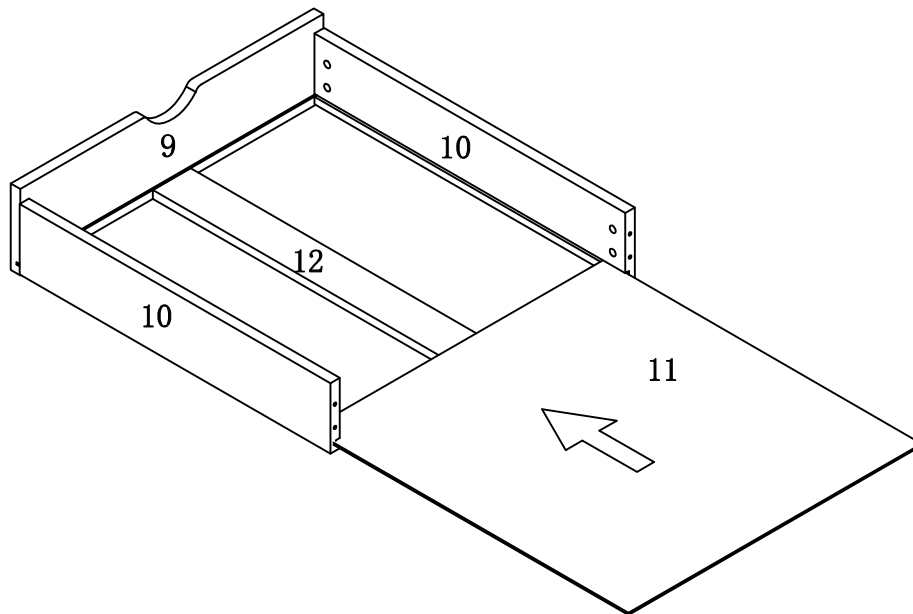

STEP 8 / ETAPE 8

STEP 9 / ETAPE 9

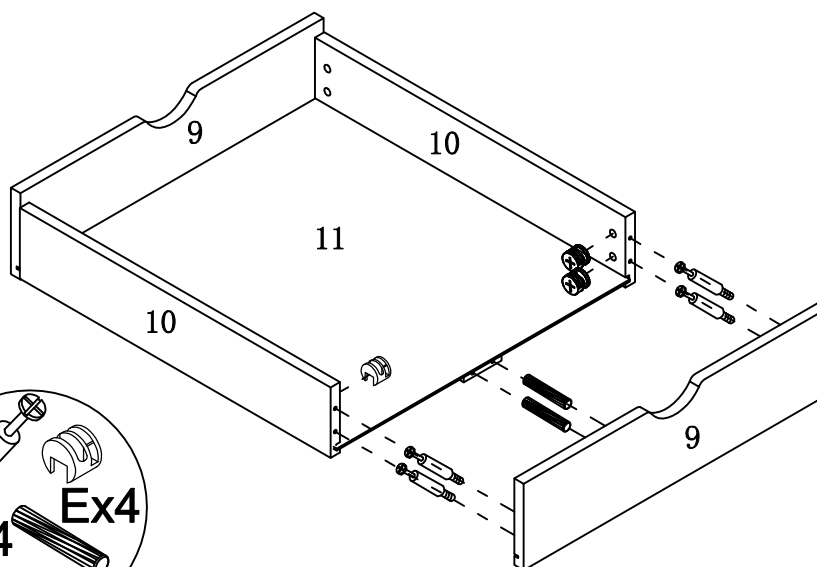



ITEM NO/NO ARTICLE: IZAACCTB/161853CT

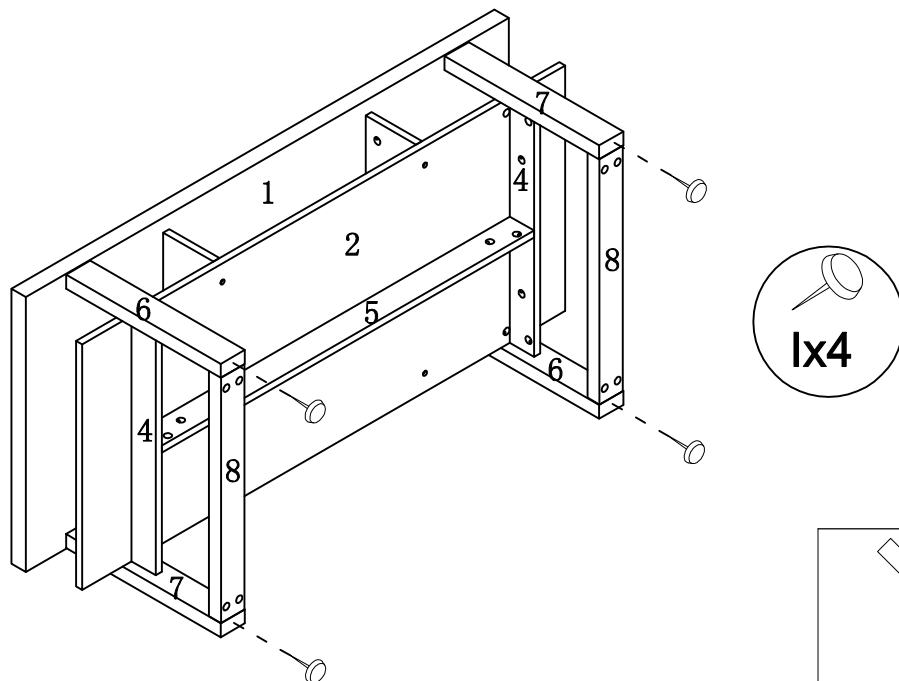

STEP 10 / ETAPE 10

STEP 11 / ETAPE 11

