

VENDOR: Xin Jian (014D) ELIJTCST/634-24 ELIJGCST/634-24GR
 ELIJACST/634-24LG ELIJCCST/634-24LBRO
 ELIJBCST/634-24BLK BAY0ACST/634-24LB
 BAY0YCST/634-24LY BAY0BCST/634-24LDG
 BAY0TCST/634-24LNG

ASSEMBLY INSTRUCTIONS (INSTRUCTIONS D'ASSEMBLAGE)

HARDWARE LIST (LISTE DES OUTILS):

NO.	SKETCH	DESCRIPTION	QTY
A		Bolt(1/4"*1-1/8") Boulon	4 PCS
B		Bolt(1/4"*7/8") Boulon	4 PCS
C		Bolt(1/4"*5/8") Boulon	8 PCS
D		Washer(1/4"*Ø16) Rondelle plate	12 PCS
E		Washer(1/4"*Ø13) Rondelle plate	4 PCS
F		Spring washer(1/4") Rondelle frein	16 PCS
G		Allen wrench(4mm) Clé hexagonale	1 PC

PARTS LIST (LISTE DES PIÉCES):

NO.	SKETCH	DESCRIPTION	QTY
1		Seat Siège	1 PC
2		Leg support Support de pied	1 PC
3		Leg Pied	4 PCS
4		Rotary turntable Table tournante rotative	1 PC

Step 1 / Étape 1

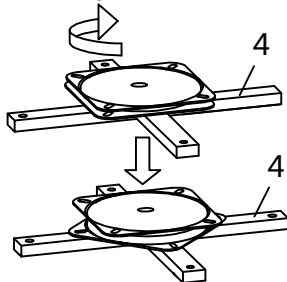

Note: Please press down and rotate Rotary Turntable (4) to the picture below.
 Appuyer sur le bouton et faire tourner la table tournante (4) comme indiqué sur l'image ci-dessous.

Step 2 / Étape 2

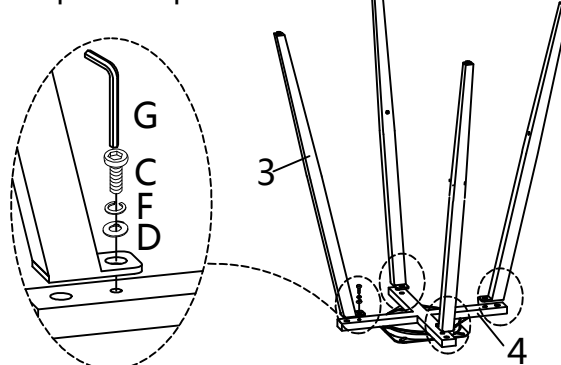

Note: At this stage, do not fully tighten the bolts.
 À noter qu'il ne faut pas serrer complètement les boulons à ce stade.

Step 3 / Étape 3

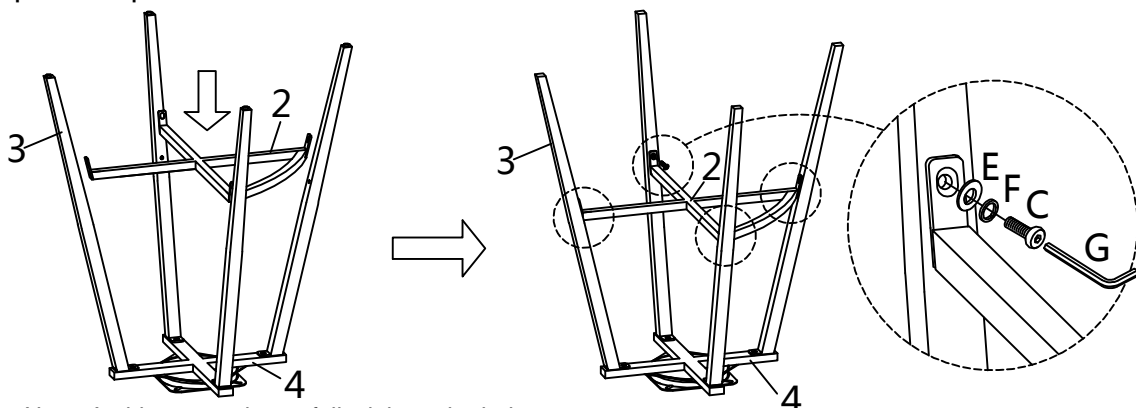

Note: At this stage, do not fully tighten the bolts.
 À noter qu'il ne faut pas serrer complètement les boulons à ce stade.

VENDOR: Xin Jian (014D) ELIJTCST/634-24 ELIJGCST/634-24GR
 ELIJACST/634-24LG ELIJCCST/634-24LBRO
 ELIJBCST/634-24BLK BAY0ACST/634-24LB
 BAY0YCST/634-24LY BAY0BCST/634-24LDG
 BAY0TCST/634-24LNG

ASSEMBLY INSTRUCTIONS (INSTRUCTIONS D'ASSEMBLAGE)

Step 4 / Étape 4

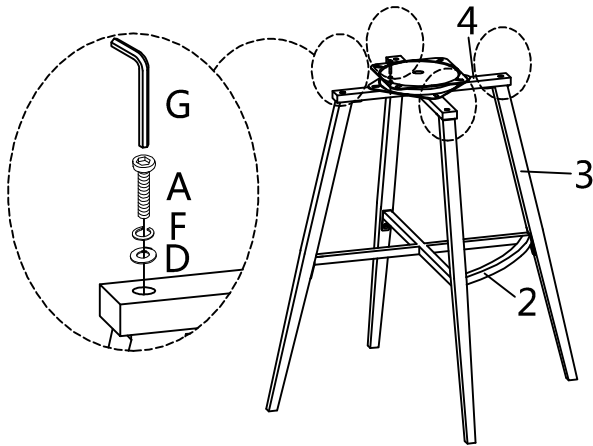

Step 5 / Étape 5

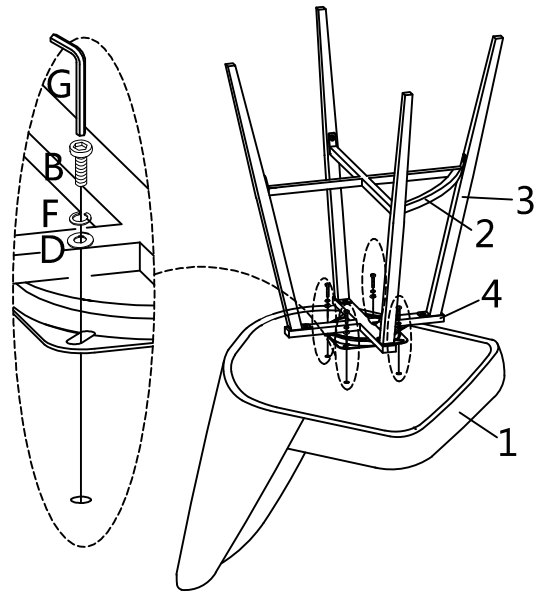

Step 6 / Étape 6

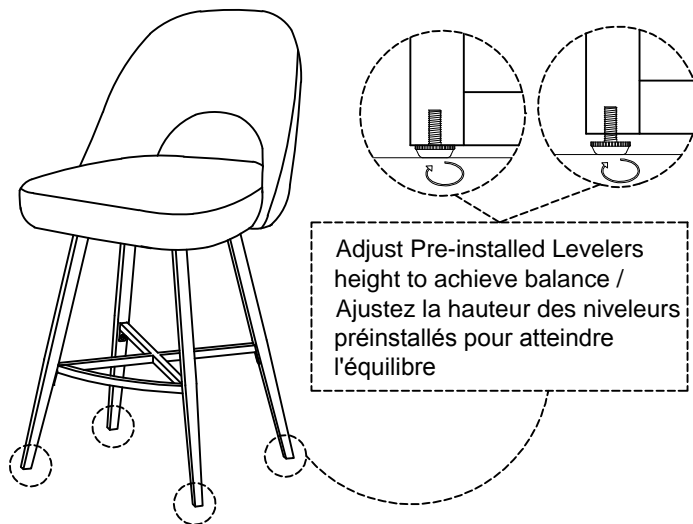

Step 7 / Étape 7

