

ASSEMBLY INSTRUCTIONS /
INSTRUCTIONS D'ASSEMBLAGE

ITEM NO/NO ARTICLE:EMR84TV/192541TV

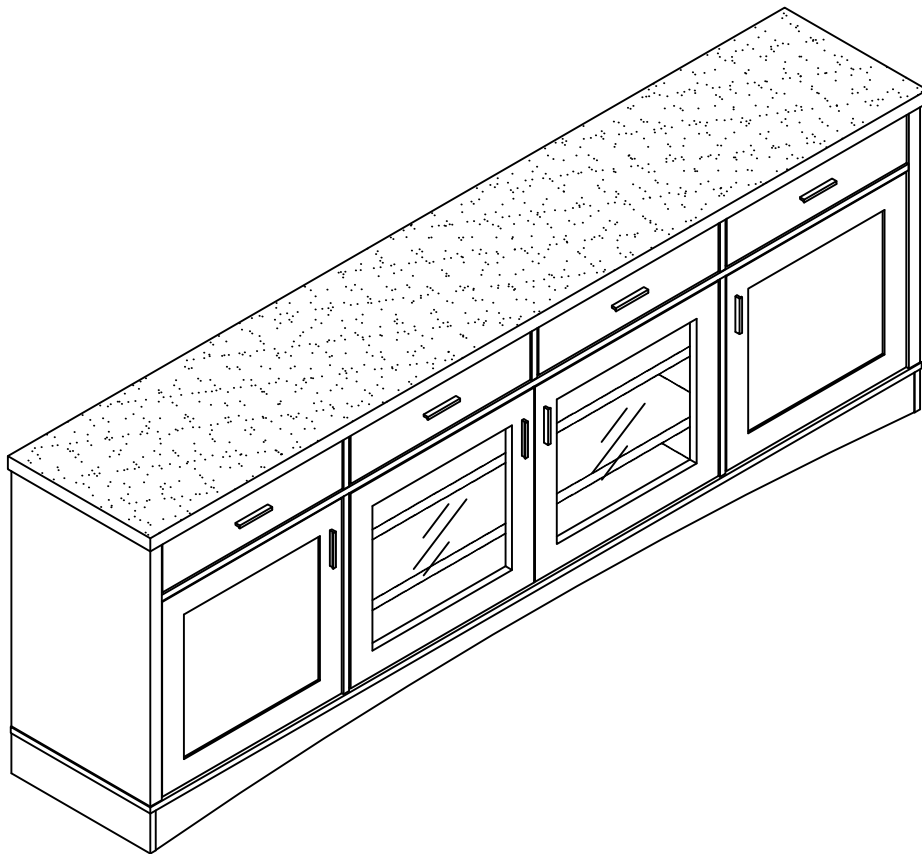

PARTS IDENTIFICATIONS / IDENTIFICATION DES PIECES



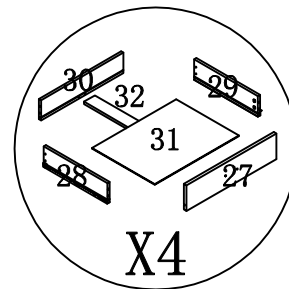
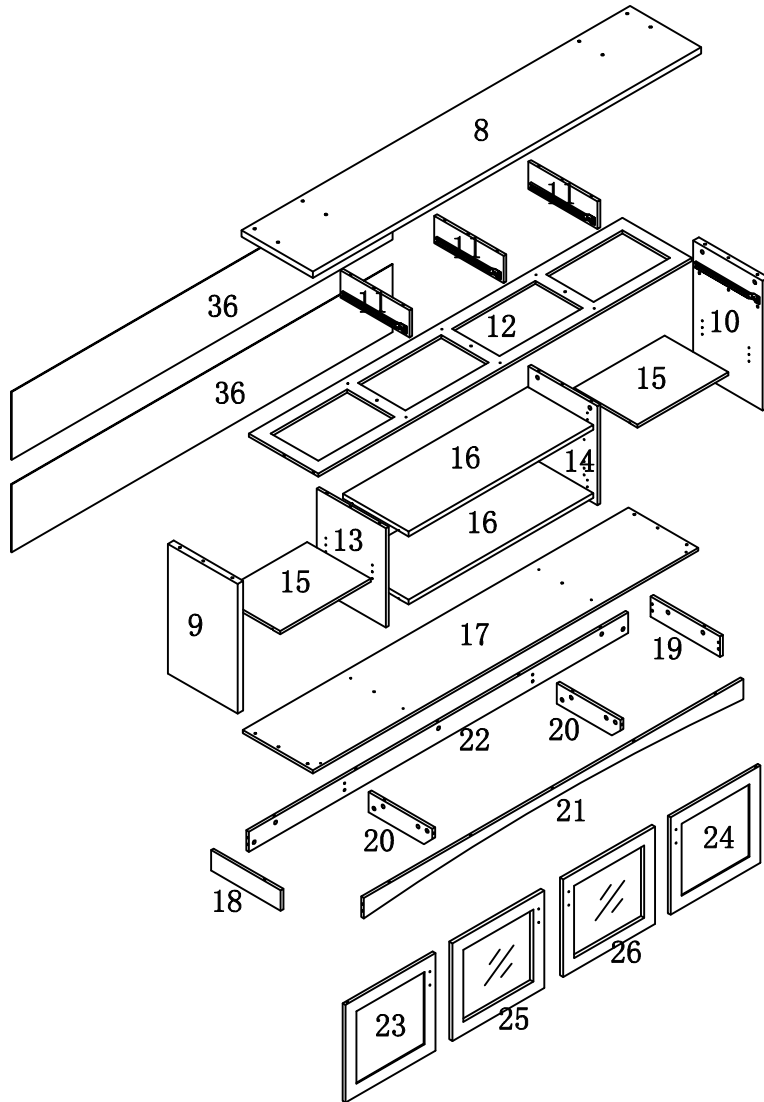











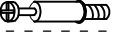















ITEM NO/NO ARTICLE:EMR84TV/192541TV



(8) 1pc/pce	(19) 1pc/pce	(30) 4pcs/pces
(9) 1pc/pce	(20) 2pcs/pces	(31) 4pcs/pces
(10) 1pc/pce	(21) 1pc/pce	(32) 4pcs/pces
(11) 3pcs/pces	(22) 1pc/pce	(36) 2pcs/pces
(12) 1pc/pce	(23) 1pc/pce	
(13) 1pc/pce	(24) 1pc/pce	
(14) 1pc/pce	(25) 1pc/pce	
(15) 2pcs/pces	(26) 1pc/pce	
(16) 2pcs/pces	(27) 4pcs/pces	
(17) 1pc/pce	(28) 4pcs/pces	
(18) 1pc/pce	(29) 4pcs/pces	

**HARDWARE IDENTIFICATIONS/
IDENTIFICATION DU KIT D'ASSEMBLAGE**

ITEM NO/NO ARTICLE:EMR84TV/192541TV

A		Φ 15	40pcs/pces
B		L29	40pcs/pces
C		Φ 8x25	24pcs/pces
D		Φ 12	16pcs/pces
E		L20	16pcs/pces
F		Φ 6x30	8pcs/pces
G		Φ 3x12	4pcs/pces
H		Φ 3x16	4pcs/pces
I		Φ 4x16	16pcs/pces
J		Φ 4x30	24pcs/pces
K		Φ 4x35	10pcs/pces
L		Φ 5x15	16pcs/pces
M			2pcs/pces
N			2pcs/pces
O			48pcs/pces
P		Φ 7x48	4pcs/pces
Q		Φ 8x Φ 16x2	4pcs/pces
R		Φ 16	9pcs/pces
S		64#	8pcs/pces
T		Φ 4x20	16pcs/pces
U			2pcs/pces
V		301C	4pcs/pces
W		Φ 22 WH3	15pcs/pces
X		197x5x1	1pcs/pce
Y		Φ 8x40	1pcs/pce
Z		12x12x1	2pcs/pces
Z1		Φ 5x40	1pcs/pce
Z2		Φ 4x25	1pcs/pce
Z3		<p>Glue: For securing please apply to wood dowel first before inserting into panel.</p> <p>Colle: Appliquez de la colle sur les goujons en bois avant de les insérer dans le panneau.</p>	1pc/pce
Z4		Φ 22 WNO	8pcs/pces

ASSEMBLY INSTRUCTIONS NOTICE D'ASSEMBLAGE

Necessary tools/Outils nécessaires



We recommend to apply some glue into holes before inserting wood dowels.
Nous vous recommandons d'appliquer quelques gouttes de colle dans les trous avant d'introduire les chevilles de bois.

How to use cam lock system/Comment utiliser le système de verrouillage

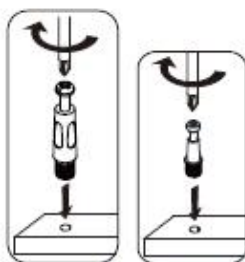

*Screw in cam post and tighten in place.
*Visser le montant de came et serrer en place.

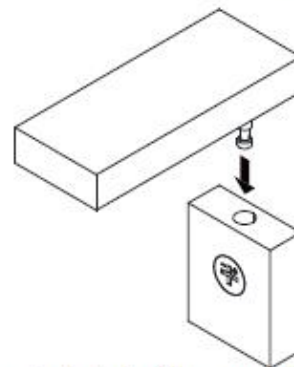
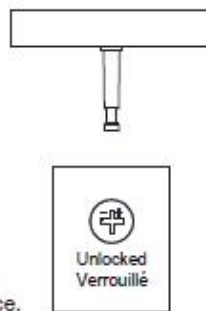

*Ensure that the cam lock arrow is pointed to the hole, align the cam lock screw to the hole of the cam lock case.
*Assurez-vous que la flèche de verrouillage sur l'écrou de sécurité est orientée vers l'orifice, insérez la vis de verrouillage dans l'orifice.

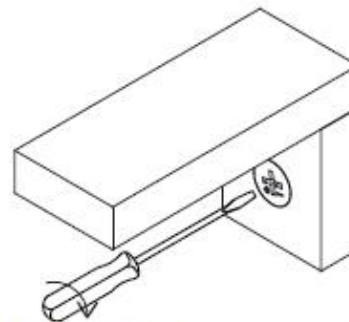
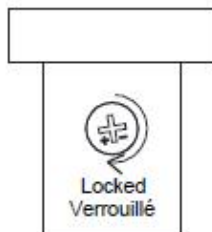

*Use a straight edge screwdriver to turn cam lock case until it is locked. Locked position is approximately 1/2 turn (210°) clockwise.

*Utilisez un tournevis ligne droite pour faire tourner l'écrou de sécurité afin de le verrouiller. La position verrouillée est environ 1/2 tour (210°) à la droite.

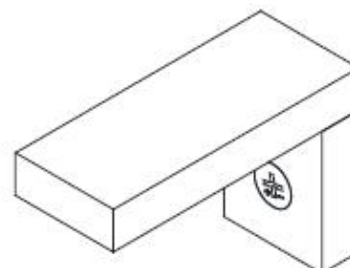
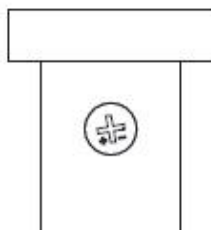

*After turning the cam lock case to the locked position, the cam lock arrow will be located in the position shown above.

*Après avoir tourné l'écrou de sécurité pour le verrouiller, la flèche de serrure de came se situeront dans la position indiquée ci-dessus.

ITEM NO/NO ARTICLE:EMR84TV/192541TV

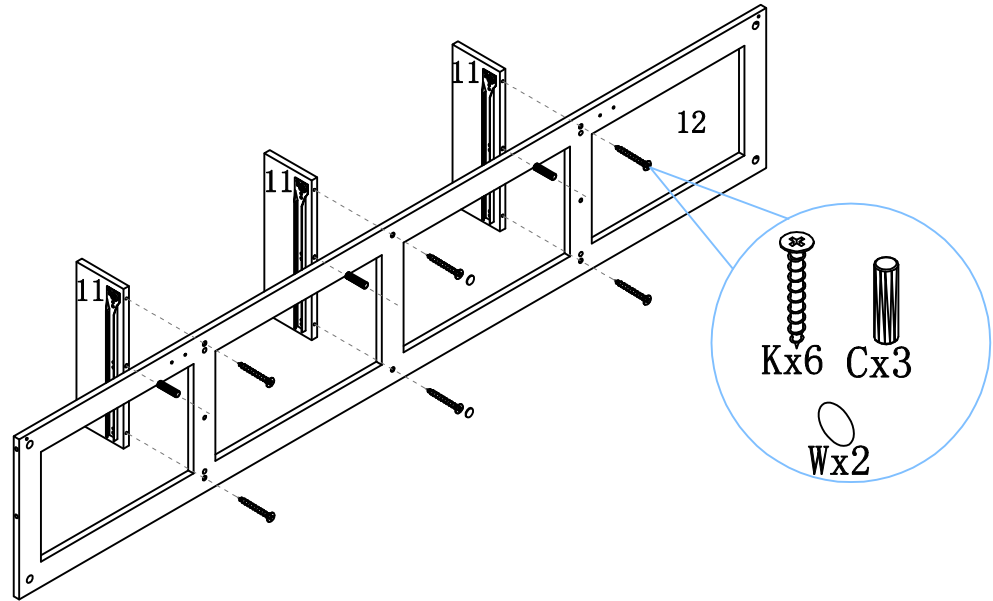

STEP 1 / ETAPE 1

STEP 2 / ETAPE 2

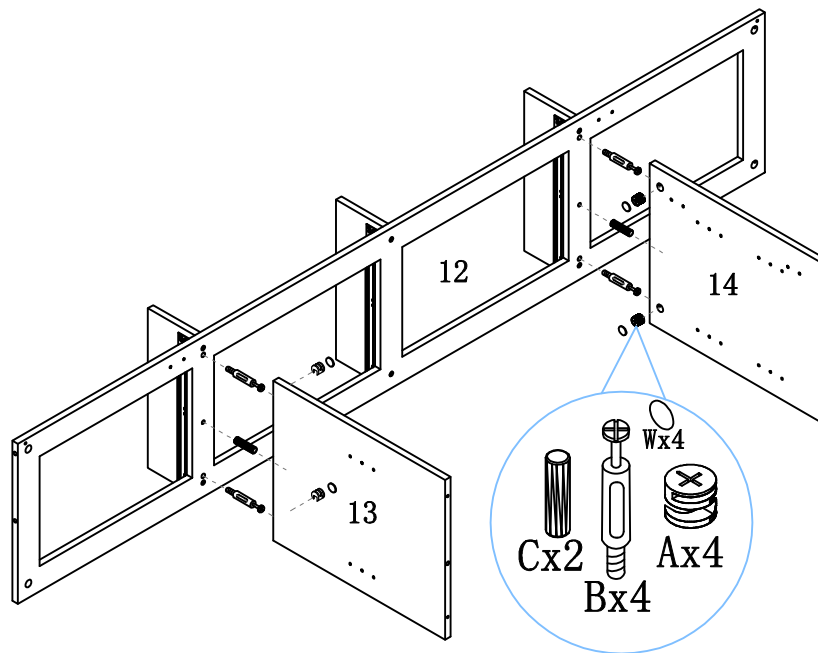

ITEM NO/NO ARTICLE:EMR84TV/192541TV

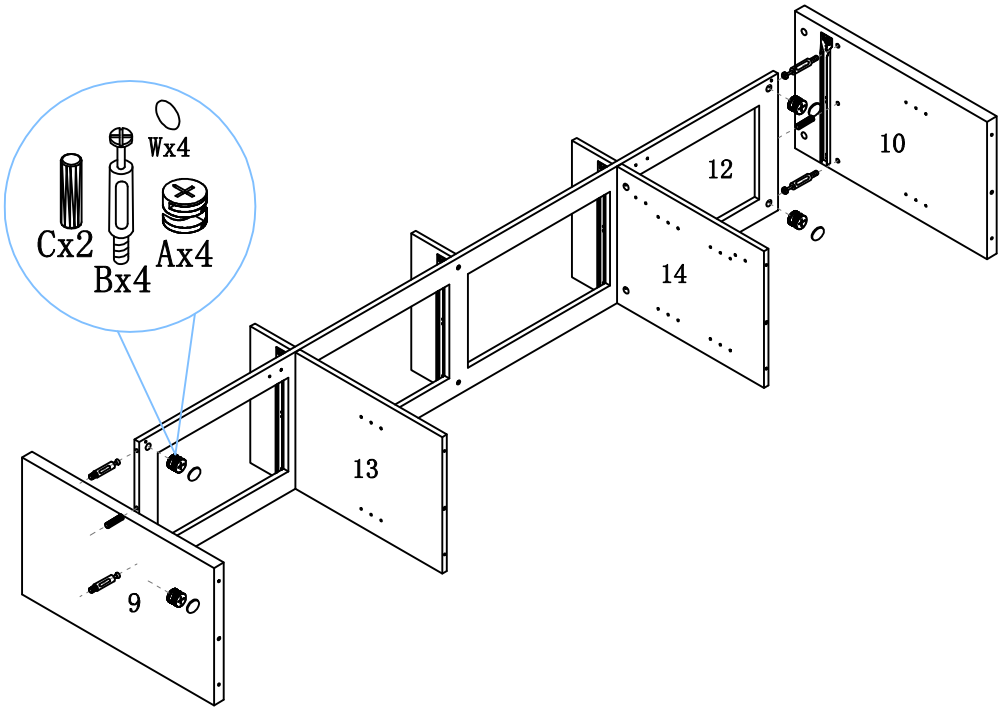

STEP 3 / ETAPE 3

STEP 4 / ETAPE 4

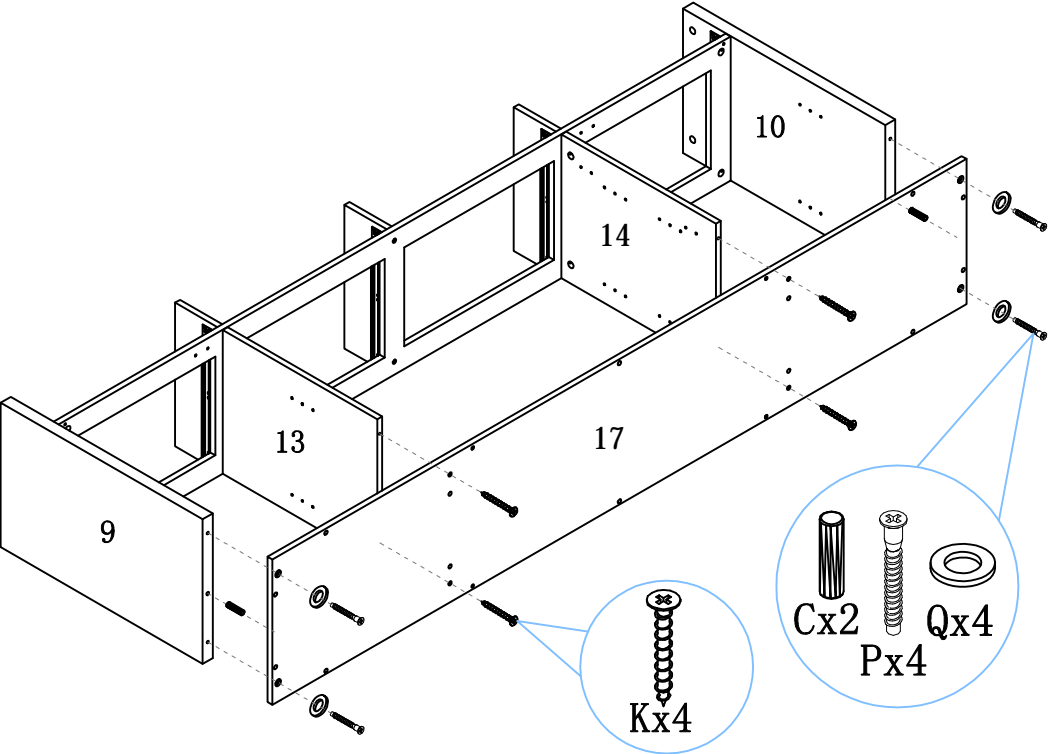

ITEM NO/NO ARTICLE:EMR84TV/192541TV

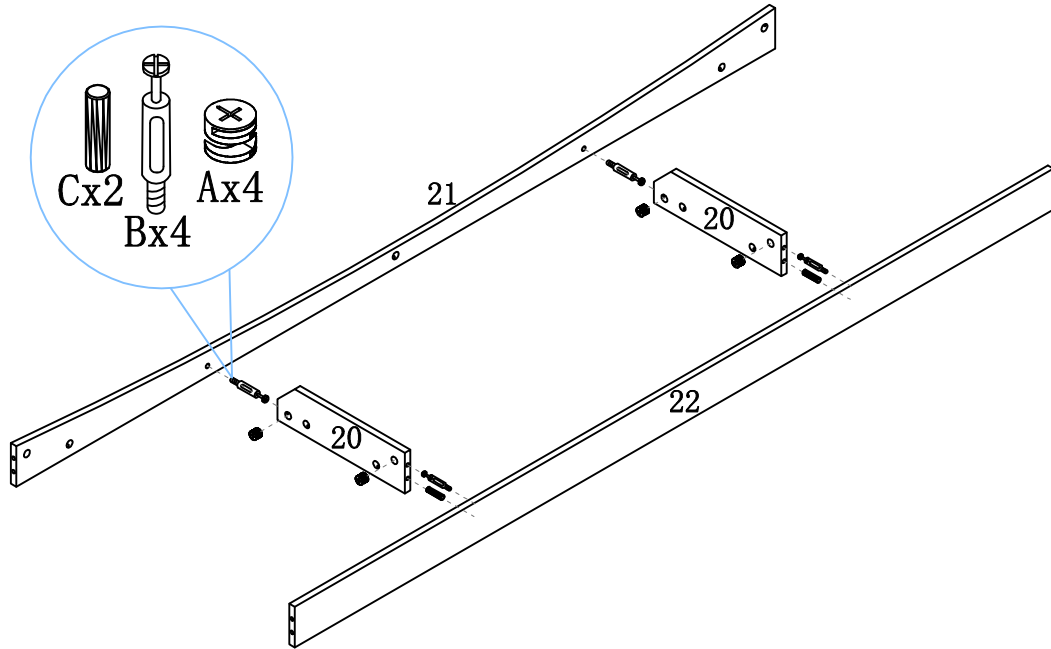

STEP 5 / ETAPE 5

STEP 6 / ETAPE 6

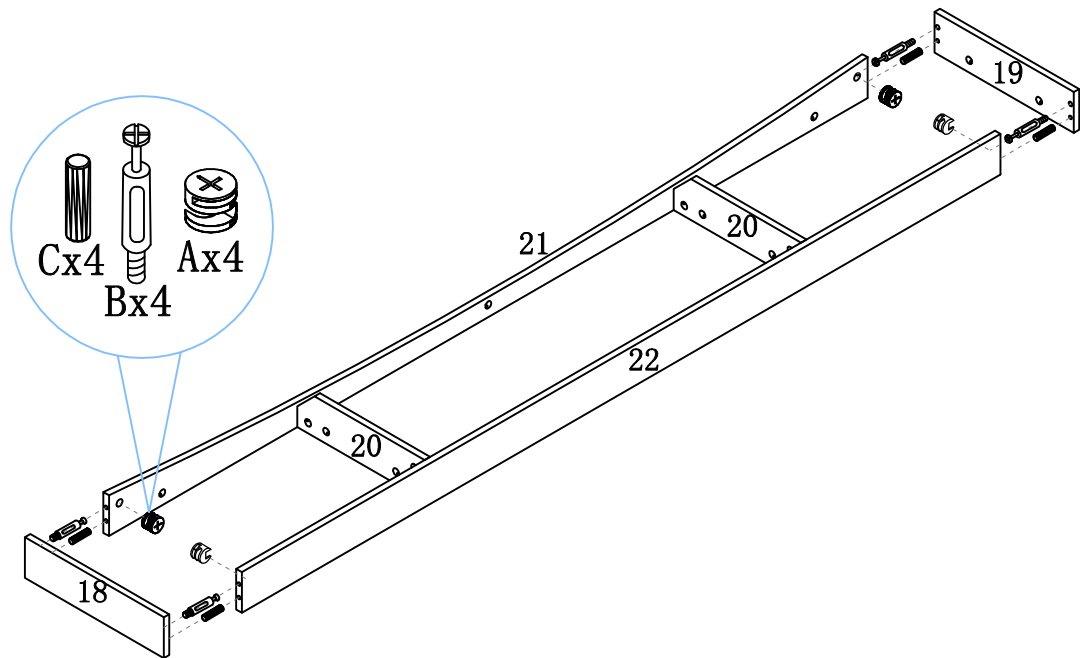

ITEM NO/NO ARTICLE:EMR84TV/192541TV

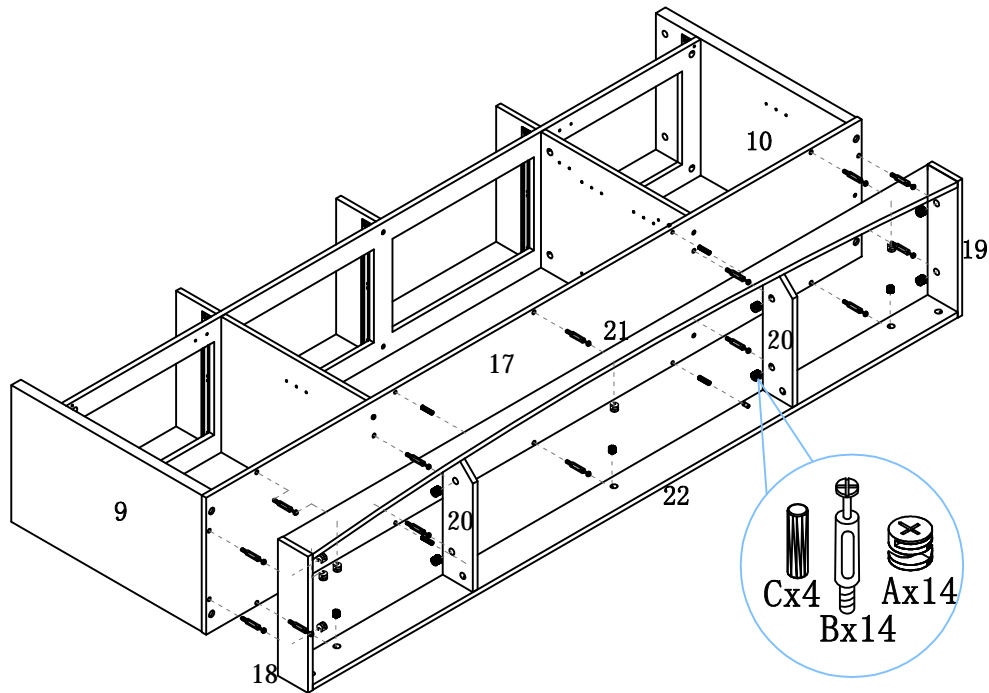

STEP 7 / ETAPE 7

STEP 8 / ETAPE 8

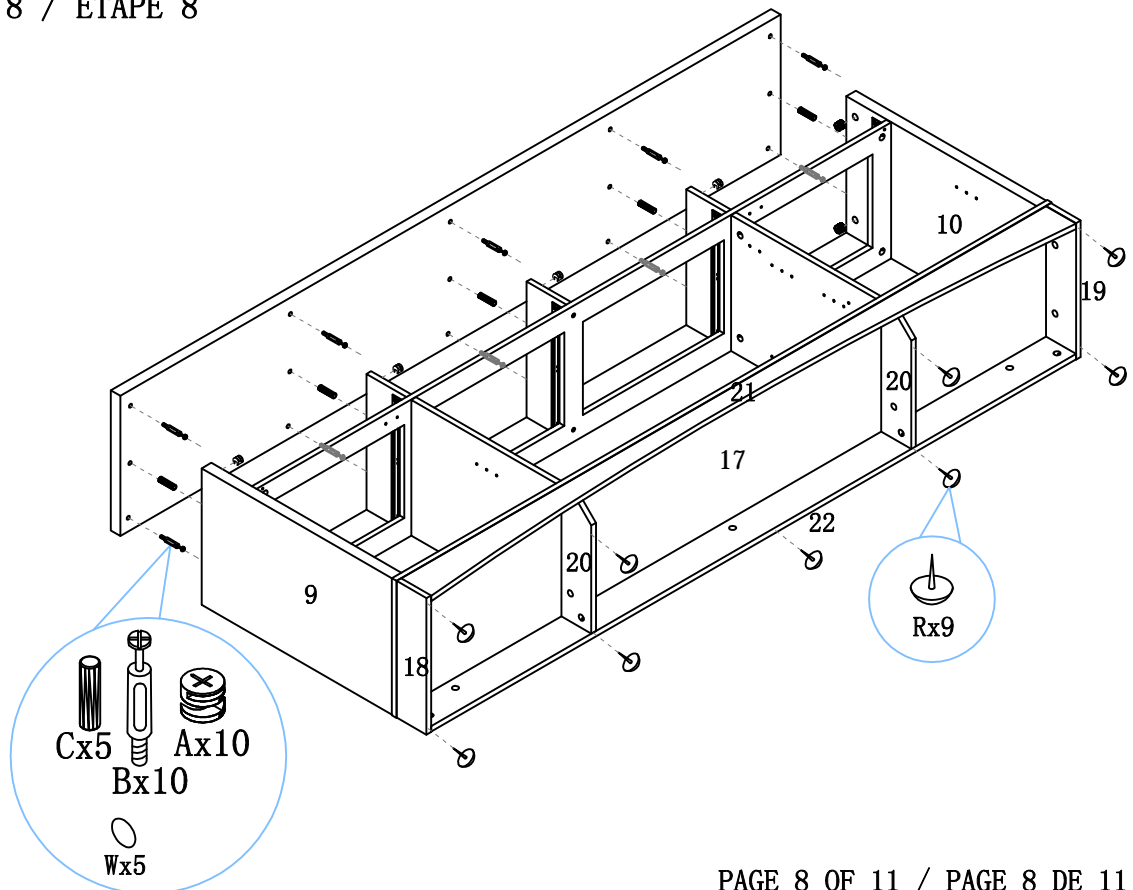

ITEM NO/NO ARTICLE:EMR84TV/192541TV

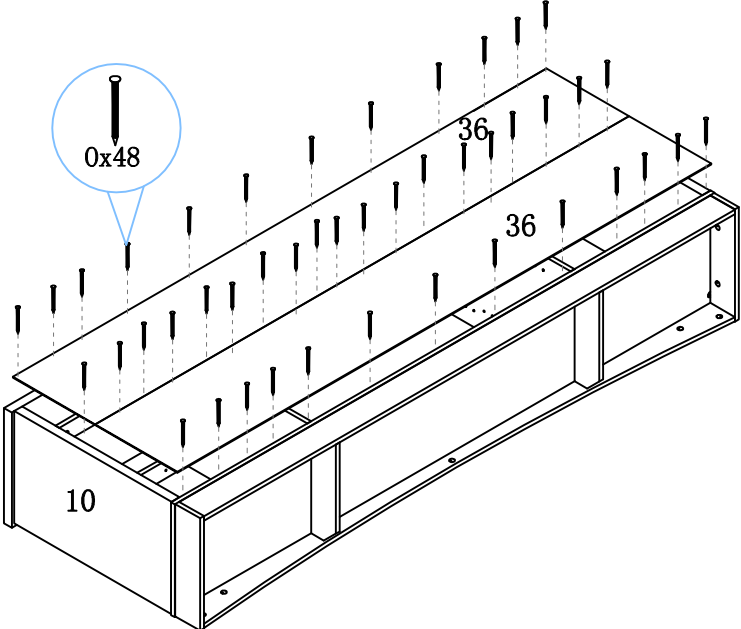

STEP 9 / ETAPE 9

STEP 10 / ETAPE 10

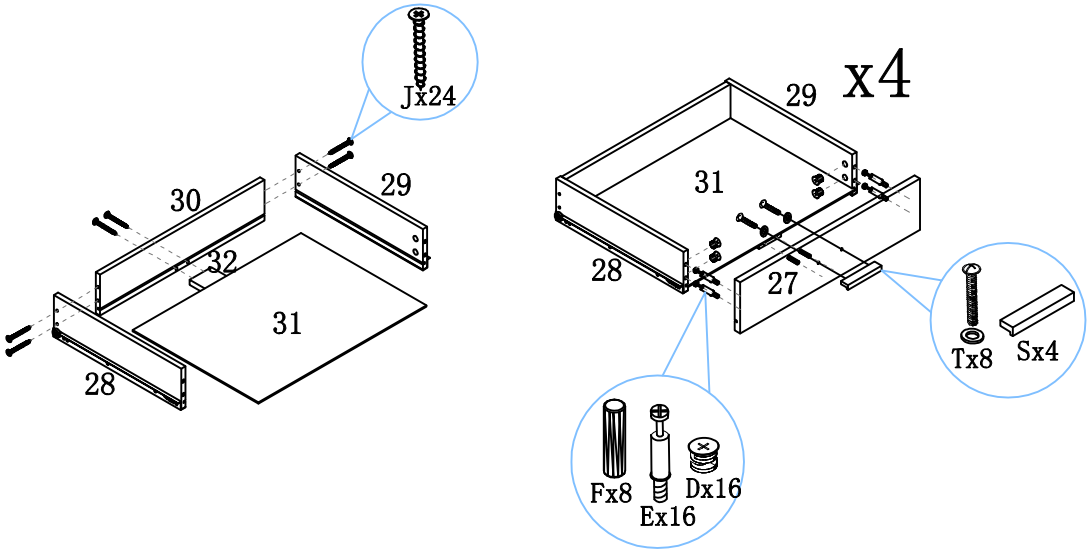

ITEM NO/NO ARTICLE:EMR84TV/192541TV

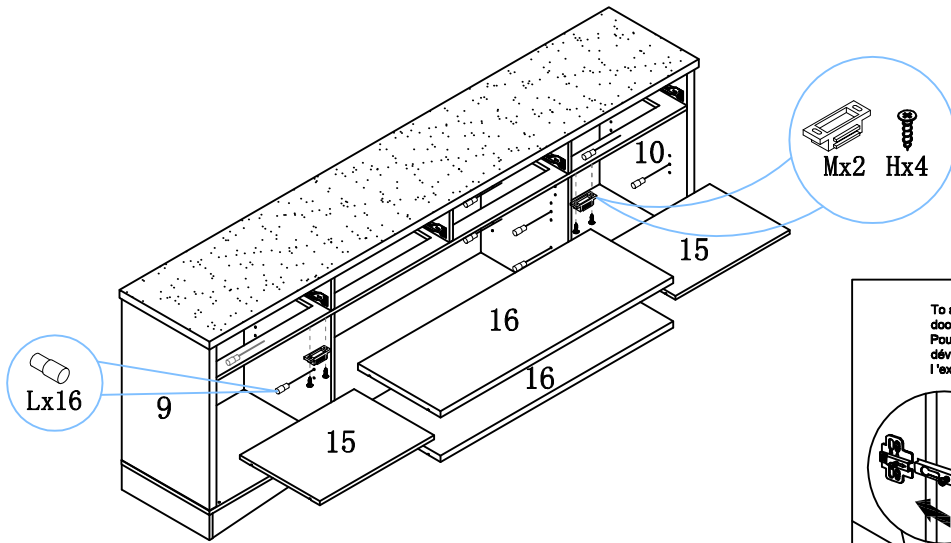

STEP 11 / ETAPE 11

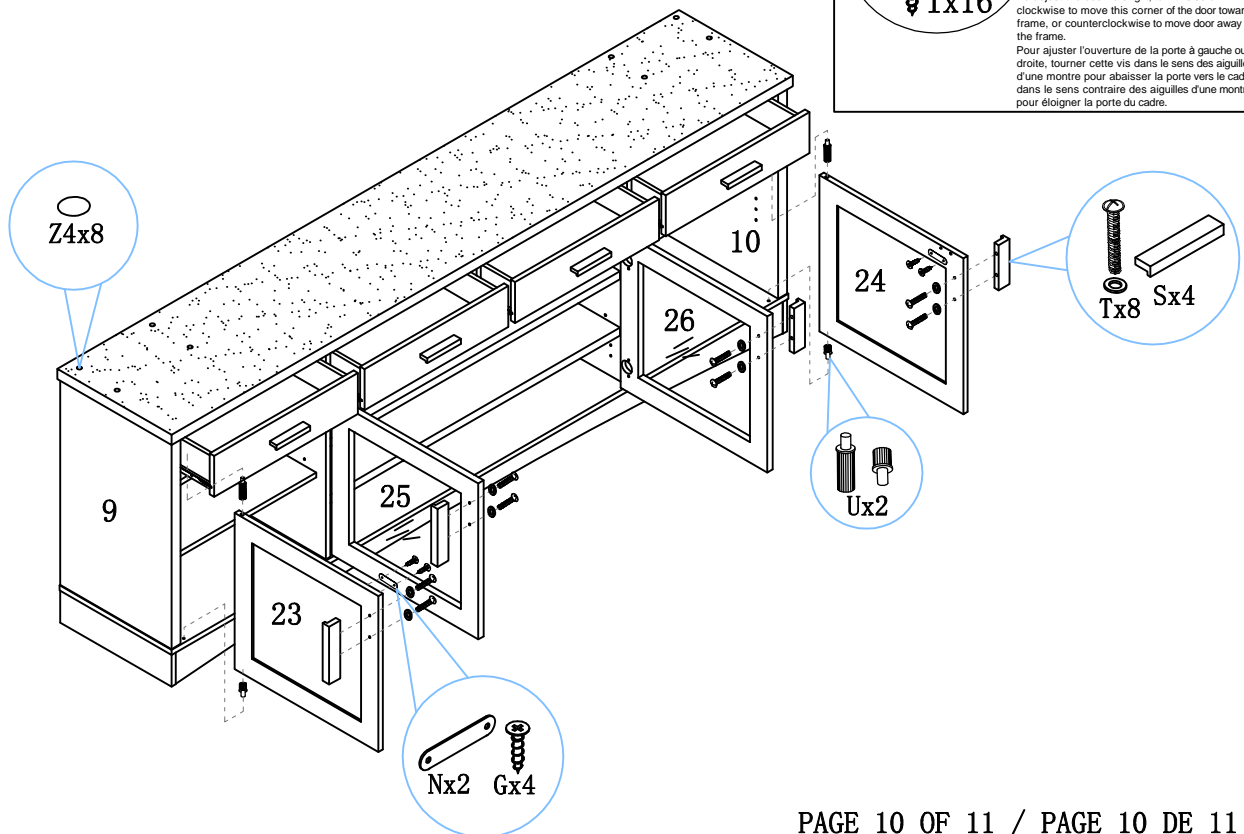
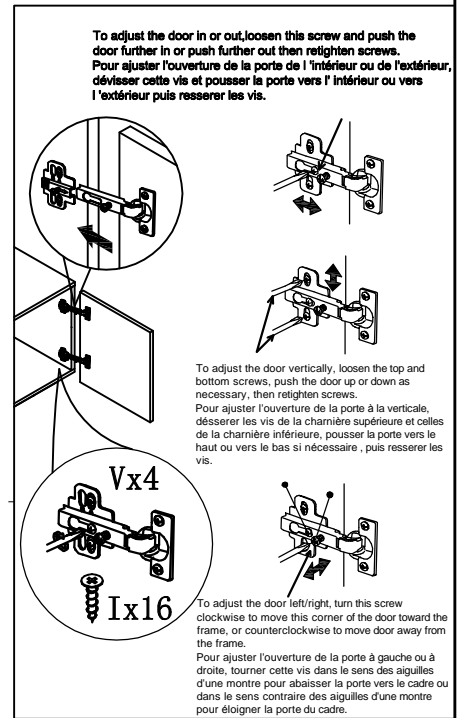

STEP 12 / ETAPE 12



ANTI-TIPPING STRAP INSTRUCTION

Instructions pour sangle anti-basculement

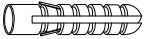
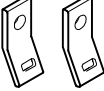
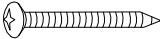
Quincaillerie (Incluse):

-  DRYWALL ANCHOR $\phi 8 \times 40$ X 1PCS
-  Fixation en métal $12 \times 12 \times 1$ X 2PCS
-  Vis $\phi 5 \times 40$ X 1PCS
-  Sangle $197 \times 5 \times 1$ X 1PCS
-  Vis $\phi 4 \times 25$ X 1PCS

Outils requis (Non inclus):

-  DRILL & DRILL BIT
Perceuse et trépan
-  LIGHT HAMMER
Marteau léger

Note: Hardware included only compatible with standard drywalls. :Notez que la quincaillerie incluse est compatible avec les ancrages de mur standard

Step 1 Étape 1

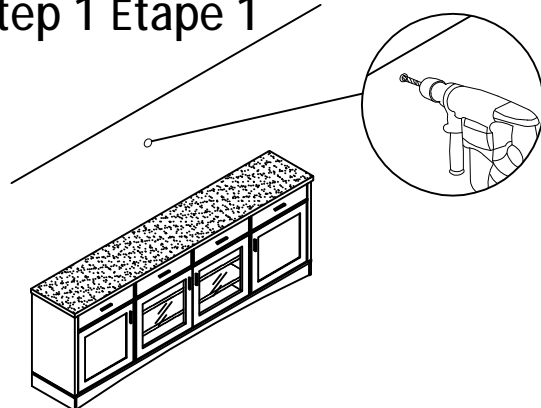

1. Find spot on wall 1" below the top of item.
Placer sur le mur à 1 pouce au-dessus de l'article.
2. Using a drill bit slightly smaller than the gauge of anchor, drill a hole, then place the anchor into wall.
À l'aide d'un trépan légèrement plus petit qu'un ancrage en acier de jauge, percer un trou puis placer l'ancrage dans le mur.

Step 2 Étape 2

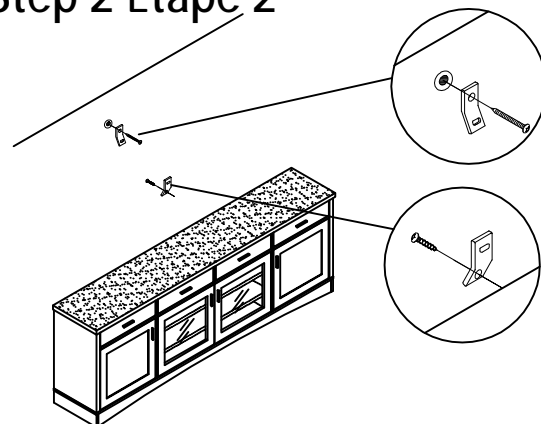

1. Screw the metal bracket into the anchor of wall.
Visser la première fixation en métal à l'intérieur de l'ancrage de mur.
2. Screw the second metal bracket into the back of item along the of soleid frame.
Visser la deuxième fixation à l'arrière de l'article.

Step 3 Étape 3

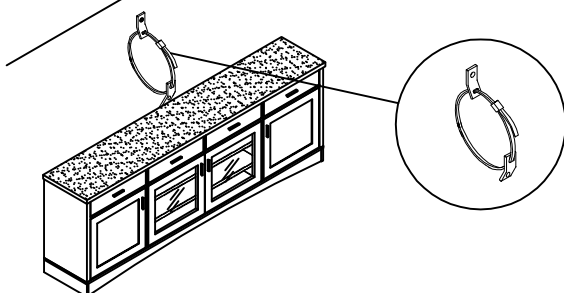

1. Insert strap thru the bracket attached to wall and the second attached to the product.
Insérer la sangle à l'intérieur de la fixation en métal. Elle s'attache facilement sur l'arrière du meuble, l'autre bout étant fixé au mur.
2. Pull tightly: Et puis tirer fermement.