

ASSEMBLY INSTRUCTIONS NOTICE D'ASSEMBLAGE

ITEM : Demi Cntrstool/Demi Barstool

Important note/Note importante:

1. Kindly follow the assembly instructions step by step./ Veuillez suivre la notice d'assemblage, pas à pas.
2. Do not tighten all screws and bolts until the chair is fully assembled./ Ne serrer les vis et boulons à fond que lorsque le produit est entièrement assemblé.

PARTS IDENTIFICATION / IDENTIFICATION DES PIÈCES

1 seat/siège

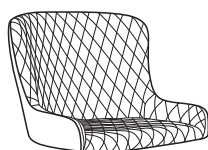

1pc

2 leg/pied

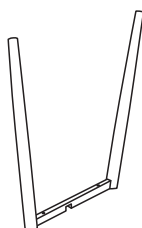

1pc

3 leg/pied

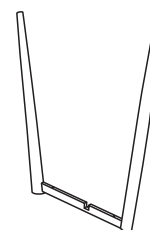

1pc

4 footrest/repose-pied

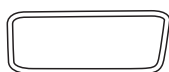

1pc

HARDWARE IDENTIFICATION / IDENTIFICATION DES PIÈCES MONTAGE

A Screw/Vis
M6x25mm



4pcs

B Screw/Vis
M6x50mm



4pcs

C Screw gasket/Vis
de serrage du joint
M6x16x1.5mm



4pcs

D Allen Key
Clé Allen
M4



1pc

ASSEMBLY INSTRUCTIONS NOTICE D'ASSEMBLAGE

ITEM : Demi Cntrstool/Demi Barstool

STEP 1 / ÉTAPE 1

STEP 1 : 50% tighten screw at this stage.
ÉTAPE 1 : À ce stade, serrer la vis à 50%.

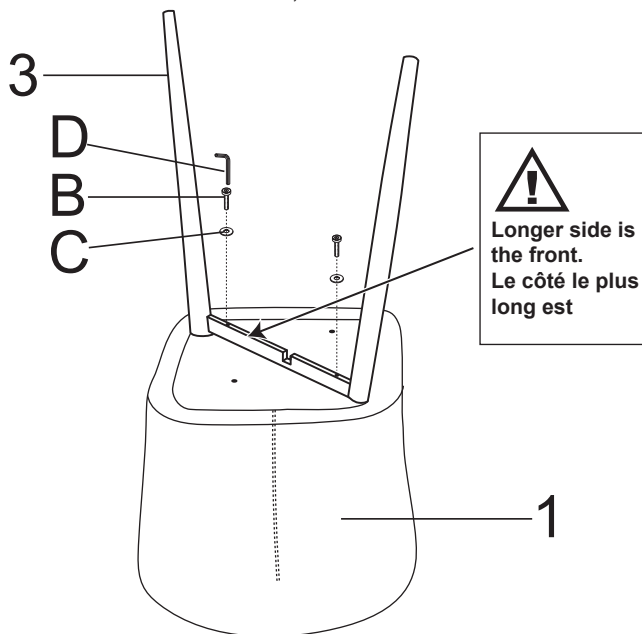

STEP 2 / ÉTAPE 2

STEP 2 : 50% tighten screw at this stage.
ÉTAPE 2 : À ce stade, serrer la vis à 50%.

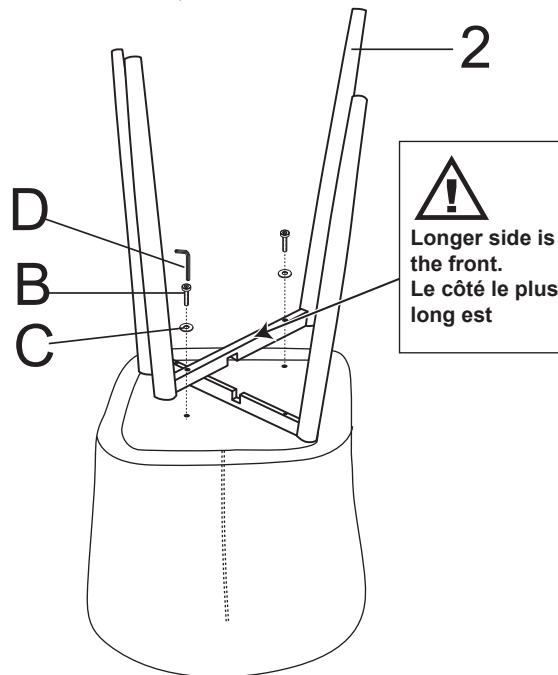

STEP 3 / ÉTAPE 3

STEP 3 : After all parts are in right position, then 100% tighten up all screws before using.
ÉTAPE 3 : Avant l'utilisation, une fois toutes les pièces à la bonne place, serrez toutes les vis à 100%.

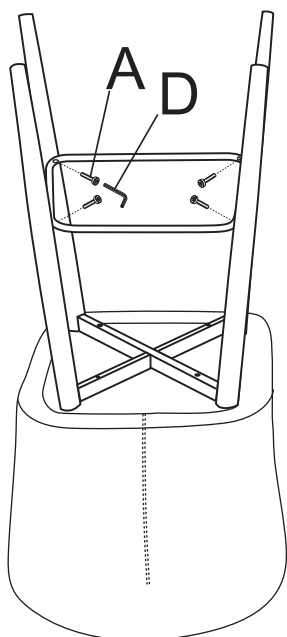

COMPLETE / ASSEMBLAGE TERMINÉ

