

ASSEMBLY INSTRUCTIONS / NOTICE D'ASSEMBLAGE

ITEM: JYP-1862 BDC AQUA&JYP-1862 BDC-BEIGE&JYP-1862 BDC-BROWN&JYP-1891 BCG-GREY/CHE3ADSC&CHE3TDSC&CHE3CDSC&CHELGDSC

Important note/ Note importante:

1. Place all wooden parts on a clean and smooth surface such as a rug or carpet to avoid scratching the parts. / Placer les pièces sur une surface propre et lisse tel qu'une couverture ou un tapis pour éviter d'endommager les pièces.
2. Kindly follow the assembly instructions step by step./ Veuillez suivre la notice d'assemblage, pas à pas.
3. Do not tighten all screws and bolts until the table is fully assembled./ Ne serrer les vis et boulons à fond que lorsque le produit est entièrement assemblé.
4. Unscrew the protective plastic supports from the metal insert of the table legs before assembly./ Dévisser les caches plastiques des embouts métalliques des pieds de la table avant l'assemblage.

PARTS IDENTIFICATION / IDENTIFICATION DES PIÈCES

A Chair Back
Dossier

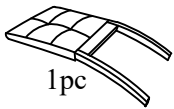

1pc

B Seat cushion
Coussin assise



1pc

C Front Leg
Pied Avant



2pcs

HARDWARE IDENTIFICATION / IDENTIFICATION DES PIÈCES MONTAGE

1 Bolt
Boulon

1/4"X40mm



2pcs

2 Long Bolt
Boulon long

1/4"X80mm



4pcs

3 Nut
Écrou

Ø5/16"



4pcs

4 Spring Washer
Rondelle D'arret

5/16"X11mm



10 pcs

5 Flat Washer
Rondelle Plate

5/16"X19mm



10 pcs

6 Allen Key
Clé Allen



1pc

7 Wrench
Clé

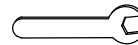

1pc

STEP 1 / ÉTAPE 1

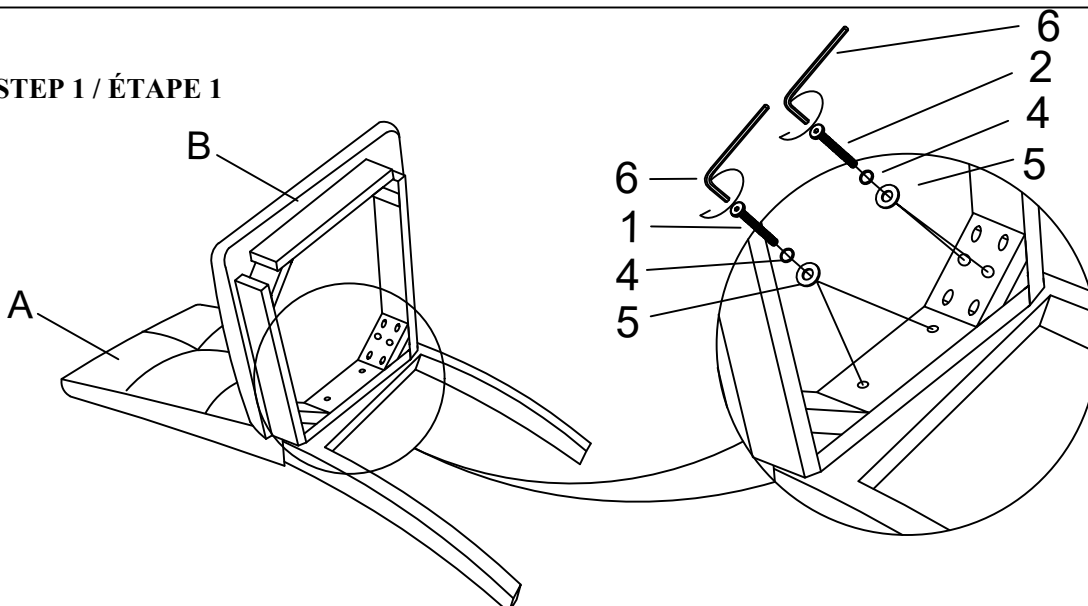

ASSEMBLY INSTRUCTIONS / NOTICE D'ASSEMBLAGE

ITEM: JYP-1862 BDC AQUA&JYP-1862 BDC-BEIGE&JYP-1862 BDC-BROWN&
JYP-1891 BCG-GREY/CHE3ADSC&CHE3TDSC&CHE3CDSC&CHELGDSC

STEP 2 / ÉTAPE 2

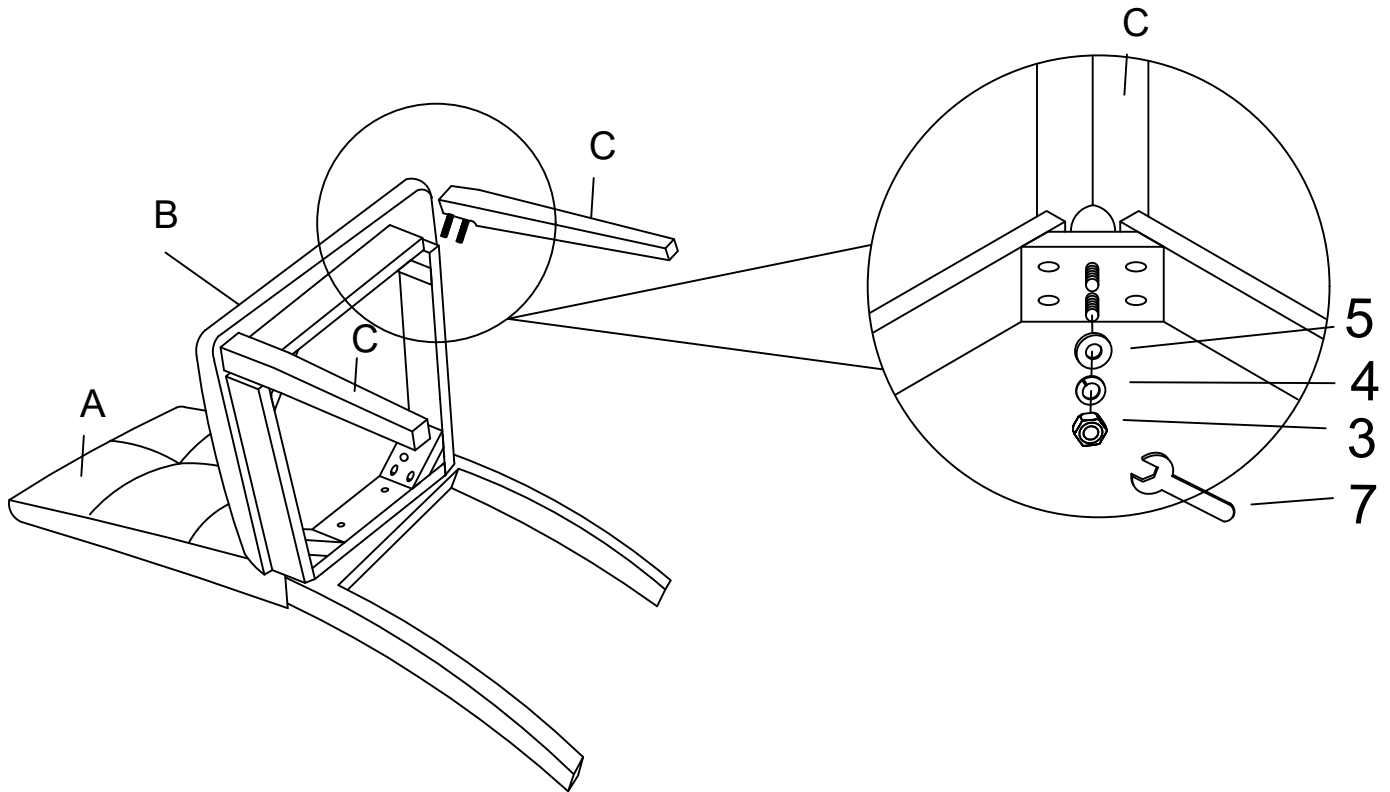

COMPLETE

