

**ASSEMBLY INSTRUCTION
INSTRUCTIONS D'ASSEMBLAGE**



ASSEMBLY TIPS:/TRUCS POUR L'ASSEMBLAGE :

- 1.REMOVE HARDWARE FROM BOX AND SORT BY SIZE.
1. RETIRER LA QUINCAILLERIE DE LA BOÎTE ET LA CLASSER PAR TAILLE.
- 2.PLEASE CHECK TO SEE THAT ALL HARDWARE AND PARTS ARE PRESENT PRIOR TO START OF ASSEMBLY
2. VÉRIFIER SI TOUTES LES PIÈCES ET LA QUINCAILLERIE SONT PRÉSENTES AVANT DE COMMENCER L'ASSEMBLAGE.
- 3.PLEASE FOLLOW ATTACHED INSTRUCTIONS IN THE SAME SEQUENCE AS NUMBERED TO ASSURE FAST &EASY ASSEMBLY.
3. SUIVRE LES INSTRUCTIONS CI-JOINTES SELON L'ORDRE INDIQUÉ POUR UN ASSEMBLAGE RAPIDE ET RÉUSSI.

WARNING/ATTENTION

- 1.DON'T ATTEMPT TO REPAIR OR MODIFY PARTS THAT ARE BROKEN OR DEFECTIVE.PLEASE CONTACT THE STORE IMMEDIATELY.
1. NE PAS TENTER DE RÉPARER NI DE MODIFIER LES PIÈCES BRISÉES OU DÉFECTUEUSES. S'ADRESSER SANS TARDER AU MAGASIN.
- 2.THIS PRODUCT IS FOR HOME USE ONLY AND NOT INTENDED FOR COMMERCIAL ESTABLISHMENT
2. CE PRODUIT EST DESTINÉ À UN USAGE À DOMICILE SEULEMENT ET NON À UN USAGE DANS LES ÉTABLISSEMENTS COMMERCIAUX.

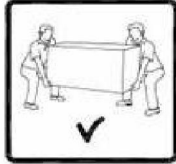





ASSEMBLY TIME PER UNIT:	15 MINUTES
-------------------------	------------

TEMPS D'ASSEMBLAGE PAR UNITÉ : 15 MINUTES

**PARTS IDENTIFICATION/
IDENTIFICATION DES PIÈCES :**

**HARDWARE IDENTIFICATION/
IDENTIFICATION DU MATÉRIEL D'ASSEMBLAGE**

(A)	BACK & SEAT/ DOSSIER ET SIÈGE			NO	DESCRIPTION	FIGURE	QTY/QTÈ
(B)	SEAT BASE/ BASE DU SIÈGE			1	BOLT/BOULON (M6*16)		4 PC 4 PCE
				2	ALLEN KEY/ CLÉ ALLEN 4MM		1PC 1 PCE
				3	ALLEN WRENCH /CLÉ ALLEN φ10		1PC 1 PCE

STEP 1 / ÉTAPE 1

*Please check and make sure all the screws are tighten properly.

*Bien serrer tous les boulons

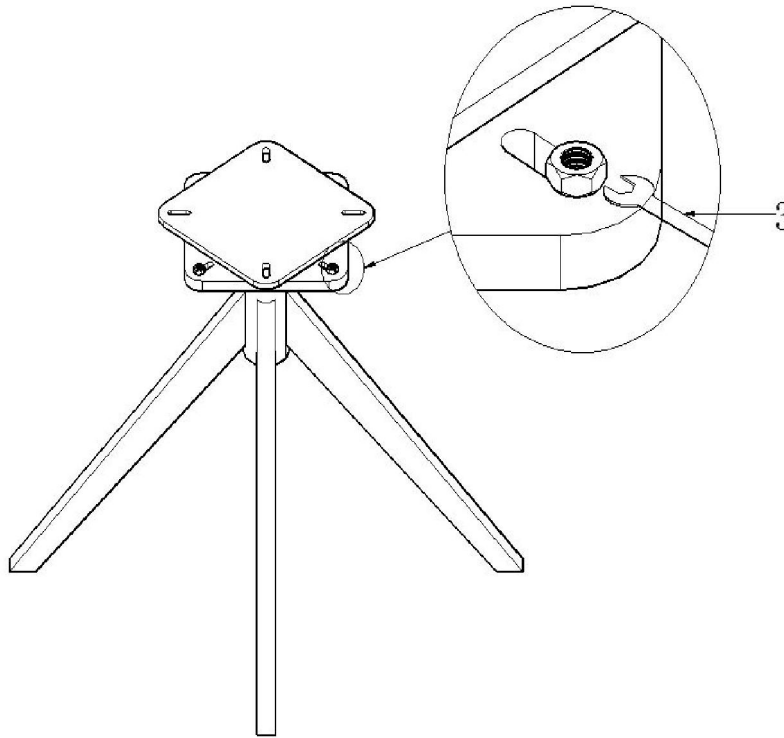

STEP 2 / ÉTAPE 2

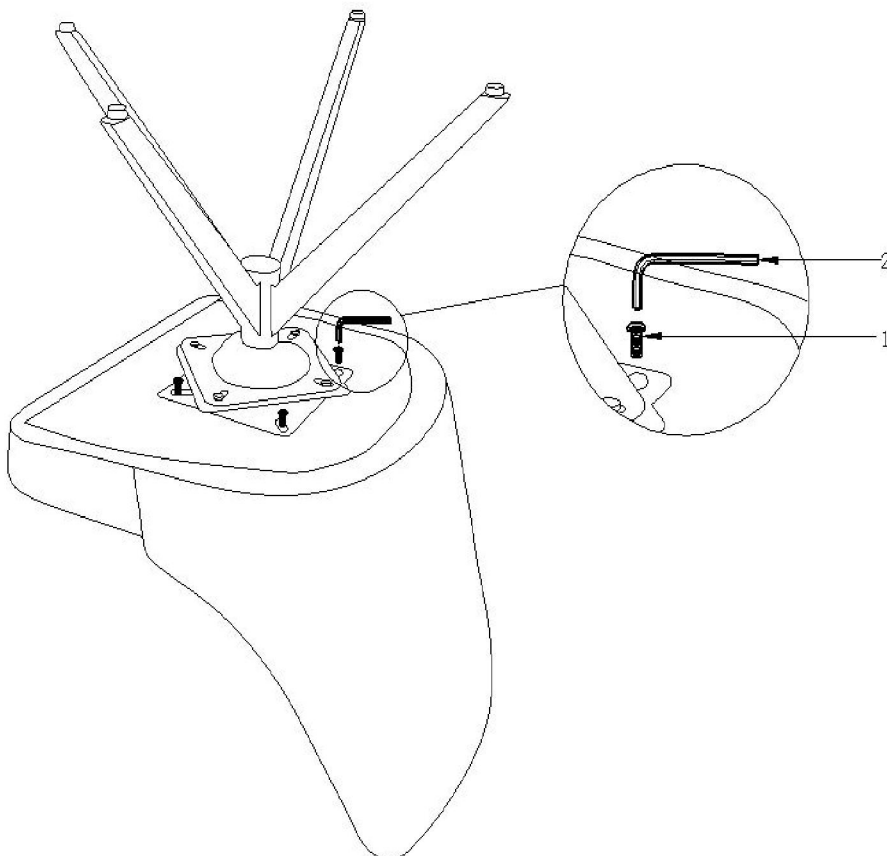

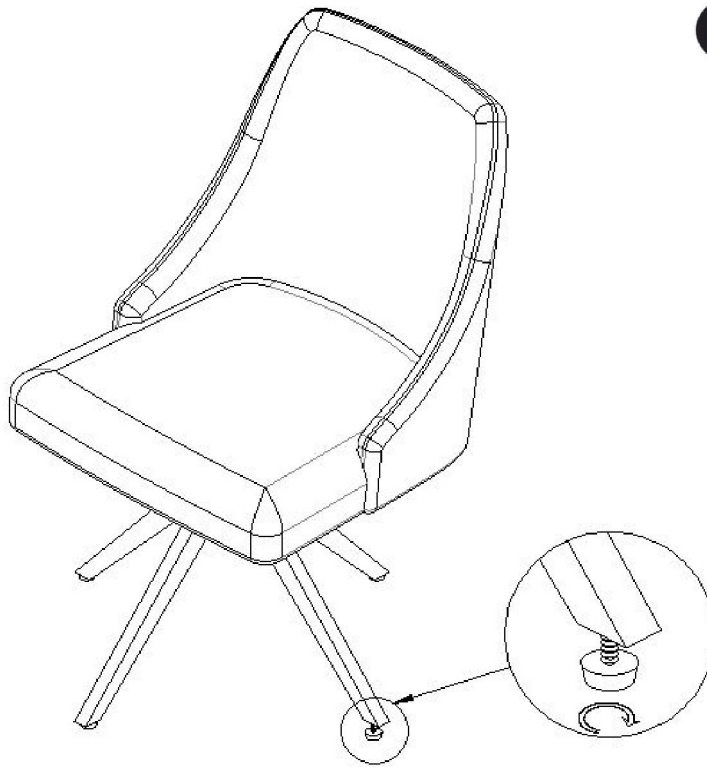

360° swivel base

