

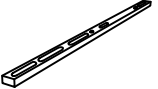

ASSEMBLY INSTRUCTIONS

**MODEL : DLB2302-DR/MR
DRESSER & MIRROR**





(Box 1)
BOX OF MIRROR

NO	ITEM	QTY
A	MIRROR 	1 pc
B	MIRROR SUPPORT RAIL 	2 pcs

(Box 2)
BOX OF DRESSER

NO	ITEM	QTY
C	DRESSER 	1 pc

(Box 1)
HARDWARE LIST

No	ITEM	Qty
1	JCBC M6 x 35mm Blk 	4 pcs
2	JCBC M6 x 40mm Blk 	4 pcs
3	Spring Washer 1/4" Blk 	8 pcs
4	Flat Washer 1/4"ID x 19mmOD Blk 	8 pcs
5	ALLEN KEY m4x65mm Blk 	1pc

STEP 1 : Take out mirror support (B) from the carton box .

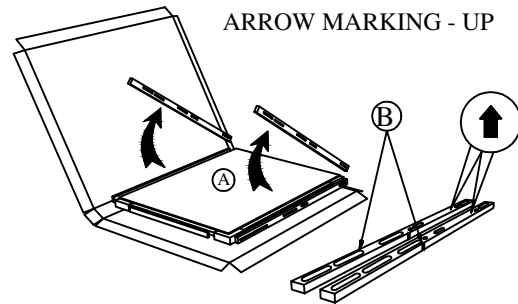

STEP 3 : Place mirror (A) on top of dresser (C). Align & fasten mirror support (B) to the back of dresser (C) using long JCBC bolt (2), spring washer (3) & flat washer (4) THEN FULLY TIGHTEN ALL THE BOLTS AT STEP 2 & 3 WITH ALLEN KEY (5).

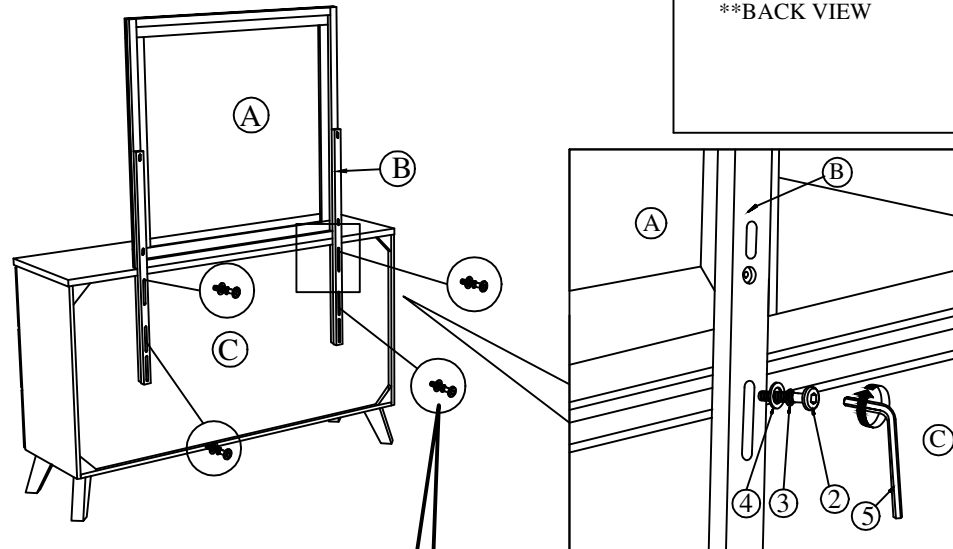

WARNING!
USE LONG BOLT M6 x 40mm



STEP 2 : Align & fasten mirror support (B) to the back of mirror (A) using short JCBC bolt(1),spring washer (3) & flat washer (4). DO NOT FULLY TIGHTEN AT THIS STEP.

Note : Make sure arrow marking of the mirror support (C) is aligned up.

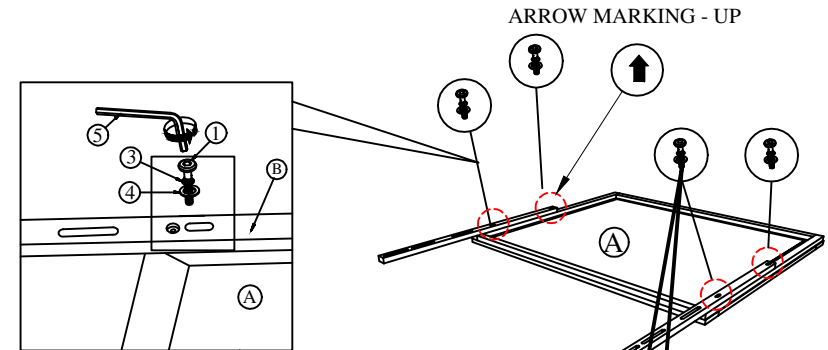

**BACK VIEW

WARNING!
USE LONG BOLT M6 x 35mm

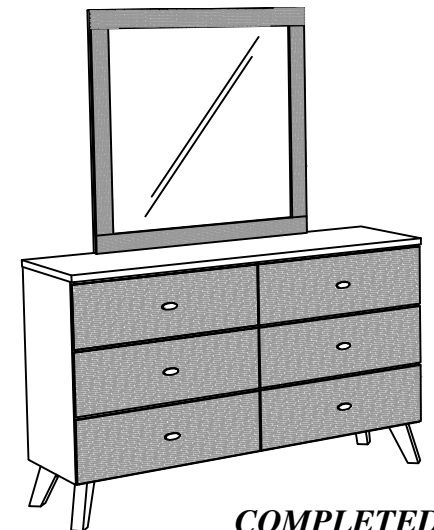

**COMPLETED
ASSEMBLY**

NOTE : MUST TIGHTEN SCREWS PERIODCALLY WITH USE SCREW WILL BECOME LOOSE CHECK TIGHTNESS OF ALL SCREW EVERY 6-8 WEEKS.

INSTRUCTIONS D'ASSEMBLAGE

MODELE : DLB2302-DR/MR
COMMODE & MIROIR

(Cart. 1)
CARTON MIROIR

N°	REF.	Qté
A	MIROIR	1 pce
B	RENFORT DU MIROIR	2 pces

(Cart. 2)
CARTON COMMODE

N°	REF.	Qté
C	COMMODE	1 pce

(Cart. 1) QUINCAILLERIE

N°	REF.	Qté
1	BOULON JCBC M6 x 35mm Nre	4 pces
2	BOULON JCBC M6 x 40mm Nre	4 pces
3	Rondelle à Ressort 1/4" Nre	8 pces
4	Rondelle Plate 1/4" Id X 19mm OD Nre	8 pces
5	CLE ALLEN m4 x 65mm Nre	1 pce

ETAPE 1: Enlever les renforts du miroir (B) du carton.

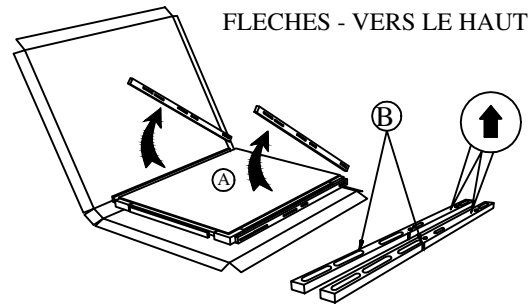

ETAPE 3 : Poser le miroir (A) sur la commode (C). Aligner et attacher le renfort (B) à l'arrière de la commode (B) en utilisant le boulon long JCBC (2), rondelle à ressort (3) & rondelle plate (4). PUIS, SERRER TOUS LES BOULONS DES ETAPES 2 & 3 AVEC LA CLE ALLEN (5).

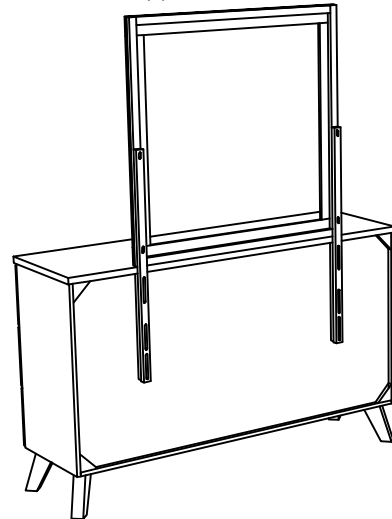

AVERTISSEMENT ! UTILISER
BOULON COURT M6 x 40mm



ETAPE 2: Aligner et attacher les renforts (B) à l'arrière du miroir (A) en utilisant le boulon JCBC court (1), rondelle à ressort (3) & rondelle plate (4). NE PAS SERRER COMPLETEMENT LORS DE CETTE ETAPE.

Remarque : S'assurer que les fleches du renforts (C) pointent vers le haut.
FLECHES - VERS LE HAUT

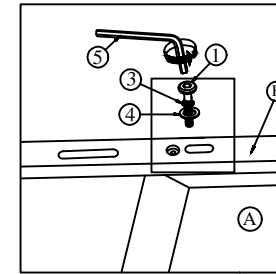

**VUE ARRIERE

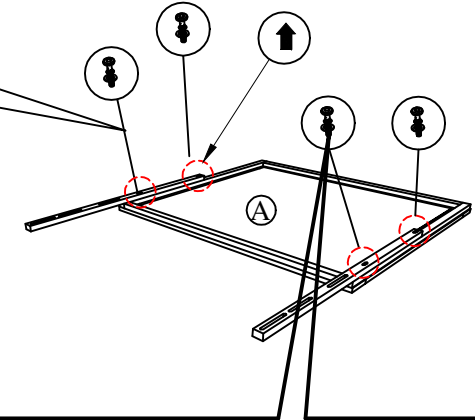

AVERTISSEMENT ! UTILISER
BOULON COURT M6 x 35mm

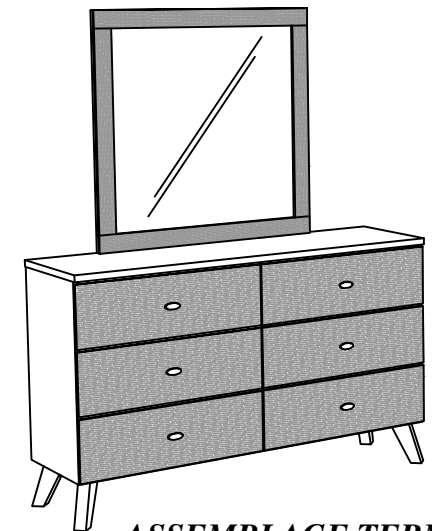

ASSEMBLAGE TERMINE