

ASSEMBLY INSTRUCTIONS / NOTICE D'ASSEMBLAGE

ITEM NO : JYP-1863 BBT/AST3CCTL

Important note/ Note importante:

1. Place all wooden parts on a clean and smooth surface such as a rug or carpet to avoid scratching the parts. / Placer les pièces sur une surface propre et lisse tel qu'une couverture ou un tapis pour éviter d'endommager les pièces.
2. Kindly follow the assembly instructions step by step./ Veuillez suivre la notice d'assemblage, pas à pas.
3. Do not tighten all screws and bolts until the table is fully assembled./ Ne serrer les vis et boulons à fond que lorsque le produit est entièrement assemblé.
4. Unscrew the protective plastic supports from the metal insert of the table legs before assembly./ Dévisser les caches plastiques des embouts métalliques des pieds de la table avant l'assemblage.

PARTS IDENTIFICATION / IDENTIFICATION DES PIÈCES

A Table Top
Dessus de table



1pc

B Table storage panel
Panneau de avec rangement



1pc

C Table shelf
Étagère



3pcs

D Table Leg
Pieds



1pc

E Table Leg
Pieds



1pc

F Table Leg
Pied

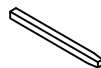

1pc

G Table Leg
Pieds

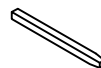

1pc

H Stretcher
Traverse



1pc

I Side stretcher
Traverse côté



1pc

HARDWARE IDENTIFICATION / IDENTIFICATION DES PIÈCES MONTAGE

1 Bolt
Boulon

1/4"X38mm



8pcs

2 Long Bolt
Boulon long

5/16"X60mm



8pcs

3 T Metal bracket
T équerres de métal

50x40x2.0



1pc

4 Spring Washer
Rondelle D'arrêt

5/16"X11mm



16 pcs

5 Flat Washer
Rondelle Plate

5/16"X19mm

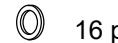

16 pcs

6 Allen Key
Clé Allen



1pc

7 wood screw
/Vis

3x12mm



18pcs

8 wood screw
Vis

4x45mm



2pcs

9 L Metal bracket
L équerres de métal



1pc

10 Shelf Bracket
Étagère équerres



12pcs

STEP 1 / ÉTAPE 1

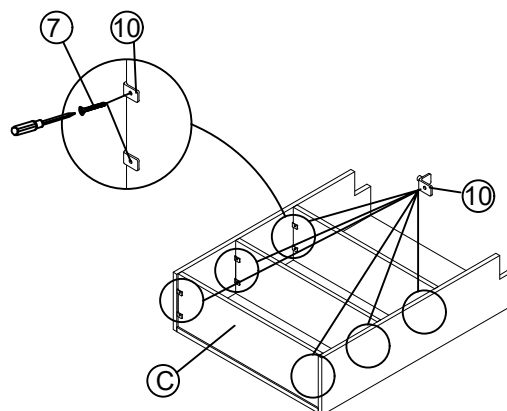
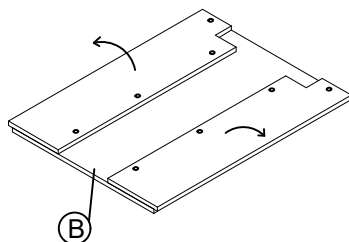

ASSEMBLY INSTRUCTIONS / NOTICE D'ASSEMBLAGE

ITEM NO : JYP-1863 BBT/AST3CCTL

STEP 2 / ÉTAPE 2

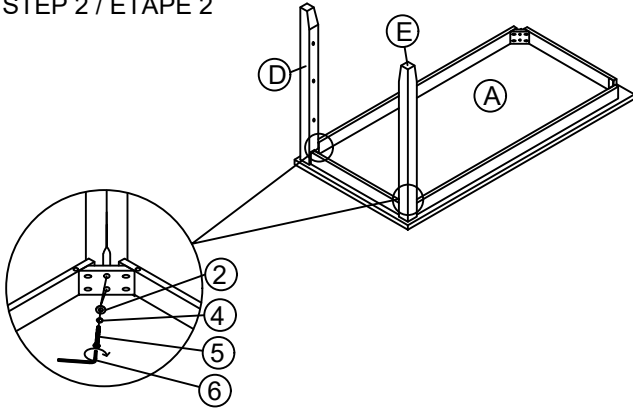

STEP 3 / ÉTAPE 3

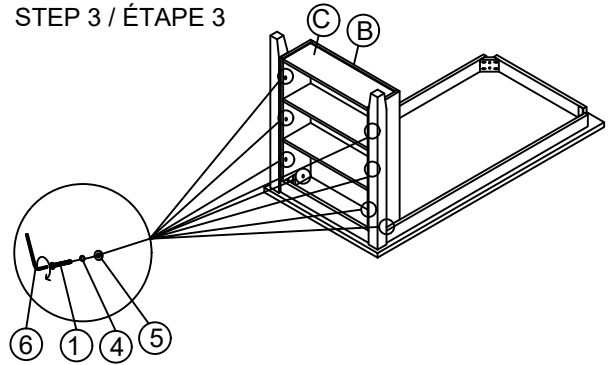

STEP 4 / ÉTAPE 4

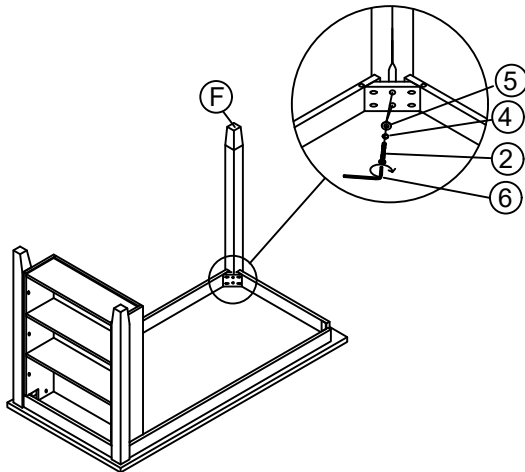

STEP 5 / ÉTAPE 5

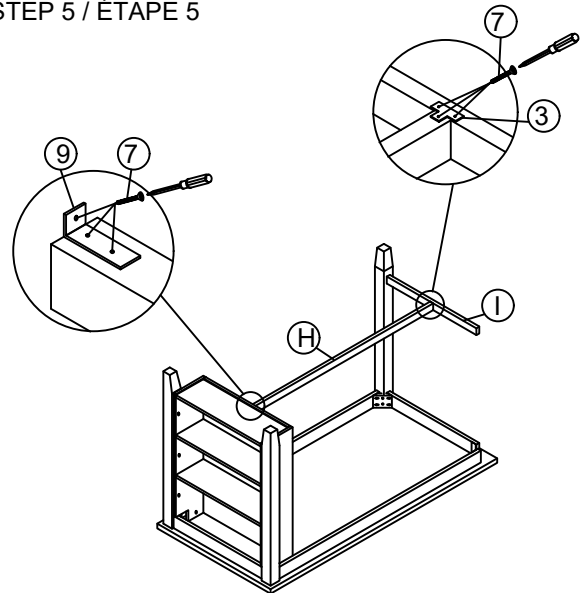

STEP 6 / ÉTAPE 6

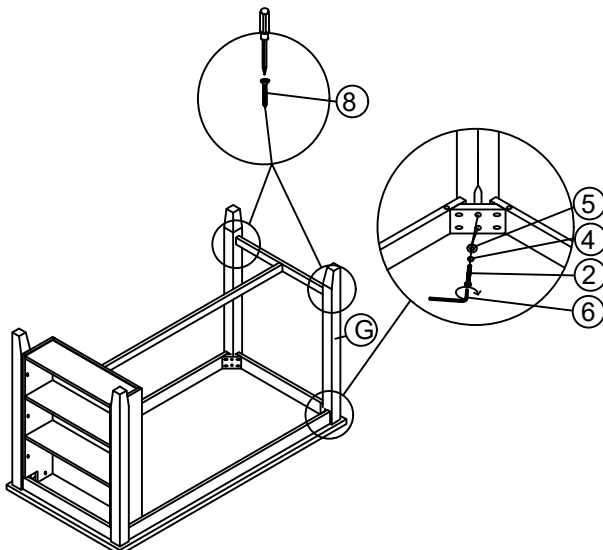

COMPLETE/ ASSEMBLAGE TERMINÉ

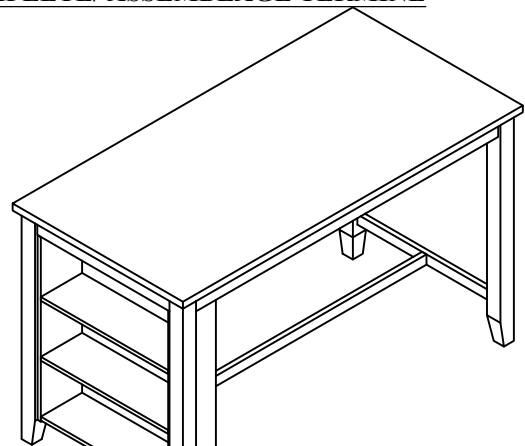

ADJUSTABLE LEVELER/
PATIN RÉGLABLE