

ASSEMBLY INSTRUCTIONS / NOTICE D'ASSEMBLAGE

ITEM: JYP-1861 BRT, JYP-1891 BRG/CHE3RDTL & CHELGRTL

Important note/ Note importante:

1. Place all wooden parts on a clean and smooth surface such as a rug or carpet to avoid scratching the parts. / Placer les pièces sur une surface propre et lisse tel qu'une couverture ou un tapis pour éviter d'endommager les pièces.
2. Kindly follow the assembly instructions step by step./ Veuillez suivre la notice d'assemblage, pas à pas.
3. Do not tighten all screws and bolts until the table is fully assembled./ Ne serrer les vis et boulons à fond que lorsque le produit est entièrement assemblé.
4. Unscrew the protective plastic supports from the metal insert of the table legs before assembly./ Dévisser les caches plastiques des embouts métalliques des pieds de la table avant l'assemblage.

PARTS IDENTIFICATION / IDENTIFICATION DES PIÈCES

A Table Top
Dessus de Table

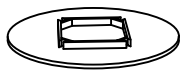

1pc

B Table Leg-A
Pattes-A



1pc

C Table Leg-B
Pattes-B

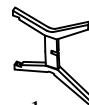

1pc

HARDWARE IDENTIFICATION / IDENTIFICATION DES PIÈCES MONTAGE

1 Bolt
Boulon

5/16"X50mm



8pcs

2 Long Bolt
Boulon long

1/4"X65mm



1pc

3 Spring Washer
Rondelle D'arret

5/16"X11mm



9 pcs

4 Flat Washer
Rondelle Plate

5/16"X19mm



9 pcs

5 Allen Key
Clé Allen

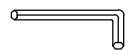

1pc

STEP 1 / ÉTAPE 1

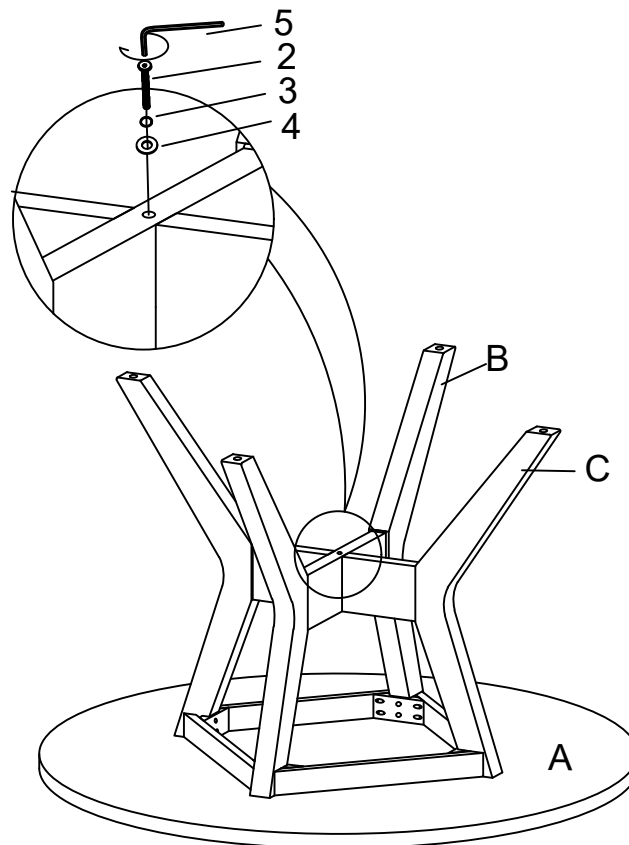

ASSEMBLY INSTRUCTIONS / NOTICE D'ASSEMBLAGE
ITEM: JYP-1861 BRT, JYP-1891 BRG/CHE3RDTL&CHELGRTL

STEP 2 / ÉTAPE 2

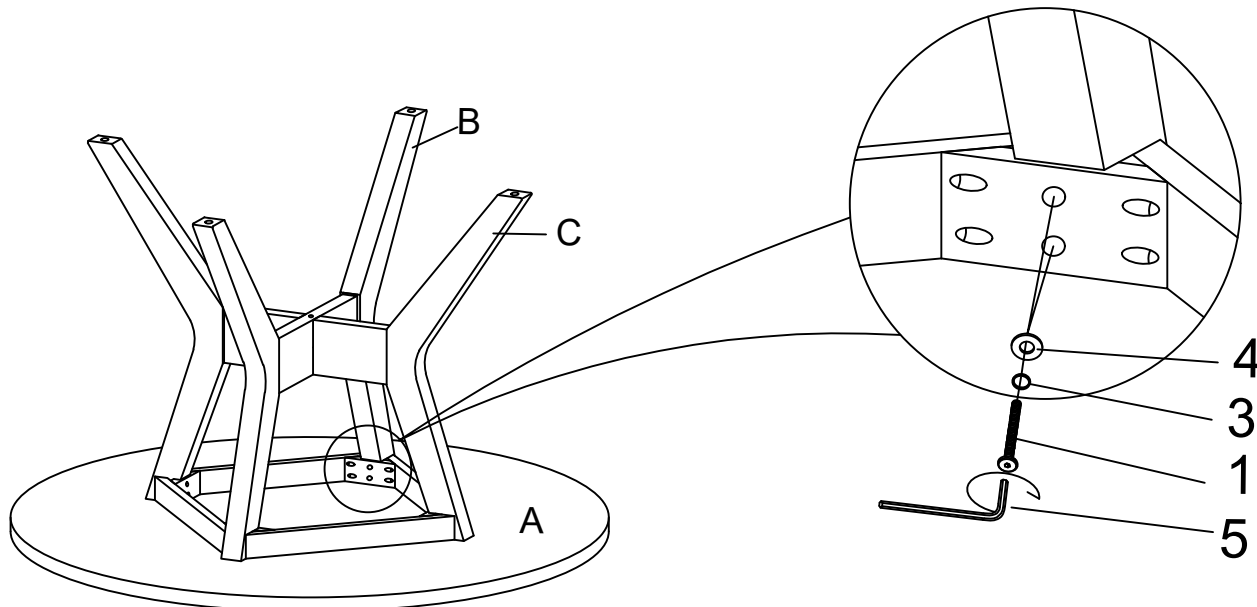

COMPLETE

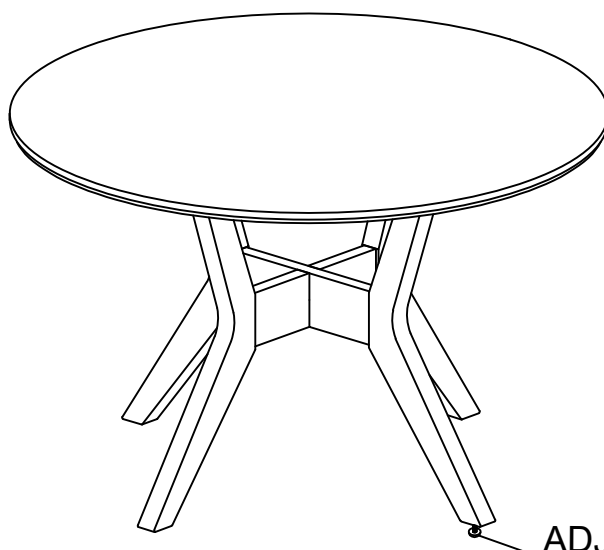

ADJUSTABLE LEVELER/
PATIN RÉGLABLE