

ASSEMBLY INSTRUCTIONS / NOTICE D'ASSEMBLAGE

ITEM: JYP-1863 BB2/AST3CCST

Important note/ Note importante:

1. Place all wooden parts on a clean and smooth surface such as a rug or carpet to avoid scratching the parts. / Placer les pièces sur une surface propre et lisse tel qu'une couverture ou un tapis pour éviter d'endommager les pièces.
2. Kindly follow the assembly instructions step by step./ Veuillez suivre la notice d'assemblage, pas à pas.
3. Do not tighten all screws and bolts until the table is fully assembled./ Ne serrer les vis et boulons à fond que lorsque le produit est entièrement assemblé.
4. Unscrew the protective plastic supports from the metal insert of the table legs before assembly./ Dévisser les caches plastiques des embouts métalliques des pieds de la table avant l'assemblage.

PARTS IDENTIFICATION / IDENTIFICATION DES PIÈCES

A Seat cushion
Coussin assise

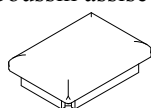

1pc

B Left Leg
Pied gauche

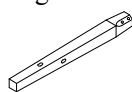

2pcs

C Right Leg
Pied Droite

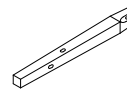

2pcs

D Left Right Stretcher
Traverse côté gauche



2pcs

E Front Behind Stretcher
Traverse Avant



2pcs

HARDWARE IDENTIFICATION / IDENTIFICATION DES PIÈCES MONTAGE

1 Bolt
Boulon

1/4"X60mm



8pcs

2 Spring Washer
Rondelle D'arret

1/14"X11mm

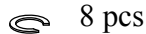

8 pcs

3 Flat Washer
Rondelle Plate

1/4"X19mm

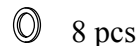

8 pcs

4 Allen Key
Clé Allen



1pc

5 Wood screw
Vis
4X38mm



8pcs

STEP 1 / ÉTAPE 1

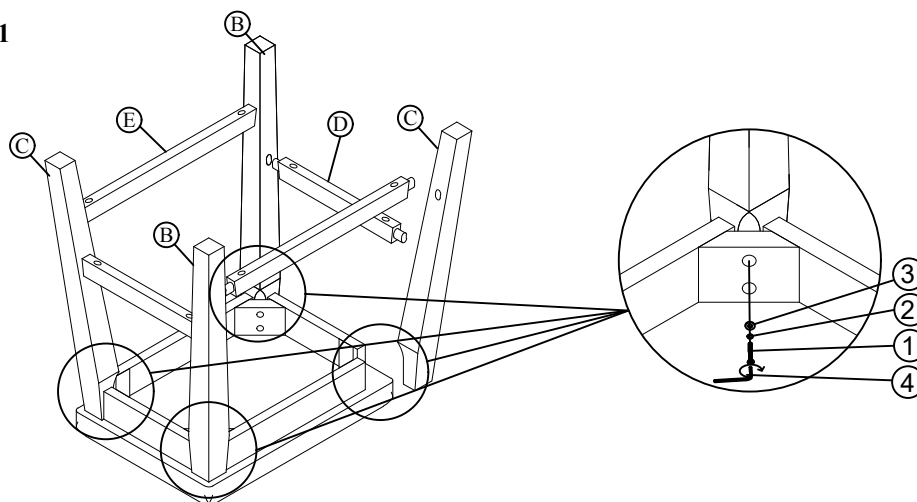

ASSEMBLY INSTRUCTIONS / NOTICE D'ASSEMBLAGE
ITEM: JYP-1863 BB2/AST3CCST

STEP 2 / ÉTAPE 2

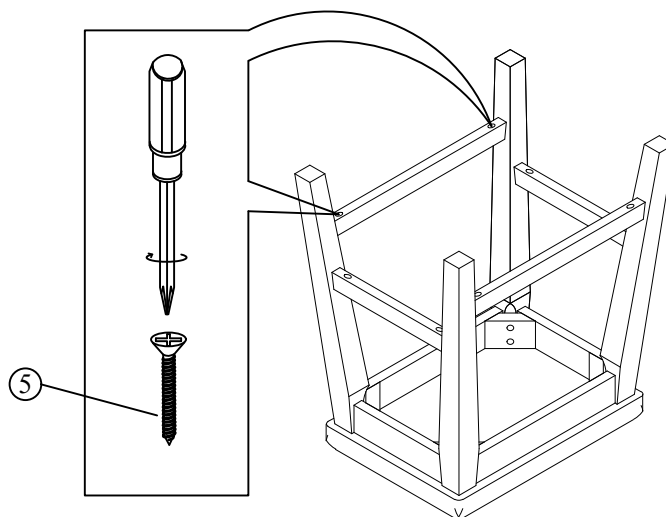

COMPLETE/ ASSEMBLAGE TERMINÉ

