







ASSEMBLY INSTRUCTIONS (INSTRUCTIONS D'ASSEMBLAGE)

HARDWARE LIST (LISTE DES OUTILS):

NO.	SKETCH	DESCRIPTION	QTY
A		Bolt(1/4"*1-1/8") Boulon	4 PCS
B		Washer(1/4") Rondelle plate	4 PCS
C		Spring Washer(1/4") Rondelle frein	4 PCS
D		Allen wrench(4mm) Clé hexagonale	1 PC

PARTS LIST (LISTE DES PIECES):

NO.	SKETCH	DESCRIPTION	QTY
1		Seat Siège	1 PC
2		Metal Base Base en métal	1 PC

Step 1 / Étape 1

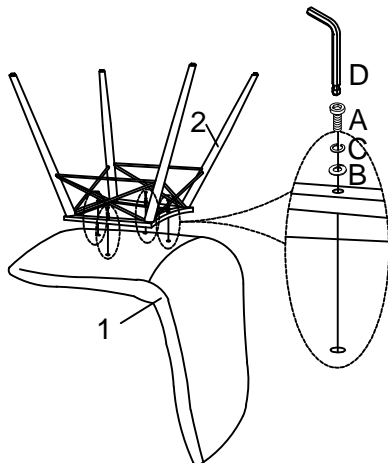

Step 2 / Étape 2

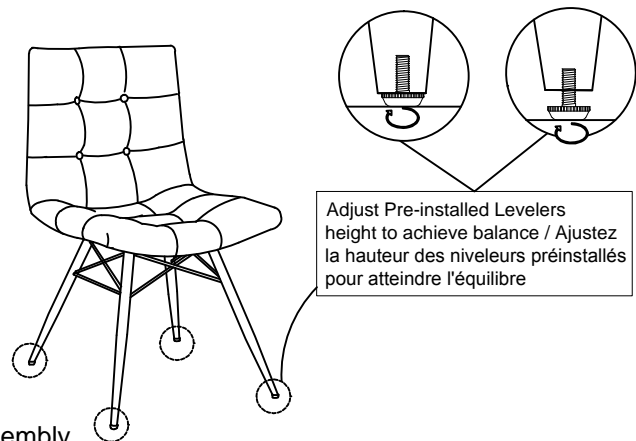

Note: Do not full tighten all bolts until complete assembly.
Tel qu' illustré. Attendre avant de serrer complètement les boulons.

Step 3 / Étape 3

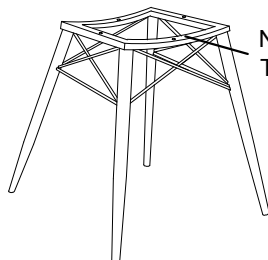

Note: This is front
Tel qu' illustré. Face avant

Step 4 / Étape 4

