

ASSEMBLY INSTRUCTIONS / INSTRUCTIONS D'ASSEMBLAGE

ITEM NO/NO ARTICLE: ARIBK3PK/161602A-X3
ARICR3PK/161602B-X3

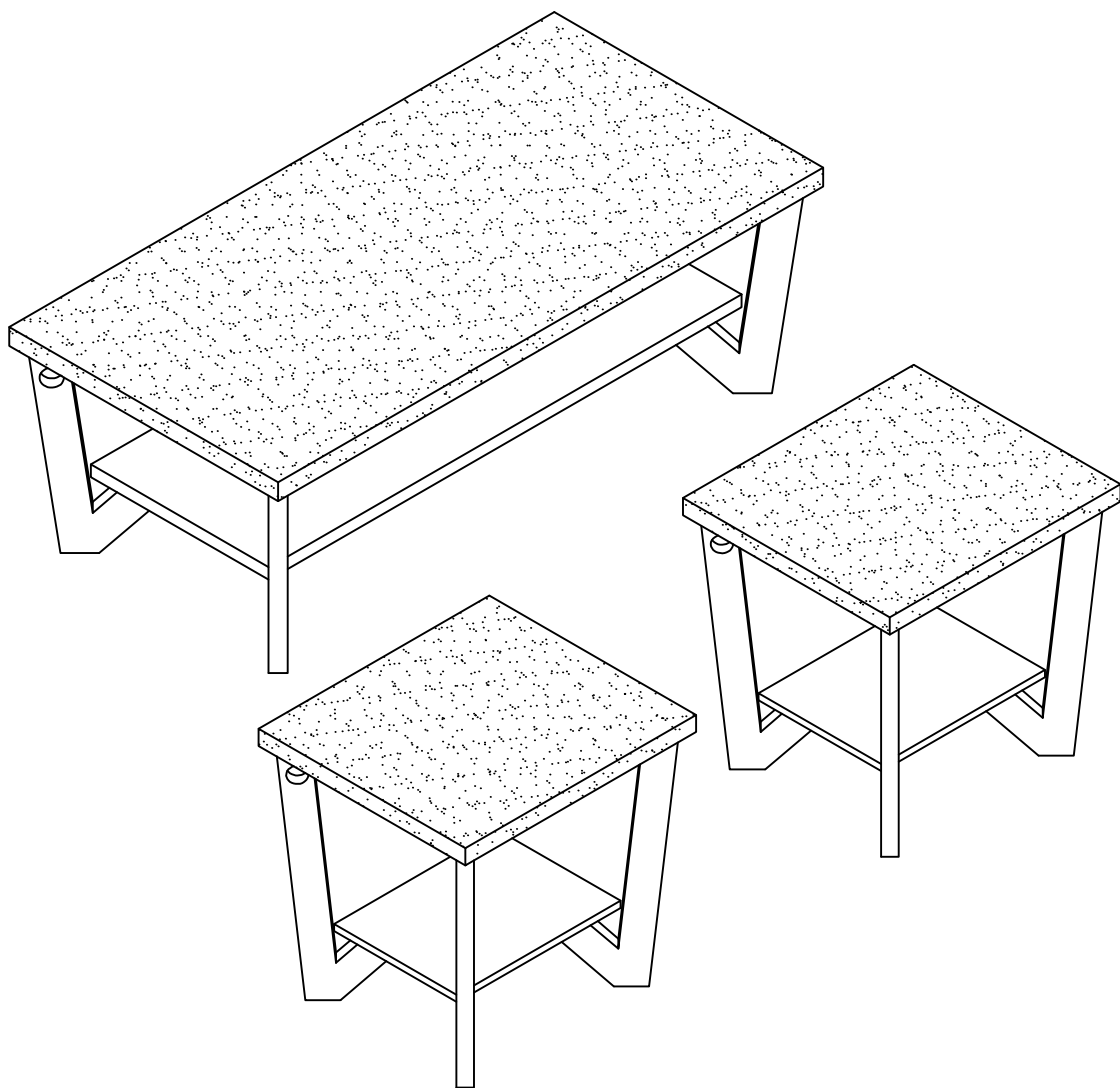

PARTS IDENTIFICATIONS / IDENTIFICATION DES PIECES



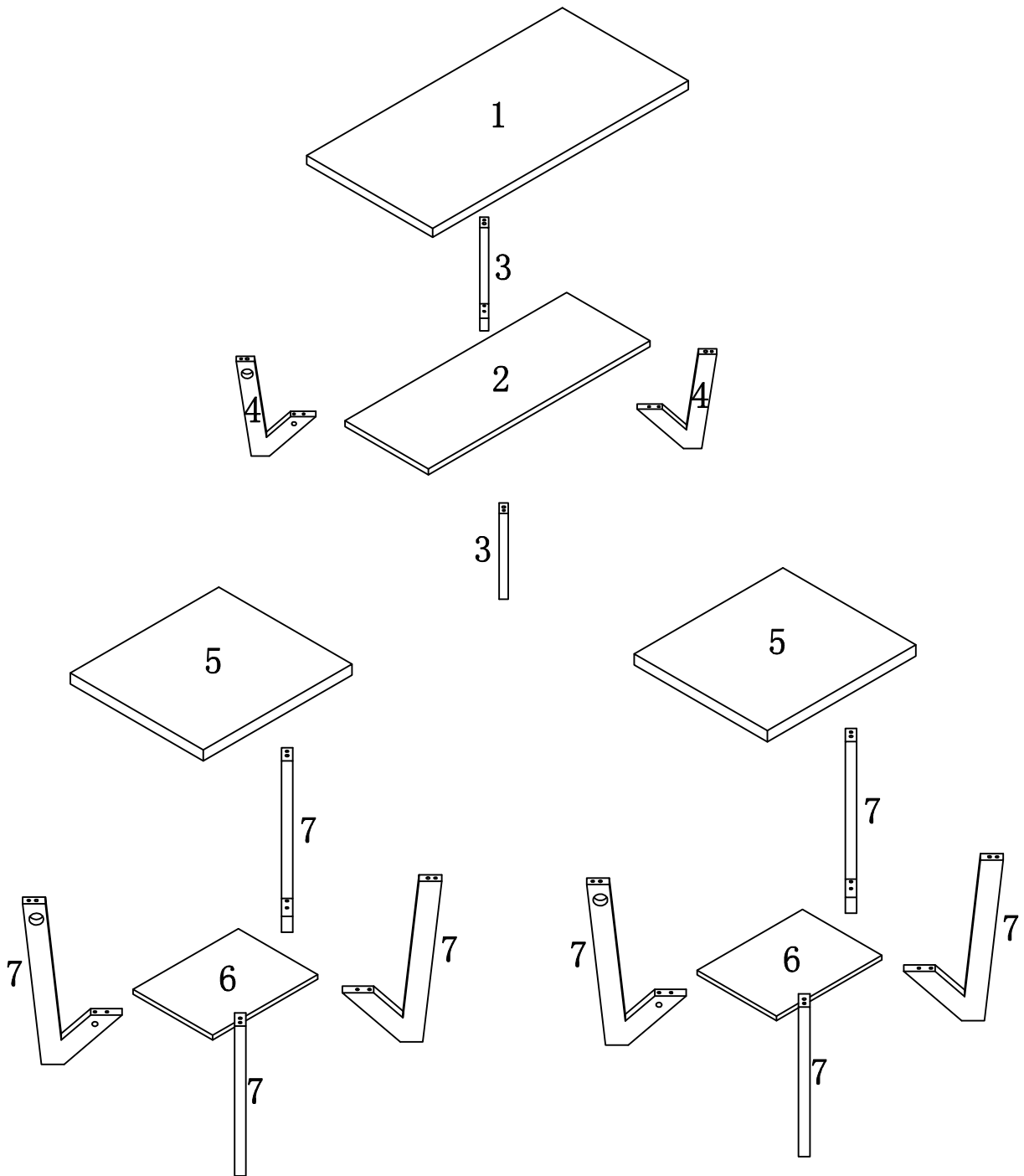







ITEM NO/NO ARTICLE: ARI BK3PK/161602A-X3
ARI CR3PK/161602B-X3



(1)	1pc	(5)	2pcs
(2)	1pc	(6)	2pcs
(3)	2pcs	(7)	8pcs
(4)	2pcs		

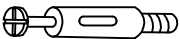

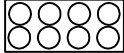
HARDWARE IDENTIFICATIONS/ IDENTIFICATION DU KIT D'ASSEMBLAGE

ITEM NO/NO ARTICLE: ARI BK3PK/161602A-X3
ARI CR3PK/161602B-X3

A		M8x70	12pcs
B		∅8x25	24pcs
C		M8	12pcs
D		∅8x∅16x2	12pcs
E		M8	12pcs
F		∅45	12pcs
G		M13	1pc
H		L29	12pcs
I		∅15	12pcs
J		∅20	12pcs
K		∅16	12pcs
L		Glue: For securing please apply to wood dowel first before inserting into panel	1pc

ASSEMBLY INSTRUCTION

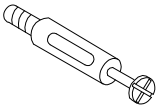
ITEM#: 161602A-X3 161602B-X3

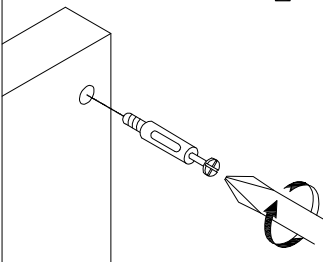
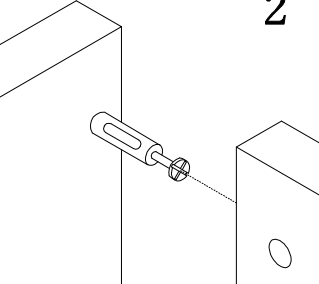
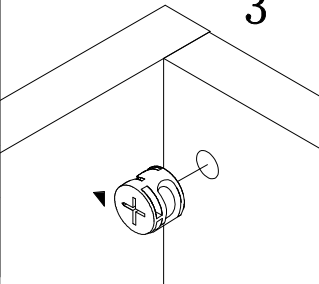
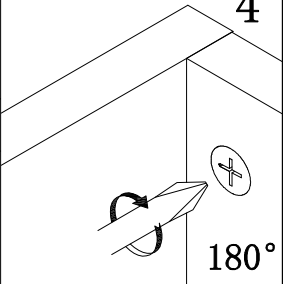
<p>HOW TO</p>  <p>Cam Bolt</p>  <p>Cam Lock</p>	<p>1</p>  <p>1. Screw Cam Bolt into panel.</p>	<p>2</p>  <p>2. Insert Cam Bolt into bolt hole of joining panel.</p>	<p>3</p>  <p>3. Insert Cam Lock. arrow facing bolt.</p>	<p>4</p>  <p>4. Gently turn Cam Lock clockwise to lock position.</p> <p>180°</p>
--	---	---	---	---

ITEM NO/NO ARTICLE: ARI BK3PK/161602A-X3
ARI CR3PK/161602B-X3

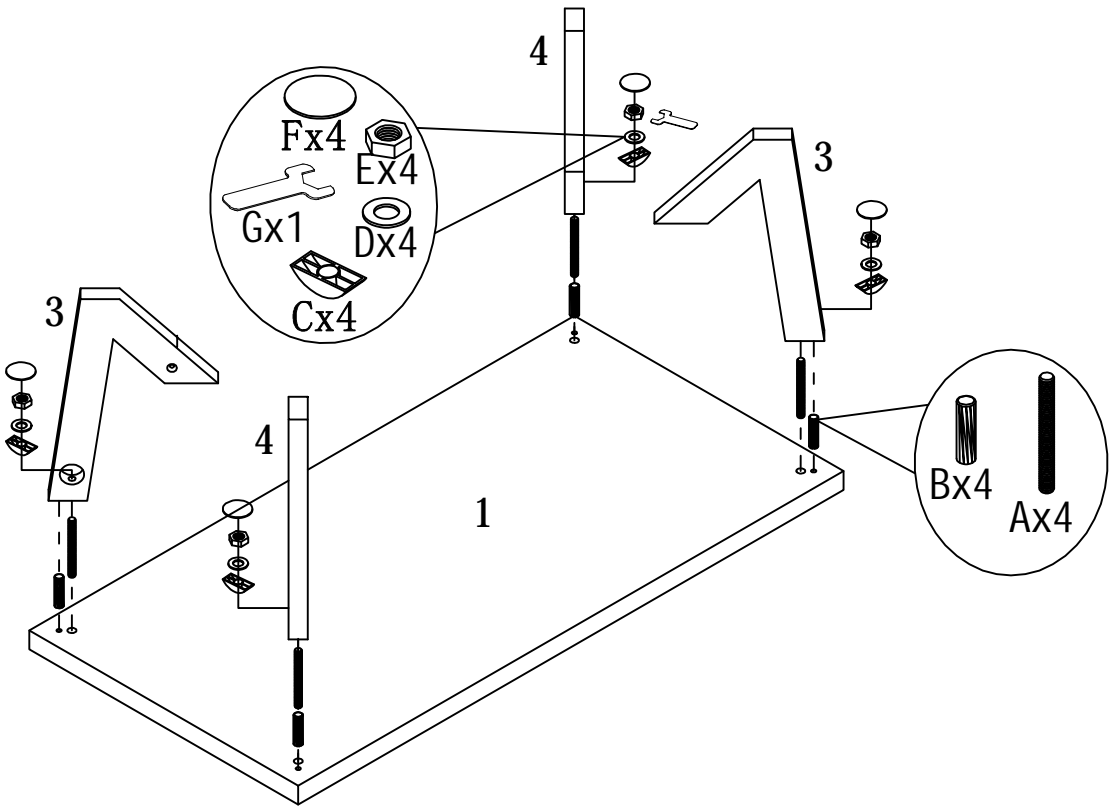

STEP 1

STEP 2

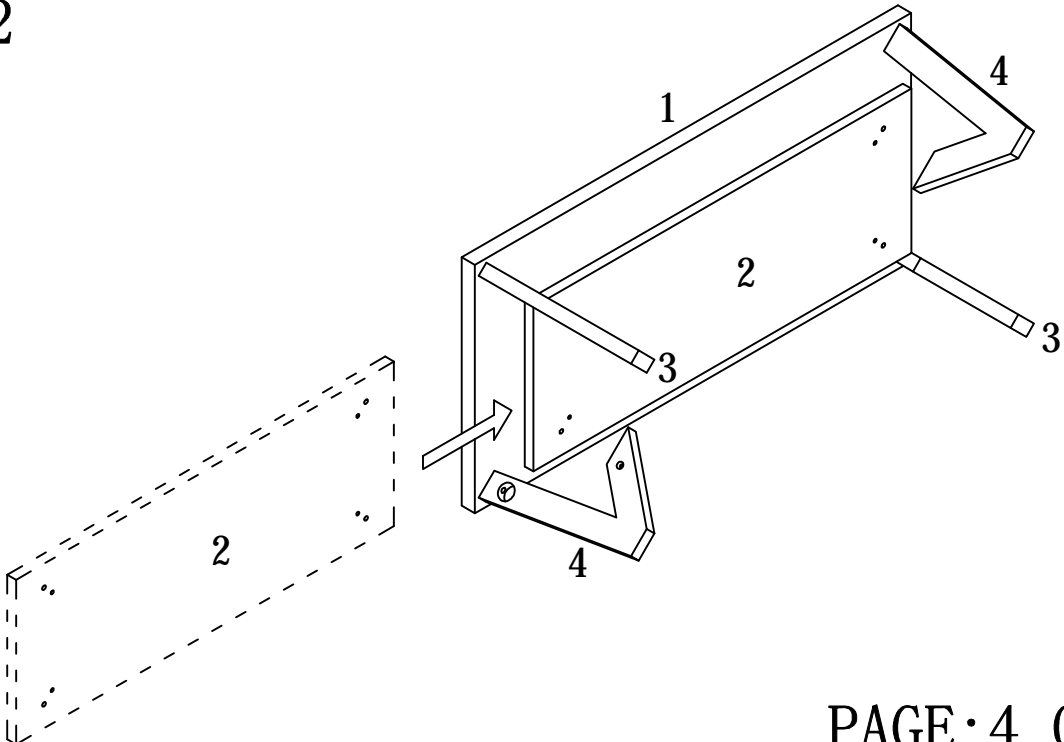

ITEM NO/NO ARTICLE: ARI BK3PK/161602A-X3
ARI CR3PK/161602B-X3

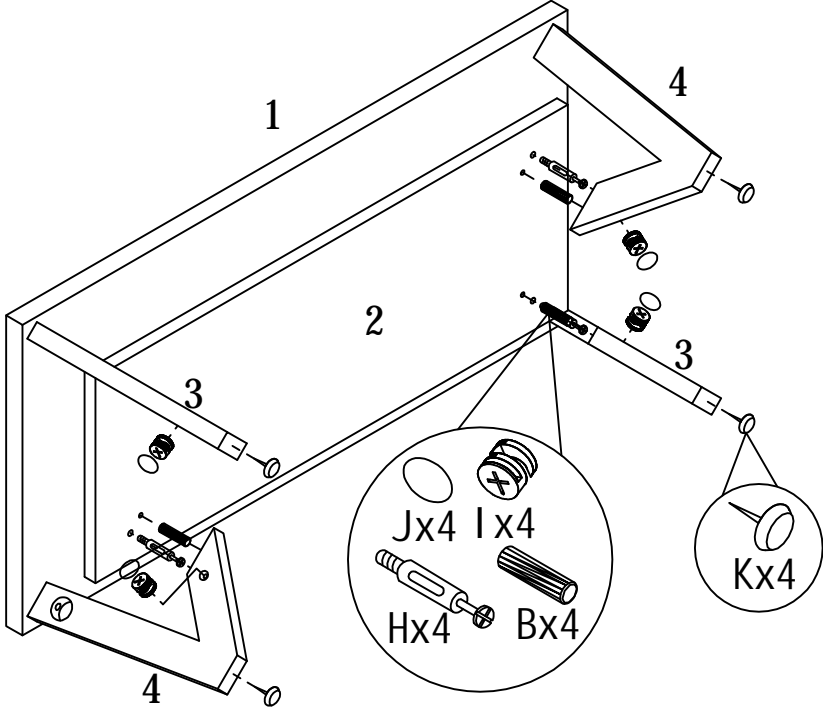

STEP3

STEP4

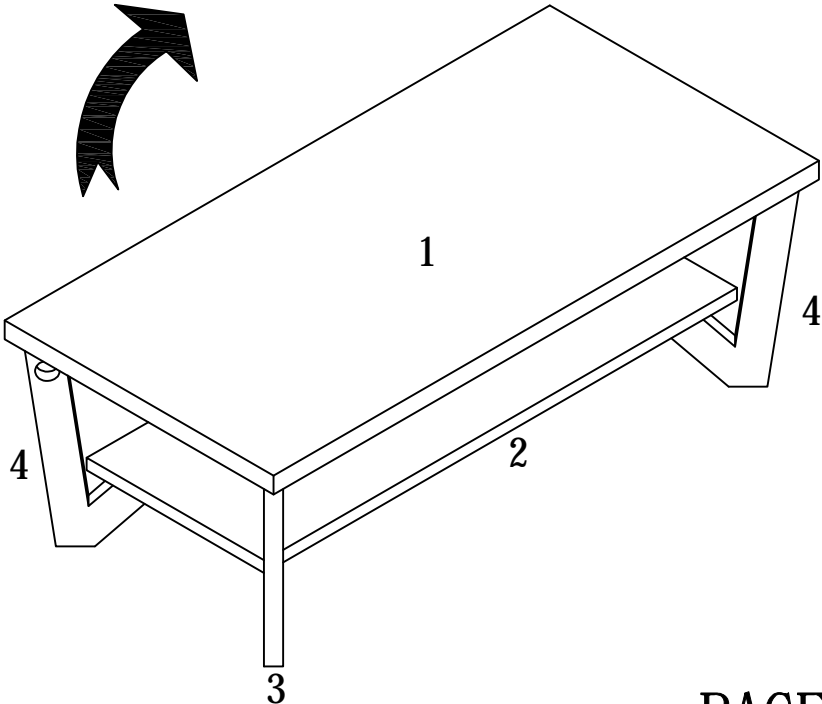

ITEM NO/NO ARTICLE: ARI BK3PK/161602A-X3
ARI CR3PK/161602B-X3

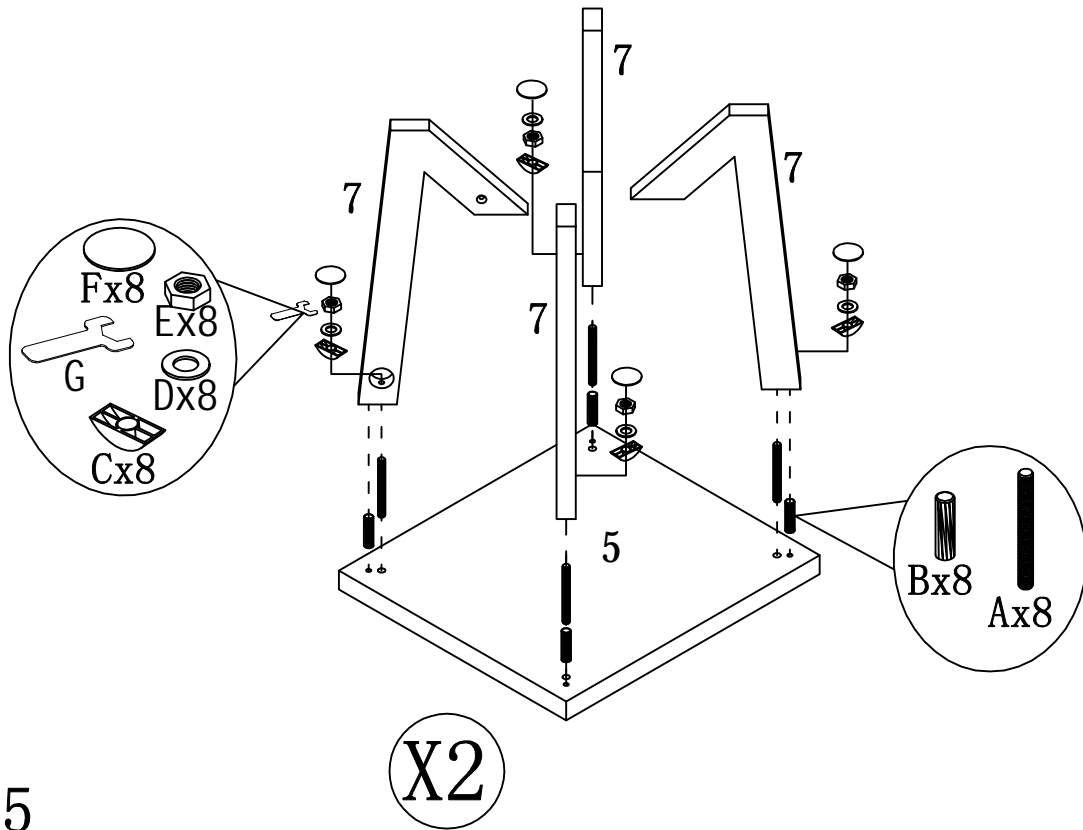

STEP5

STEP6

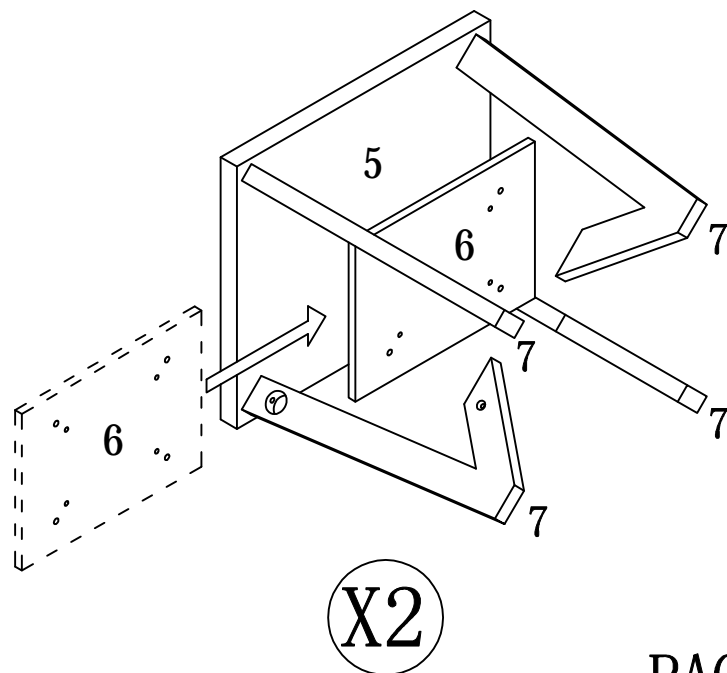

ITEM NO/NO ARTICLE: ARI BK3PK/161602A-X3
ARI CR3PK/161602B-X3

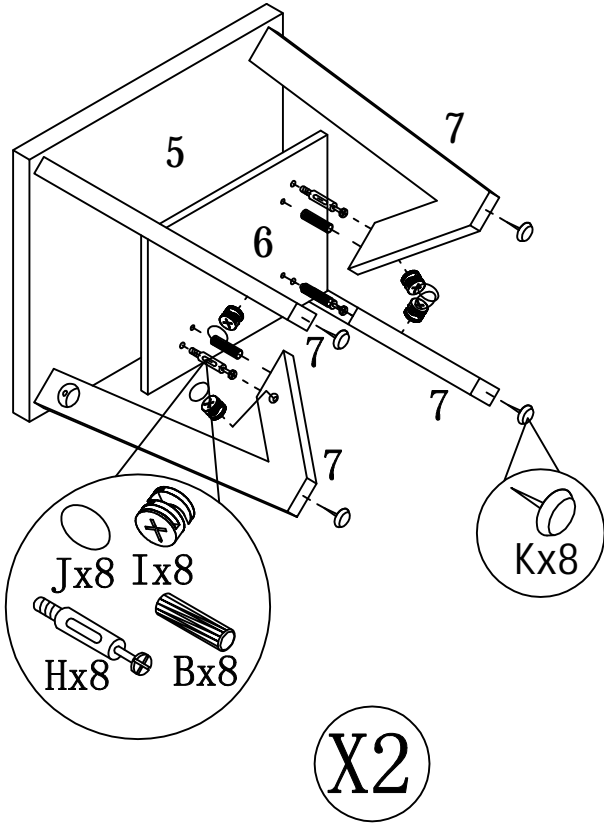

STEP7

STEP8

