













ASSEMBLY INSTRUCTIONS(INSTRUCTIONS D'ASSEMBLAGE)

HARDWARE LIST (LISTE DES OUTILS):

NO.	SKETCH	DESCRIPTION	QTY
A		Bolt(Ø1/4" * 1-1/4") Boulon	20PCS
B		Bolt(Ø1/4" * 3/4") Boulon	24PCS
C		Spring Washer(Ø1/4") Rondelle frein	20PCS
D		Washer(Ø1/4") Rondelle plate	20PCS
E		Allen wrench(4mm) Clé hexagonale	1PC
F		Bracket Support	6PCS
G		Glass Shelf Support Support pour tablette en	12PCS

PARTS LIST (LISTE DES PIECES):

NO.	SKETCH	DESCRIPTION	QTY
1		Top Panel Panneau supérieur	1PC
2		Bottom Panel Panneau inférieur	1PC
3		Front Side Leg Patte avant de côté	2PCS
4		Front Middle Leg Patte avant centrale	1PC
5		Back Side Leg Patte arrière de côté	2PCS
6		Back Middle Leg Patte arrière centrale	1PC
7		Back Panel Panneau arrière	2PCS
8		Glass Shelf Tablette en verre	2PCS
9		Adapter Adapteur	1PC

Step 1 / Étape 1

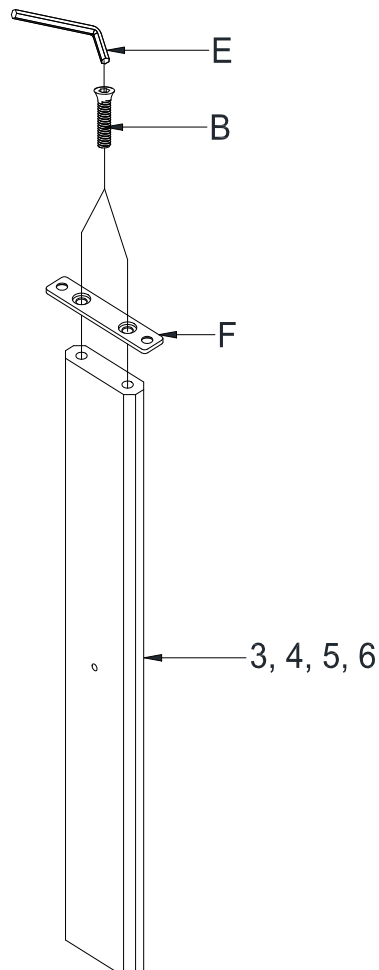

ASSEMBLY INSTRUCTIONS(INSTRUCTIONS D'ASSEMBLAGE)

Step 2 / Étape 2

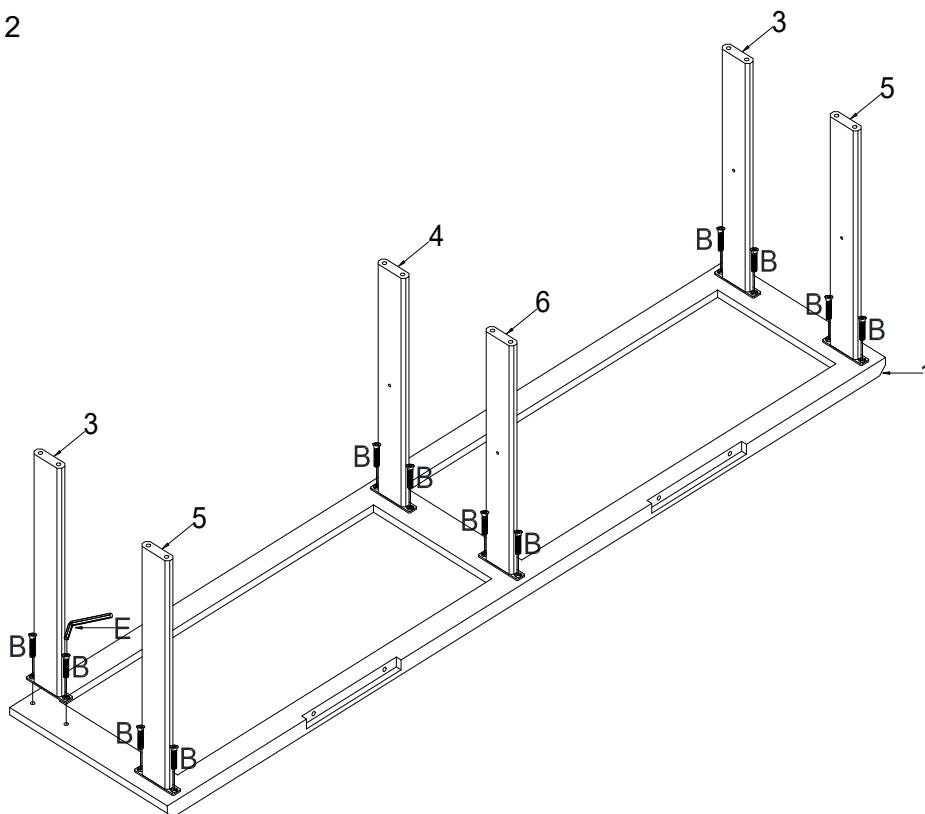

Step 3 / Étape 3

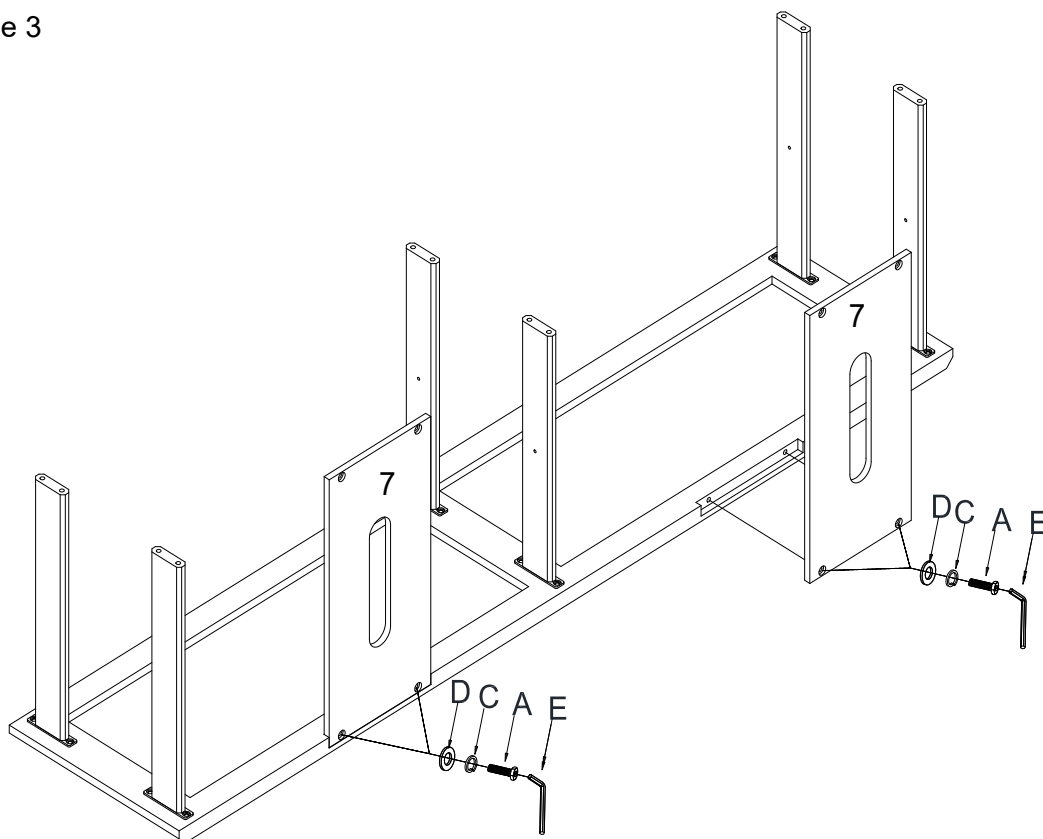

ASSEMBLY INSTRUCTIONS(INSTRUCTIONS D'ASSEMBLAGE)

Step 4 / Étape 4

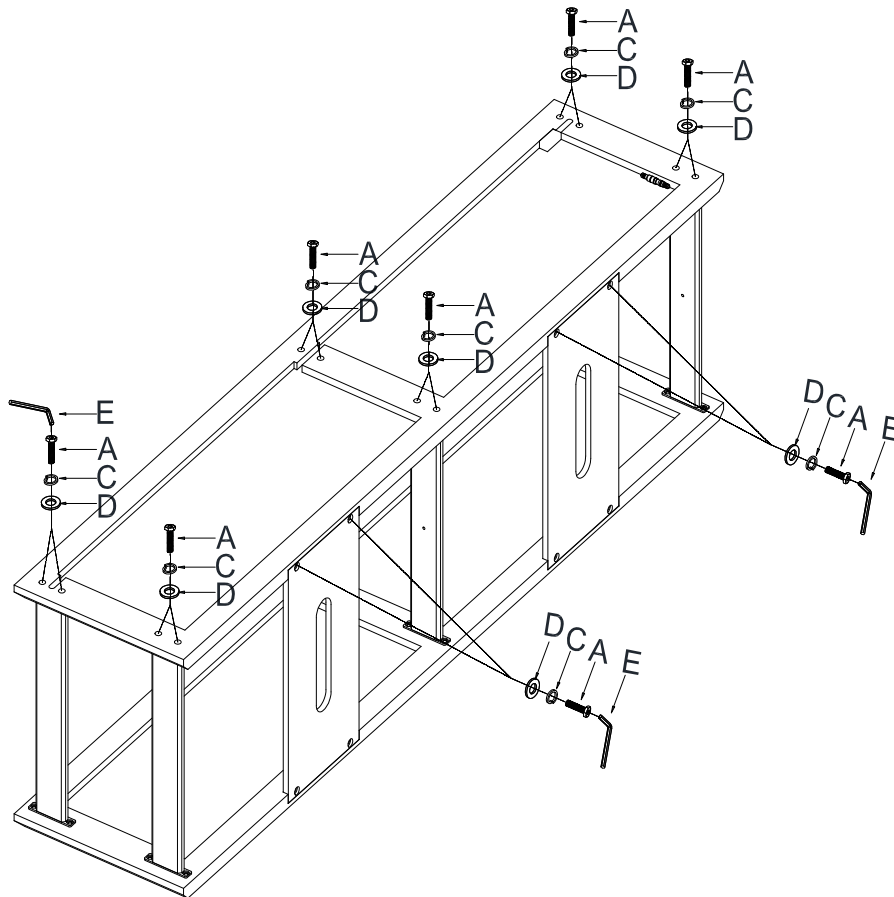

Step 5 / Étape 5

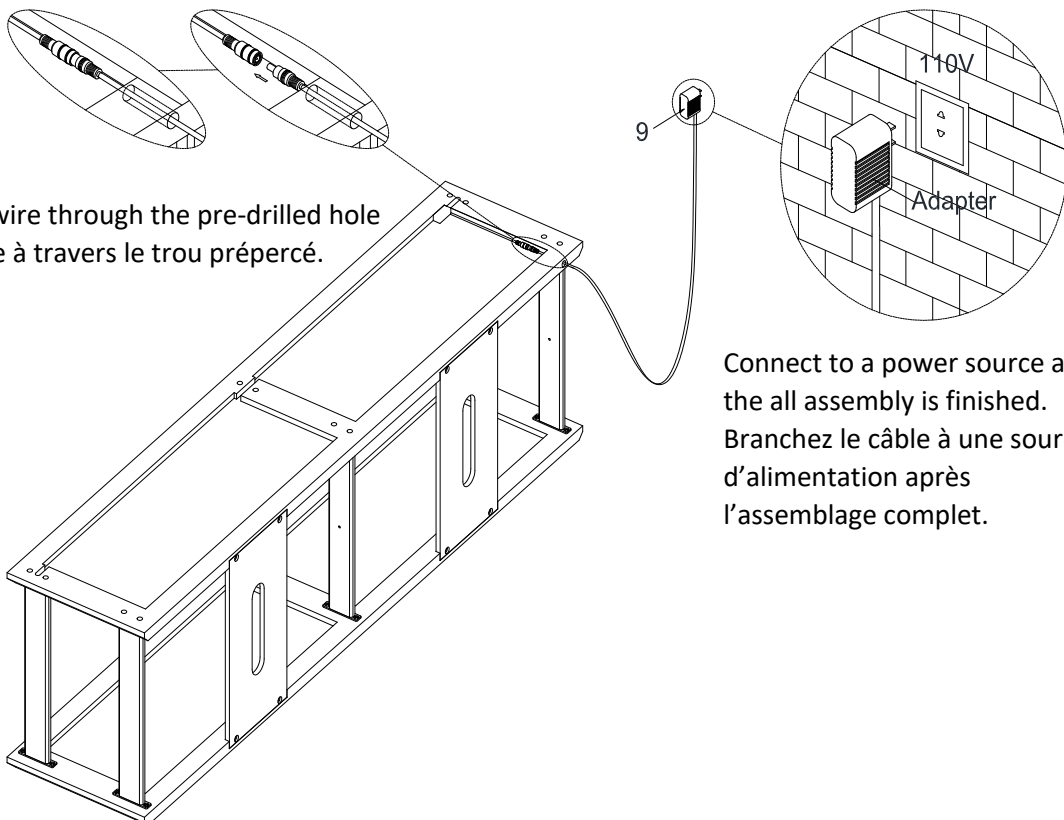

Connect the wire through the pre-drilled hole
Passez le câble à travers le trou prépercé.

Connect to a power source after
the all assembly is finished.
Branchez le câble à une source
d'alimentation après
l'assemblage complet.

ASSEMBLY INSTRUCTIONS(INSTRUCTIONS D'ASSEMBLAGE)

Step 6 / Étape 6

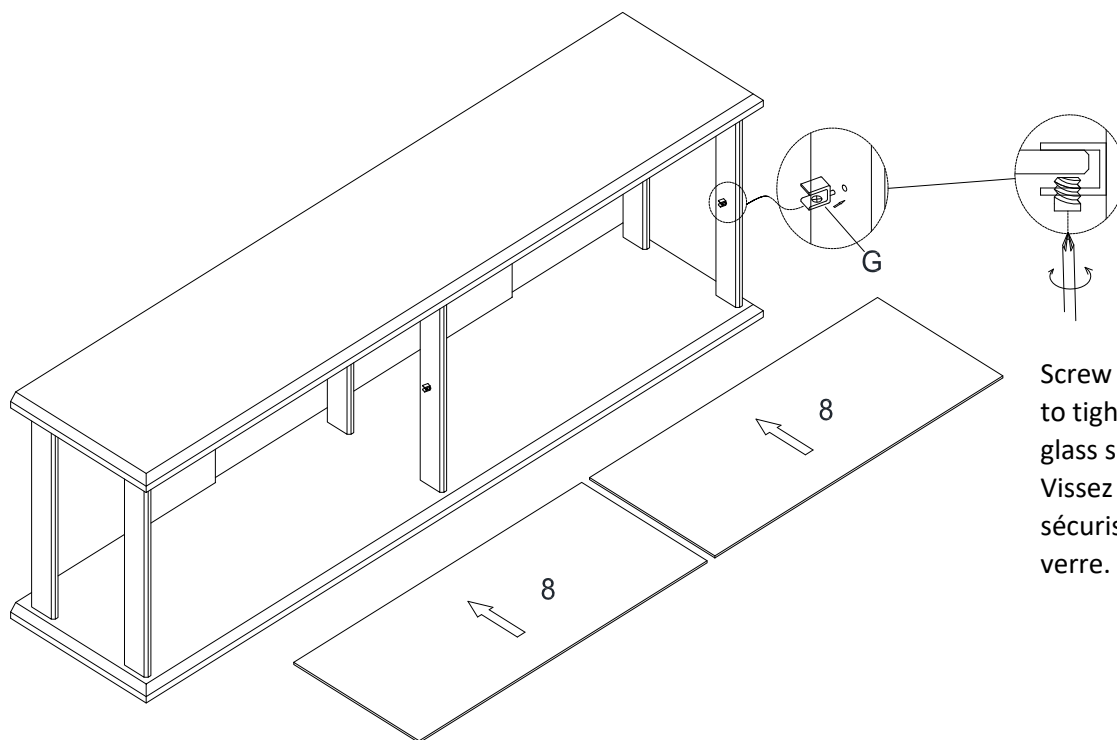

Screw the shelf supports to tighten and secure the glass shelves.
Vissez les supports et sécurisez les tablettes en verre.

Step 7 / Étape 7

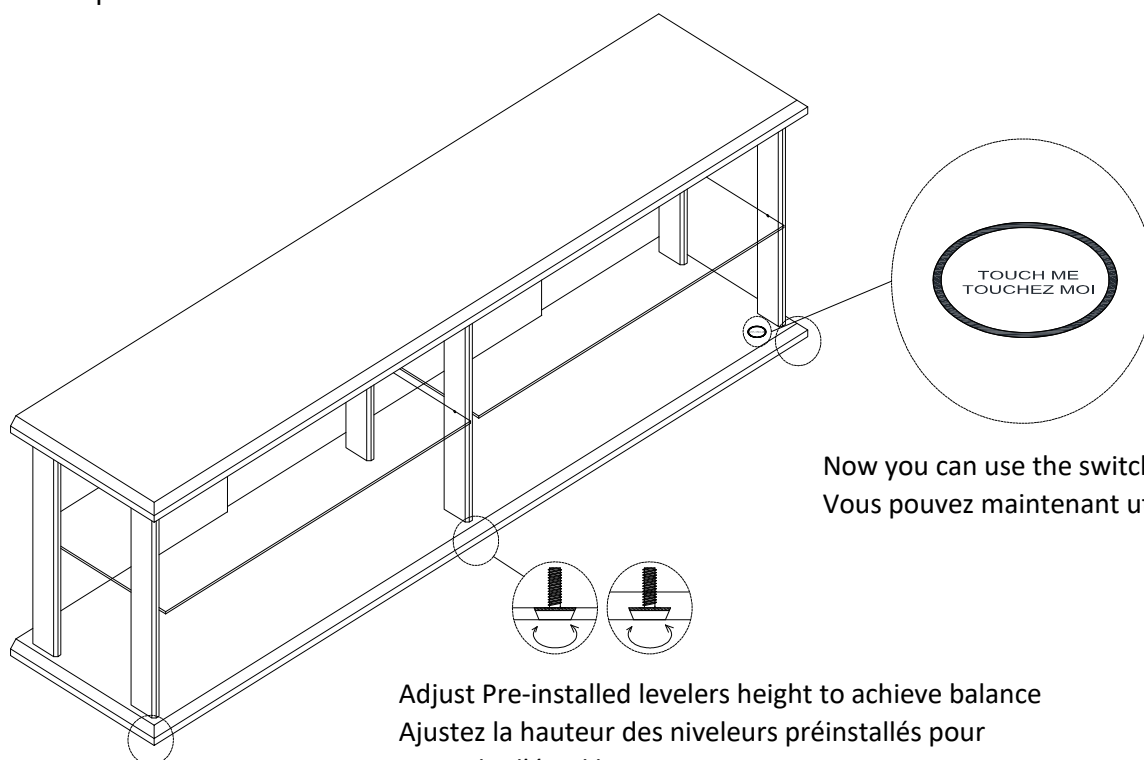

Now you can use the switch.
Vous pouvez maintenant utiliser

Adjust Pre-installed levelers height to achieve balance
Ajustez la hauteur des niveleurs préinstallés pour atteindre l'équilibre