

# ASSEMBLY INSTRUCTIONS / INSTRUCTIONS D'ASSEMBLAGE

---

ITEM NO/NO ARTICLE: 26001

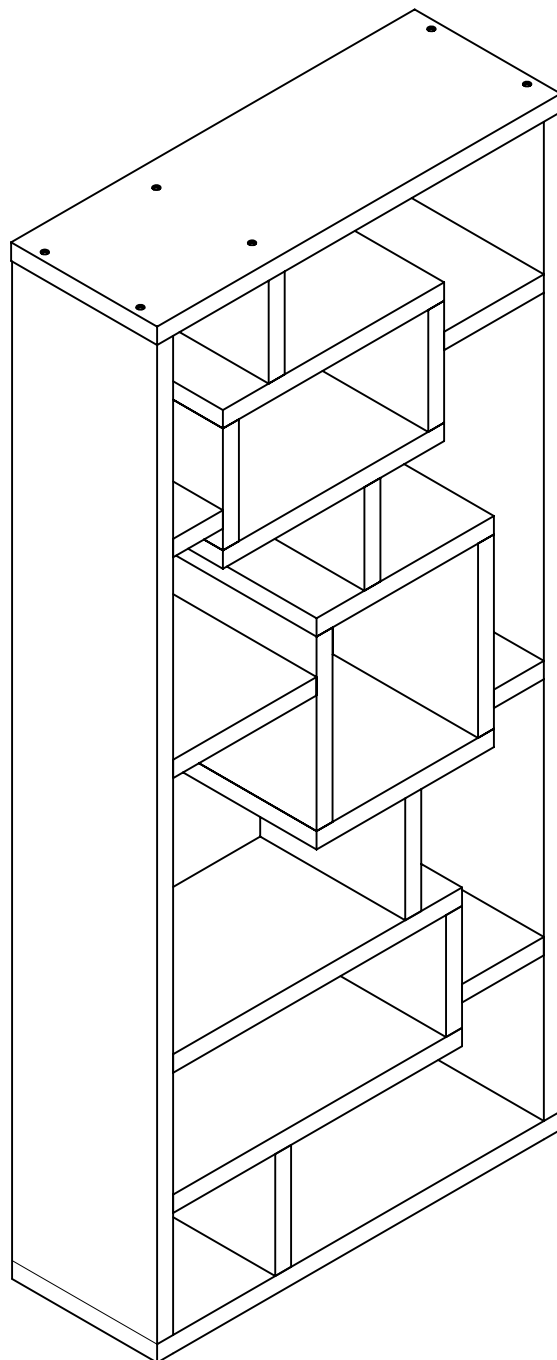

# PARTS IDENTIFICATIONS / IDENTIFICATION DES PIECES



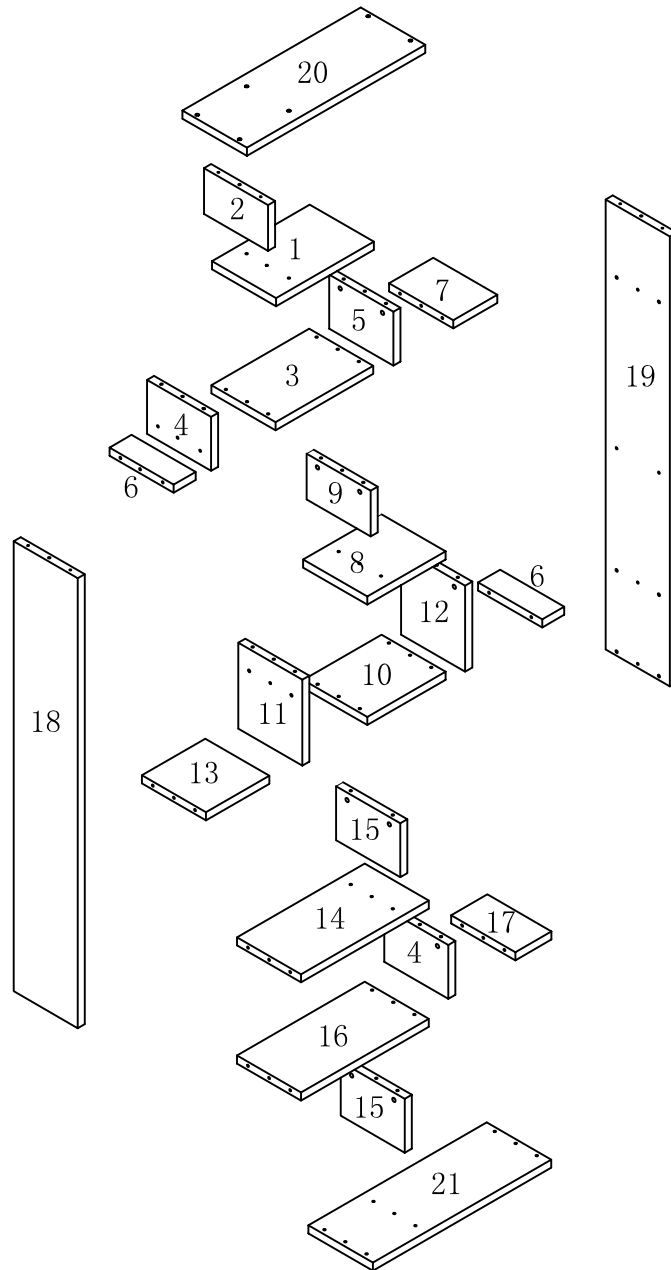

ITEM NO/NO ARTICLE: 26001

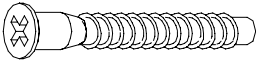
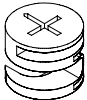
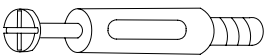
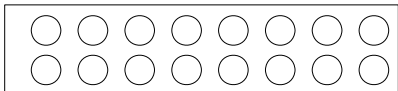
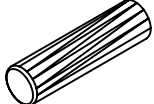

(1) 1pc/pce	(8) 1pc/pce	(15) 2pcs/pces
(2) 1pc/pce	(9) 1pc/pce	(16) 1pc/pce
(3) 1pc/pce	(10) 1pc/pce	(17) 1pc/pce
(4) 2pcs/pces	(11) 1pc/pce	(18) 1pc/pce
(5) 1pc/pce	(12) 1pc/pce	(19) 1pc/pce
(6) 2pcs/pces	(13) 1pc/pce	(20) 1pc/pce
(7) 1pc/pce	(14) 1pc/pce	(21) 1pc/pce

# HARDWARE IDENTIFICATIONS/ IDENTIFICATION DU KIT D'ASSEMBLAGE

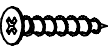
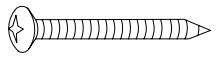
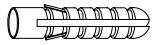
ITEM NO/NO ARTICLE: 26001

A		$\phi 7 \times 58$	28pcs/pces
B		$\phi 15$	40pcs/pces
C		L29	40pcs/pces
D		$\phi 18$	68pcs/pces
E		$\phi 8 \times 25$	34pcs/pces
F			1pc/pce
G		$\phi 4 \times 25$	1pc/pce
H		$\phi 5 \times 40$	1pc/pce
J			1pc/pce
K		Pour coller la rondelle au trou de connexion / To firmly secure the cover to the connecting hole	1pc/pce

STEP 1 / ETAPE 1

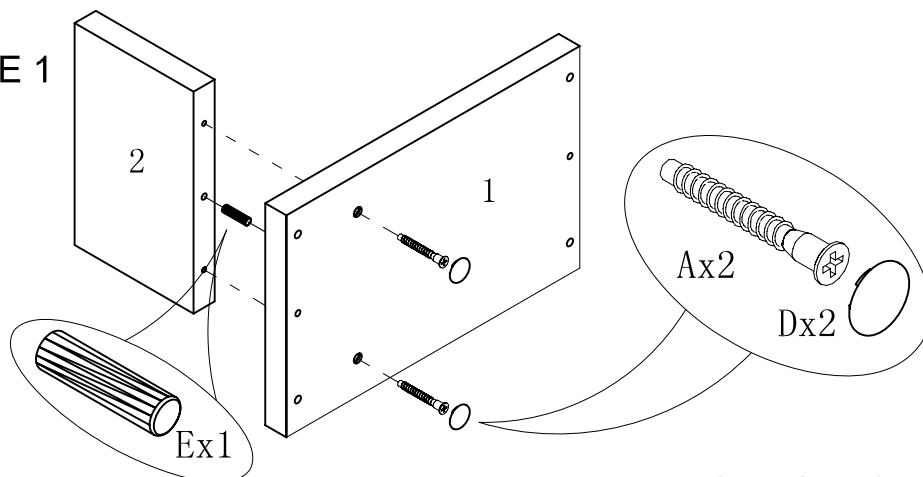

# ITEM NO/NO ARTICLE: 26001

## STEP 2 / ETAPE 2

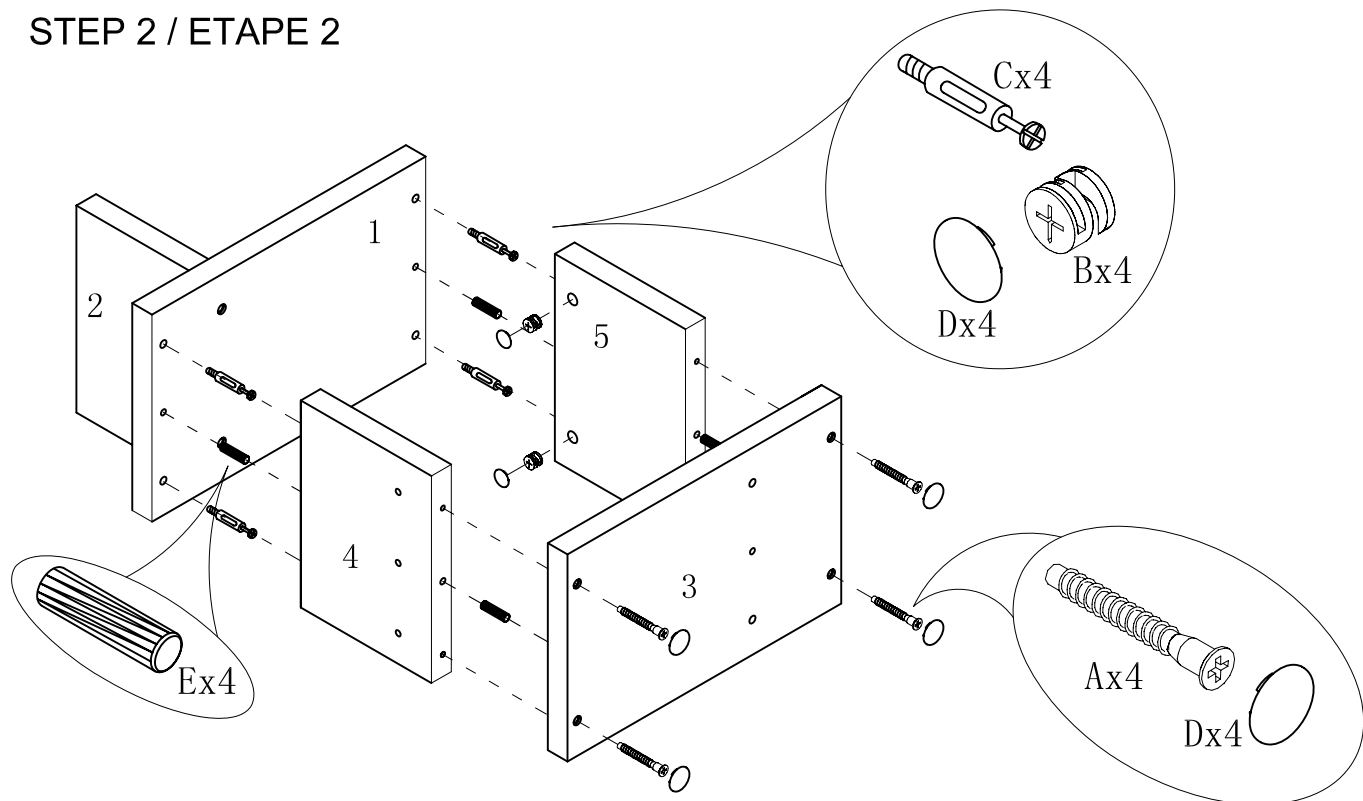

## STEP 3 / ETAPE 3

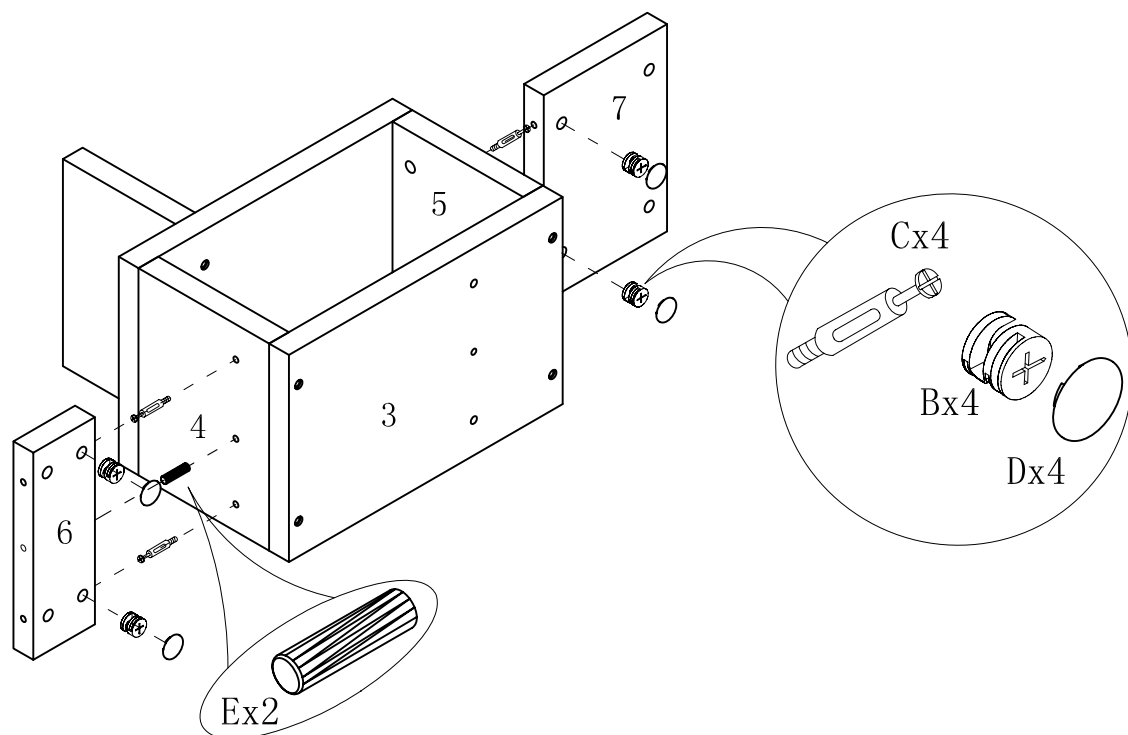

# ITEM NO/NO ARTICLE: 26001

## STEP 4 / ETAPE 4

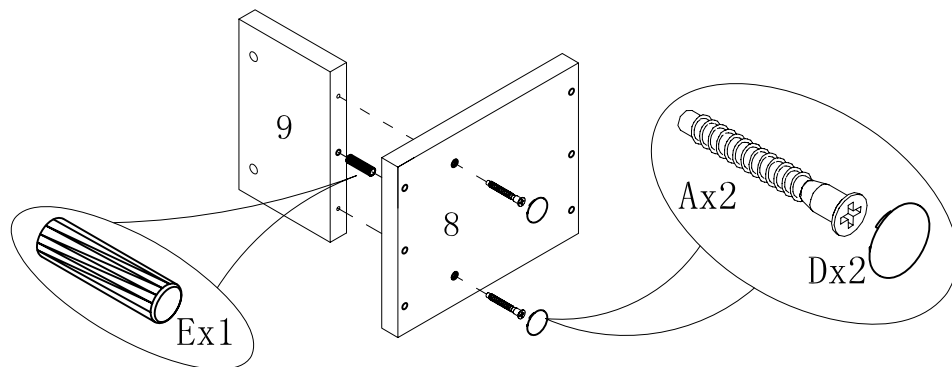

## STEP 5 / ETAPE 5

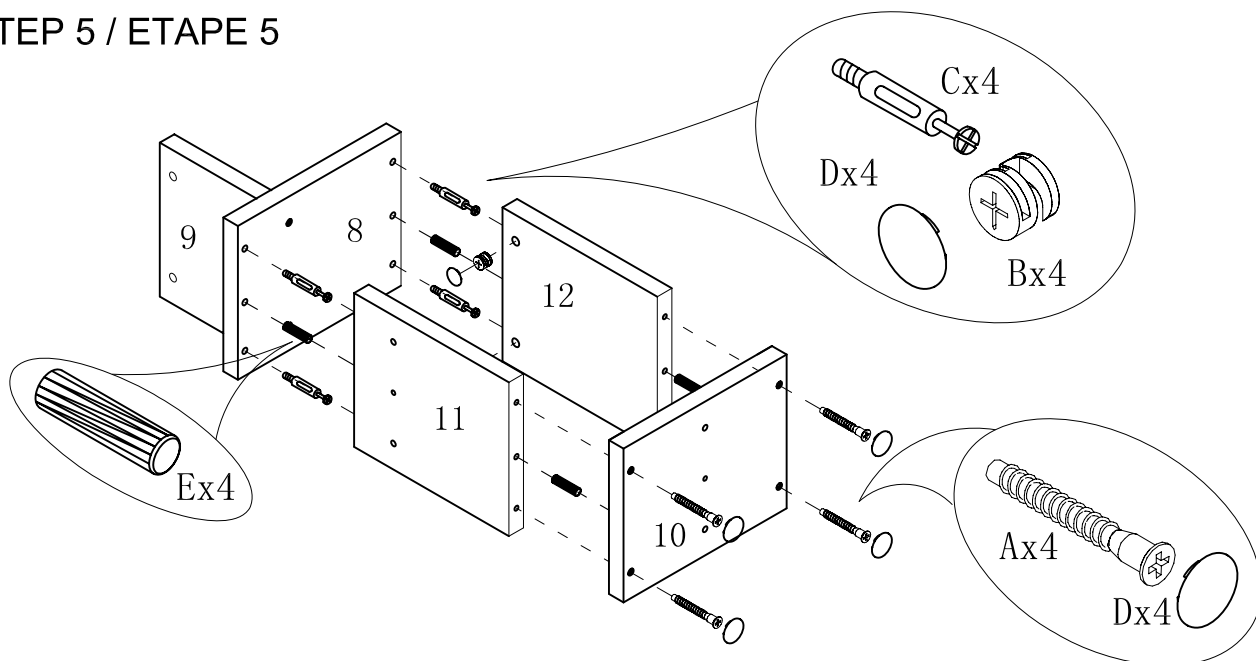

## STEP 6 / ETAPE 6

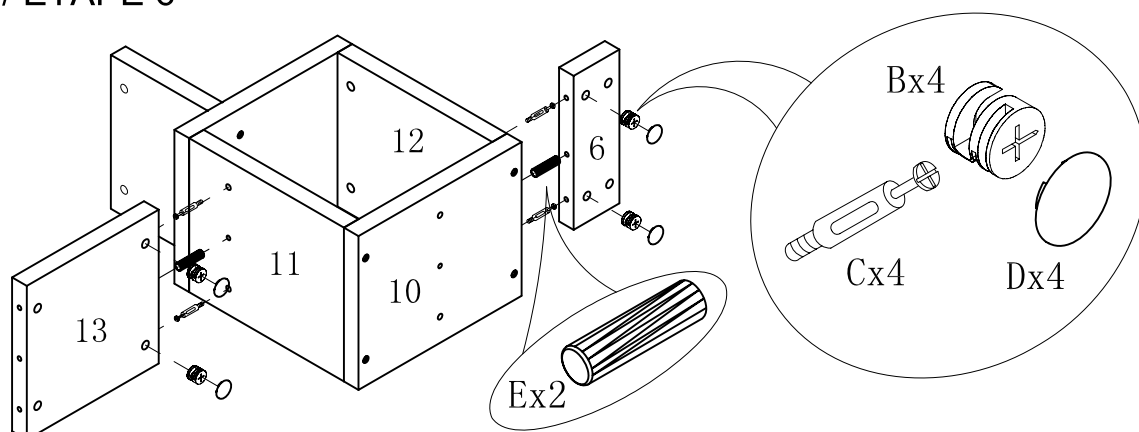

# ITEM NO/NO ARTICLE: 26001

## STEP 7 / ETAPE 7

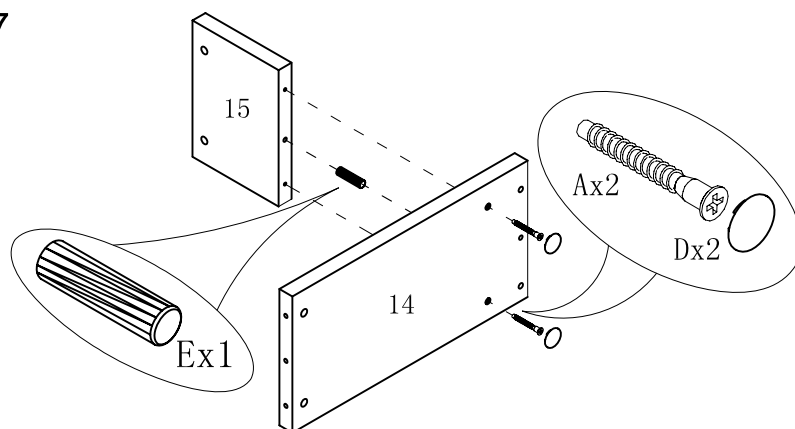

## STEP 8 / ETAPE 8

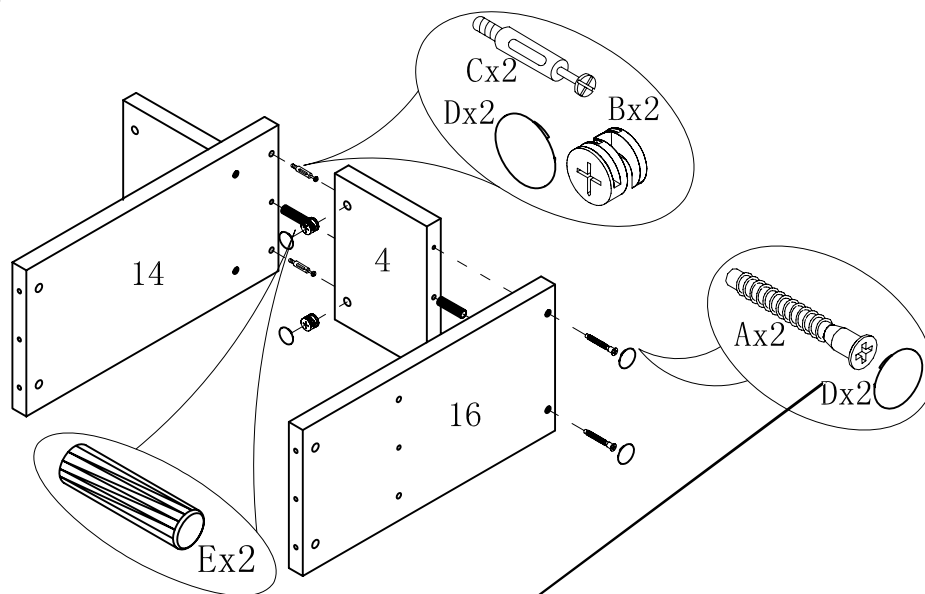

## STEP 9 / ETAPE 9

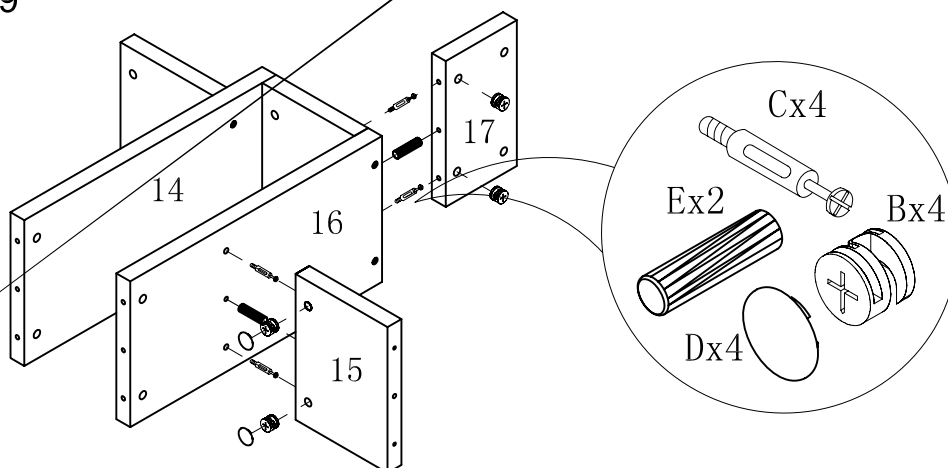

# ITEM NO/NO ARTICLE: 26001

## STEP 10 / ETAPE 10

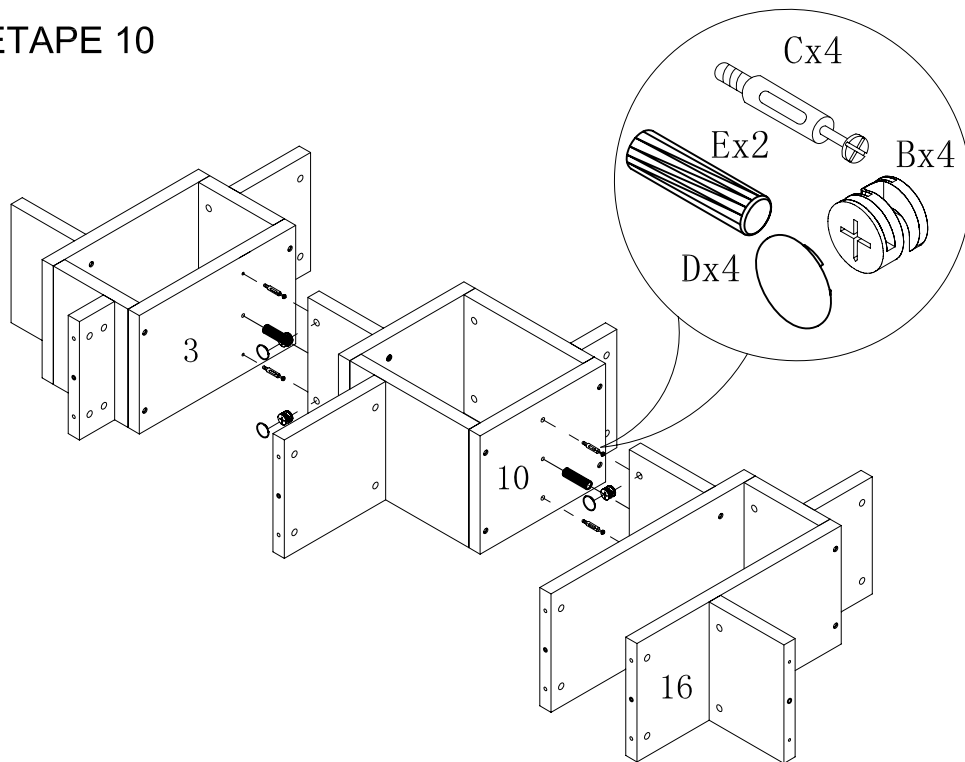

## STEP 11 / ETAPE 11

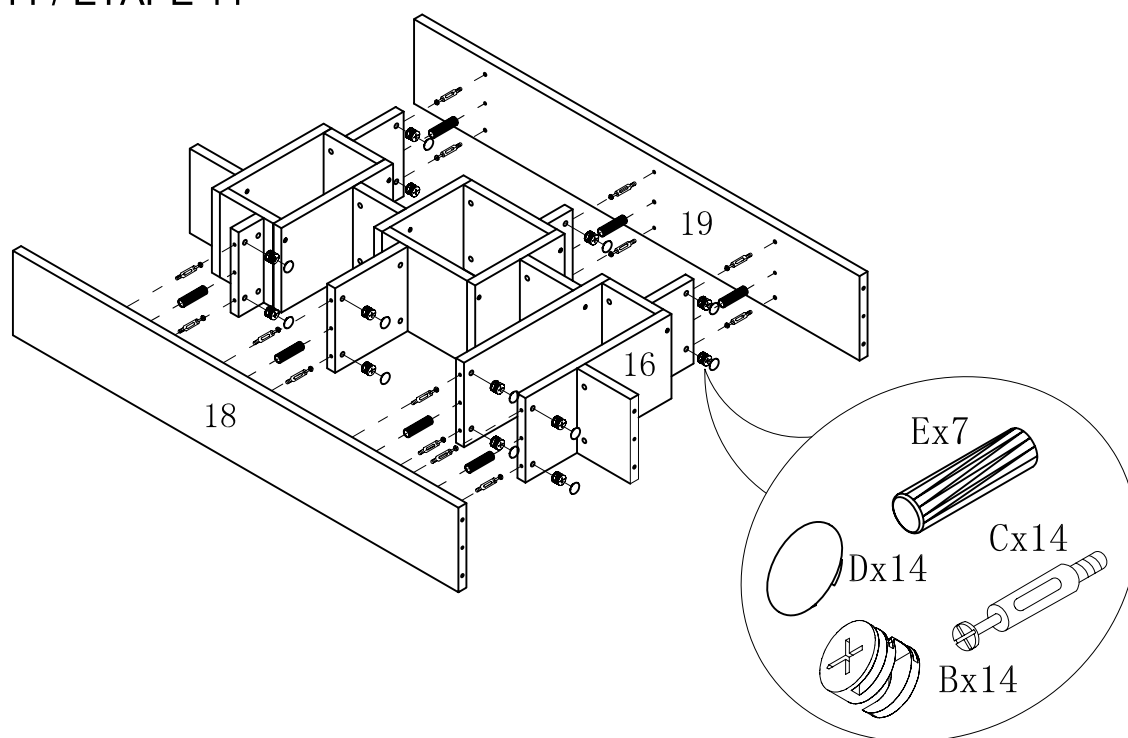

# ITEM NO/NO ARTICLE: 26001

## STEP 12 / ETAPE 12

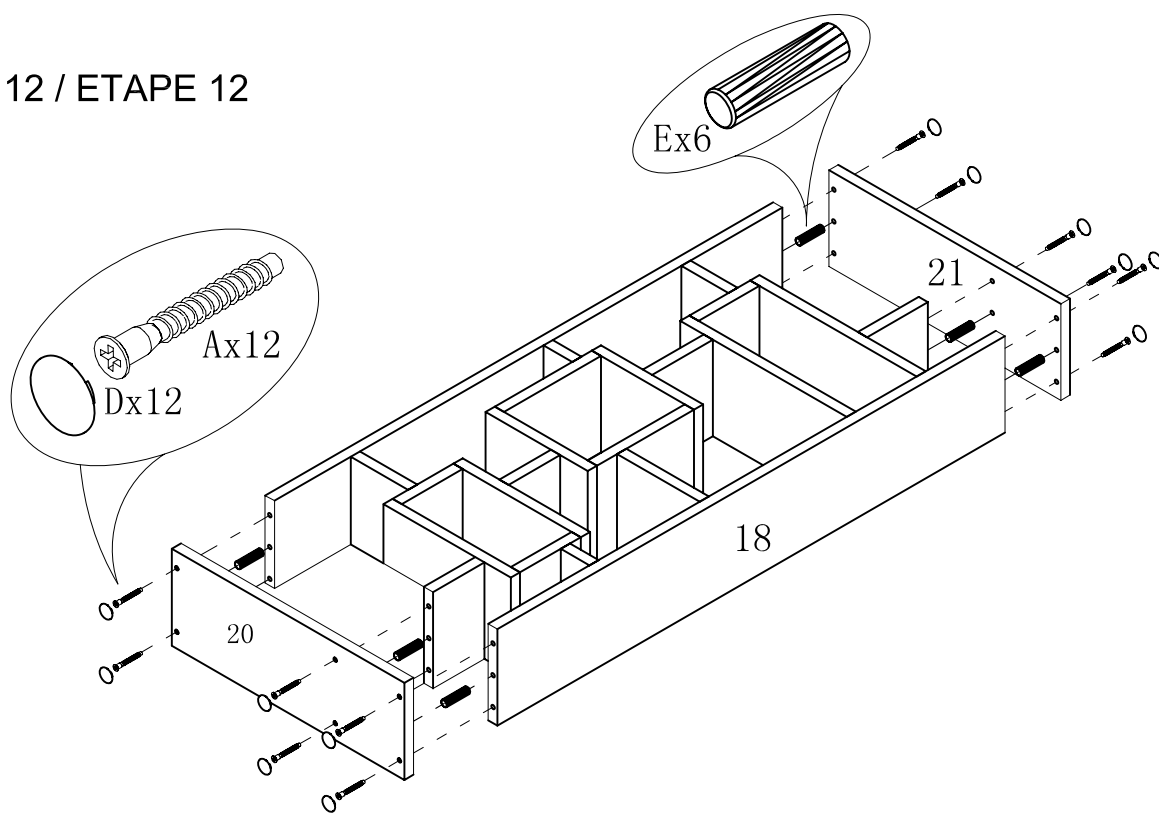

## STEP 13 / ETAPE 13

