

ASSEMBLY INSTRUCTIONS NOTICE D'ASSEMBLAGE

Necessary tools/Outils nécessaires

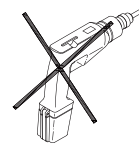
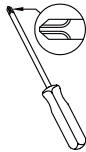
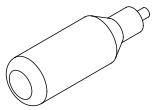

Glue not included (We recommend to apply some glue into holes before inserting wood dowels .)

Colle non inclus (Nous vous recommandons d'appliquer quelques gouttes de colle dans les trous avant d'introduire les chevilles de bois.)

How to use cam lock system/Comment utiliser le système de verrouillage

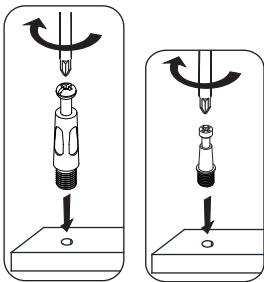

*Screw in cam post and tighten in place.

*Visser le montant de came et serrer en place.

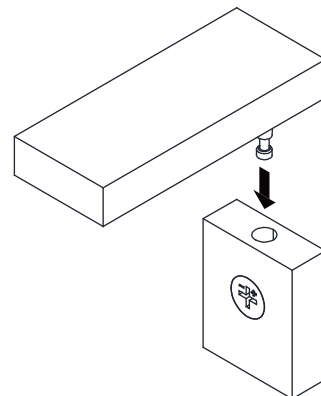
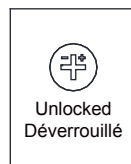
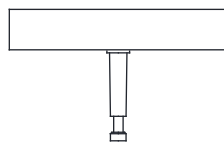

#1
N°1

*Ensure that the cam lock arrow is pointed to the hole, align the cam lock screw to the hole of the cam lock case.

*Assurez-vous que la flèche de verrouillage sur l'écrou de sécurité est orientée vers l'orifice, insérez la vis de verrouillage dans l'orifice.

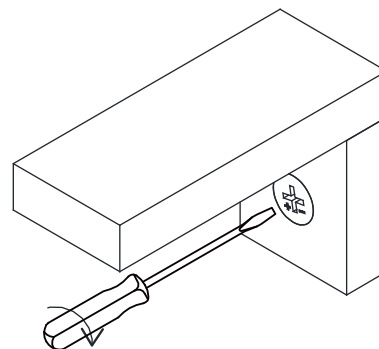
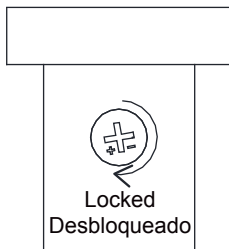

#2
N°2

*Use a straight edge screwdriver to turn cam lock case until it is locked. Locked position is approximately 1/2 turn (210°) clock-wise.

*Utilisez un tournevis ligne droite pour faire tourner l'écrou de sécurité afin de le verrouiller. La position verrouillée est environ 1/2 tour (210°) à la droite.

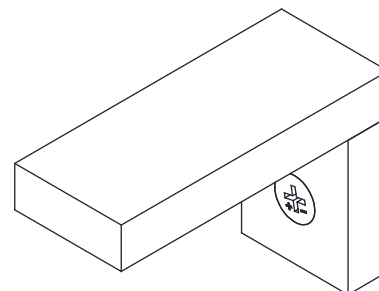
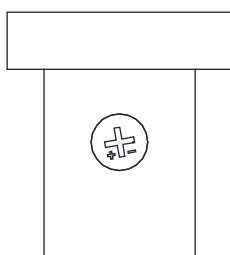

#3
N°3

*After turning the cam lock case to the locked position, the cam lock arrow will be located in the position shown above.

*Après avoir tourné l'écrou de sécurité pour le verrouiller, la flèche de serrure de came se situeront dans la position indiquée ci-dessus.

ASSEMBLY INSTRUCTIONS / INSTRUCTIONS D'ASSEMBLAGE

ITEM NO/NO ARTICLE: HARVWSTB/233201

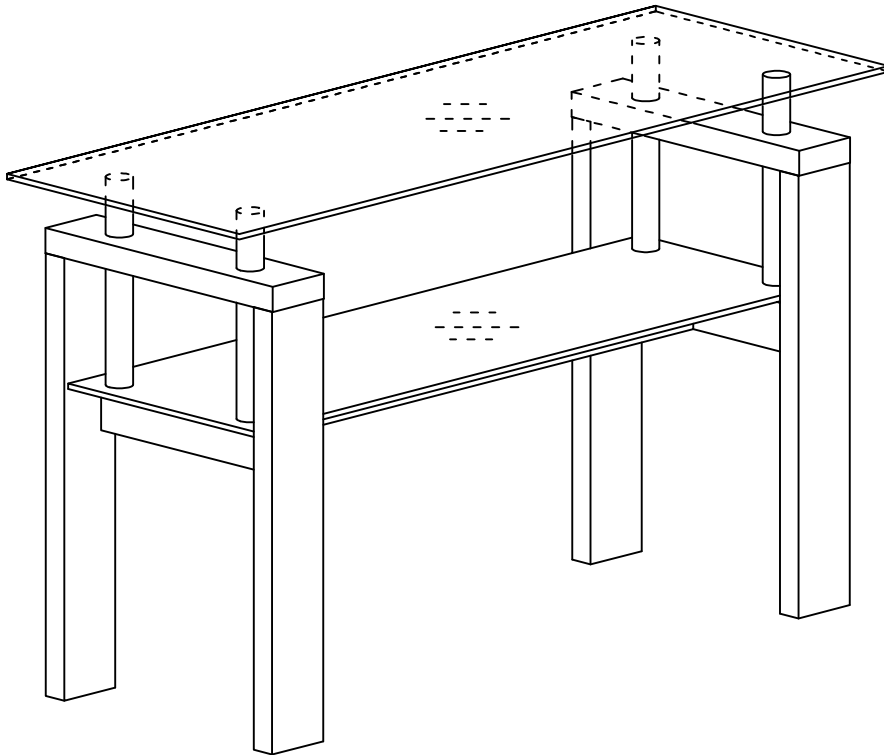

PARTS IDENTIFICATIONS / IDENTIFICATION DES PIECES



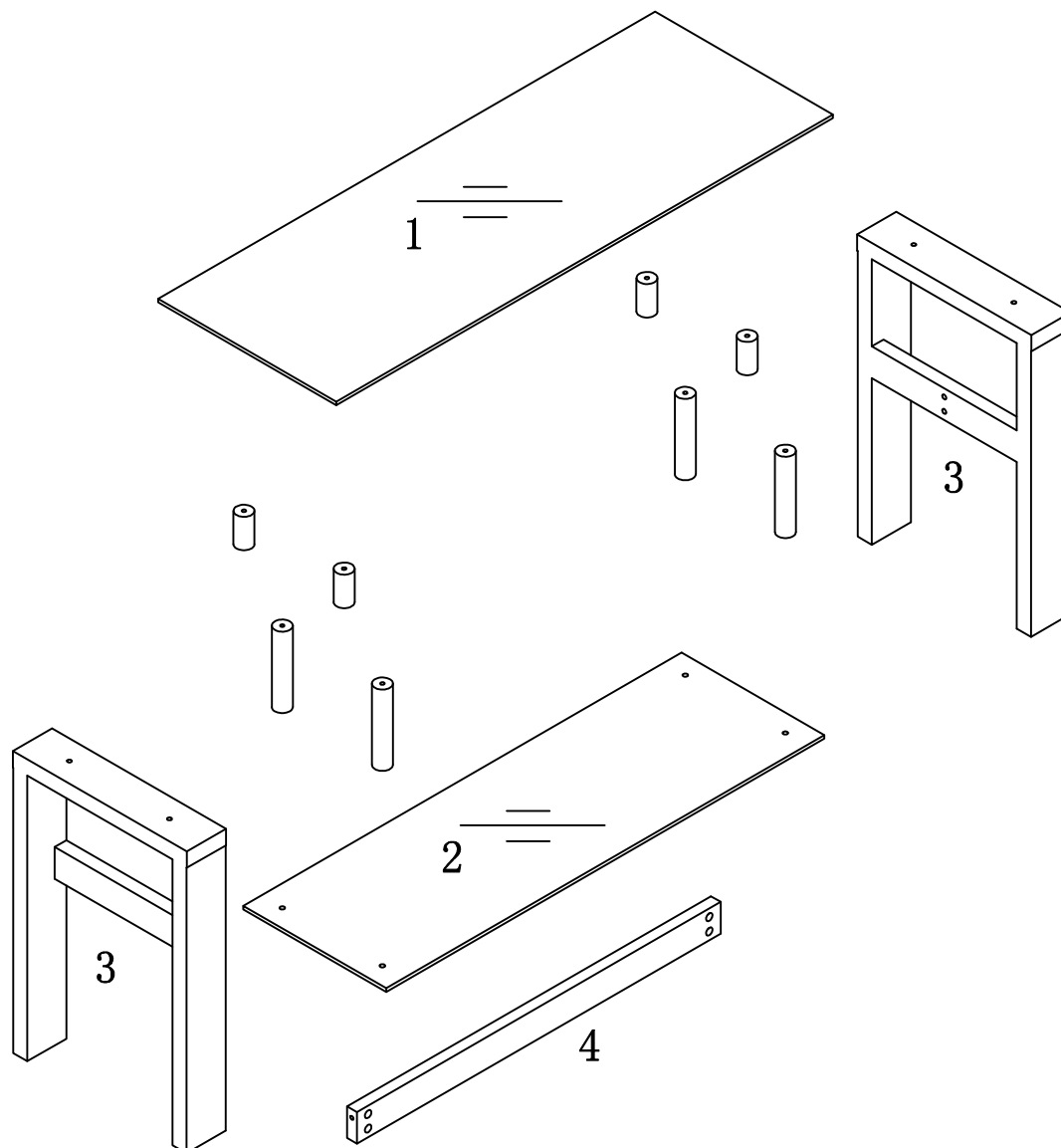











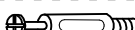

ITEM NO/NO ARTICLE: HARVWSTB/233201



- (1) 1pc/pce
- (2) 1pc/pce
- (3) 2pcs/pces
- (4) 1pc/pce

HARDWARE IDENTIFICATIONS/ IDENTIFICATION DU KIT D'ASSEMBLAGE

ITEM NO/NO ARTICLE: HARVWSTB/233201

| | | | |
|---|---|----------------------------------|----------|
| A |  | $\phi 8 \times 25$ | 4pcs/pcs |
| B |  | $\phi 8 \times 65$ | 4pcs/pcs |
| C |  | M8 x 20 | 4pcs/pcs |
| D |  | $\phi 8 \times \phi 16 \times 2$ | 4pcs/pcs |
| E |  | M5 | 1pc/pce |
| F |  | $\phi 16$ | 4pcs/pcs |
| G |  | L29 | 4pcs/pcs |
| H |  | $\phi 15$ | 4pcs/pcs |
| I |  | $\phi 22$ | 4pcs/pcs |
| J |  | 197x5x1 | 1pc/pce |
| K |  | $\Phi 8 \times 40$ | 1pc/pce |
| L |  | 12x12x1 | 2pcs/pcs |
| M |  | $\Phi 5 \times 40$ | 1pc/pce |
| N |  | $\Phi 4 \times 25$ | 1pc/pce |
| O |  | $\Phi 38 \times 74$ | 4pcs/pcs |
| P |  | $\Phi 38 \times 180$ | 4pcs/pcs |
| Q |  | $\phi 18$ | 4pcs/pcs |

ITEM NO/NO ARTICLE: HARVWSTB/233201

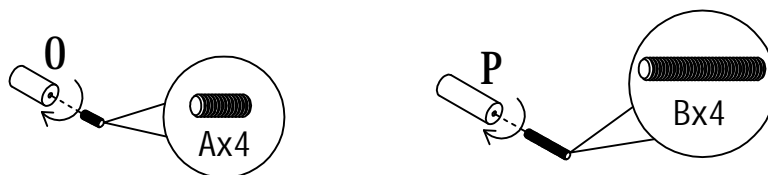

STEP 1 / ETAPE 1

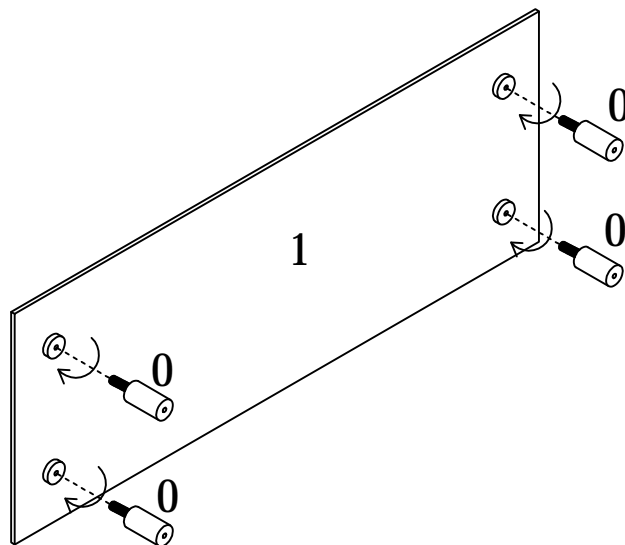

STEP 2 / ETAPE 2

STEP 3 / ETAPE 3

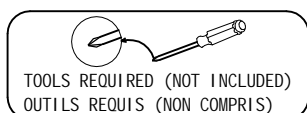
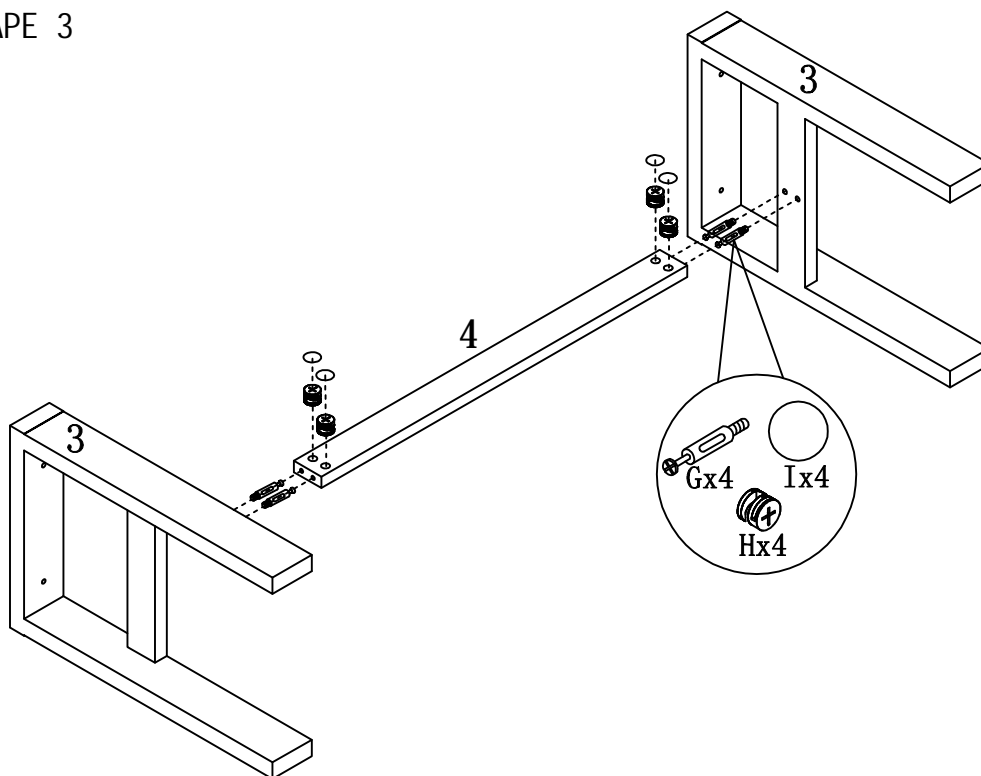

ITEM NO/NO ARTICLE: HARVWSTB/233201

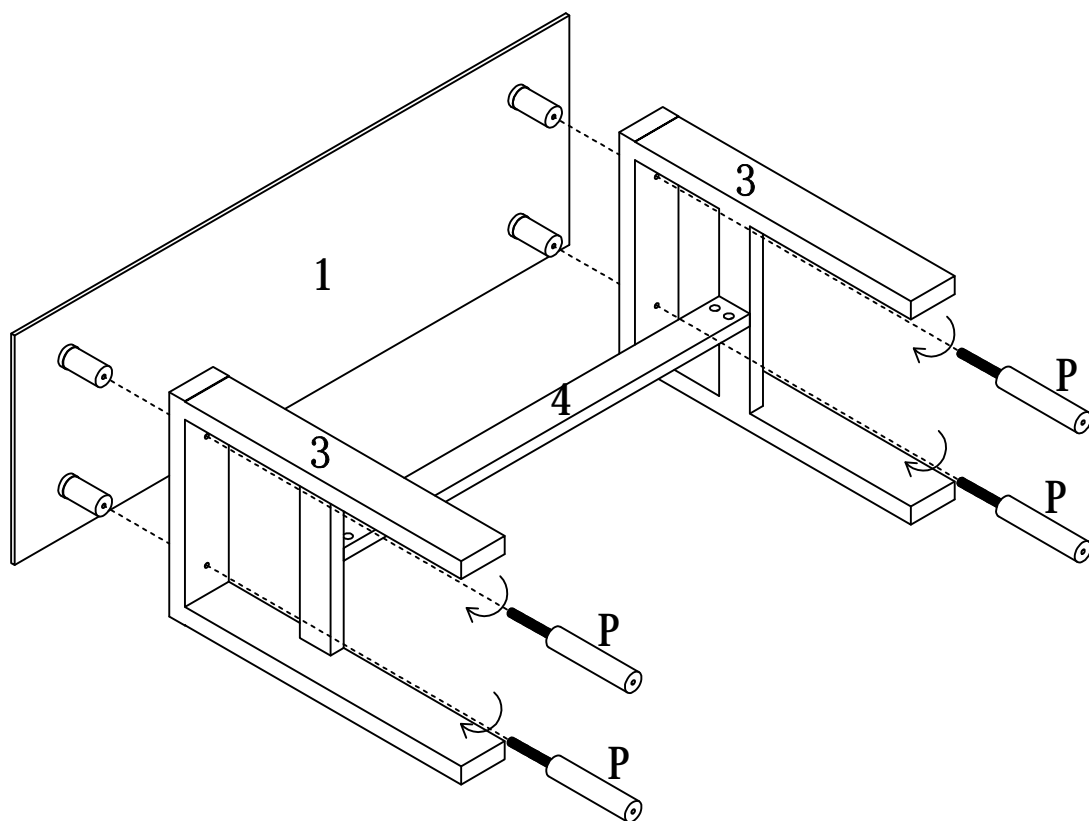

STEP 4 / ETAPE 4

STEP 5 / ETAPE 5

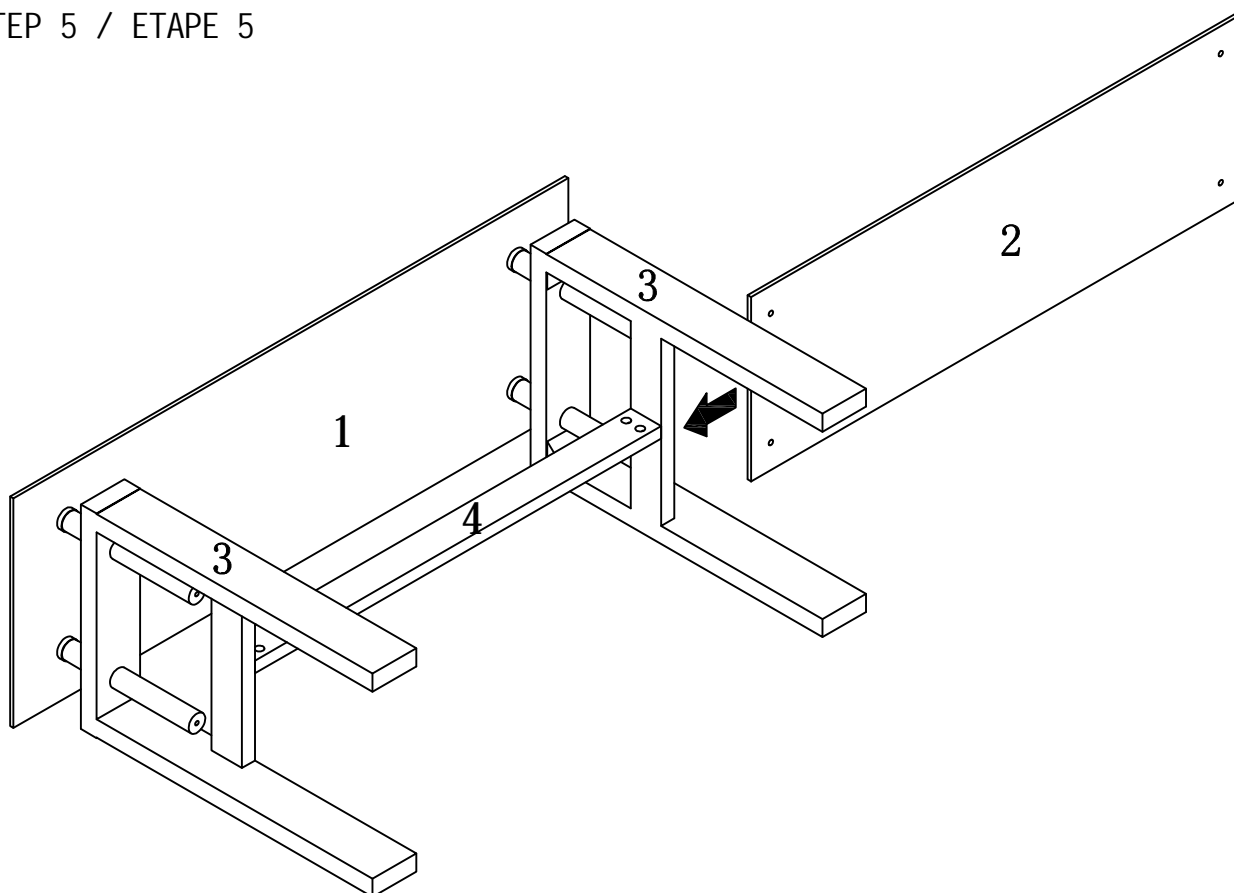

PAGE 5 OF 6 / PAGE 5 DE 6

ITEM NO/NO ARTICLE: HARVWSTB/233201

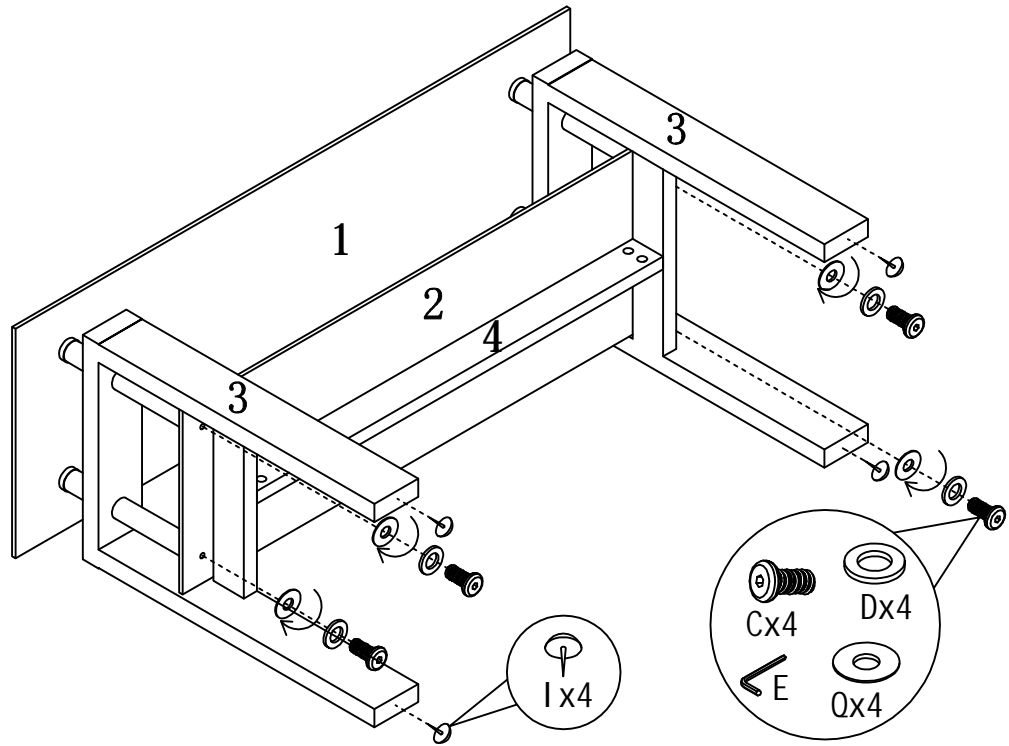

STEP 6 / ETAPE 6

STEP 7 / ETAPE 7

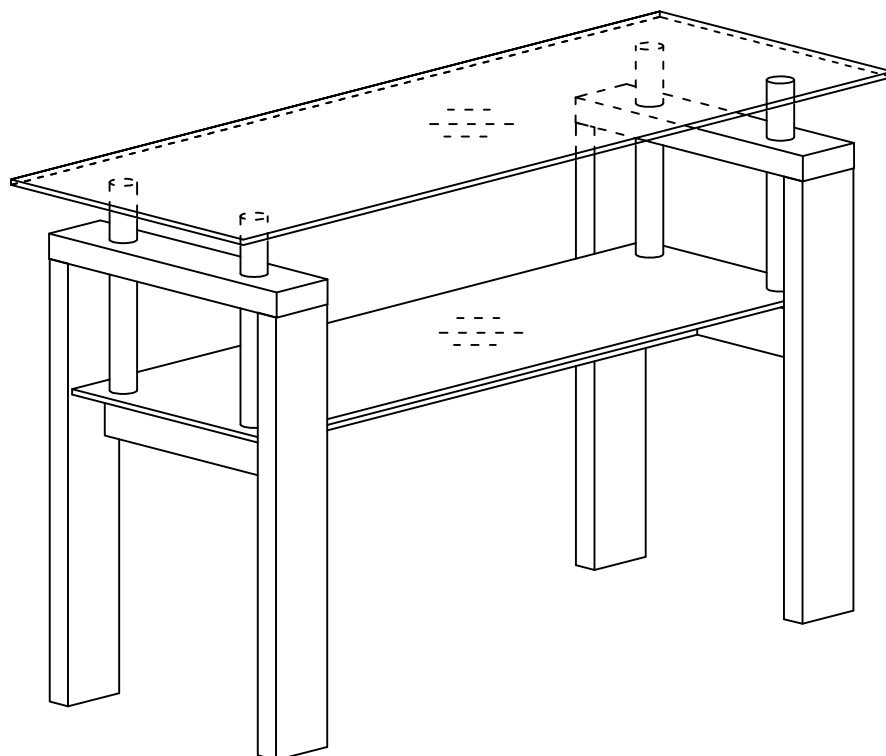

ANTI-TIPPING STRAP INSTRUCTION

Instructions pour sangle anti-basculement

Quincaillerie (Incluse):

 DRYWALL ANCHOR $\phi 8 \times 40$ X 1PCS

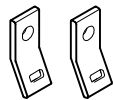

Fixation en métal $12 \times 12 \times 1$ X 2PCS

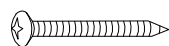

Vis $\phi 5 \times 40$ X 1PCS



Sangle $197 \times 5 \times 1$ X 1PCS



Vis $\phi 4 \times 25$ X 1PCS

Outils requis (Non inclus):

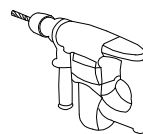

DRILL & DRILL BIT
Perceuse et trépan



LIGHT HAMMER
Marteau léger

Note: Hardware included only compatible with standard drywalls. :Notez que la quincaillerie incluse est compatible avec les ancrages de mur standard

Step 1 Étape 1

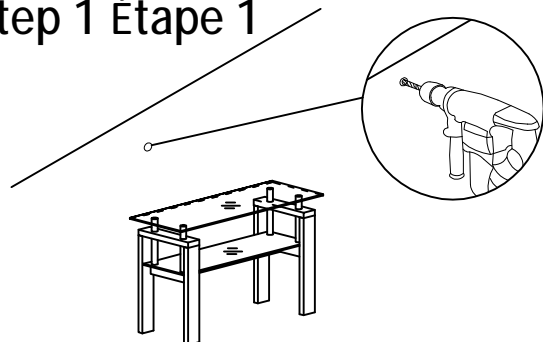

1. Find spot on wall 1" below the top of item.
Placer sur le mur à 1 pouce au-dessus de l'article.
2. Using a drill bit slightly smaller than the gauge of anchor, drill a hole, then place the anchor into wall.
À l'aide d'un trépan légèrement plus petit qu'un ancrage en acier de jauge, percer un trou puis placer l'ancrage dans le mur.

Step 2 Étape 2

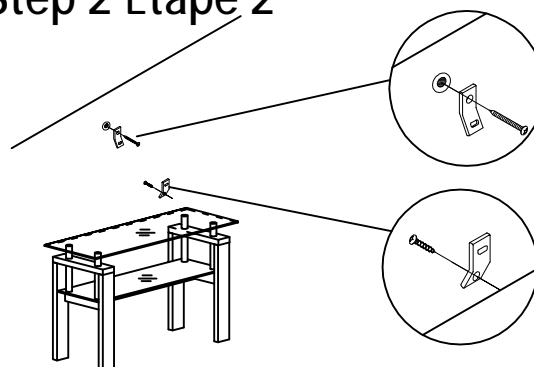

1. Screw the metal bracket into the anchor of wall.
Visser la première fixation en métal à l'intérieur de l'ancrage de mur.
2. Screw the second metal bracket into the back of item along the of soleid frame.
Visser la deuxième fixation à l'arrière de l'article.

Step 3 Étape 3

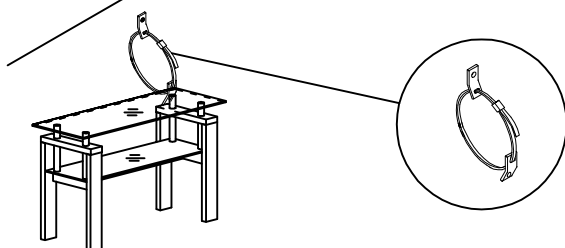

1. Insert strap thru the bracket attached to wall and the second attached to the product.
Insérer la sangle à l'intérieur de la fixation en métal. Elle s'attache facilement sur l'arrière du meuble, l'autre bout étant fixé au mur.
2. Pull tightly: Et puis tirer fermement.