













ASSEMBLY INSTRUCTIONS

**MODEL : C8331L
QUEEN&FULL BED (4+4)**

(Box 1)
BOX OF HEADBOARD & FOOTBOARD

No	ITEM	Qty
A	Headboard 	1 pc
B	Footboard 	1 pc
C	Headboard Leg 	2 pcs
D	Bed Slats 	4 pcs
E	Bed Slats Support 	4 pcs
F	Side Rail 	2 pcs

(Box 1)
HARDWARE LIST(HARDWARE INSIDE HB & FB BOX)

No	ITEM	Qty
1	JCBC M6 x 35mm 	4 pcs
2	SPRING WASHER 1/4" Rbw 	4 pcs
3	Flat Washer 1/4"ID x 13mmOD Blk 	4 pcs
4	ALLEN KEY m4x65mm Blk 	1 pc
5	ALLEN KEY m5x65mm Blk 	1 pc
6	Flat Head Chipboard Screw m4x32mm Rbw 	16 pcs

STEP 1.1 Attach Head Board Leg (C) to Head Board (A) as shown using JCBC BOLT(1)with Spring Washer (2), Flat washer (3)and securing with ALLEN KEY (4) .

STEP 1.2 : Fix the other holes with Csk Screw (6) as shown.

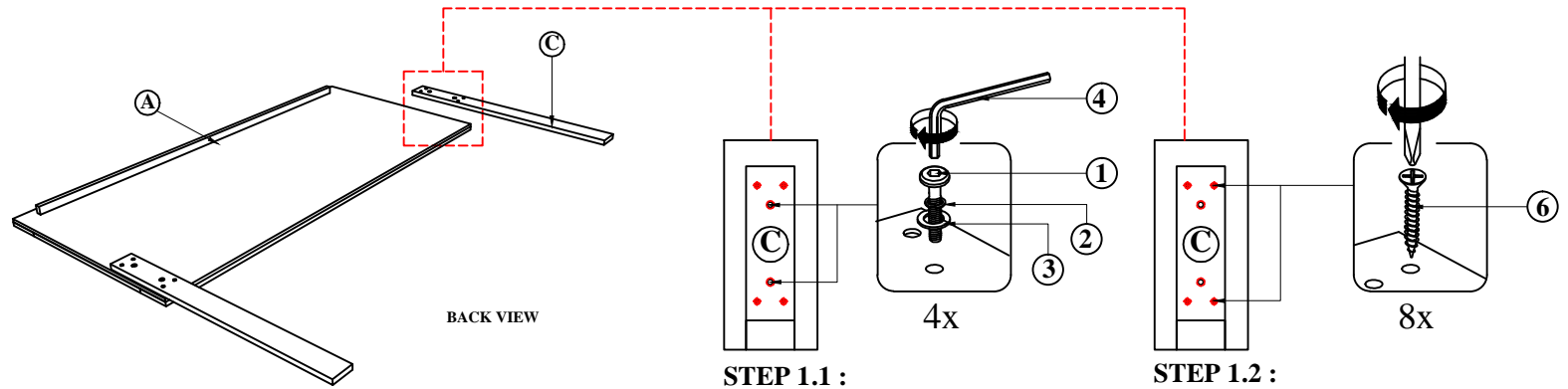

STEP 2 : Hook SIDE RAIL(F) TO HEAD BOARD (A) closely and push down to fit. repeat step 2 with other end of rail to hook onto FOOTBOARD (B).

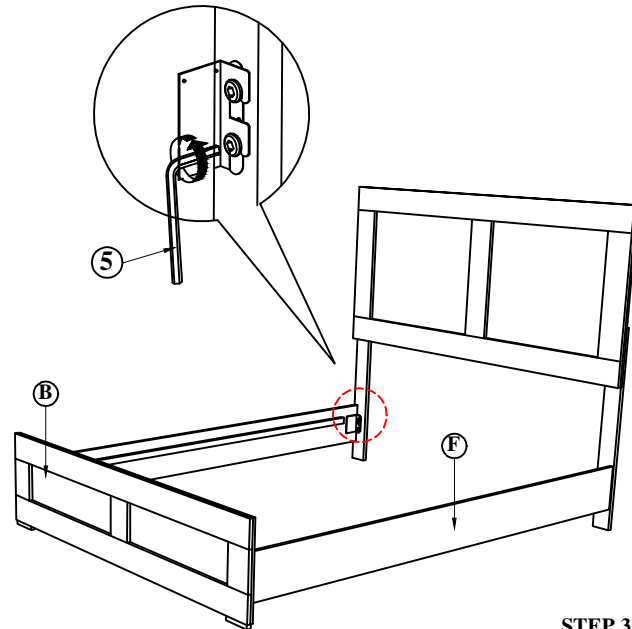

STEP 3 : Tighten the 4 Corner with Allen Key (5).Fix the Bed Slat Support Leg (E) , to Bed Slat (D) as shown . Install the bed slat (D) to side rail (F) and tighten with Csk Screw (6) as per diagram shown. (NOTE: THE SETUP MUST DONE AT THE DECIDED LOCATION FOR THE BED TO OBTAIN PERFECT STABILITY)

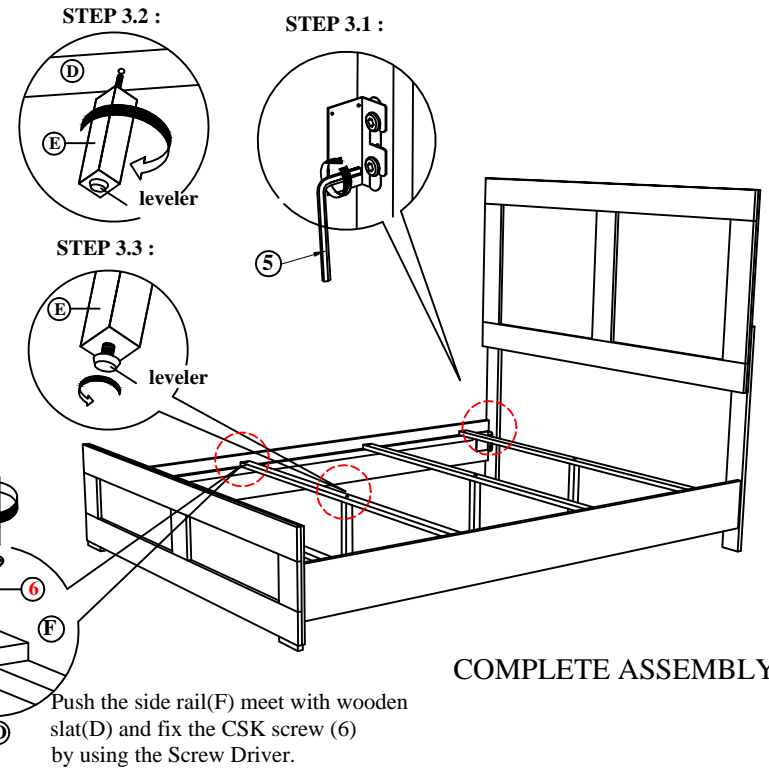

COMPLETE ASSEMBLY