







ASSEMBLY INSTRUCTIONS (INSTRUCTIONS D'ASSEMBLAGE)

2367

HARDWARE LIST (LISTE DES OUTILS):

NO. NO.	Sketch Schéma	Description Description	Qty Qté
A		Bolt(1/4"*1-5/8") Boulon	6 PCS 6 PCES
B		Spring Washer 1/4" Rondelle frein	6 PCS 6 PCES
C		Flat Washer 1/4" Rondelle plate	6 PCS 6 PCES
D		Allen Key(4mm) Clé hexagonale	1 PC 1 PCE

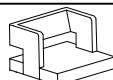
PARTS LIST (LISTE DES PIECES):

NO. NO.	Sketch Schéma	Description Description	Qty Qté
1		Seat Siège	1 PC 1 PCE
2		Left Leg Jambe Gauche	1 PC 1 PCE
3		Right Leg Jambe Droite	1 PC 1 PCE

Step 1

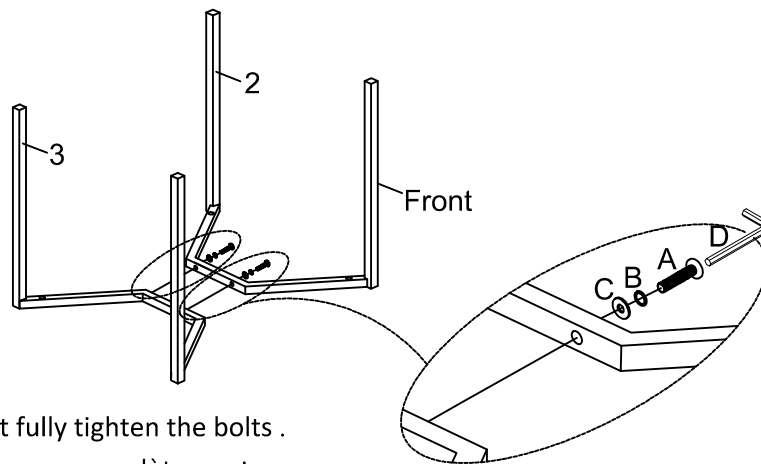

Note: At this stage, do not fully tighten the bolts .
À noter qu'il ne faut pas serrer complètement les boulons à ce stade.

Step 2

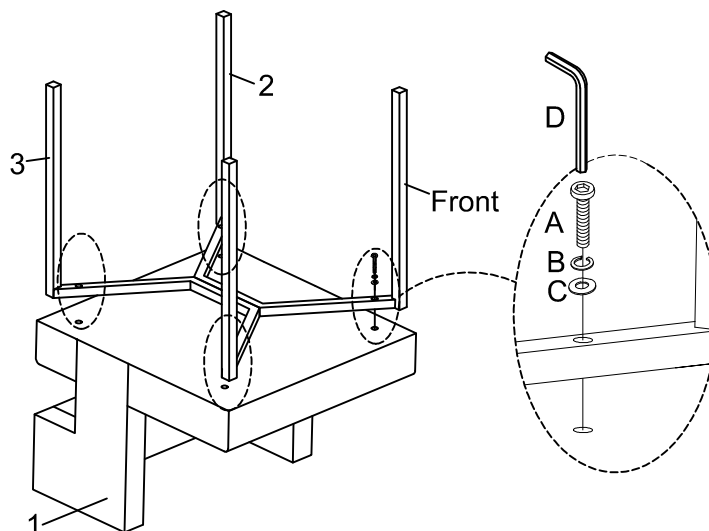

Step 3

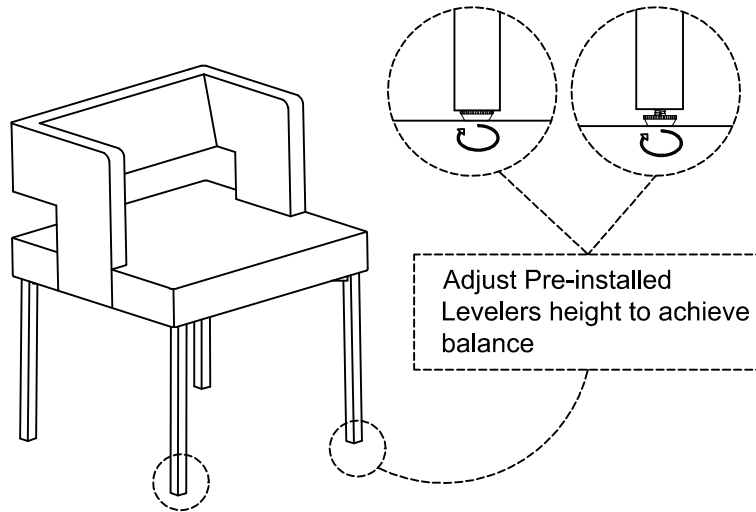

Step 4

