







ASSEMBLY INSTRUCTIONS

MODEL : SB252A
QUEEN & FULL (4+4)



(Box 1)
BOX OF HEADBOARD & FOOTBOARD

No	ITEM	Qty
A	Headboard 	1 pc
B	Footboard 	1 pc
C	Headboard Leg(L&R) 	2 pcs
D	Bed Slats 	4 pcs
E	Bed Slats Support 	4 pcs

(Box 2)
BOX OF SIDE RAIL

No	ITEM	Qty
F	Side Rail 	2 pcs

(Box 1)
HARDWARE LIST(HARDWARE INSIDE HB & FB BOX)

No	ITEM	Qty
1	ALLEN KEY m5x65mm Blk 	1 pc
2	Flat Head Chipboard Screw m4x32mm Rbw 	16 pcs
3	Adaptor 5V1A UL Certificate 	1 pc

STEP 1.1 : Align Head Board Leg (C) to Head Board (A) by attach them to the marking stopper as shown .

STEP 1.2 : Attach Head Board Leg (C) to Head Board (A) as shown using Csk Screw (2) and securing with Screw driver(NOT PROVIDED) .

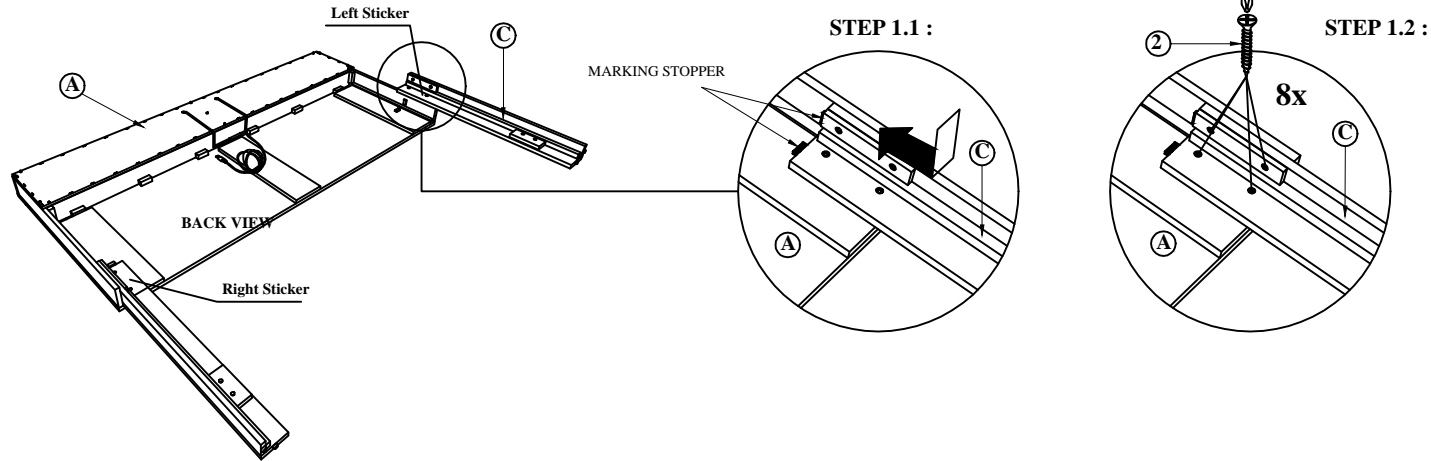

STEP 2 : Tighten the 4 Corner with Allen Key (1) .

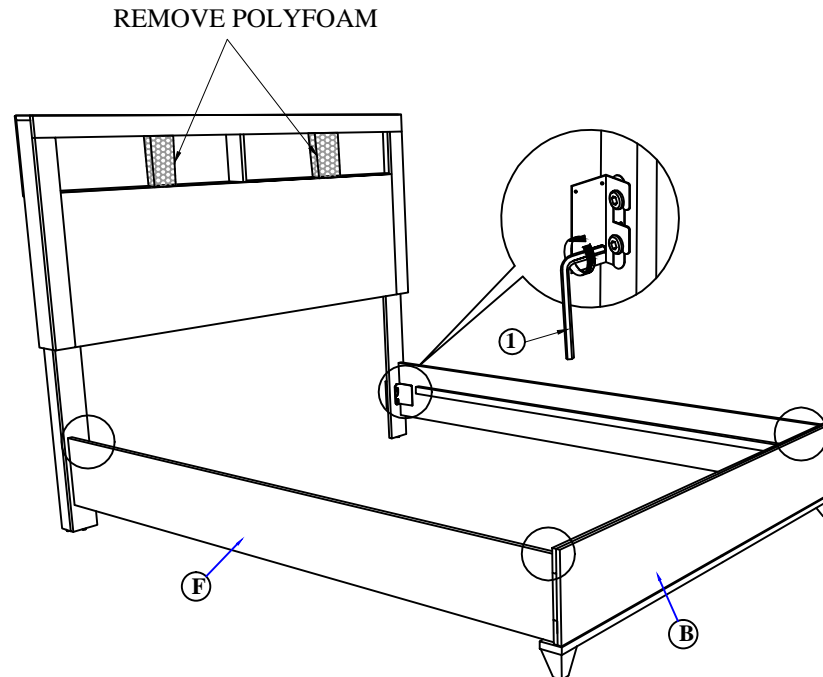

NOTE : MUST TIGHTEN SCREWS PERIODCALLY WITH USE SCREW WILL BECOME LOOSE CHECK TIGHTNESS OF ALL SCREW EVERY 6-8 WEEKS.

ASSEMBLY INSTRUCTIONS

STEP 3 : Fix the Bed Slat Support Leg (E), to Bed Slat (D) as shown . Install the bed slat (D) to side rail (F) and tighten with Csk Screw (2) as per diagram shown. (NOTE: THE SETUP MUST DONE AT THE DECIDED LOCATION FOR THE BED TO OBTAIN PERFECT STABILITY)

STEP 3.3 :

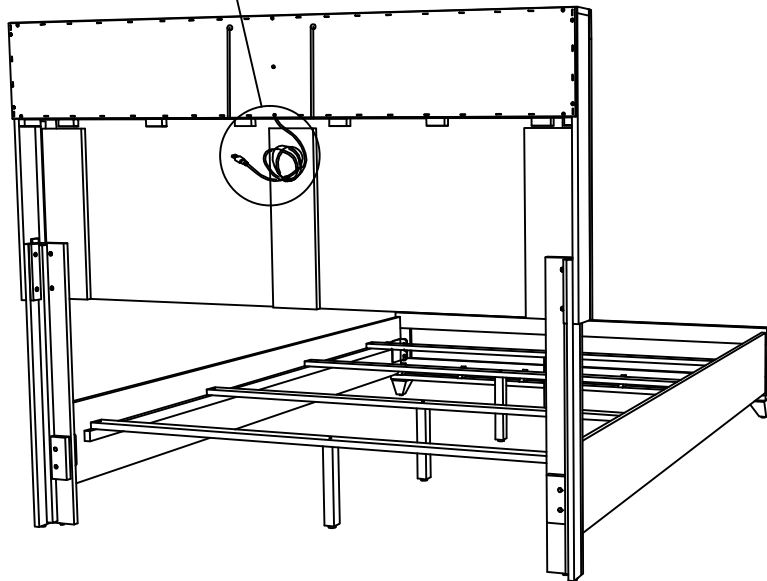
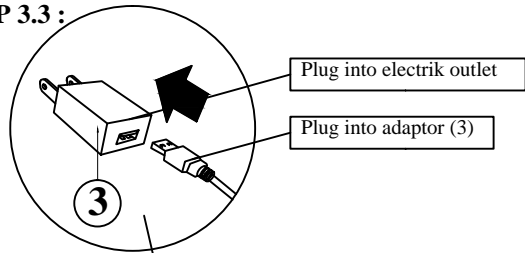

STEP 3.1 :

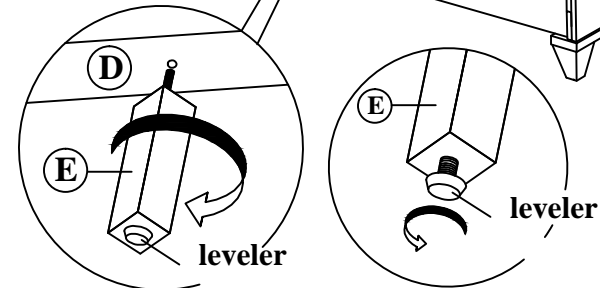

ON & OFF
Touch
Sensor

STEP 3.2 :

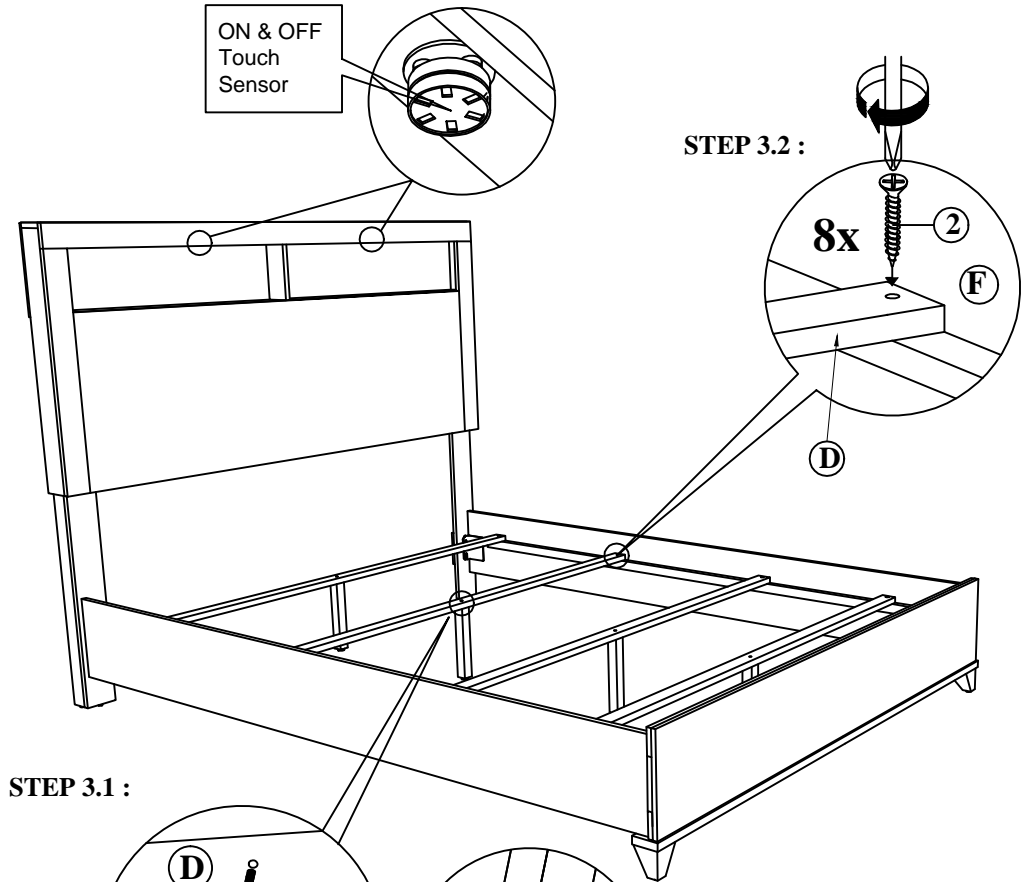





COMPLETE ASSEMBLY

INSTRUCTIONS D'ASSEMBLAGE

MODÈLE: SB252A
GRAND & COMPLET LIT (4 + 4)

(Boîte 1)

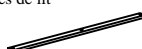
Tête et pied de lit

No.	Article	Quantité
A	Tête de lit 	1 pce
B	Pied de lit 	1 pce
C	Pied de la tête de lit 	2 pces
D	Lattes de lit 	4 pces
E	Support pour lattes 	4 pces

Boite 2



Rails latéraux

No.	Article	Qté
F	Rails latéraux 	2 pces

(Boîte 1)

Liste du matériel

(Matériel à l'intérieur de la boîte de tête et pieds)

No.	Liste du matériel	Quantité
1	CLÉ Allen M5 x 65mm 	1 pce
2	Vis à tête plate pour panneau de particules m4 x 32mm Rbw 	16 pces
3	Adaptateur 5V1A UL Certifié 	1 pce

ÉTAPE 1.1: Alignez le pied de la tête de lit (C) sur la tête de lit (A) en les attachant au butoir, comme illustré.

ÉTAPE 1.2: Fixez le pied de la tête de lit (C) à la tête de lit (A) comme indiqué à l'aide de la vis à tête cylindrique (2) et fixez-le avec un tournevis (non fourni) .

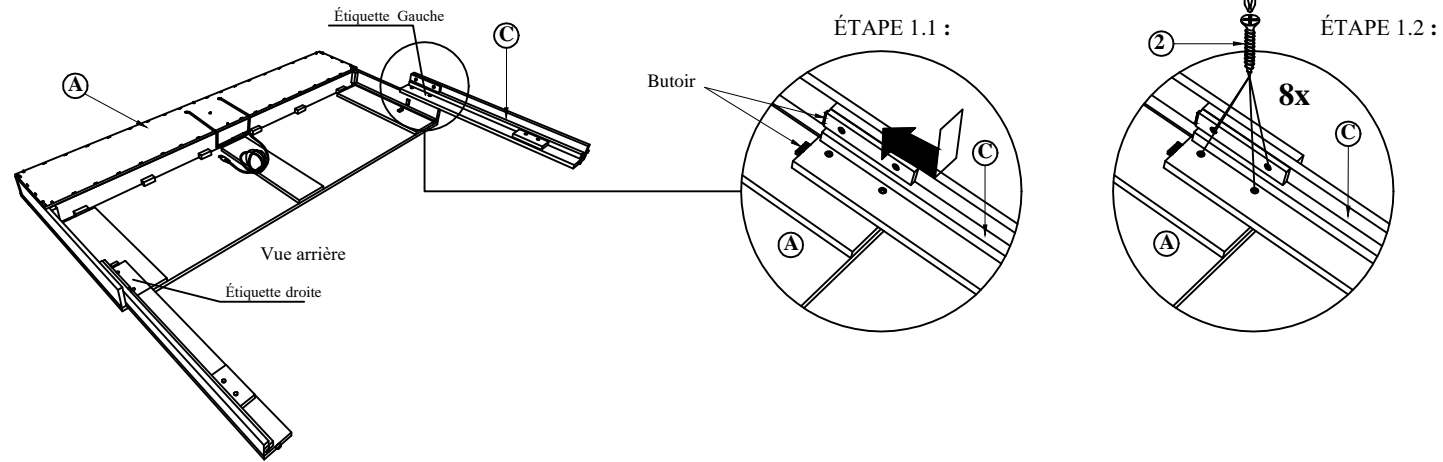

ÉTAPE 2: Vissez les 4 coins à l'aide de la Clé Allen (1)

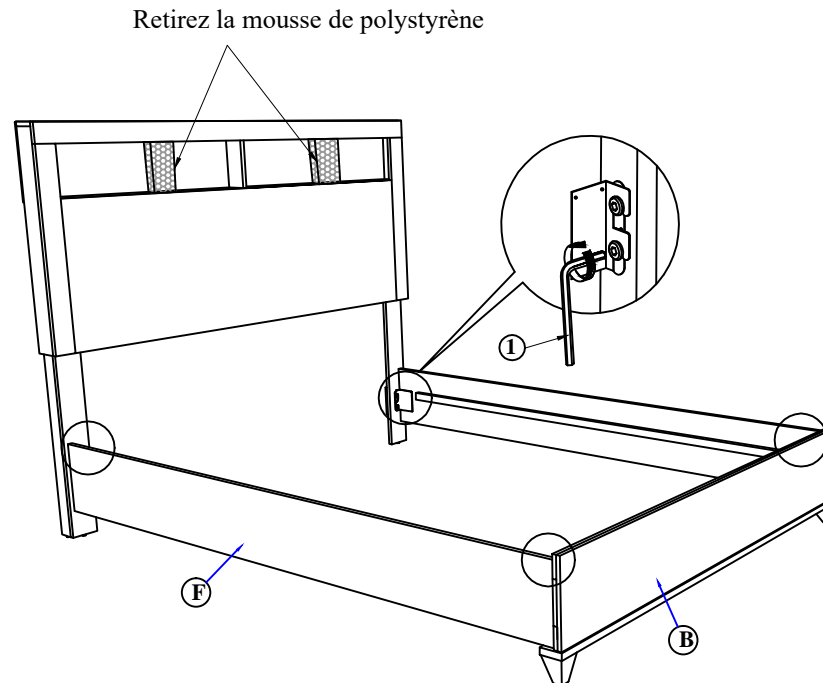

INSTRUCTIONS D'ASSEMBLAGE

ÉTAPE 3: Fixez les pieds (E) au support de lattes de lit (D) comme illustré. Installez les lattes (D) sur le rail latéral (F) et fixez-les à l'aide des vis à tête plate cruciforme (2) selon le schéma. (NOTE : POUR ASSURER LA STABILITÉ PARFAITE DU LIT, SON ASSEMBLAGE DOIT ÊTRE FAIT LÀ OÙ IL SERA UTILISÉ).

ÉTAPE 3.3 :

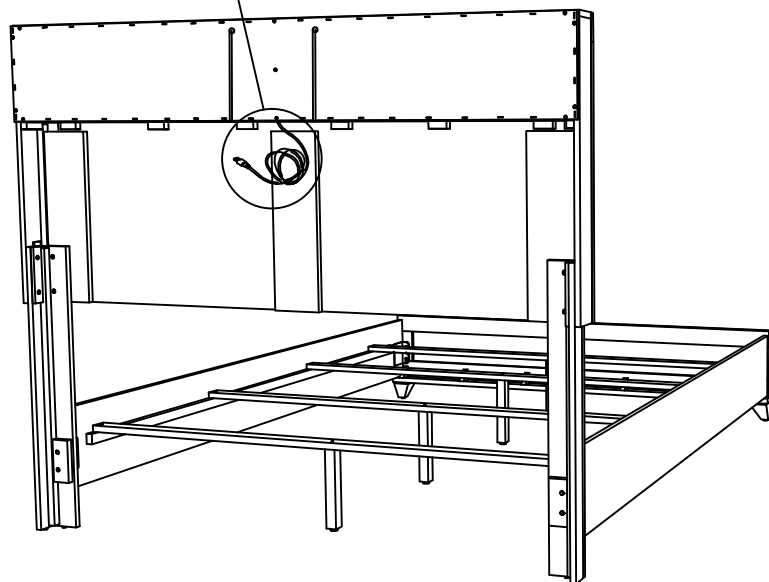
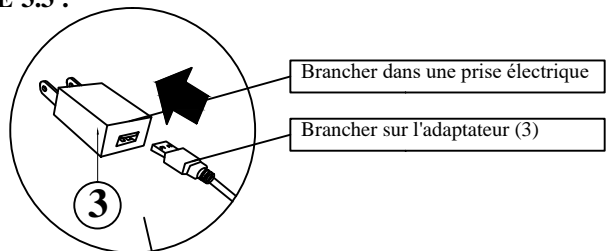

Vue arrière

Bouton de mise en marche

ÉTAPE 3.2 :

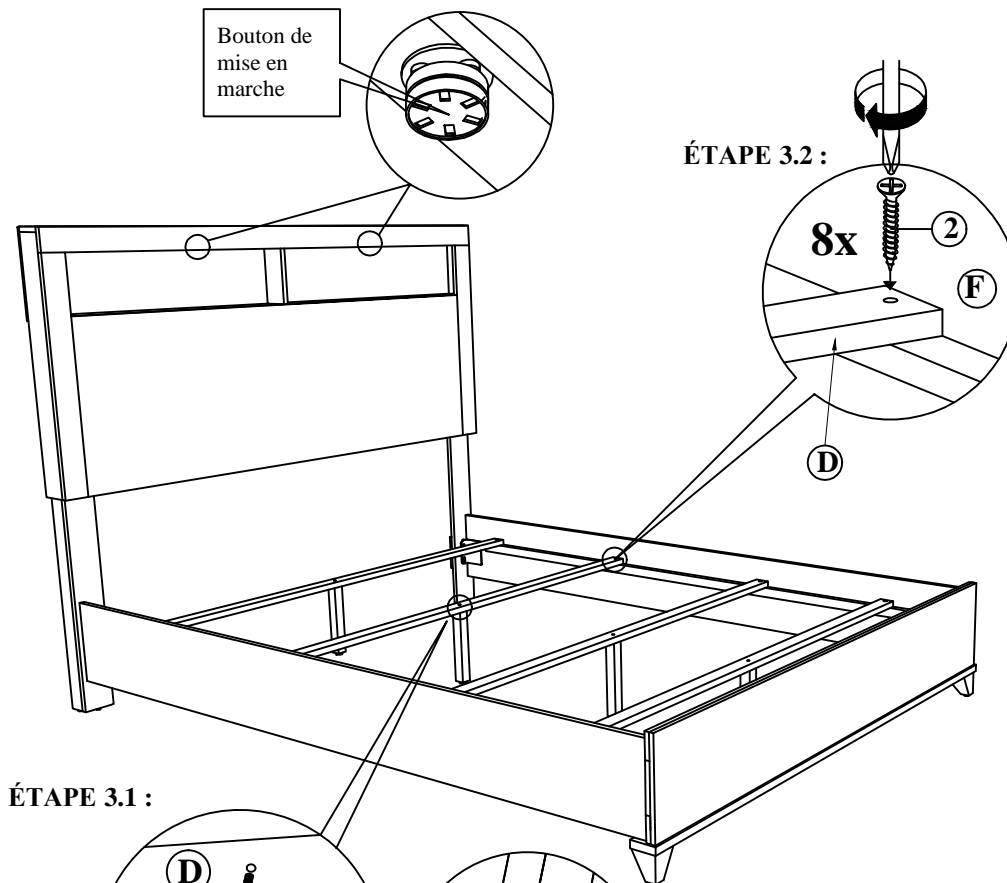

ÉTAPE 3.1 :

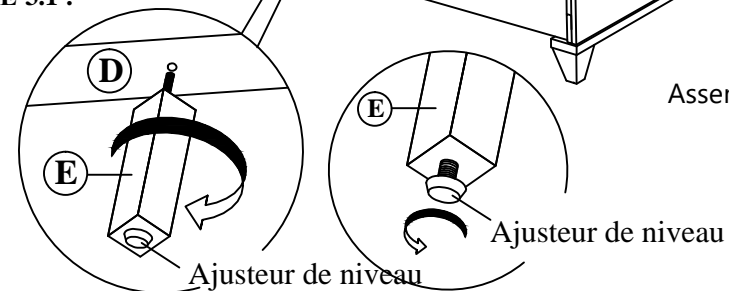

Assemblage complété